



Hewlett Packard
Enterprise

HPE StoreEver 1U Rack-mount Enclosure User Guide

Abstract

This document provides installation instructions and specifications for the HPE StoreEver 1U Rack-mount Enclosures. It is intended for system administrators and technicians experienced with installing tape drives and other hardware into a rack.

Part Number: AE459-96010a
Published: April 2018
Edition: 6

Notices

The information contained herein is subject to change without notice. The only warranties for Hewlett Packard Enterprise products and services are set forth in the express warranty statements accompanying such products and services. Nothing herein should be construed as constituting an additional warranty. Hewlett Packard Enterprise shall not be liable for technical or editorial errors or omissions contained herein.

Confidential computer software. Valid license from Hewlett Packard Enterprise required for possession, use, or copying. Consistent with FAR 12.211 and 12.212, Commercial Computer Software, Computer Software Documentation, and Technical Data for Commercial Items are licensed to the U.S. Government under vendor's standard commercial license.

Links to third-party websites take you outside the Hewlett Packard Enterprise website. Hewlett Packard Enterprise has no control over and is not responsible for information outside the Hewlett Packard Enterprise website.

Acknowledgments

Intel[®], Itanium[®], Pentium[®], Intel Inside[®], and the Intel Inside logo are trademarks of Intel Corporation in the United States and other countries.

Microsoft[®] and Windows[®] are either registered trademarks or trademarks of Microsoft Corporation in the United States and/or other countries.

Adobe[®] and Acrobat[®] are trademarks of Adobe Systems Incorporated.

Java[®] and Oracle[®] are registered trademarks of Oracle and/or its affiliates.

UNIX[®] is a registered trademark of The Open Group.

Contents

Introduction.....	5
Standard Features.....	5
Supported Controllers and HBAs.....	5
Hardware options.....	5
1U rack-mount enclosure components	5
Front panel components.....	5
Rear panel components	6
Supported cables.....	6
Installing drives in the enclosure.....	7
Tools required.....	7
Installing a drive in the first bay.....	7
Installing a drive in the second bay.....	12
Installing the 1U enclosure in a rack.....	18
Rack Safety.....	18
Rack-mounting kit.....	18
Tools Required.....	19
Prerequisites for racks without hole markings.....	19
Installing the component rails.....	19
Installing the rack rails.....	20
Installing the rails in racks with round or square holes.....	20
Installing the rails in racks with 10-32 threaded holes.....	21
Completing the installation.....	23
Service procedures.....	25
Replacing a cable bracket assembly.....	25
Replacing a drive.....	31
Replacing the 1U enclosure chassis.....	36
Moving the SAS repeater board to a replacement enclosure.....	39
Support and other resources.....	41
Accessing Hewlett Packard Enterprise Support.....	41
Accessing updates.....	41
Customer self repair.....	42
Remote support.....	42
Warranty information.....	42
Regulatory information.....	43
Documentation feedback.....	43
Legacy cable connections.....	44
Parallel SCSI cable connections.....	44
LTO 1, LTO 2, LTO 3, and LTO 4 cable connections.....	44

Appendix: Specifications..... 46

Electrostatic discharge (ESD)..... 48

 Preventing Electrostatic Discharge..... 48

 Grounding methods to prevent electrostatic discharge..... 48

Introduction

The HPE StoreEver 1U Rack-mount Enclosure is a rack-mountable storage system capable of holding up to two half-height 5.25 inch LTO tape drives or RDX disk drives. It is compatible with most standard 19 inch racks.

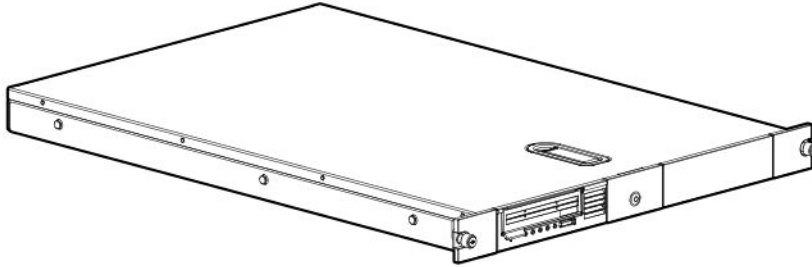

Figure 1: 1U Rack-mount Enclosure

Standard Features

Standard features of the 1U rack-mount enclosure:

- Supports one or two 5.25 inch LTO half-height tape drives or RDX disk drives
- Installation in standard 19 inch racks with round, square, or threaded holes

Supported Controllers and HBAs

For up-to-date SAS HBA compatibility information, review the compatibility matrix on the Enterprise Backup Solutions website at: <http://www.hpe.com/storage/DAPRcompatibility>.

For up-to-date SAS HBA compatibility information, refer to the manufacturer website.

Hardware options

For a list of currently supported hardware options, such as LTO tape and RDX drives, see the HPE website at: <http://www.hpe.com/storage/tape>.

1U rack-mount enclosure components

Front panel components

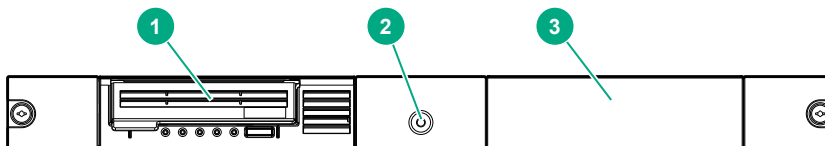

Figure 2: 1U rack-mount enclosure front panel components

1. Drive
2. Power switch/LED
3. Expansion drive bay with drive blank installed

For proper cooling, a tape drive, RDX drive, or drive blank must always be installed in each drive bay.

Rear panel components

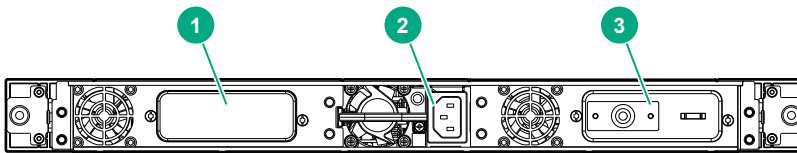

Figure 3: 1U rack-mount enclosure rear panel components

1. Cover Plate, where the cable for the second drive will exit the chassis
2. AC Power Connector
3. External SAS or USB bracket assembly shown exiting the chassis

For effective drive cooling during operation, a cover plate or HPE supported cable bracket assembly must always be installed in both locations.

Supported cables

Each drive installed in the enclosure must have an HPE supported cable assembly with the necessary connectors for the drive and HBA. For a list of supported HPE cables, see the product Quick Specs.

Installing drives in the enclosure

Tools required

A 3/16" (5mm) flat-blade screwdriver or T-15 Torx driver may be required to install a drive in the 1U rack-mount enclosure.

Installing a drive in the first bay

⚠ CAUTION:

To avoid damaging the equipment due to electrostatic discharge, review and practice the procedures in **Electrostatic Discharge** before handling the drives.

Procedure

1. Remove the top access panel as shown.

Unlock the latch if necessary.

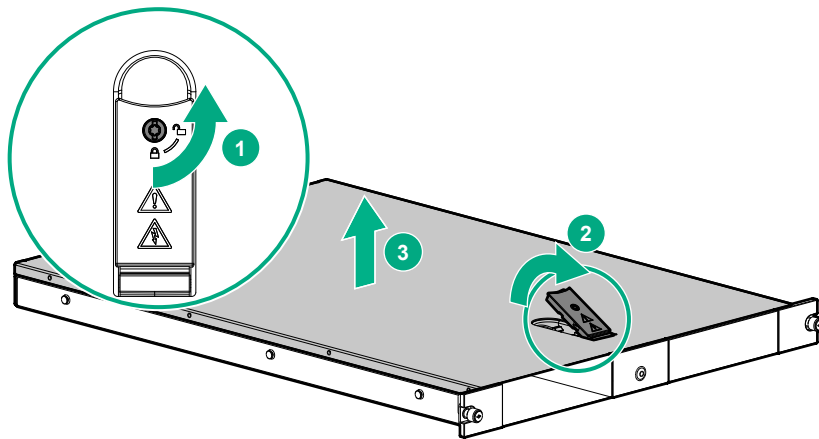

Figure 4: Removing the access panel

2. Remove the drive mounting brackets from the left bay.
The drive mounting brackets are shipped in the left drive bay secured with tape.
 - a. Pull the spring-loaded button on the right mounting rail up.
 - b. Slide the assembly forward and then lift.
 - c. Remove the tape retaining the left drive mounting bracket.
 - d. Slide the left mounting bracket forward and then lift.
3. Install the mounting brackets to the sides of the drive.
If installing a tape drive, always use the 4 mm M3 screws provided with the drive.

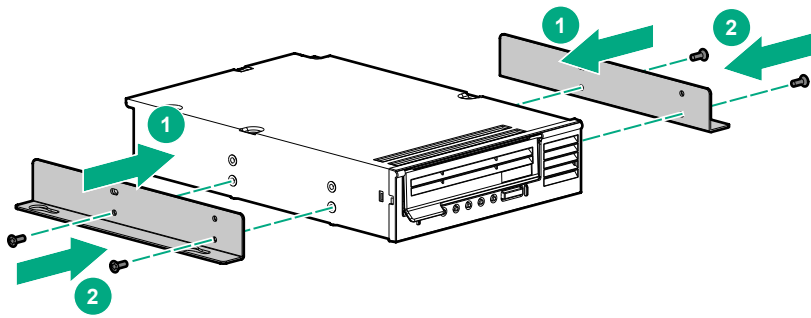

Figure 5: Installing the mounting brackets on the drive

⚠ CAUTION:

When installing an LTO half-height tape drive, it is important that you use the 4 mm M3 screws provided with the drive. If the screws are too long, they may damage the mechanism and void the warranty. Do not overtighten the screws.

4. Install the drive in the enclosure:
 - a. Position the mounting bracket keyhole slots over the mounting posts and then lower the drive.
 - b. Slide the drive toward the back of the enclosure.
 - c. The spring-loaded button will automatically snap into place.

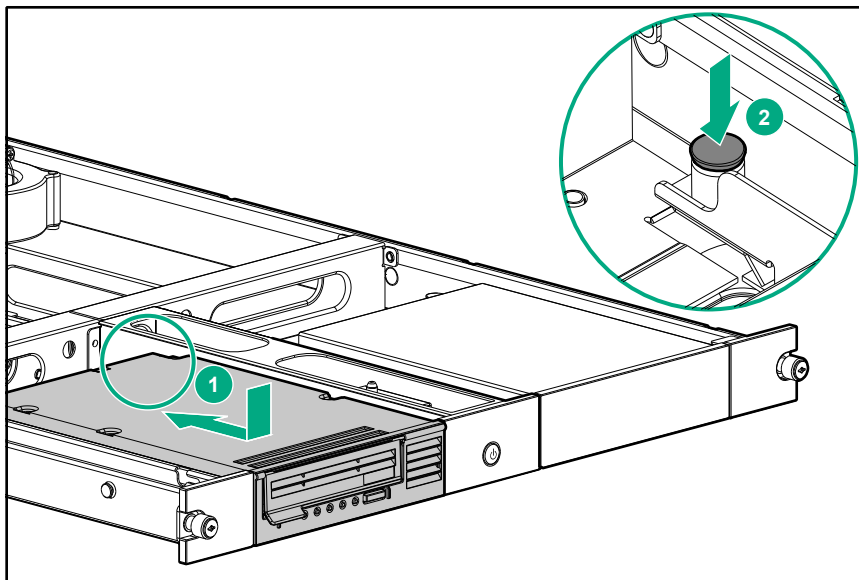

Figure 6: Slide the drive into the enclosure

5. Install the cable bracket assembly in the enclosure.
 - a. Thread the host end of the cable through the opening in the rear panel.
 - b. Thread the drive end of the cable through the enclosure interior.
 - c. From inside the enclosure, insert the bracket assembly in the opening. Use two screws to secure the bracket assembly to the chassis.

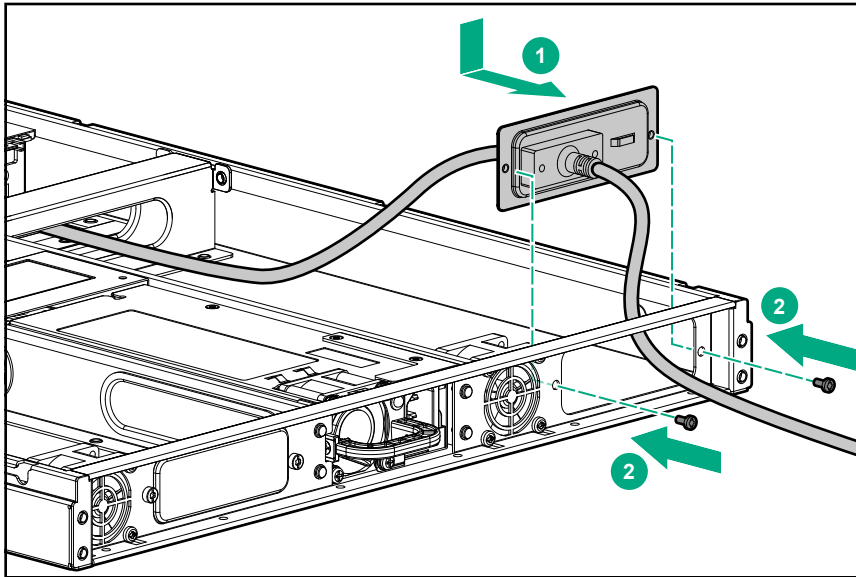

Figure 7: Installing the cable with bracket assembly

6. Attach the data and power cables to the rear of the drive.

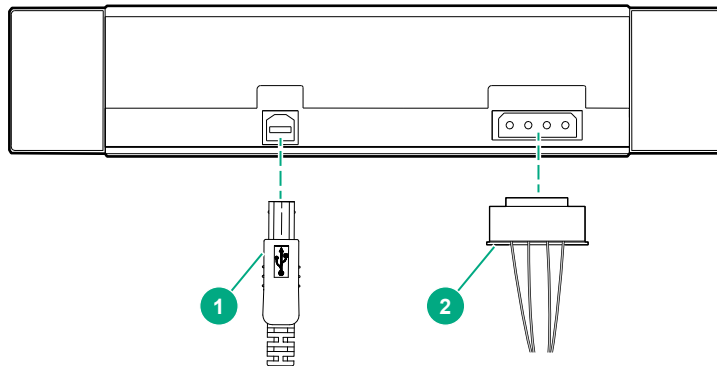

Figure 8: RDX drive cable connections

1	USB cable
2	Power cable

NOTE:

The drive side of the HPE-supported USB 3.0 cable assembly plug plastic housing is blue and will not connect to USB 2.0 devices.

The HPE-supported USB 2.0 cable assembly will connect to a USB 3.0 device. Using a USB 2.0 cable assembly with a USB 3.0 device will result in significantly slower data transfer.

Use the appropriate cable for your device.

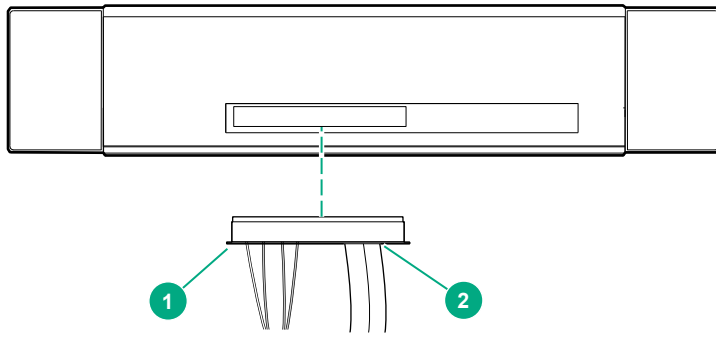

Figure 9: LTO 5, LTO 6, LTO 7, and LTO 8 cable connection

1	Power side of cable
2	Data side of cable

For other supported drives, see [LTO 1, LTO 2, LTO 3, and LTO 4 cable connections](#) or [Parallel SCSI cable connections](#).

NOTE:

Route the excess cable neatly and secure with the clips provided in the enclosure.

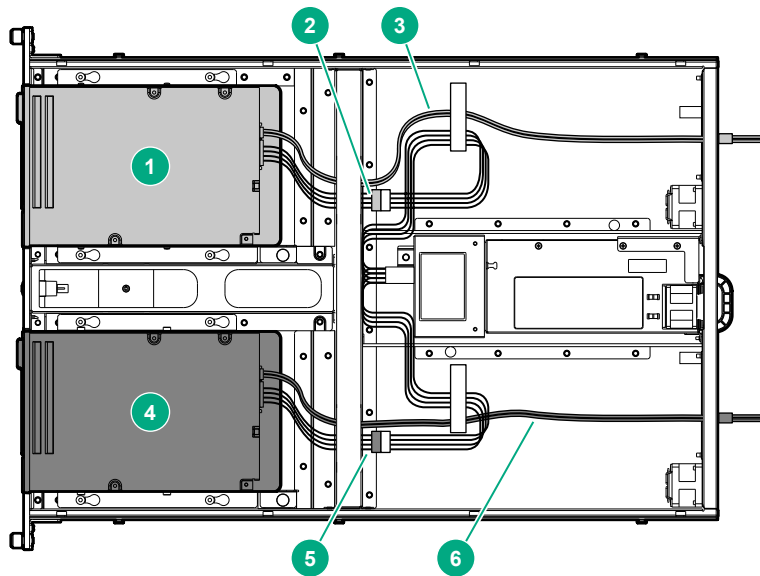

Figure 10: Internal cabling for two SAS drives

- | | |
|---------------------------------|---------------------------------|
| 1. Drive 1 | 2. Power cable used for drive 1 |
| 3. SAS bus 1 cable | 4. Drive 2 |
| 5. Power cable used for drive 2 | 6. SAS bus 2 cable |

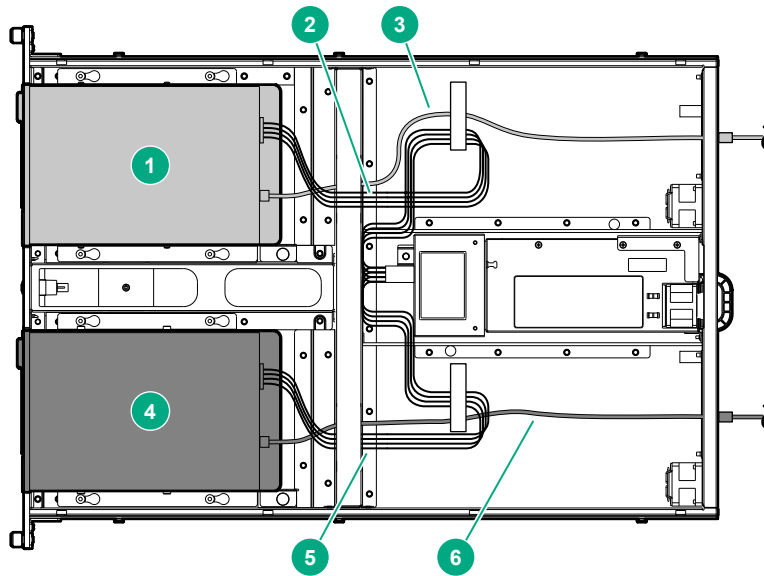

Figure 11: Internal cabling for two RDX drives

- | | |
|---------------------------------|---------------------------------|
| 1. Drive 1 | 2. Power cable used for drive 1 |
| 3. USB cable for drive 1 | 4. Drive 2 |
| 5. Power cable used for drive 2 | 6. USB cable for drive 2 |
7. If you are not installing a second drive, replace the top access panel as shown.
If needed, lock the latch using a T15 Torx screwdriver.

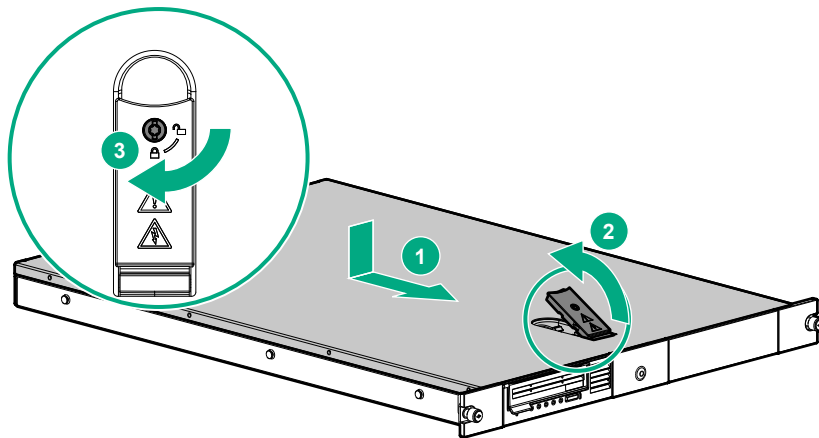

Figure 12: Replacing the access panel

Installing a drive in the second bay

⚠ CAUTION:

To avoid damaging the equipment due to electrostatic discharge, be sure to review and practice the procedures in **Electrostatic Discharge** before handling the drives.

Procedure

1. Remove the top access panel if necessary.

Unlock the latch if necessary.

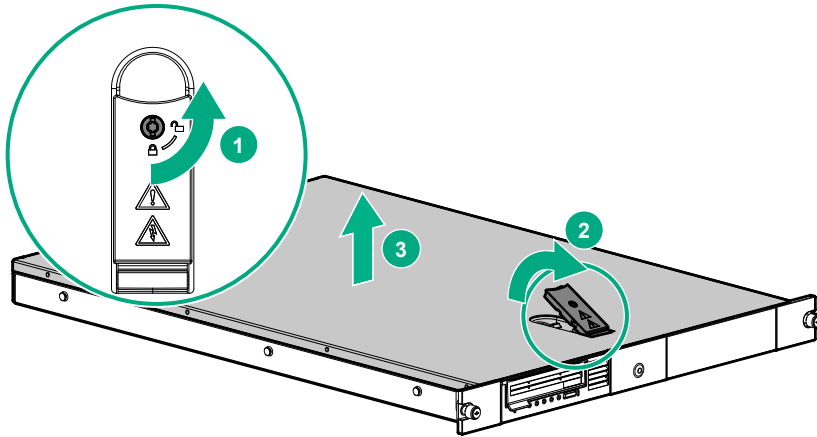

Figure 13: Removing the access panel

2. Remove the drive blank.

- a. Pull the spring-loaded button on the right mounting rail up.
- b. Slide the assembly forward and then lift.

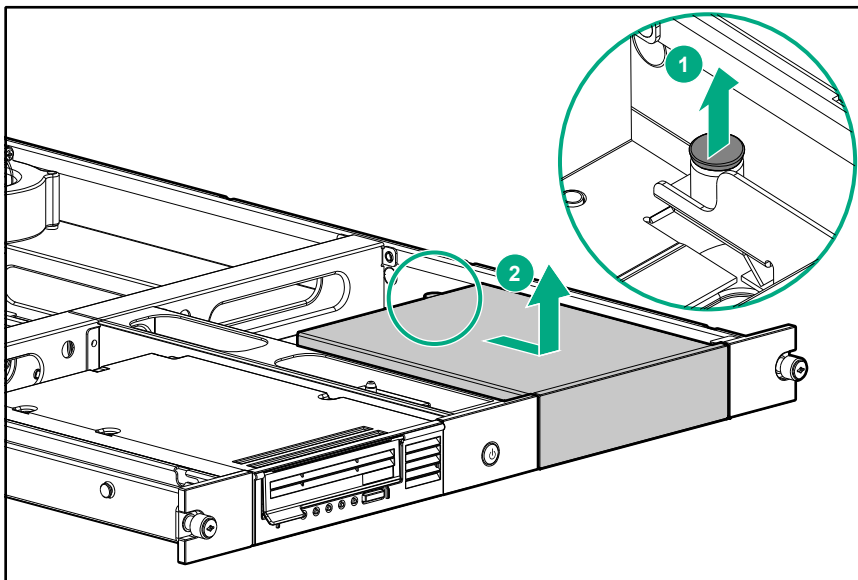

Figure 14: Removing the drive blank

3. Remove the mounting brackets from the drive blank.

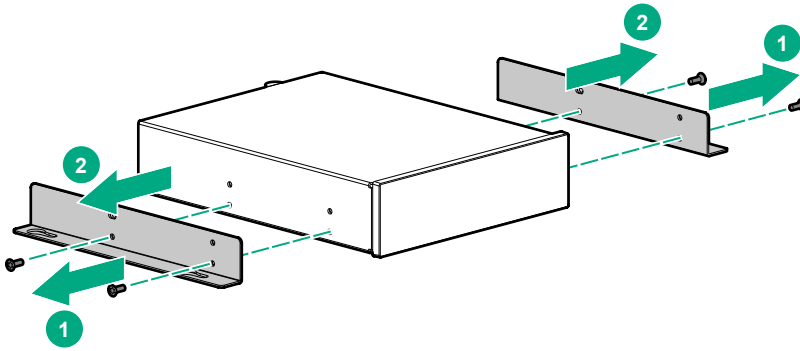

Figure 15: Removing the drive mounting brackets from the blank

4. Install the mounting brackets to the sides of the drive.
If installing a tape drive, always use the 4 mm M3 screws provided with the drive.

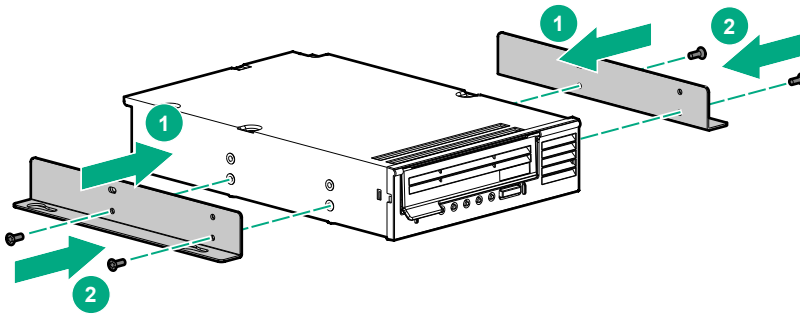

Figure 16: Installing the drive mounting brackets on the drive

⚠ CAUTION:

When installing an LTO half-height tape drive, it is important that you use the 4 mm M3 screws provided with the drive. If the screws are too long, they may damage the mechanism and void the warranty. Do not overtighten the screws.

5. Install the drive in the enclosure.
 - a. Position the mounting bracket keyhole slots over the mounting posts and then lower the drive.
 - b. Slide the drive toward the back of the enclosure.

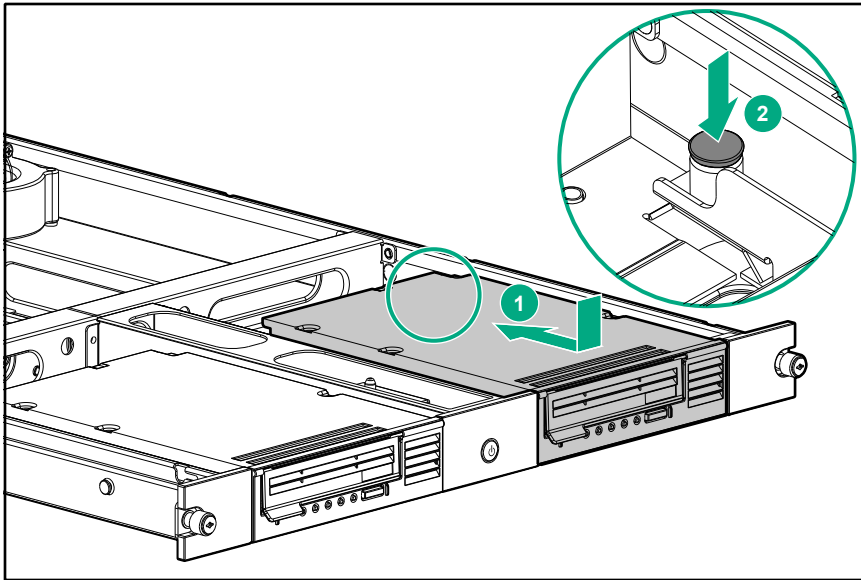

Figure 17: Installing the drive

The spring-loaded button will automatically snap into place.

6. Install the cable bracket assembly in the enclosure.
 - a. Thread the host end of the cable through the opening in the rear panel.
 - b. Thread the drive end of the cable through the enclosure interior.
 - c. From inside the enclosure, insert the bracket assembly in the opening. Use two screws to secure the bracket assembly to the chassis.

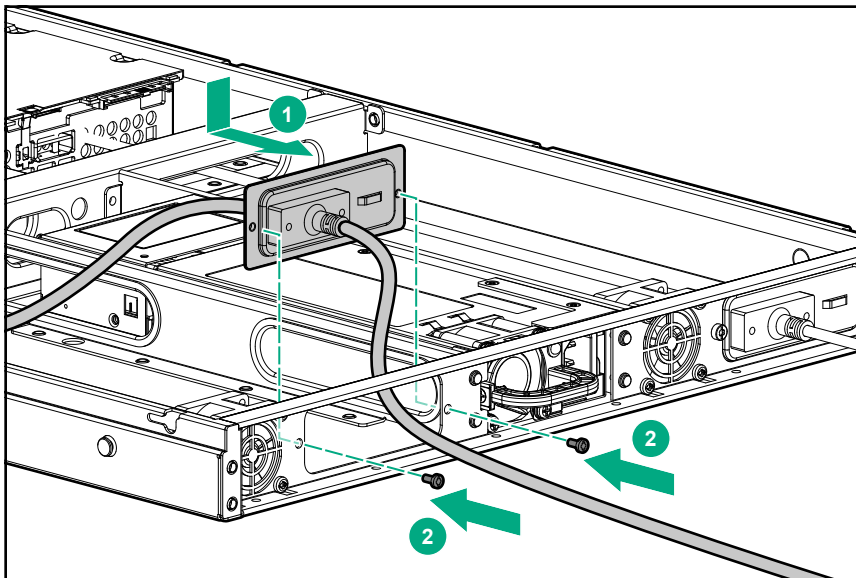

Figure 18: Installing the cable with bracket assembly

7. Attach the data and power cables to the rear of the drive.

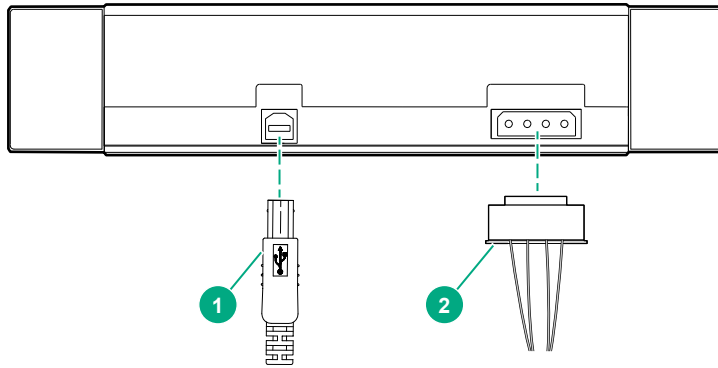

Figure 19: RDX drive cable connections

1	USB cable
2	Power cable

NOTE:

The drive side of the HPE-supported USB 3.0 cable assembly plug plastic housing is blue and will not connect to USB 2.0 devices.

The HPE-supported USB 2.0 cable assembly will connect to a USB 3.0 device. Using a USB 2.0 cable assembly with a USB 3.0 device will result in significantly slower data transfer.

Use the appropriate cable for your device.

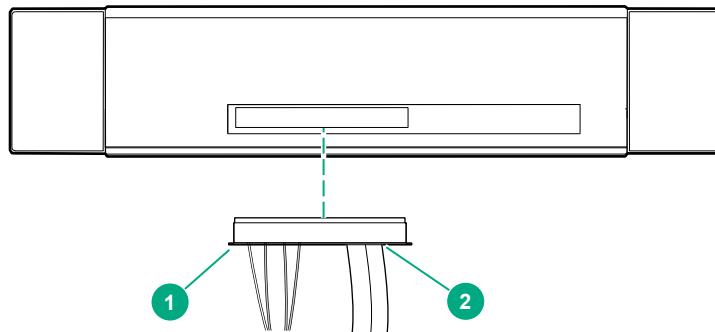

Figure 20: LTO 5, LTO 6, LTO 7, and LTO 8 cable connection

1	Power side of cable
2	Data side of cable

For other supported drives, see [LTO 1, LTO 2, LTO 3, and LTO 4 cable connections](#) or [Parallel SCSI cable connections](#).

NOTE:

Route the excess cable neatly and secure with the clips provided in the enclosure.

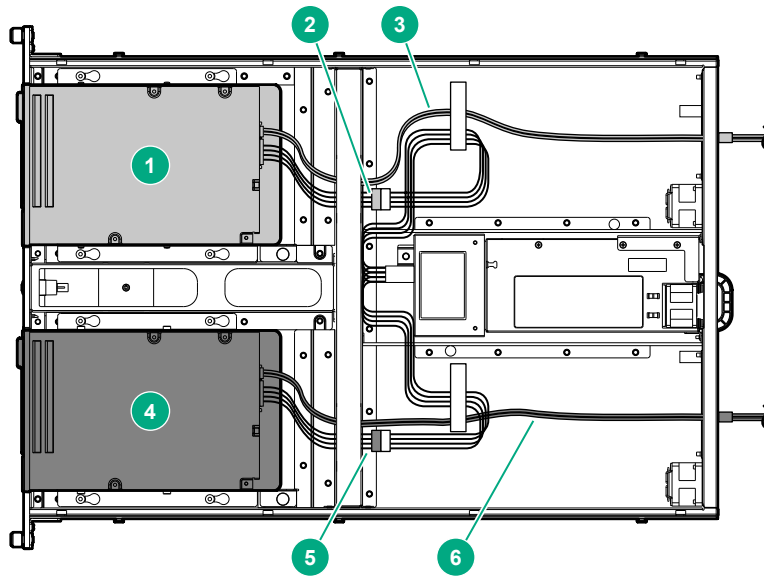

Figure 21: Internal cabling for two SAS drives

- | | |
|---------------------------------|---------------------------------|
| 1. Drive 1 | 2. Power cable used for drive 1 |
| 3. SAS bus 1 cable | 4. Drive 2 |
| 5. Power cable used for drive 2 | 6. SAS bus 2 cable |

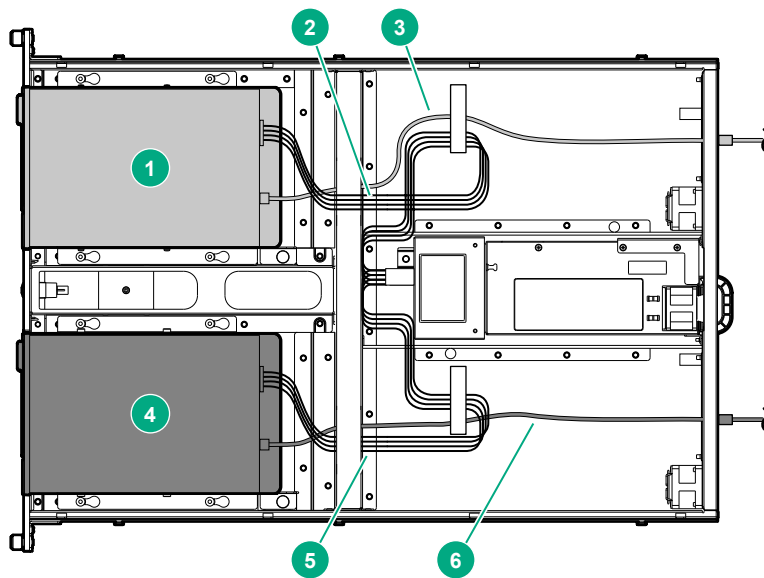

Figure 22: Internal cabling for two RDX drives

1. Drive 1
 2. Power cable used for drive 1
 3. USB cable for drive 1
 4. Drive 2
 5. Power cable used for drive 2
 6. USB cable for drive 2
8. Replace the top access panel.
If needed, lock the latch using a T15 Torx driver.

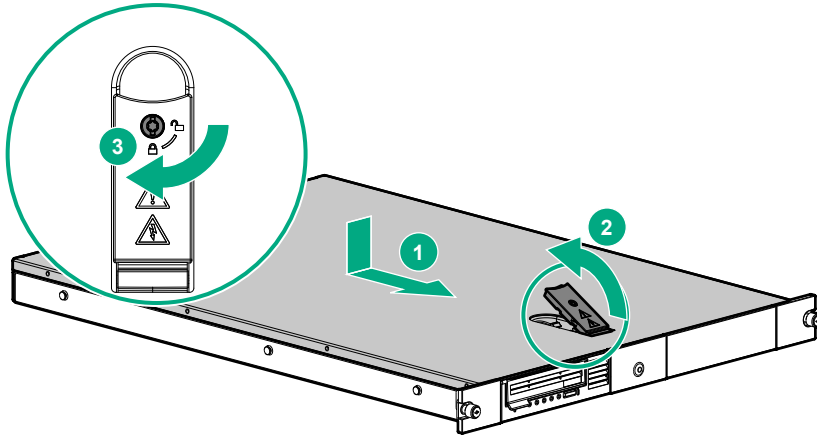

Figure 23: Replacing the access panel

Installing the 1U enclosure in a rack

Rack Safety



WARNING:

To reduce the risk of personal injury or equipment damage, be sure that:

- The rack leveling jacks are extended to the floor
 - The full weight of the rack rests on the leveling jacks
 - The stabilizing feet are attached to the rack
 - The racks are coupled in multiple rack installations
 - Only one component is extended at a time. A rack may become unstable if more than one component is extended for any reason.
-

When installing the enclosure in a rack:

- Start at the bottom of the rack, or at the top of a previously mounted component, and work upward
- For increased rack stability, install the heaviest components at the bottom and lighter ones toward the top of the rack
- Make sure that the rack-mounting rails are level from front to back and side to side

Rack-mounting kit

The rack-mounting kit supplied with the 1U rack-mount enclosure can be used to install the enclosure in most racks. The rails can be installed in racks with round, square, or threaded holes in the vertical mounting columns. The rails fit racks with 23 - 34 inches (58 - 86 cm) separation between the front and rear vertical mounting columns. The rails are identical and may be mounted on either the left or the right side.

- | | |
|------------------------|--------------------------|
| 1. Outer rack rails | 2. Inner component rails |
| 3. Cable support clips | 4. Fasteners |

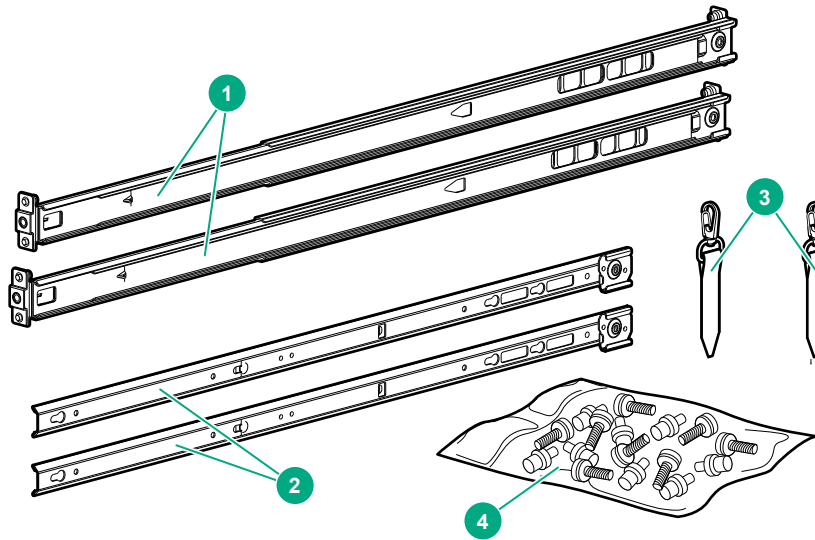

Figure 24: Rack-mounting kit components

Tools Required

If you are installing the 1U rack-mount enclosure in a rack with unmarked holes in the vertical mounting columns the following items will make the rack installation easier:

- Pencil
- Tape measure

If you are installing the 1U rack-mount enclosure in a rack with threaded holes in the vertical mounting columns you will need a 3/16" (5mm) flat-blade screwdriver.

Prerequisites for racks without hole markings

For proper operation, the enclosure must be level when mounted in the rack. If the rack does not have hole markings in the vertical mounting columns, identify and mark the correct mounting holes in the rack before installing the rails.

⚠ CAUTION:

It is important to install rack components level. To ensure that the 1U rack-mount enclosure is installed correctly, measure the height of the correct mounting holes in the front and rear vertical mounting columns.

Installing the component rails

The inner component rails attach to the 1U rack-mount enclosure.

Procedure

1. Align the slotted holes on the inner component rails with the three pins on the sides of the enclosure.
2. Slide the component rails toward the rear of the enclosure until they lock into place.

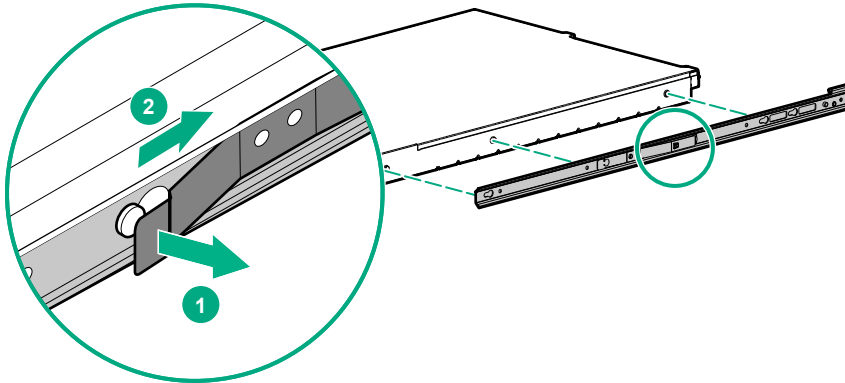

Figure 25: Installing the component rails

⚠ **IMPORTANT:**

If you are returning the 1U rack-mount enclosure for service, remove the inner component rail and reinstall it on the replacement chassis.

To remove the component rail, pull out the spring-loaded tab on the side of the rail and slide it forward.

Installing the rack rails

Use the installation procedure for your rack.

- Racks with round or square holes
- Racks with 10-32 threaded holes

Installing the rails in racks with round or square holes

NOTE:

The ends of the rack rails are marked FRONT and REAR for proper orientation.

Procedure

1. Insert the pins in the front mounting plate of the outer rack rails into the previously marked holes in the front vertical mounting columns of the rack. The rack rails will lock securely into place.

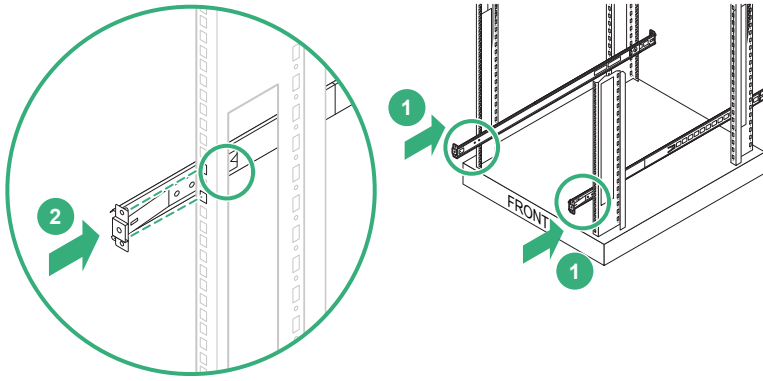

Figure 26: Inserting the pins

NOTE:

To remove the rail for repositioning, push the spring-loaded tab on the outside of the rack rail and slide it forward.

2. Extend the rack rails past the rear vertical mounting column. Insert the pins in the mounting bracket into the previously marked holes in the rack. The rack rails will lock securely into place when the ends of the rails are pushed forward.

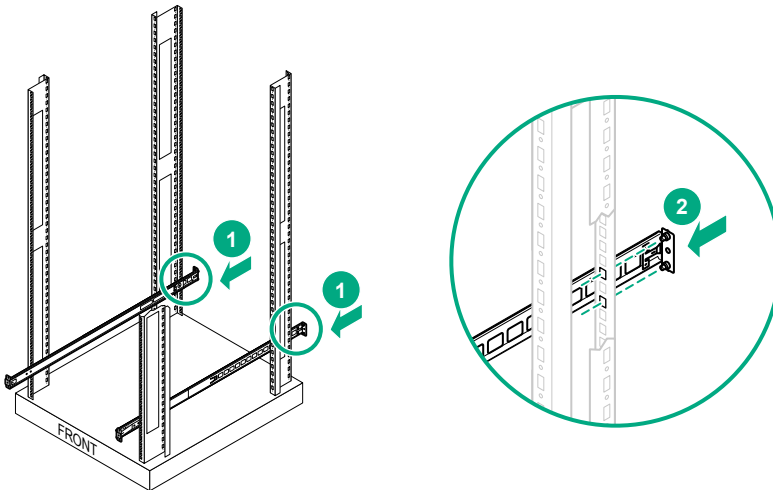

Figure 27: Locking the rack rails

NOTE:

To remove the rail for repositioning, push the spring-loaded tab on the outside of the rack rail and slide rearward.

3. Rail installation in a rack is complete. Continue with **Completing the Installation**.

Installing the rails in racks with 10-32 threaded holes

Prerequisites

8 10-32 x 0.375 screws

Procedure

1. Remove the pins and threaded plates from both ends of each outer rack rail. These pieces will not be used.

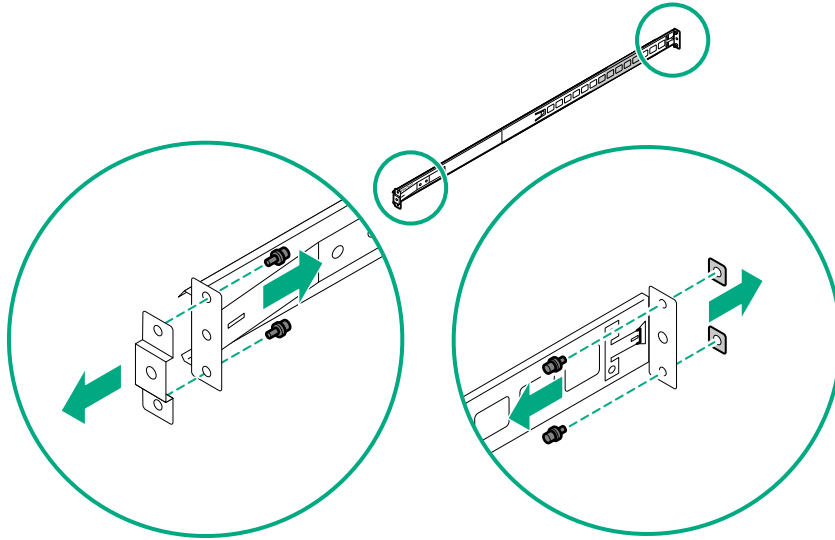

Figure 28: Removing the pins and threaded plates

NOTE:

The ends of the rack rails are marked FRONT and REAR for proper orientation.

2. Extend the rack rails past the front vertical mounting columns. Attach the front mounting plate of each outer rail to the rack using four 10-32 screws in the previously marked holes.

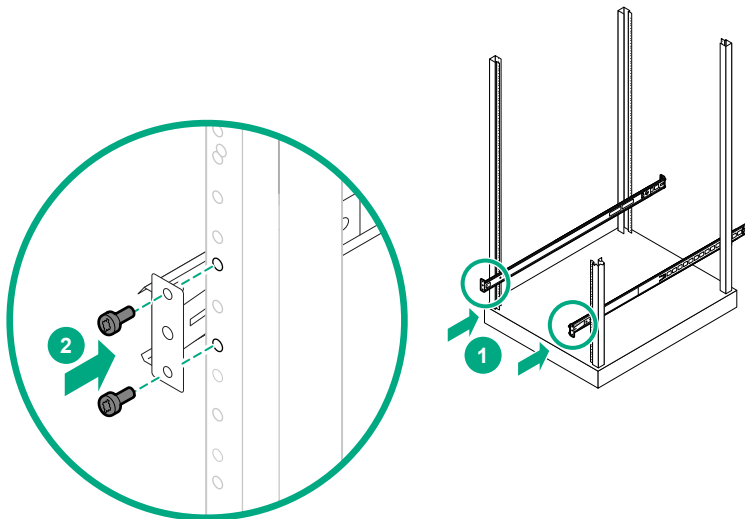

Figure 29: Attaching the front mounting plate

3. Extend the rack rails past the rear vertical mounting columns. Attach the back mounting plate of each outer rail to the rack using four 10-32 screws in the previously marked holes.

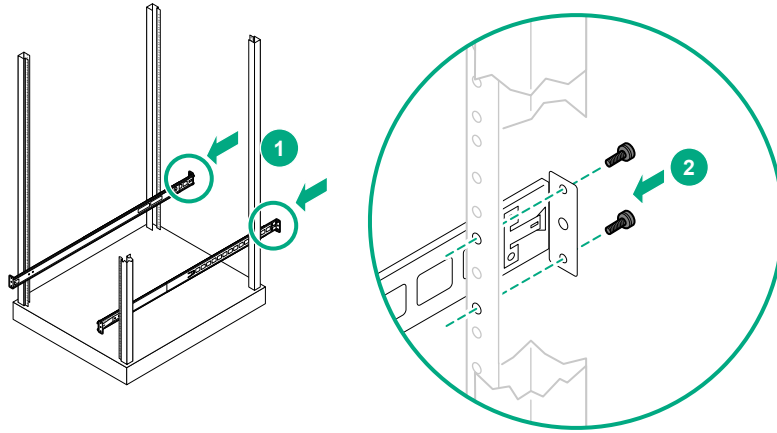

Figure 30: Attaching the back mounting plate

Completing the installation

Prerequisites

Ensure all rack safety precautions stated in **Rack Safety** on page 18 have been implemented.

Procedure

1. Extend the left and right rack rails from the front of the rack.
2. Align the rear of the component rails on the enclosure with the front ends of the rack rails, then slide the unit fully into the rack.

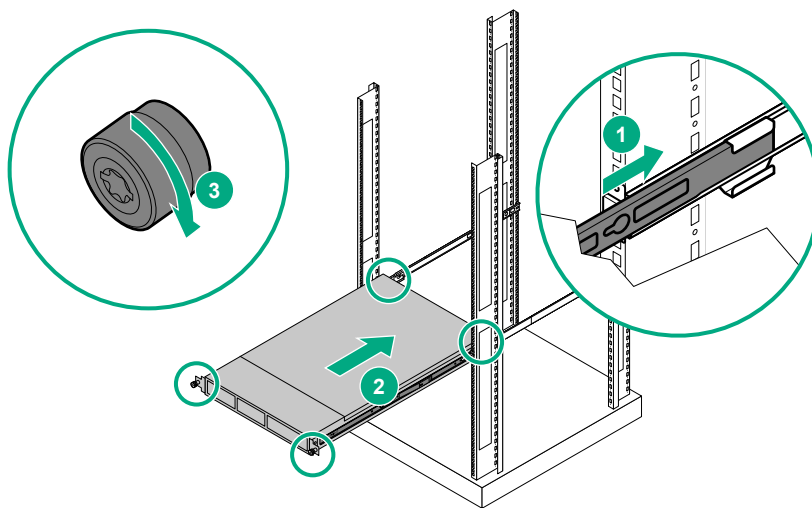

Figure 31: Sliding the unit into the rack

⚠ CAUTION:

Be sure to keep the enclosure parallel to the floor when sliding the component rails into the rack rails. Tilting the enclosure up or down could damage the rails.

3. Tighten the front panel thumbscrews.
4. Retract the stabilizing feet of the rack.
5. Plug the data cables from the rack-mount enclosure into the data connectors on the server.
6. Plug the AC power cord into the rear of the rack-mount enclosure. Plug the other end of the AC power cord into a grounded (earthed) electrical outlet that is easily accessible at all times.
7. Install the cable support clips at the back of the rack rails on one or both sides of the enclosure.

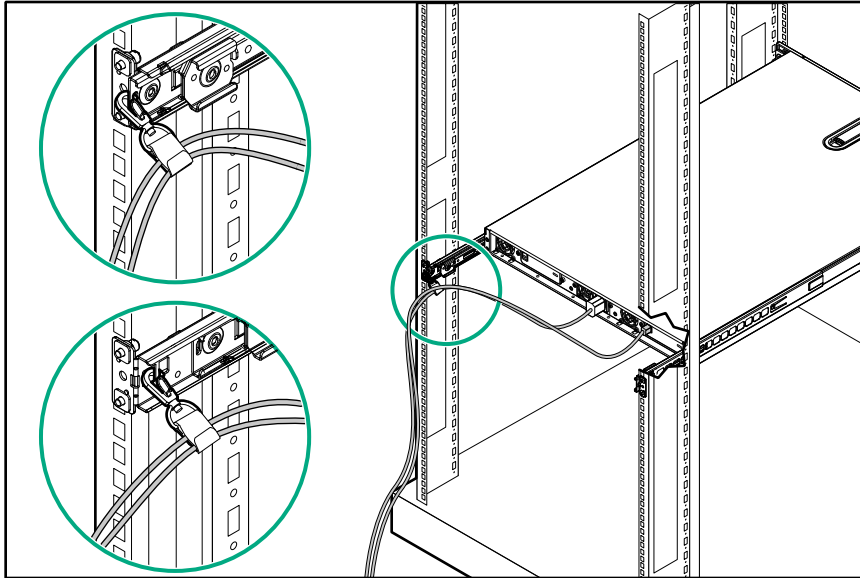

Figure 32: Installing the cable support clips

8. Power on the enclosure with the front panel power button.
 - a. Press the power button on the front panel of the enclosure.
 - b. Verify that the drives pass the self test.
 - c. Verify that the host server recognizes the drives.
 - d. Verify that the backup software application recognizes the drives.
 - e. Verify that the drives have the latest firmware installed. Update the firmware if necessary.

Service procedures

Replacing a cable bracket assembly

⚠ CAUTION:

To avoid damaging the equipment due to electrostatic discharge, be sure to review and practice the procedures in **Electrostatic Discharge** before handling the drives.

Prerequisites

Ensure all rack safety precautions stated in **Rack Safety** on page 18 have been implemented.

Procedure

1. Verify that all host processes are idle. Power down the rack-mount enclosure.
2. Disconnect the power cord from the rear of the enclosure. Disconnect the data cables from the host.
3. Remove the rack-mount enclosure with the failed cable bracket assembly from the rack. Place it on a static-safe work surface.
 - a. Loosen the captive thumbscrews.
 - b. Press the retaining clips on each side of the enclosure.
 - c. Slide the enclosure forward and out of the rack.

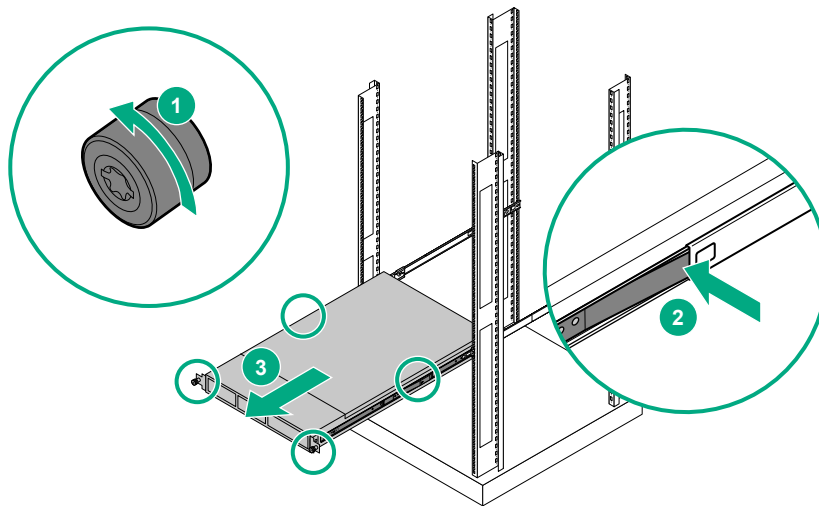

Figure 33: Removing the enclosure from the rack

4. Remove the top access panel.
Unlock the latch if necessary.

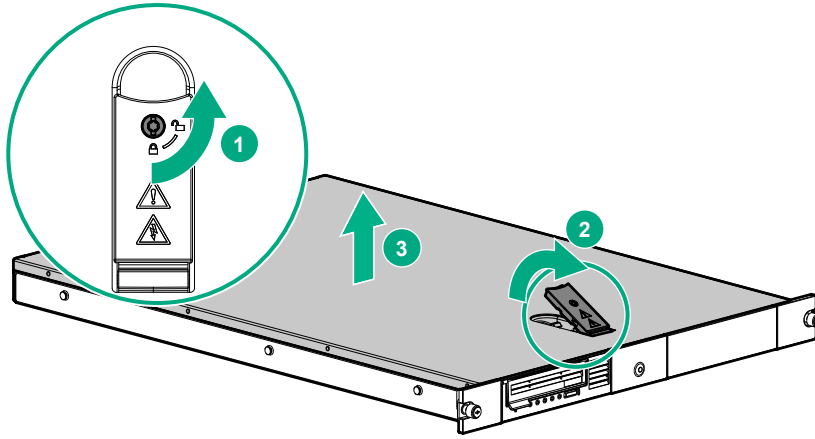

Figure 34: Removing the access panel

5. Disconnect the cables from the back of the drive.
6. Remove the cable bracket assembly.

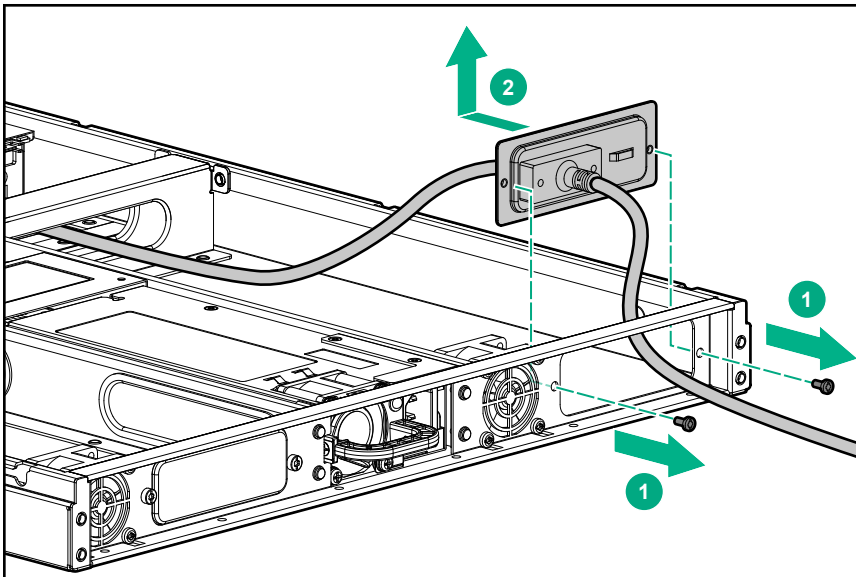

Figure 35: Removing the cable bracket assembly

7. Replace the cable bracket assembly.
 - a. Thread the host end of the cable through the opening in the rear panel.
 - b. Thread the drive end of the cable through the enclosure interior.
 - c. From inside the enclosure, insert the bracket assembly in the opening. Use two screws to secure the bracket assembly to the chassis.

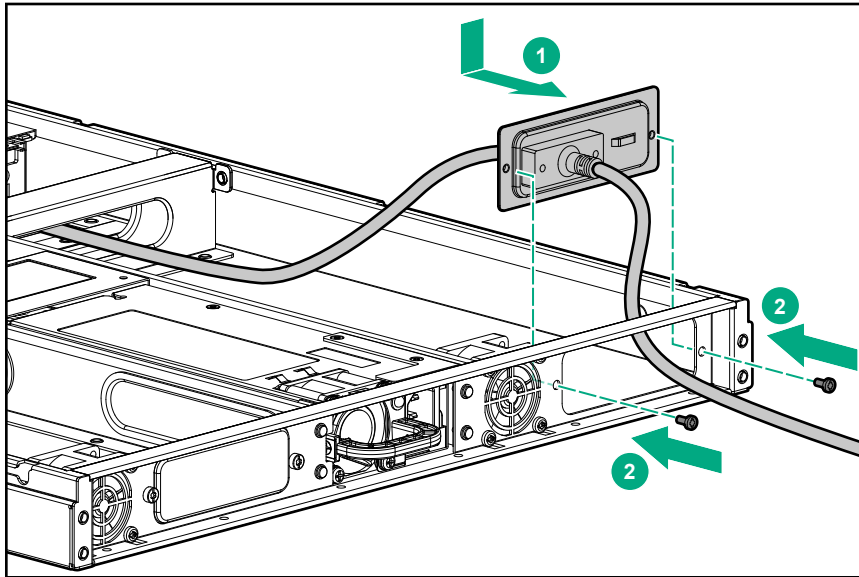

Figure 36: Installing the cable with bracket assembly

8. Reattach the data and power cables to the rear of the drive.

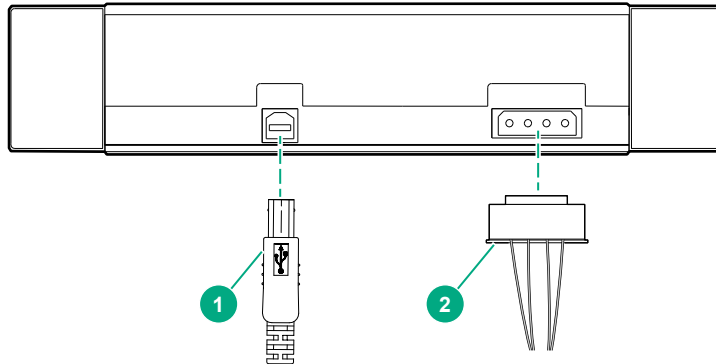

Figure 37: RDX drive cable connections

1	USB cable
2	Power cable

NOTE:

The drive side of the HPE-supported USB 3.0 cable assembly plug plastic housing is blue and will not connect to USB 2.0 devices.

The HPE-supported USB 2.0 cable assembly will connect to a USB 3.0 device. Using a USB 2.0 cable assembly with a USB 3.0 device will result in much slower data transfer.

Use the appropriate cable for your device.

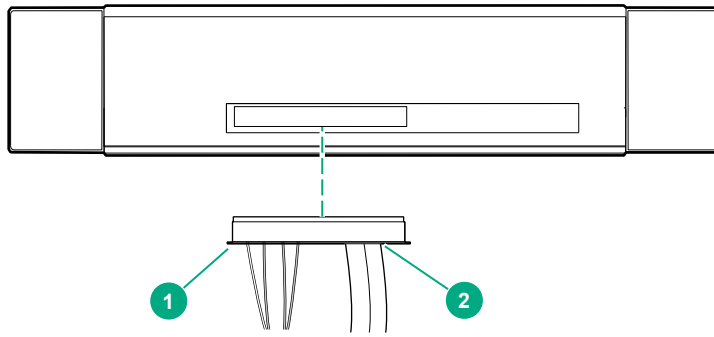

Figure 38: LTO 5, LTO 6, LTO 7, and LTO 8 cable connection

1	Power side of cable
2	Data side of cable

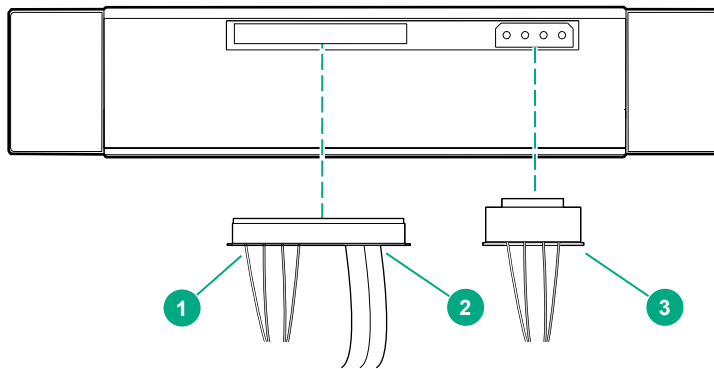

Figure 39: LTO 1, LTO 2, LTO 3, and LTO 4 cable connection

1	Power side of SAS cable - not used for LTO 1, LTO 2, LTO 3, and LTO 4 drives
2	Data side of SAS cable
3	Power cable

NOTE:

The power connector attached to the SAS cable will NOT be used in this case.

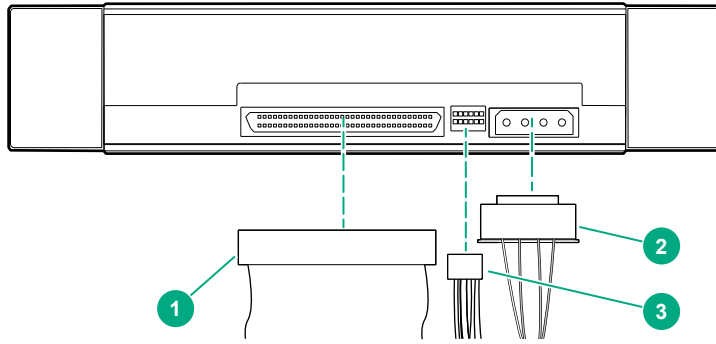

Figure 40: Parallel SCSI cable connection

1	Parallel SCSI cable
2	Power cable
3	SCSI ID switch



CAUTION:

To prevent possible data errors, when there is only one device on a SCSI bus, connect it to the SCSI port closest to the terminator.

NOTE:

Route the excess cable neatly and secure with the clips provided in the enclosure.

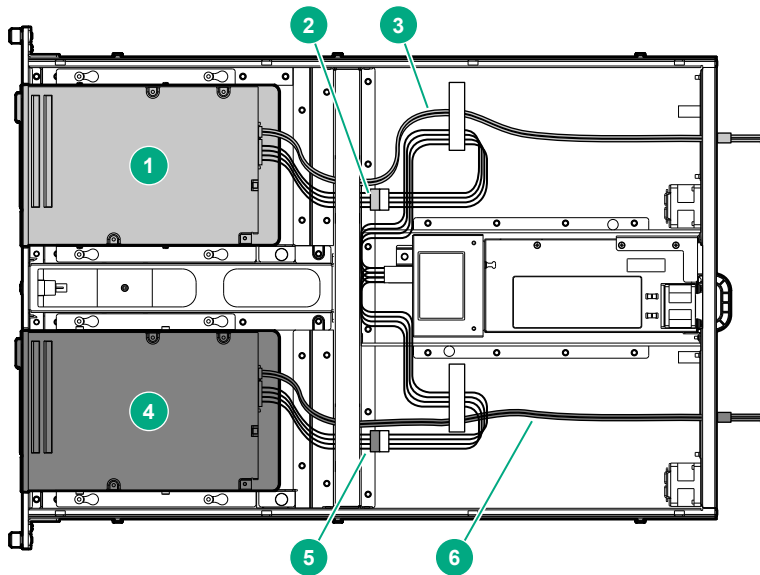

Figure 41: Internal cabling for two SAS drives

- | | |
|---------------------------------|---------------------------------|
| 1. Drive 1 | 2. Power cable used for drive 1 |
| 3. SAS bus 1 cable | 4. Drive 2 |
| 5. Power cable used for drive 2 | 6. SAS bus 2 cable |

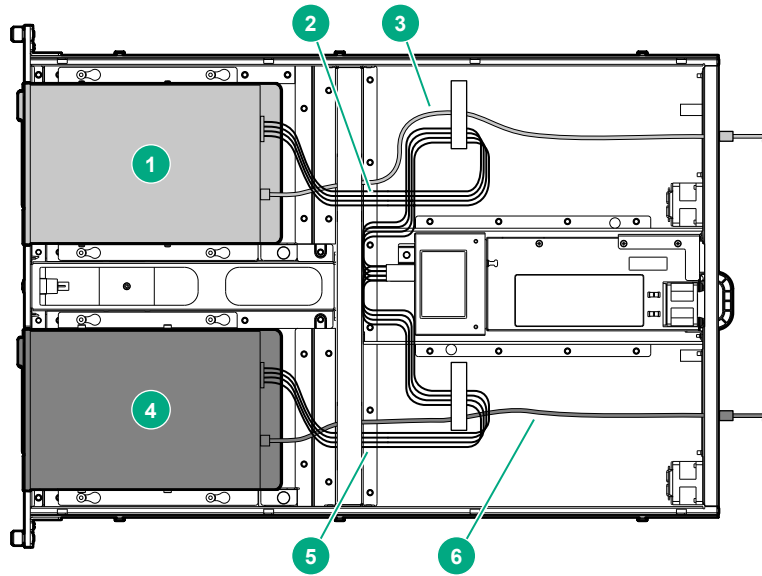

Figure 42: Internal cabling for two RDX drives

- | | |
|---------------------------------|---------------------------------|
| 1. Drive 1 | 2. Power cable used for drive 1 |
| 3. USB cable for drive 1 | 4. Drive 2 |
| 5. Power cable used for drive 2 | 6. USB cable for drive 2 |
9. Replace the top access panel.
If needed, lock the latch using a T15 Torx screwdriver.

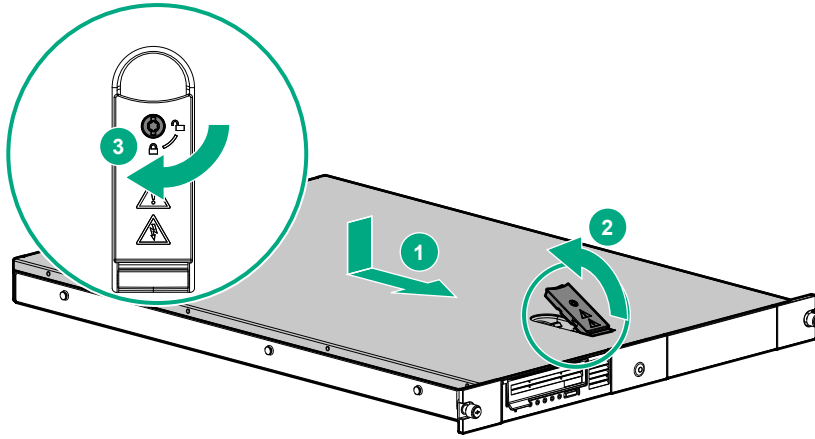

Figure 43: Replacing the access panel

10. Reinstall the enclosure in the rack, reattach cables, and then power on.
For instructions, see **Completing the installation**.

Replacing a drive

△ CAUTION:

To avoid damaging the equipment due to electrostatic discharge, be sure to review and practice the procedures in **Electrostatic Discharge** before handling the drives.

Prerequisites

Ensure all rack safety precautions stated in **Rack Safety** on page 18 have been implemented.

Procedure

1. Remove any tape cartridges or disk cartridges previously loaded. Verify that all host processes are idle. Power off the rack-mount enclosure.
2. Disconnect the power cord from the rear of the enclosure. Disconnect the data cables from the host.
3. Remove the rack-mount enclosure with the failed drive from the rack. Place it on a static-safe work surface.
 - a. Loosen the captive thumbscrews.
 - b. Press the retaining clips on each side of the enclosure.
 - c. Slide the enclosure forward and out of the rack.

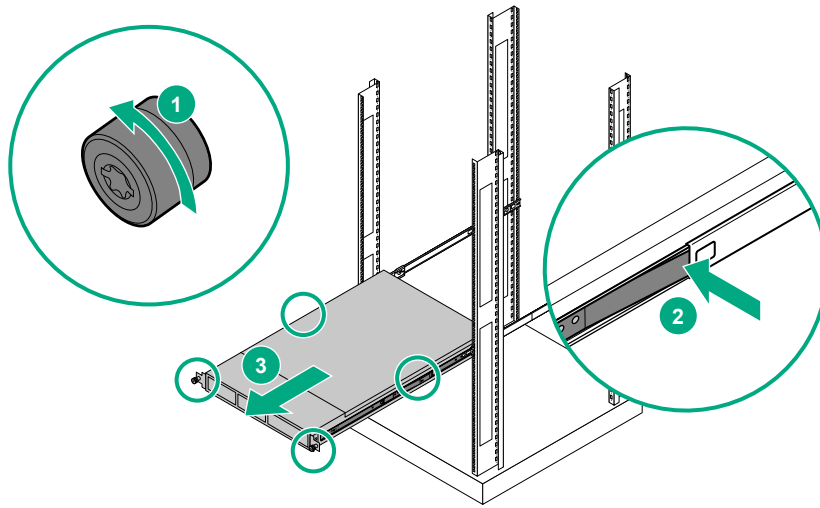

Figure 44: Removing the enclosure from the rack

4. Remove the top access panel.
Unlock the latch if necessary.

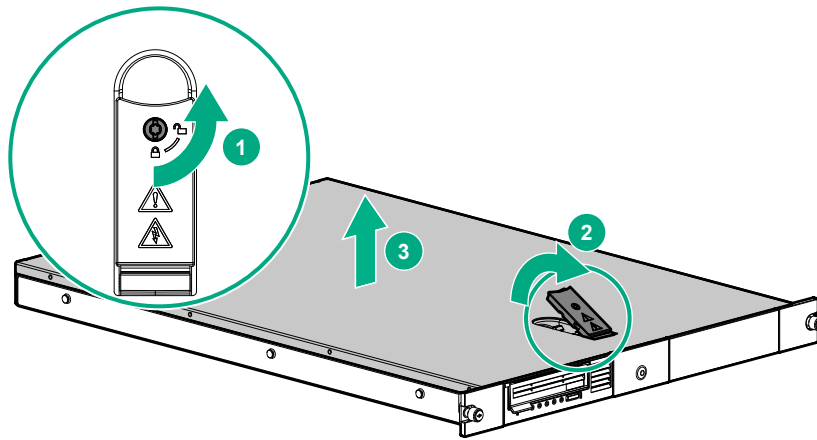

Figure 45: Removing the access panel

5. Disconnect the cables from the back of the drive.
6. Remove the drive from the enclosure.
 - a. Pull the spring-loaded button on the right mounting rail up.
 - b. Slide the drive forward and then lift.

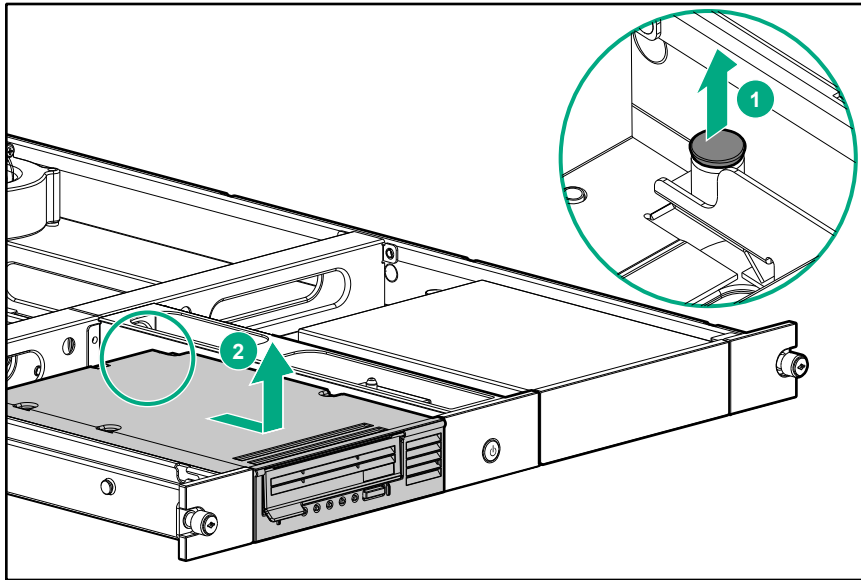

Figure 46: Removing the drive

7. Remove the mounting brackets from the drive.

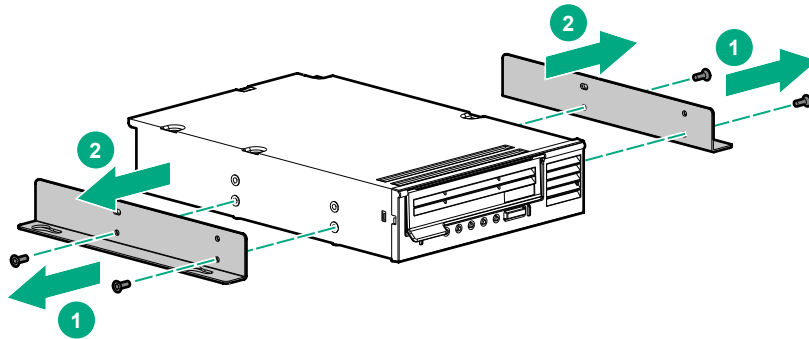

Figure 47: Removing the mounting brackets

8. Install the mounting brackets to the sides of the blank or replacement drive.

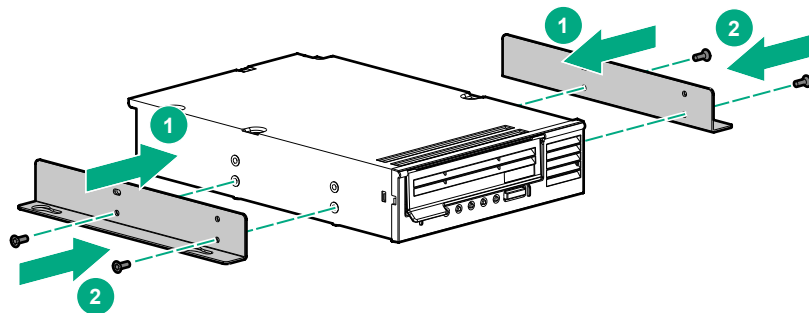

Figure 48: Installing the mounting brackets

⚠ CAUTION:

When installing an LTO half-height tape drive, it is important that you use the 4 mm M3 screws provided with the drive. If the screws are too long, they may damage the mechanism and void the warranty. Do not overtighten the screws.

9. Install the replacement drive or drive blank in the enclosure:
 - a. Position the mounting bracket keyhole slots over the mounting posts and then lower the drive.
 - b. Slide the drive toward the back of the enclosure.
 - c. The spring-loaded button will automatically snap into place.
10. Reattach the data and power cables to the rear of the drive.

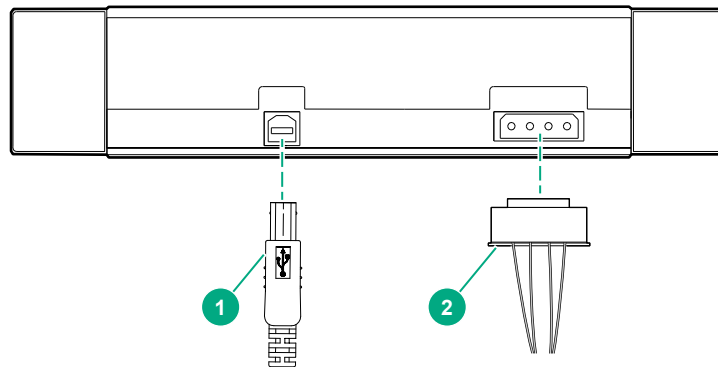

Figure 49: RDX drive cable connections

1	USB cable
2	Power cable

NOTE:

The drive side of the HPE-supported USB 3.0 cable assembly plug plastic housing is blue and will not connect to USB 2.0 devices.

The HPE-supported USB 2.0 cable assembly will connect to a USB 3.0 device. Using a USB 2.0 cable assembly with a USB 3.0 device will result in much slower data transfer.

Use the appropriate cable for your device.

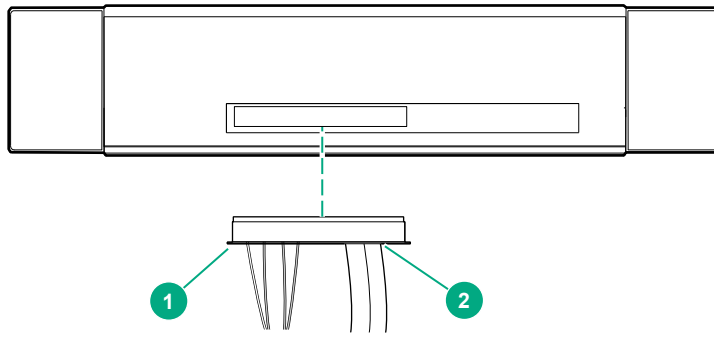

Figure 50: LTO 5, LTO 6, LTO 7, and LTO 8 cable connection

1	Power side of cable
2	Data side of cable

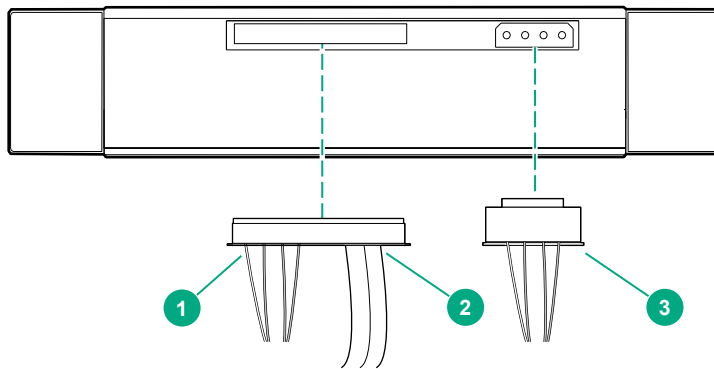

Figure 51: LTO 1, LTO 2, LTO 3, and LTO 4 cable connections

1	Power side of SAS cable - not used for LTO 1, LTO 2, LTO 3, and LTO 4 drives
2	Data side of SAS cable
3	Power cable

NOTE:

The power connector attached to the SAS cable will NOT be used in this case.

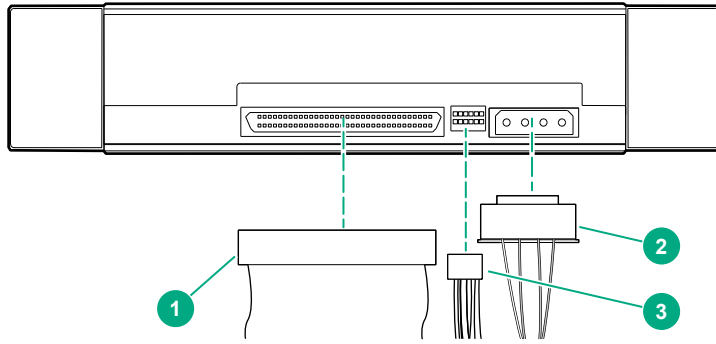

Figure 52: Parallel SCSI cable connection

1	Parallel SCSI cable
2	Power cable
3	SCSI ID switch



CAUTION:

To prevent possible data errors, when there is only one device on a SCSI bus, connect it to the SCSI port closest to the terminator.

11. Replace the top access panel.
If needed, lock the latch using a T15 Torx screwdriver.

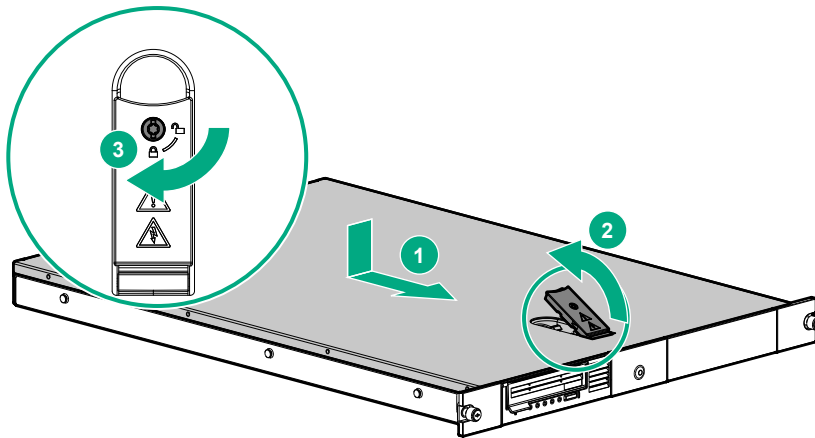

Figure 53: Replacing the access panel

12. Reinstall the enclosure in the rack, reattach cables, and then power on.
For instructions, see [Completing the installation](#).

Replacing the 1U enclosure chassis

When replacing the chassis, you will move the drives, cable bracket assemblies, and any chassis I/O blank panels to the new chassis.

Prerequisites

A 3/16 inch (5 mm) flat-blade screwdriver or T-15 Torx screwdriver might be required to install a drive in the enclosure.

Procedure

1. Remove any tape cartridges or disk cartridges previously loaded. Verify that all host processes are idle. Power off the rack-mount enclosure.
2. Disconnect the power cord from the rear of the enclosure. Disconnect the data cables from the host.
3. Remove the failed enclosure from the rack and place it on a static-safe work surface.
 - a. Loosen the thumbscrews.
 - b. Press the retaining clips on each side of the enclosure.
 - c. Slide the enclosure forward and out of the rack.

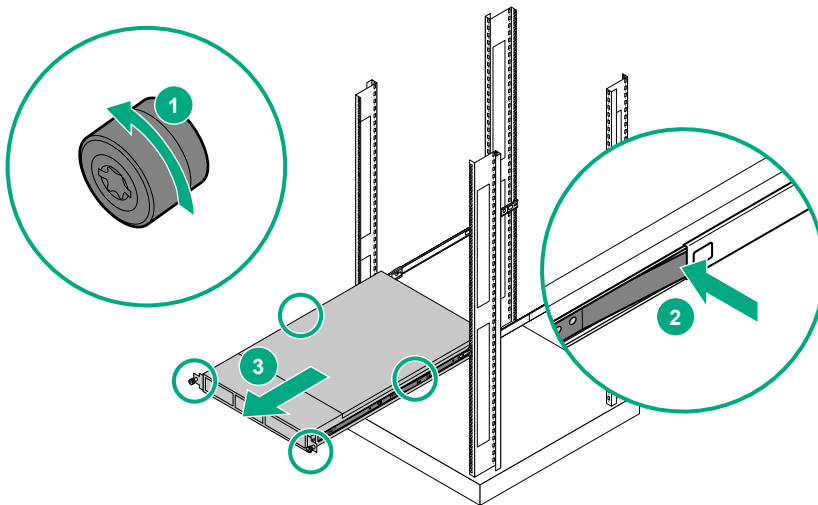

Figure 54: Removing an enclosure from the rack

4. Place the replacement enclosure chassis on the static safe work surface.
5. Remove the top access panels of both enclosures.
Unlock the latch if necessary.

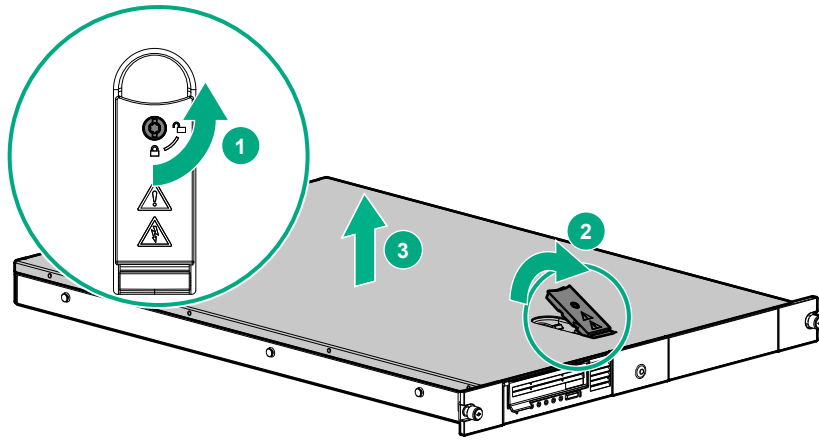

Figure 55: Removing the access panel

6. Move the drives, cables, and any chassis I/O blank panels from the failed enclosure to the replacement enclosure.
7. If the enclosure has a SAS repeater board that is working, consider your options:
 - Move the original repeater from the failed enclosure to the replacement enclosure. By moving the SAS repeater, you can continue using the same cabling to the host server.
For instructions, see **Moving the SAS repeater board to a replacement enclosure**.
 - Obtain new internal-external SAS cables that will replace the SAS repeater and connect to the host HBA. To review the cable alternatives, see the Quick Spec for the 1U Rack-mount Enclosure or Part Surfer (<http://partsurfer.hpe.com>).
8. Replace the access panels on both of the enclosures.
If needed, lock the latch using a T15 Torx screwdriver.

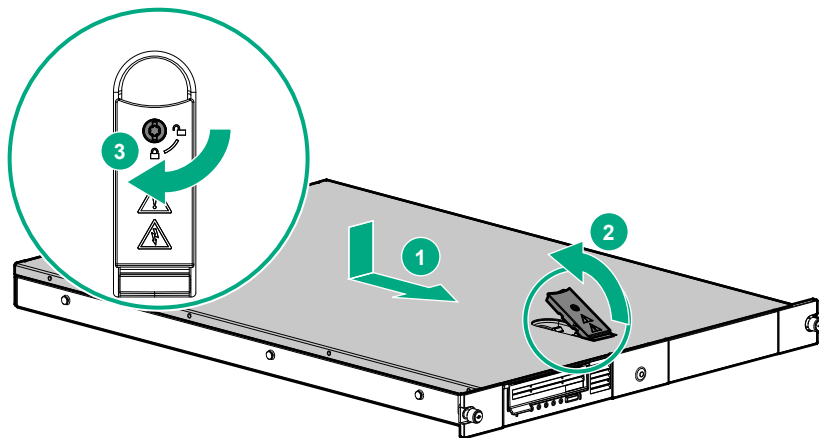

Figure 56: Replacing the access panel

9. Reinstall the enclosure in the rack, reattach cables, and then power on.
For instructions, see **Completing the installation**.

Moving the SAS repeater board to a replacement enclosure

The SAS repeater board is no longer available. If the repeater board continues to function, but the power supply or another chassis component failure occurs, consider swapping the original repeater into the replacement chassis. Otherwise, switch to the correct internal-external SAS cable suitable to connect to your HBA.

Procedure

1. Remove the SAS repeater board, internal SAS cables, and the SAS split power cable from the enclosure.

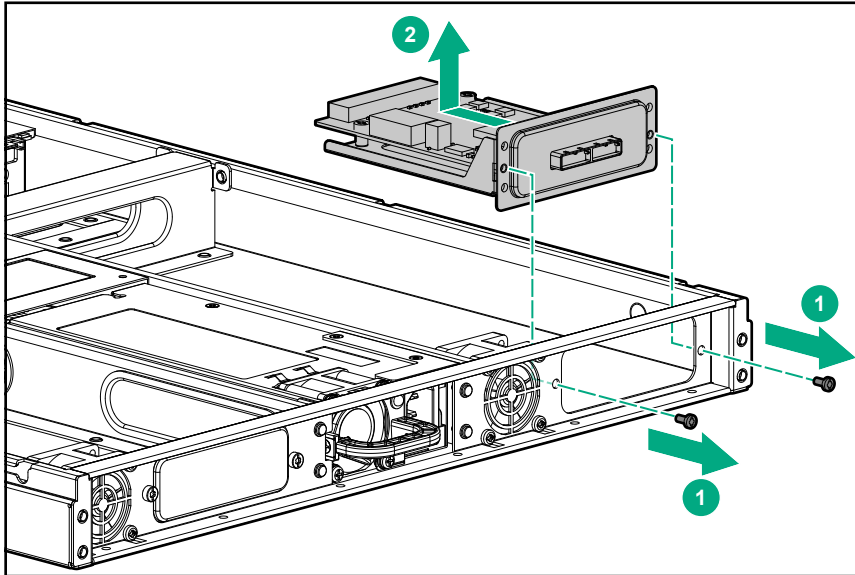

Figure 57: Removing the SAS repeater board

2. Install the SAS repeater board in the replacement enclosure.

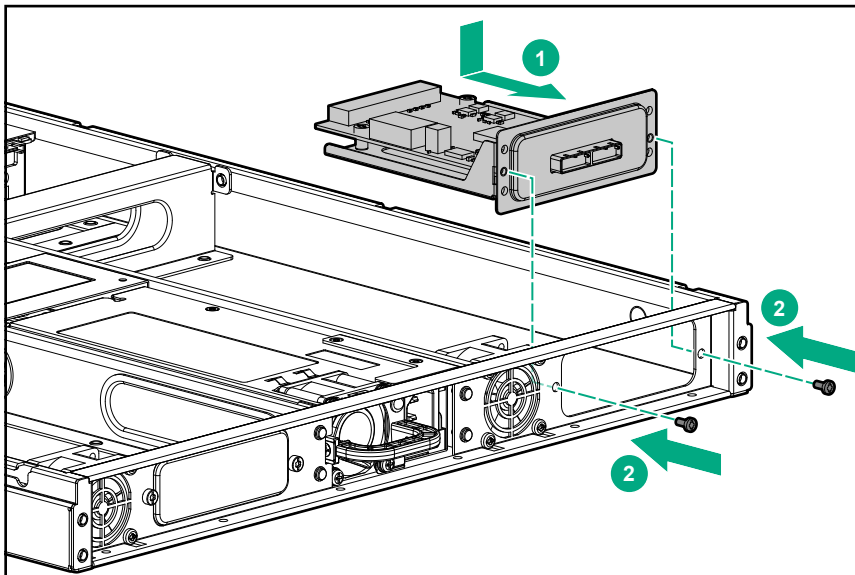

Figure 58: Installing the SAS repeater board in the enclosure

3. Route the internal SAS cables connected to the SAS repeater to the drives in the replacement chassis. Connect power to the drives and SAS repeater using the SAS split power cable.

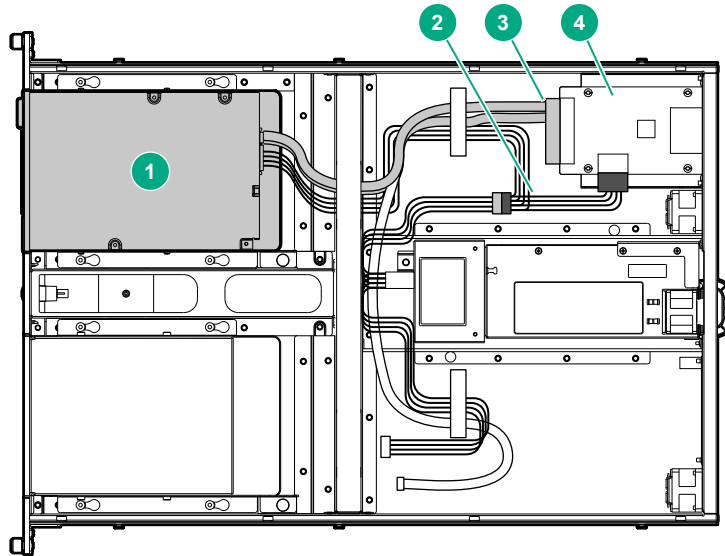

Figure 59: Components with the SAS repeater board

1. SAS LTO tape drive
2. Power cable
3. SAS data cable
4. SAS repeater board

Support and other resources

Accessing Hewlett Packard Enterprise Support

- For live assistance, go to the Contact Hewlett Packard Enterprise Worldwide website:
<http://www.hpe.com/assistance>
- To access documentation and support services, go to the Hewlett Packard Enterprise Support Center website:
<http://www.hpe.com/support/hpesc>

Information to collect

- Technical support registration number (if applicable)
- Product name, model or version, and serial number
- Operating system name and version
- Firmware version
- Error messages
- Product-specific reports and logs
- Add-on products or components
- Third-party products or components

Accessing updates

- Some software products provide a mechanism for accessing software updates through the product interface. Review your product documentation to identify the recommended software update method.
- To download product updates:

Hewlett Packard Enterprise Support Center

www.hpe.com/support/hpesc

Hewlett Packard Enterprise Support Center: Software downloads

www.hpe.com/support/downloads

Software Depot

www.hpe.com/support/softwaredepot

- To subscribe to eNewsletters and alerts:
www.hpe.com/support/e-updates
- To view and update your entitlements, and to link your contracts and warranties with your profile, go to the Hewlett Packard Enterprise Support Center **More Information on Access to Support Materials** page:

❗ **IMPORTANT:**

Access to some updates might require product entitlement when accessed through the Hewlett Packard Enterprise Support Center. You must have an HPE Passport set up with relevant entitlements.

Customer self repair

Hewlett Packard Enterprise customer self repair (CSR) programs allow you to repair your product. If a CSR part needs to be replaced, it will be shipped directly to you so that you can install it at your convenience. Some parts do not qualify for CSR. Your Hewlett Packard Enterprise authorized service provider will determine whether a repair can be accomplished by CSR.

For more information about CSR, contact your local service provider or go to the CSR website:

<http://www.hpe.com/support/selfrepair>

Remote support

Remote support is available with supported devices as part of your warranty or contractual support agreement. It provides intelligent event diagnosis, and automatic, secure submission of hardware event notifications to Hewlett Packard Enterprise, which will initiate a fast and accurate resolution based on your product's service level. Hewlett Packard Enterprise strongly recommends that you register your device for remote support.

If your product includes additional remote support details, use search to locate that information.

Remote support and Proactive Care information

HPE Get Connected

www.hpe.com/services/getconnected

HPE Proactive Care services

www.hpe.com/services/proactivecare

HPE Proactive Care service: Supported products list

www.hpe.com/services/proactivecaresupportedproducts

HPE Proactive Care advanced service: Supported products list

www.hpe.com/services/proactivecareadvancedsupportedproducts

Proactive Care customer information

Proactive Care central

www.hpe.com/services/proactivecarecentral

Proactive Care service activation

www.hpe.com/services/proactivecarecentralgetstarted

Warranty information

To view the warranty for your product or to view the *Safety and Compliance Information for Server, Storage, Power, Networking, and Rack Products* reference document, go to the Enterprise Safety and Compliance website:

www.hpe.com/support/Safety-Compliance-EnterpriseProducts

Additional warranty information

HPE ProLiant and x86 Servers and Options

www.hpe.com/support/ProLiantServers-Warranties

HPE Enterprise Servers

www.hpe.com/support/EnterpriseServers-Warranties

HPE Storage Products

www.hpe.com/support/Storage-Warranties

HPE Networking Products

www.hpe.com/support/Networking-Warranties

Regulatory information

To view the regulatory information for your product, view the *Safety and Compliance Information for Server, Storage, Power, Networking, and Rack Products*, available at the Hewlett Packard Enterprise Support Center:

www.hpe.com/support/Safety-Compliance-EnterpriseProducts

Additional regulatory information

Hewlett Packard Enterprise is committed to providing our customers with information about the chemical substances in our products as needed to comply with legal requirements such as REACH (Regulation EC No 1907/2006 of the European Parliament and the Council). A chemical information report for this product can be found at:

www.hpe.com/info/reach

For Hewlett Packard Enterprise product environmental and safety information and compliance data, including RoHS and REACH, see:

www.hpe.com/info/ecodata

For Hewlett Packard Enterprise environmental information, including company programs, product recycling, and energy efficiency, see:

www.hpe.com/info/environment

Documentation feedback

Hewlett Packard Enterprise is committed to providing documentation that meets your needs. To help us improve the documentation, send any errors, suggestions, or comments to Documentation Feedback (docsfeedback@hpe.com). When submitting your feedback, include the document title, part number, edition, and publication date located on the front cover of the document. For online help content, include the product name, product version, help edition, and publication date located on the legal notices page.

Legacy cable connections

Parallel SCSI cable connections

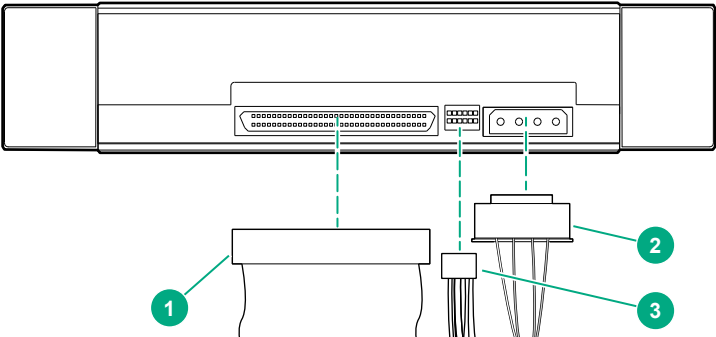

Figure 60: Parallel SCSI cable connections

1	Parallel SCSI cable
2	Power cable
3	SCSI ID switch

⚠ CAUTION:

To prevent data errors, when there is only one device on a SCSI bus, connect it to the SCSI port closest to the terminator.

LTO 1, LTO 2, LTO 3, and LTO 4 cable connections

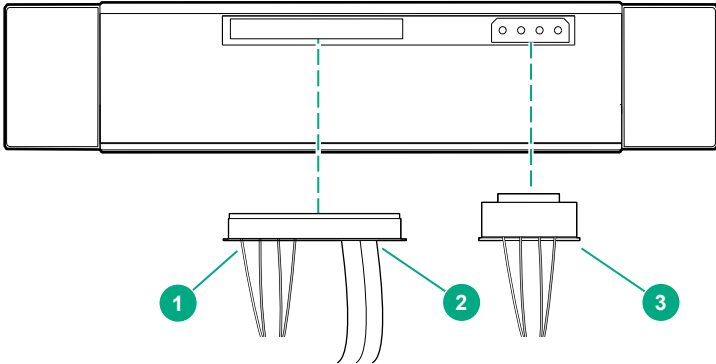

Figure 61: LTO 1, LTO 2, LTO 3, and LTO 4 cable connections

1	Power side of SAS cable - not used for LTO 1, LTO 2, LTO 3, and LTO 4 drives
2	Data side of SAS cable
3	Power cable

NOTE:

The power connector attached to the SAS cable will NOT be used.

Appendix: Specifications

Environmental specifications

Table 1: Environmental specifications

Characteristic	Specification		
	LTO-7 and LTO-8	LTO-5 and LTO-6	RDX
Temperature			
Operating	10° to 35° C up to 3000m 10° to 30° C above 3000m and up to 4000m	10° to 35° C	10° to 45° C
Storage	-30° to 60° C		-40° to 65° C
Temperature shock immunity — maximum rate of change	10° C per hour		
Miscellaneous			
Dust concentration	ISO 14644 -1 Class 8	less than 200 microgram / cubic meter	
Altitude	4000 meters (see operating temperature)	4000 meters	Operating: -15m to 3048m Non-operating: -15m to 10660m
Humidity			
Operating	20% to 80% RH (noncondensing, max wet bulb temperature = 26C)		
Nonoperating	10% to 90% RH noncondensing	10% to 95% RH noncondensing	8% to 90% RH noncondensing

Mechanical specifications

Table 2: Mechanical specifications

Characteristic	S.A.E	Metric
Height	1.7 in	4.32 cm
Width	19.0 in	42.88 cm
Depth	25.3 in	64.14 cm
Weight	20.0 lb	9.07 kg

Power supply specifications

Table 3: Electrical specifications

Input power requirements	S.A.E
Voltage	100 – 120/200-240 V 50/60 Hz
Current	2/1 A
Power	136 W (maximum value and applies to worst-case conditions at full rated power supply load)

Electrostatic discharge (ESD)

Preventing Electrostatic Discharge

To prevent damaging the system, be aware of the precautions you need to follow when setting up the system or handling parts. A discharge of static electricity from a finger or other conductor may damage system boards or other static-sensitive devices. This type of damage may reduce the life expectancy of the device.

To prevent electrostatic damage:

- Avoid hand contact by transporting and storing products in static-safe containers.
- Keep electrostatic-sensitive parts in their containers until they arrive at static-free workstations.
- Place parts on a grounded surface before removing them from their containers.
- Avoid touching pins, leads, or circuitry.
- Always be properly grounded when touching a static-sensitive component or assembly.

Grounding methods to prevent electrostatic discharge

Several methods are used for grounding. Use one or more of the following methods when handling or installing electrostatic-sensitive parts:

- Use a wrist strap connected by a ground cord to a grounded workstation or computer chassis. Wrist straps are flexible straps with a minimum of 1 megohm \pm 10 percent resistance in the ground cords. To provide proper ground, wear the strap snug against the skin.
- Use heel straps, toe straps, or boot straps at standing workstations. Wear the straps on both feet when standing on conductive floors or dissipating floor mats.
- Use conductive field service tools.
- Use a portable field service kit with a folding static-dissipating work mat.

If you do not have any of the suggested equipment for proper grounding, have an authorized reseller install the part.

For more information on static electricity or assistance with product installation, contact an authorized reseller.