



Hewlett Packard
Enterprise

HPE ProLiant ML350 Gen11 Server User Guide

Part Number: 30-D8158AF6-005
Published: June 2024
Edition: 5

HPE ProLiant ML350 Gen11 Server User Guide

Abstract

This document is for the person who installs, administers, and troubleshoots servers and storage systems. Hewlett Packard Enterprise assumes you are qualified in the servicing of computer equipment and trained in recognizing hazards in products with hazardous energy levels, and are familiar with the weight and stability precautions for rack installations.

Part Number: 30-D8158AF6-005

Published: June 2024

Edition: 5

© Copyright 2023–2024 Hewlett Packard Enterprise Development LP

Notices

The information contained herein is subject to change without notice. The only warranties for Hewlett Packard Enterprise products and services are set forth in the express warranty statements accompanying such products and services. Nothing herein should be construed as constituting an additional warranty. Hewlett Packard Enterprise shall not be liable for technical or editorial errors or omissions contained herein.

Confidential computer software. Valid license from Hewlett Packard Enterprise required for possession, use, or copying. Consistent with FAR 12.211 and 12.212, Commercial Computer Software, Computer Software Documentation, and Technical Data for Commercial Items are licensed to the U.S. Government under vendor's standard commercial license.

Links to third-party websites take you outside the Hewlett Packard Enterprise website. Hewlett Packard Enterprise has no control over and is not responsible for information outside the Hewlett Packard Enterprise website.

Acknowledgments

Intel®, Intel® Virtual RAID on CPU (Intel® VROC), and Xeon® are trademarks of Intel Corporation in the U.S. and other countries.

Linux® is the registered trademark of Linus Torvalds in the U.S. and other countries.

Microsoft®, Windows®, and Windows Server® are either registered trademarks or trademarks of Microsoft Corporation in the United States and/or other countries.

VMware® is a registered trademark or trademark of VMware, Inc. and its subsidiaries in the United States and other jurisdictions.

All third-party marks are property of their respective owners.

Table of contents

- Component identification
 - Front panel components
 - iLO Service Port
 - Front panel LEDs and button
 - Server UID LED
 - Using the UID button to view the Server Health Summary
 - Front panel LED power fault codes
 - Rear panel components
 - Display device setup
 - Rear panel LEDs
 - System board components
 - System maintenance switch descriptions
 - DIMM label identification
 - DIMM slot numbering
 - Heatsink and processor socket components
 - Internal components
 - Riser board components
 - Riser slot numbering
 - HPE Basic Drive LED definitions
 - EDSFF SSD LED definitions
 - Drive bay numbering
 - LFF drive bay numbering
 - SFF drive bay numbering
 - Mixed drive bay numbering
 - E3.S drive bay numbering
 - Drive backplane naming
 - Fan bay numbering
 - Media device screws
 - Trusted Platform Module 2.0
 - Trusted Platform Module 2.0 guidelines
 - BitLocker recovery key/password retention guidelines
 - HPE NS204i-u Boot Device components
 - HPE NS204i-u Boot Device LED definitions
- Setup
 - Initial system installation
 - HPE Installation Service
 - Intel VROC support
 - Setting up the server
 - Removing the shipping brackets

- Operational requirements
 - Space and airflow requirements
 - Temperature requirements
 - Power requirements
 - Electrical grounding requirements
- Rack warnings and cautions
- Server warnings and cautions
- Electrostatic discharge
- Operations
 - Power down the server
 - Extend the server from the rack
 - Remove the server from the rack
 - Remove the front bezel
 - Position the tower server for hardware configuration
 - Remove the access panel
 - Remove the fan cage
 - Remove the primary riser cage
 - Remove the secondary riser cage blank
 - Remove the secondary riser cage
 - Remove the HPE NS204i-u Boot Device
 - Install the primary/secondary riser cage
 - Install the fan cage
 - Install the access panel
 - Position the tower server for operation
 - Install the front bezel
 - Install the server into the rack
 - Power up the server
 - Installing the shipping hardware
- Hardware options installation
 - Server data backup
 - Hardware option installation guidelines
 - Hewlett Packard Enterprise product QuickSpecs
 - Tower-to-rack conversion kit
 - Installing the tower-to-rack conversion kit
 - Install the rack rails and server tray
 - Install the server into the rack
 - Install the cable management arm
 - Drive options
 - Drive installation guidelines
 - Installing a hot-plug LFF/SFF drive
 - Installing a hot-plug E3.S drive

- Power supply options
 - Hot-plug power supply calculations
 - Power supply warnings and cautions
 - DC power supply warnings and cautions
 - DC power supply wire colors
 - Installing an AC power supply
 - Installing a DC power supply
 - Connecting a DC power cable to a DC power source
- Drive cage options
 - Installing the 4 LFF drive cage
 - Installing the 8 SFF drive cage
- Media device options
 - USB RDX backup system option
 - Installing a USB RDX docking station
 - Enable the increased cooling mode
 - Optical drive option
 - Installing an optical drive
- Transceiver option
 - Transceiver warnings and cautions
 - Installing a transceiver
- Fan options
 - Fan population
 - Fan redundancy support
 - Fan mode behavior
 - Installing an internal fan
 - Installing the external fan
- Memory option
 - HPE SmartMemory speed and population information
 - DIMM installation guidelines
 - Installing a DIMM
- Secondary riser cage and tertiary riser options
 - Installing the secondary riser cage
 - Installing the tertiary riser
- Storage controller options
 - Preparing the server for storage controller installation
 - Installing a type-p storage controller
 - Installing a type-o storage controller
- Energy pack options
 - HPE Smart Storage Battery
 - HPE Smart Storage Hybrid Capacitor
 - Minimum firmware versions

- Installing an energy pack
- Expansion card options
 - Accelerator options
 - Accelerator installation guidelines
 - Installing an expansion card on the primary/secondary riser cage
 - Installing an expansion card on the tertiary riser
- Processor heatsink assembly option
 - Processor cautions
 - Installing the processor heatsink assembly
- HPE NS204i-u Boot Device option
 - NS204i-u enablement option
 - Installing the HPE NS204i-u Boot Device
- OCP NIC 3.0 adapter option
 - OCP slot population rules
 - Installing the OCP NIC 3.0 adapter
- Chassis intrusion detection switch option
 - Installing the chassis intrusion detection switch
- Serial port option
 - Installing the serial port
- Internal USB device options
 - Installing an internal USB device
- Cabling
 - Cabling guidelines
 - Cabling diagrams
 - Internal cabling management
 - Storage cabling
 - Storage controller cabling
 - Drive power cabling
 - Energy pack cabling
 - Storage controller backup power cabling
 - Media device cabling
 - USB RDX docking station cabling
 - Optical drive cabling
 - GPU auxiliary power cabling
 - Fan cabling
 - HPE NS204i-u Boot Device cabling
 - OCP upgrade cabling
 - Tertiary riser signal cabling
 - Serial port cabling
 - Chassis intrusion detection switch cabling
 - Front I/O cabling

- Configuration resources
 - Updating firmware or system ROM
 - Configuring the server
 - Configuring storage controllers
 - Managing the HPE NS204i-u Boot Device
 - Deploying an OS
 - Configuring security
 - Optimizing the server
 - Server management
 - Managing Linux-based high performance compute clusters
- Troubleshooting
 - NMI functionality
 - Troubleshooting resources
- System battery replacement
 - System battery information
 - Removing and replacing the system battery
- Safety, warranty, and regulatory information
 - Regulatory information
 - Notices for Eurasian Economic Union
 - Turkey RoHS material content declaration
 - Ukraine RoHS material content declaration
 - Warranty information
- Specifications
 - Environmental specifications
 - Limited operating inlet ambient temperature requirements
 - Limited operating inlet ambient temperature requirements for DDR5 4800 256 GB DIMM
 - Limited operating inlet ambient temperature requirements for HPE InfiniBand HDR100 / Ethernet 100GB 2-port QSFP56 PCIe4 x16 Adapter
 - Limited operating inlet ambient temperature requirements for HPE NS204i-u Boot Device
 - Limited operating inlet ambient temperature requirements for E3.S drive configuration
 - Mechanical specifications
 - Power supply specifications
 - HPE 500 W Flex Slot Platinum Hot-plug Low Halogen Power Supply
 - HPE 800 W Flex Slot Platinum Hot-plug Low Halogen Power Supply
 - HPE 1000 W Flex Slot Titanium Hot-plug Power Supply
 - HPE 1600 W Flex Slot Platinum Hot-plug Low Halogen Power Supply
 - HPE 1600 W Flex Slot -48 VDC Hot-plug Power Supply
 - HPE 1800-2200 W Flex Slot Titanium Power Supply
- Websites
- Support and other resources
 - Accessing Hewlett Packard Enterprise Support

- [HPE product registration](#)
- [Accessing updates](#)
- [Customer self repair](#)
- [Remote support](#)
- [Documentation feedback](#)

Component identification

This chapter describes the external and internal server features and components.

Subtopics

[Front panel components](#)

[Front panel LEDs and button](#)

[Rear panel components](#)

[Rear panel LEDs](#)

[System board components](#)

[Internal components](#)

[Riser board components](#)

[Riser slot numbering](#)

[HPE Basic Drive LED definitions](#)

[EDSFF SSD LED definitions](#)

[Drive bay numbering](#)

[Drive backplane naming](#)

[Fan bay numbering](#)

[Media device screws](#)

[Trusted Platform Module 2.0](#)

[HPE NS204i-u Boot Device components](#)

[HPE NS204i-u Boot Device LED definitions](#)

Front panel components

4/8/12 LFF drive configuration



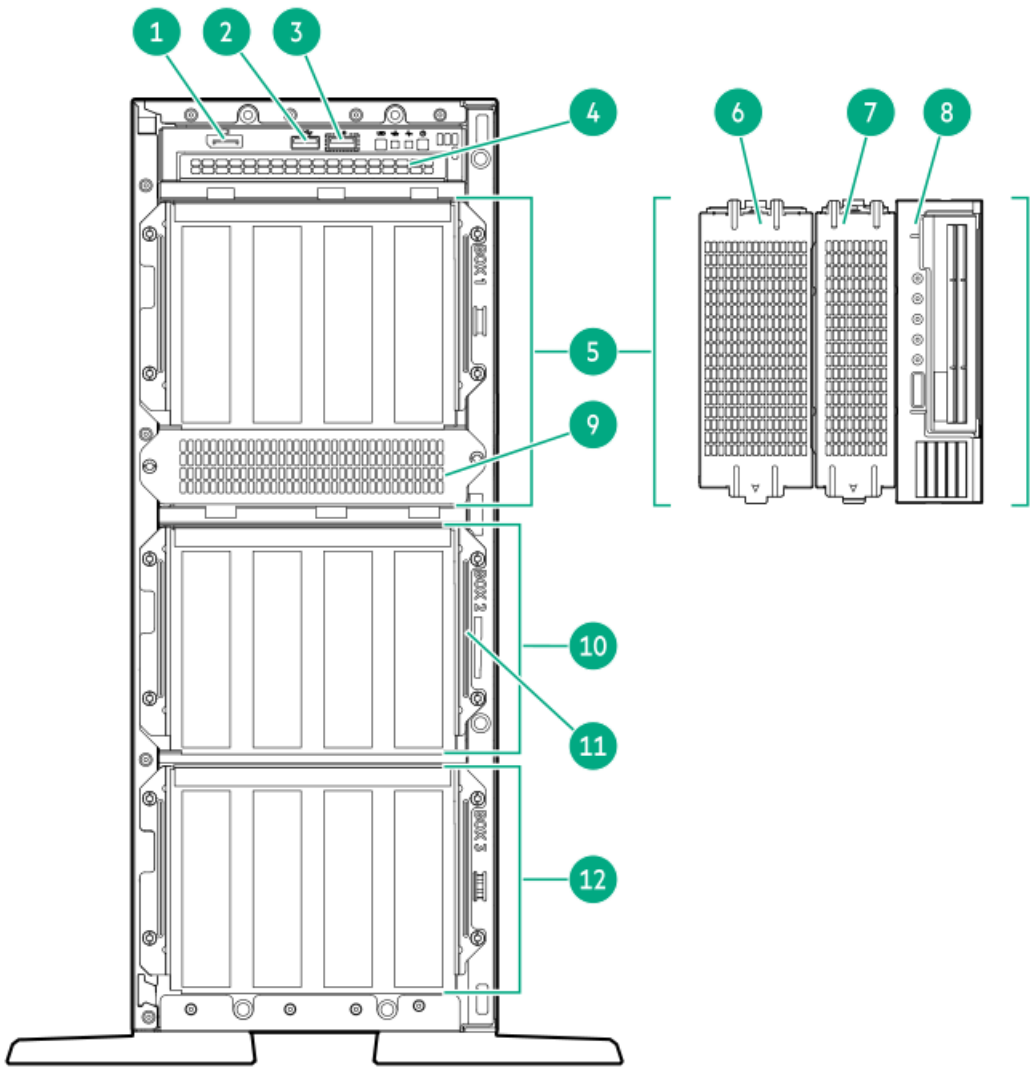

8/16/24 SFF drive configuration



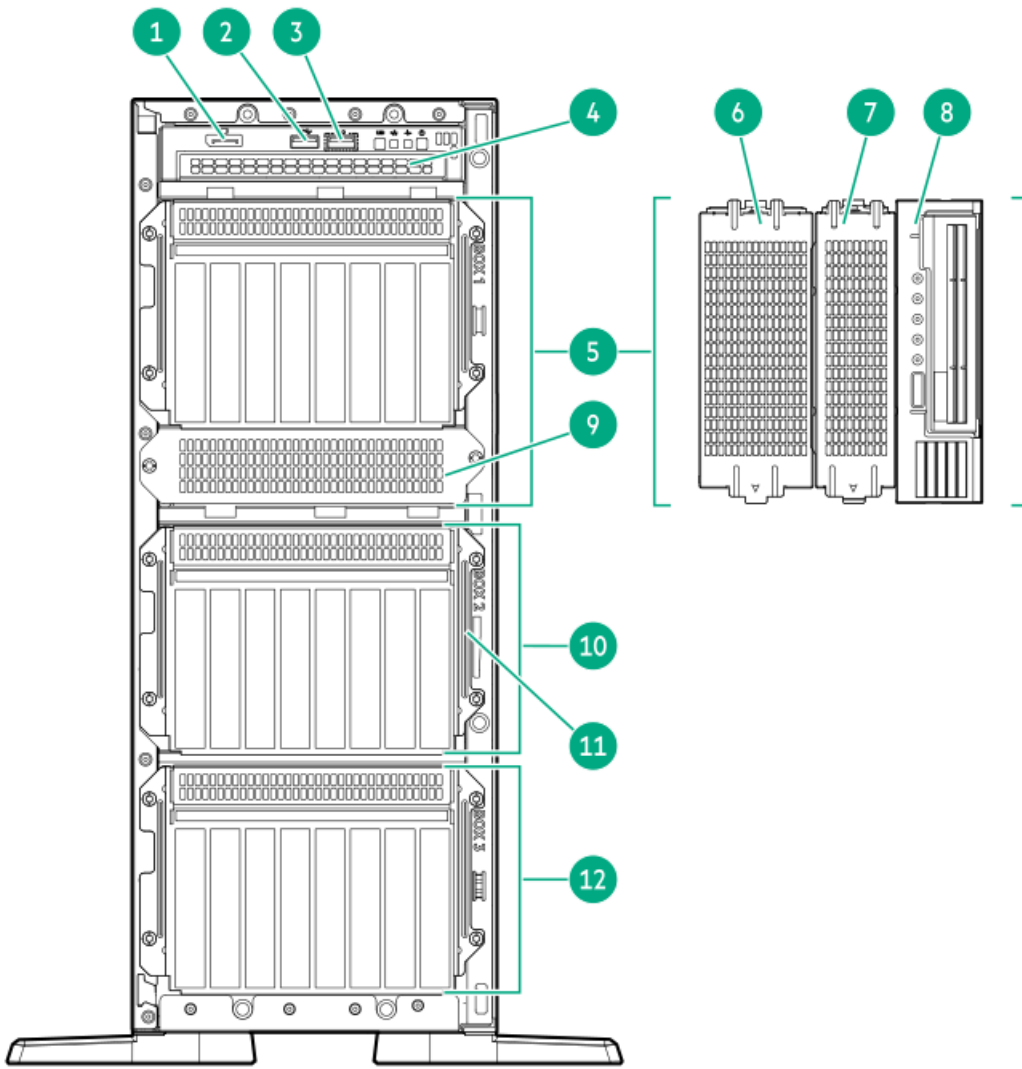

12 E3.S drive configuration



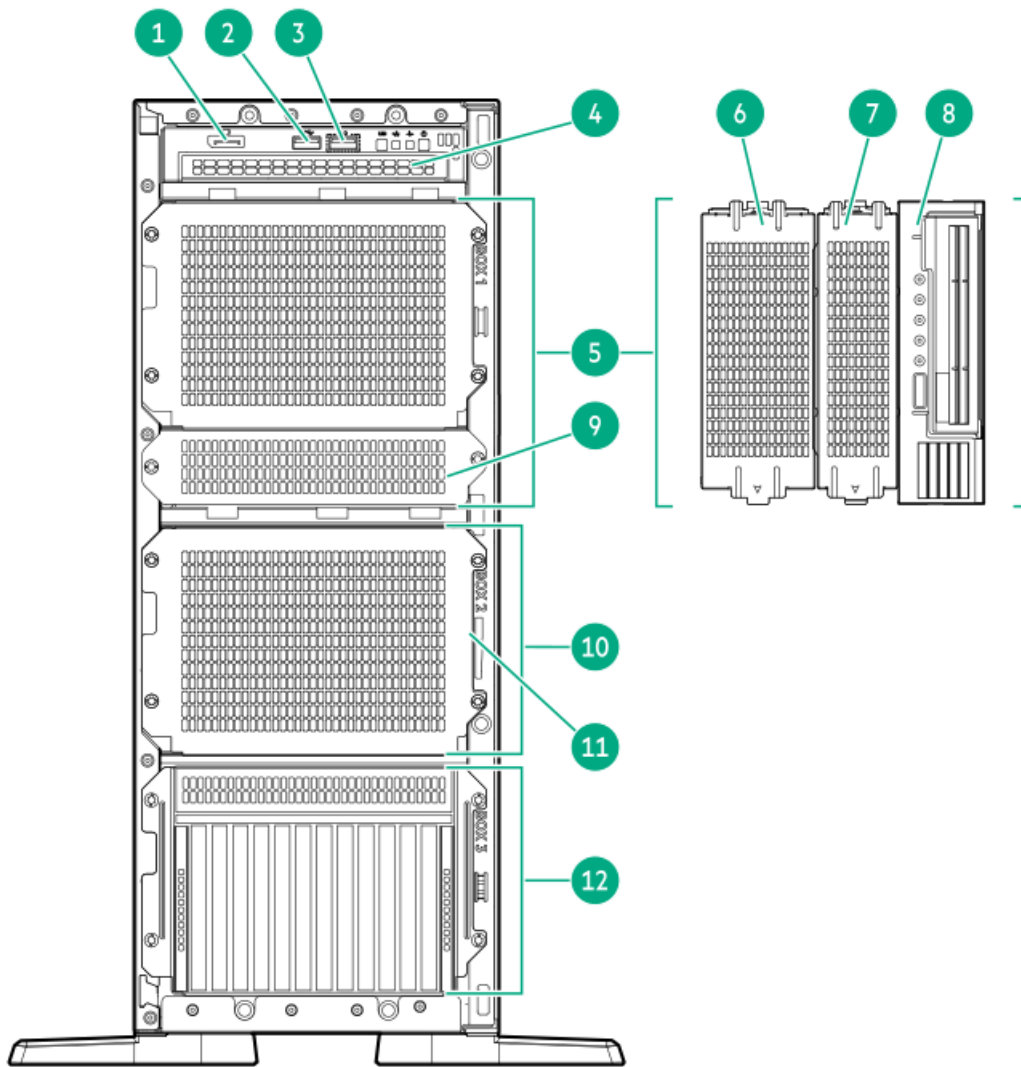

Item	Description
1	DisplayPort 1.1a
2	USB 3.2 Gen 1 port
3	iLO service port
4	Optical drive bay
5	Box 1 ^{1 2 3}
6	Full-height media bay blank
7	Media bay 2
8	Media bay 1
9	Media bay filler panel
10	Box 2 ^{1 3}
11	Serial number/iLO information pull tab ⁴
12	Box 3 ^{1 5 6}

- ¹ All three boxes support LFF and SFF drive cage options. This server supports mixed LFF + SFF hot-plug drive configurations.
- ² Box 1 also supports USB RDX docking station.
- ³ The x1 NVMe drives are supported in Box 1-2.
- ⁴ The serial number/iLO information pull tab is double-sided. One side shows the server serial number and the customer asset tag label. The other side shows the default iLO account information.
- ⁵ E3.S drives are supported in Box 3. When the E3.S drives are installed, LFF/SFF drives are not supported in Boxes 1 and 2. Two



processors are required for E3.S drive installation.

6 The x1 and x4 NVMe drives are supported in Box 3. The x4 NVMe drive backplane cannot be installed with other drive backplane types.

Subtopics

iLO Service Port

iLO Service Port

The Service Port is a USB port with the label **iLO** on supported servers and compute modules.

To find out if your server or compute module supports this feature, see the server specifications document at the following website:
<https://www.hpe.com/info/quickspecs>.

The Service Port is a USB port with the label **iLO** on the front of the server.

To find out if your server supports this feature, see the server specifications document at the following website:
<https://www.hpe.com/info/quickspecs>.

When you have physical access to a server, you can use the Service Port to do the following:

- Download the Active Health System Log to a supported USB flash drive.

When you use this feature, the connected USB flash drive is not accessible by the host operating system.

- Connect a client (such as a laptop) with a supported USB to Ethernet adapter to access the following:
 - iLO web interface
 - Remote console
 - iLO RESTful API
 - CLI

When you use the iLO Service Port:

- Actions are logged in the iLO event log.
- The server UID flashes to indicate the Service Port status.

You can also retrieve the Service Port status by using a REST client and the iLO RESTful API.

- You cannot use the Service Port to boot any device within the server, or the server itself.
- You cannot access the server by connecting to the Service Port.
- You cannot access the connected device from the server.

Front panel LEDs and button



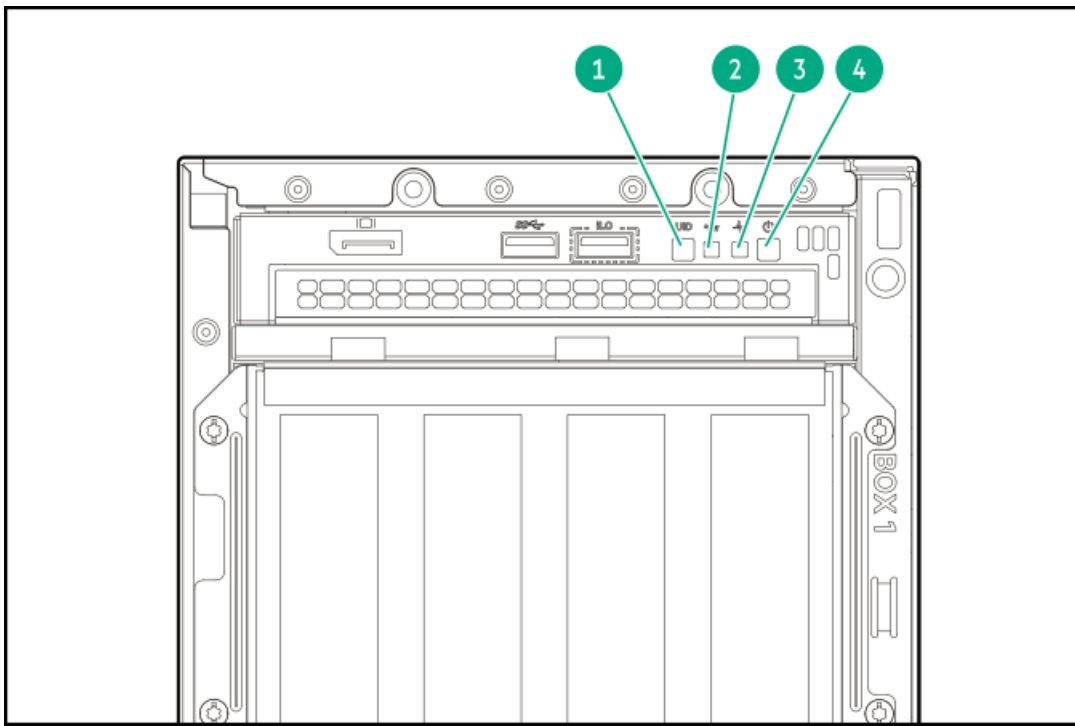

Item	Description	Status	Definition
1	UID button/LED ¹	Solid blue	Activated
		Flashing blue	<ul style="list-style-type: none"> 1 flash per second—Remote management or firmware upgrade in progress 4 flashes per second—iLO manual reboot sequence initiated 8 flashes per second—iLO manual reboot sequence in progress
		Off	Deactivated
2	NIC status LED ¹	Solid green	Linked to network
		Flashing green	Network active
		Off	No network activity
3	Health LED ¹	Solid green	Normal
		Flashing green	iLO is rebooting
		Flashing amber	System degraded ²
		Flashing red	System critical ²
4	Power On/Standby button and system power LED ¹	Solid green	System on
		Flashing green	Performing power-on sequence
		Solid amber	System in standby
		Off	No power present ³

¹ When all LEDs described in this table flash simultaneously, a power fault has occurred. For more information, see [Front panel LED power fault codes](#).

² If the health LED indicates a degraded or critical state, review the system [Integrated Management Log \(IML\)](#) or use [HPE iLO to review the system health status](#).

³ Facility power is not present, power cord is not attached, no power supplies are installed, power supply failure has occurred, or the front I/O cable is disconnected.

Subtopics

Server UID LED

Using the UID button to view the Server Health Summary

Front panel LED power fault codes

Server UID LED

The UID LED is used to locate a particular server when it is deployed in a dense rack with other equipment. Activating the UID LED helps an on-site technician to quickly identify a server for maintenance tasks.

Using the UID button to view the Server Health Summary

Prerequisites

- An external monitor is connected.
- In the iLO web interface, the Show Server Health on External Monitor feature is enabled on the Access Settings page.

About this task

Use the UID button to display the iLO Server Health Summary screen on an external monitor. This function works when the server is powered on or off. Use this feature for troubleshooting if the server will not start up.



CAUTION: Press and release the UID button. Holding it down at any time for more than five seconds initiates a graceful iLO reboot or a hardware iLO reboot. Data loss or NVRAM corruption might occur during a hardware iLO reboot.

Procedure

1. Press and release the UID button.

The Server Health Summary screen is displayed on the external monitor. For more information, see the iLO troubleshooting guide:

<https://www.hpe.com/support/ilo6>

2. Press the UID button again to close the Server Health Summary screen.

Front panel LED power fault codes

The following table provides a list of power fault codes, and the subsystems that are affected. Not all power faults are used by all servers.



Subsystem	LED behavior
System board	1 flash
Processor	2 flashes
Memory	3 flashes
Riser board PCIe slots	4 flashes
FlexibleLOM	5 flashes
Storage controller	6 flashes
System board PCIe slots	7 flashes
Power backplane	8 flashes
Storage backplane	9 flashes
Power supply	10 flashes
PCIe expansion cards installed in riser board	11 flashes
Chassis	12 flashes
GPU card	13 flashes

Rear panel components



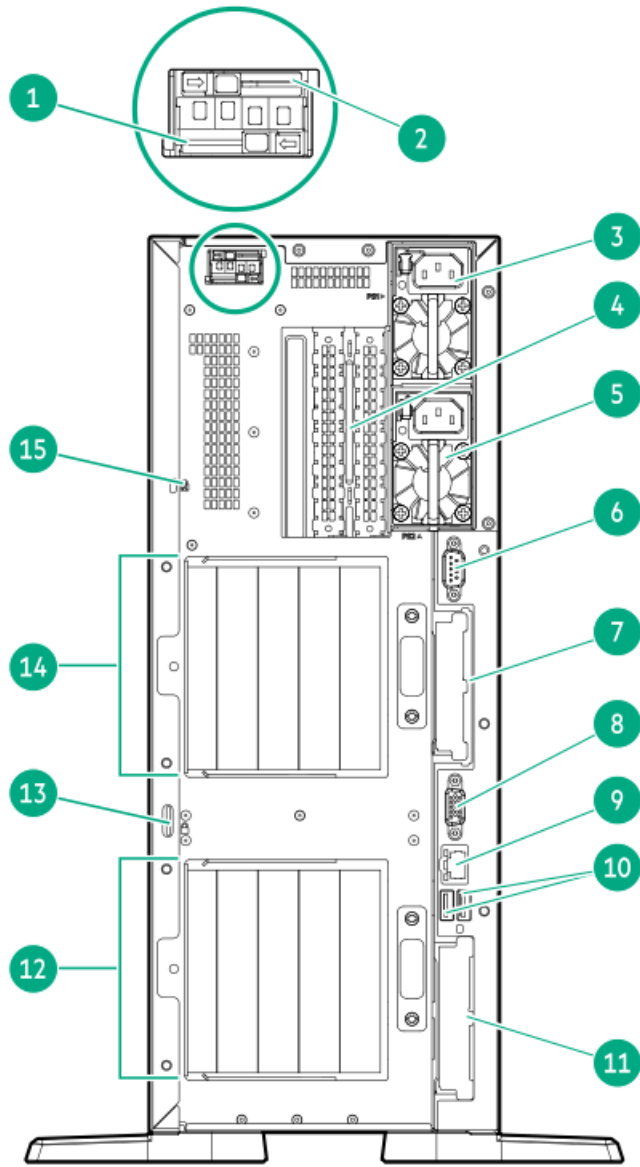

Item	Description
1	NS204i-u device slot 1 (optional)
2	NS204i-u device slot 2 (optional)
3	Flexible Slot power supply 1
4	Slots 9–10 PCIe5 x8 (tertiary riser) ¹
5	Flexible Slot power supply 2 (optional)
6	VGA port
7	Slot 15 OCP PCIe5 x16 ²
8	Serial port (optional)
9	iLO management port
10	USB 3.2 Gen 1 ports (2)
11	Slot 14 OCP PCIe5 x16 ³
12	Slots 1–4 PCIe5 (primary riser) ⁴
13	Padlock eye
14	Slots 5–8 PCIe5 (secondary riser) ^{1, 4}
15	Kensington slot

¹ Two processors are required for installing the secondary riser option. The same is required for a tertiary riser option used for NIC card installation.

² This slot supports an OCP NIC adapter.

³ This slot supports an OCP NIC adapter or a type-o storage controller.

⁴ Primary/secondary riser cage supports two riser boards.

Subtopics

Display device setup

Display device setup

This server supports both VGA port and DisplayPort 1.1a. Before connecting a display device to this server, review the following information:

- Whenever possible, use the same display connection type. For example, if your PC or monitor only has a VGA output, connect it to the server VGA port. Use of any kind of adapter or converter cable or dongle might lead to decreased display quality or a lag over the connection.
- DisplayPort connection: When connecting an HDMI or DVI display to the DisplayPort, use an active type adapter. Passive type adapter—marked with the DP++ symbol—is not supported.
- Display output modes:
 - If you connect two display devices to the VGA port and DisplayPort, the same image is shown on both devices—screen mirroring mode.
 - The embedded video controller in the iLO 6 chipset does not support dual display or screen extension mode. To enable dual display mode, install a compatible PCIe5 graphics card that supports this feature in the expansion slot.

Rear panel LEDs



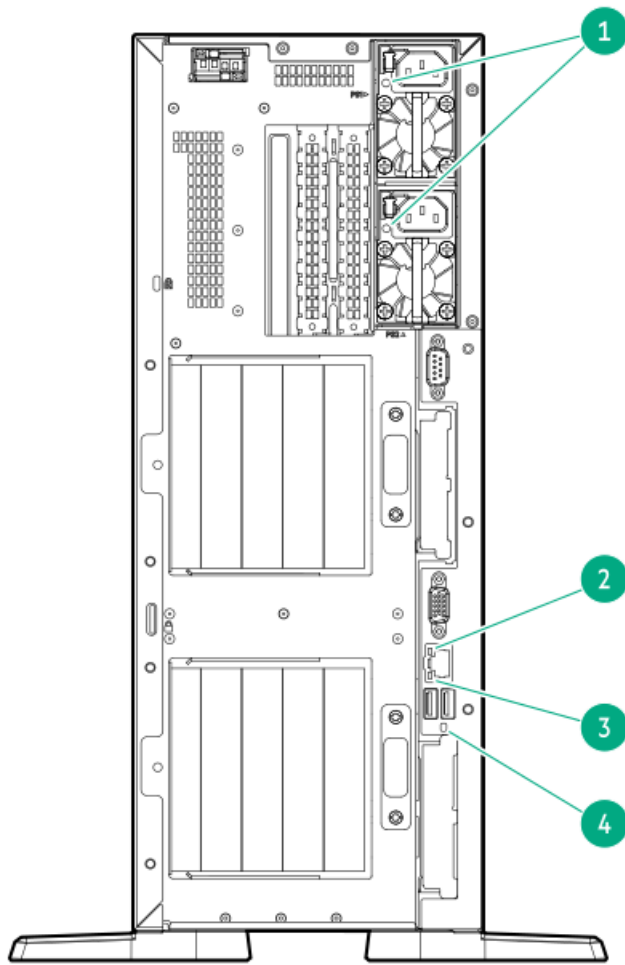

Item	Description	Status	Definition
1	Power supply	Solid green	The power supply is operating normally.
		Off	One or more of the following conditions exists: <ul style="list-style-type: none"> • Power is unavailable. • Power supply failure • Power supply is in standby mode. • Power supply error • Front I/O cable is disconnected.
2	iLO status	Solid green	Linked to network
		Flashing green	Network active
		Off	No network activity
3	iLO link	Solid green	Network link
		Off	No network link
4	UID	Solid blue	Activated
		Flashing blue	<ul style="list-style-type: none"> • 1 flash per second—Remote management or firmware upgrade in progress • 4 flashes per sec—iLO manual reboot sequence initiated • 8 flashes per sec—iLO manual reboot sequence in progress
		Off	Deactivated
		Off	Deactivated



System board components

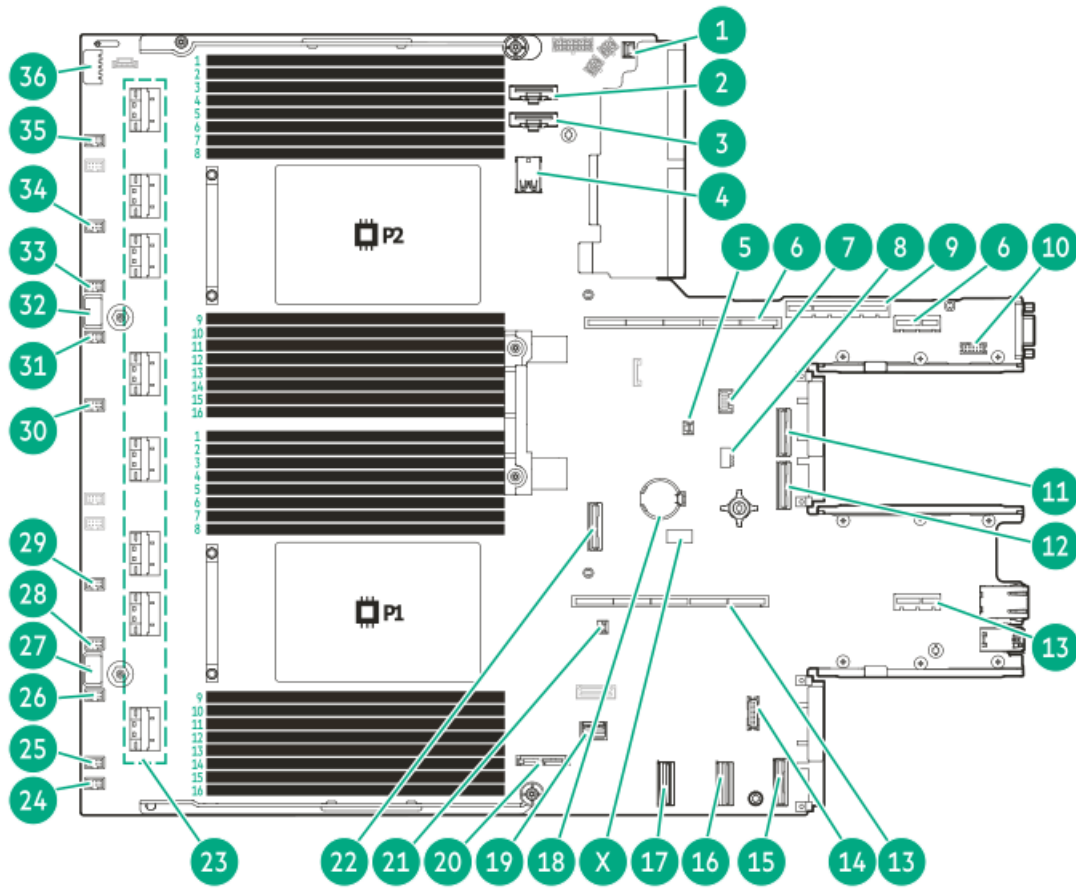

Item	Description
1	Chassis intrusion detection switch connector
2	CPU 2 MCIO port 2
3	CPU 2 MCIO port 1
4	Stacked, dual USB ports ¹
5	Slot 15 OCP storage backup power connector
6	Secondary riser connectors
7	Energy pack connector
8	NS204i-u power connector
9	Tertiary riser sideband connector
10	Serial port connector
11	Slot 15 OCP port 1
12	Slot 15 OCP port 2
13	Primary riser connectors
14	DisplayPort connector
15	Slot 14 OCP port 2
16	PCH LP SlimSAS port 2 ²
17	PCH LP SlimSAS port 1 ²
18	System battery
19	Front I/O & USB 3.2 Gen 1 port connector
20	Optical drive SATA-power connector
21	Slot 14 OCP storage backup power connector
22	CPU 1 MCIO port 1
23	x8 SlimSAS ports ³
24	Fan connector 10
25	Fan connector 4
26	Fan connector 8
27	Drive box 3 power connector
28	Fan connector 7
29	Fan connector 3
30	Fan connector 2
31	Fan connector 6
32	Drive box 2 power connector
33	Fan connector 5
34	Fan connector 1
35	Fan connector 9
36	Drive box 1 power connector
X	<u>System maintenance switch</u>

¹ Top = USB 3.2 Gen 1 port, Bottom = USB 2.0 port

² Used for SATA 6 Gb/s connections

³ The SlimSAS ports are numbered 1B-4B, 1A-4A from top to bottom. B is for CPU 2 and A is for CPU 1.

Subtopics



System maintenance switch descriptions

DIMM label identification

DIMM slot numbering

Heatsink and processor socket components

System maintenance switch descriptions

Position	Default	Function
S1 ¹	Off	<ul style="list-style-type: none">Off—iLO 6 security is enabled.On—iLO 6 security is disabled.
S2	Off	Reserved
S3	Off	Reserved
S4	Off	Reserved
S5 ¹	Off	<ul style="list-style-type: none">Off—Power-on password is enabled.On—Power-on password is disabled.
S6 ^{1, 2, 3}	Off	<ul style="list-style-type: none">Off—No functionOn—Restore default manufacturing settings
S7	Off	Reserved
S8	Off	Reserved
S9	Off	Reserved
S10	Off	Reserved
S11	Off	Reserved
S12	Off	Reserved

¹ To access the redundant ROM, set S1, S5, and S6 to On.

² When the system maintenance switch position 6 is set to the On position, the system is prepared to restore all configuration settings to their manufacturing defaults.

³ When the system maintenance switch position 6 is set to the On position and Secure Boot is enabled, some configurations cannot be restored. For more information, see [Configuring the server](#).

DIMM label identification

To determine DIMM characteristics, see the label attached to the DIMM. The information in this section helps you to use the label to locate specific information about the DIMM.

For more information about product features, specifications, options, configurations, and compatibility, see the [HPE DDR5 SmartMemory QuickSpecs](#):

<https://www.hpe.com/docs/server-memory>

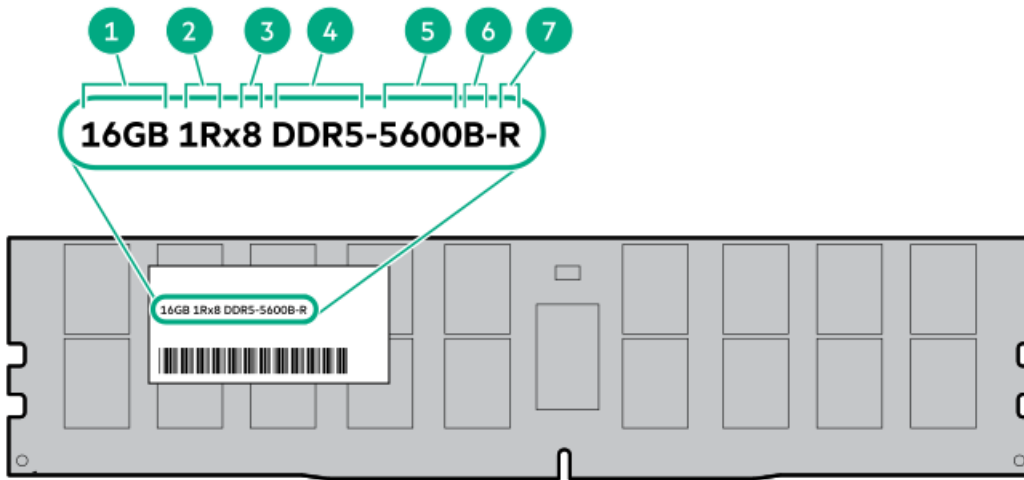

Item	Description	Example
1	Capacity ¹	16 GB 32 GB 64 GB 128 GB 256 GB
2	Rank	1R—Single rank 2R—Dual rank 4R—Quad rank 8R—Octal rank
3	Data width on DRAM	x4—4-bit x8—8-bit
4	Memory generation	PC5—DDR5
5	Maximum memory speed ¹	4800 MT/s 5600 MT/s
6	CAS latency	B—42-42-42 B—50-42-42 (for 128 GB and 256 GB capacities)
7	DIMM type	E—UDIMM (unbuffered with ECC) R—RDIMM (registered)

¹ The maximum memory speed and capacity is a function of the memory type, memory configuration, and processor model.

DIMM slot numbering

The arrow points to the front of the server.



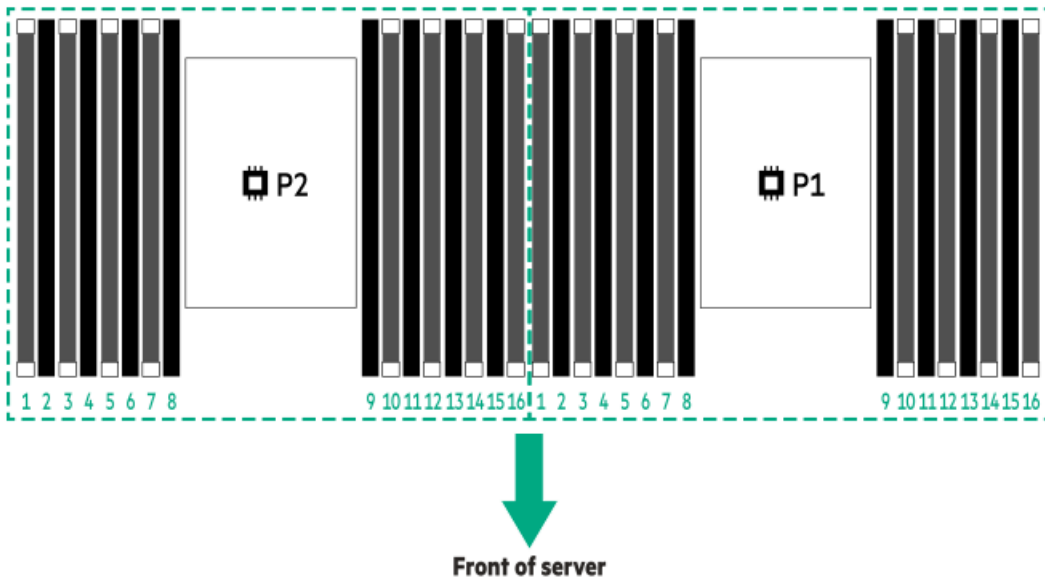

Heatsink and processor socket components

A standard heatsink is shown. Your heatsink might look different.

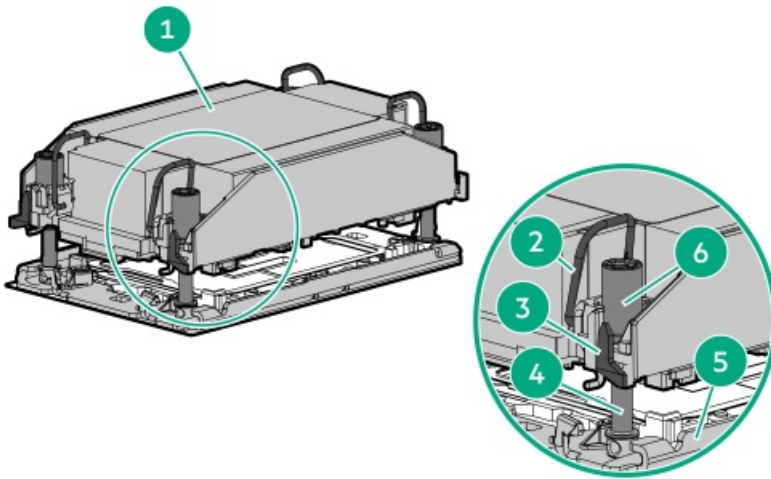

Item	Description
1	Processor-heatsink module *
2	Anti-tilt wires
3	Processor carrier release tabs
4	Bolster plate guide posts
5	Bolster plate
6	Heatsink screws

* This module consists of the heatsink attached to the processor that is already secured in its carrier.

Internal components



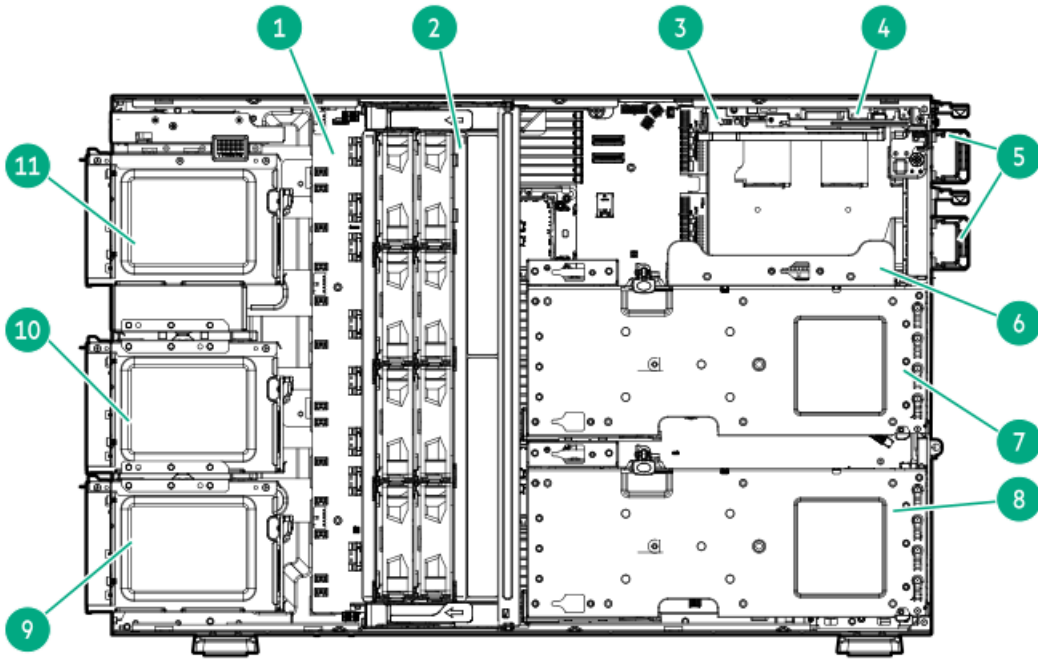

Item	Description
1	System board
2	Fan cage
3	Energy pack
4	NS204i-u device
5	Flexible Slot power supply (2)
6	Tertiary riser
7	Secondary riser cage
8	Primary riser cage
9	Box 3
10	Box 2
11	Box 1

Riser board components

The PCIe5 4 x8 and PCIe5 2 x16 riser options can be installed in either the primary or the secondary riser location. This server supports mixed PCIe5 4 x8 + 2 x16 risers.

PCIe5 4 x8 riser components



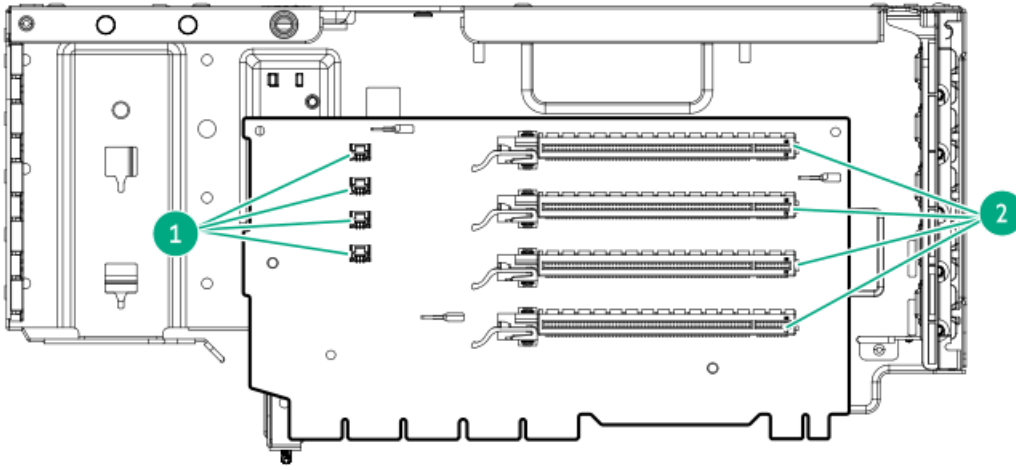

Item Description

- 1 Storage controller backup power connectors
- 2 PCIe 5 x16 (8, 4, 1) slots

PCIe 2 x16 riser components

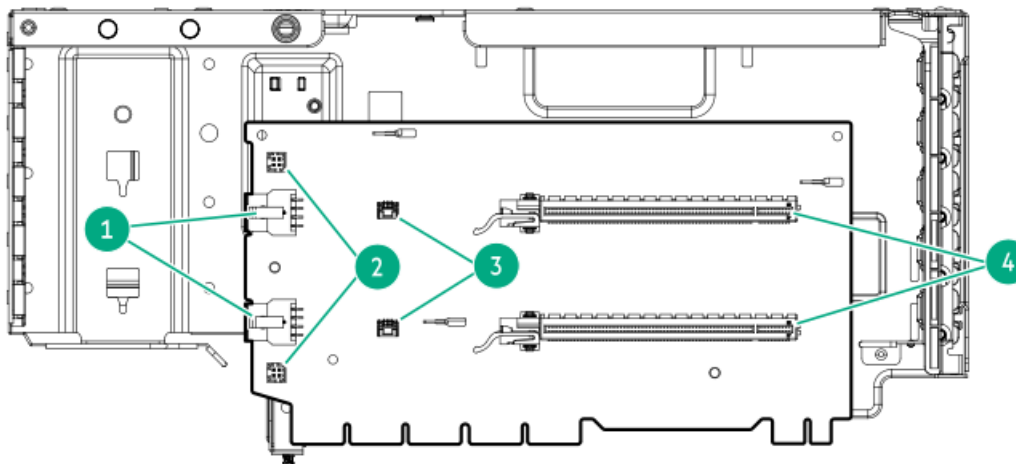

Item Description

- 1 GPU auxiliary power connectors
- 2 GPU sideband connectors
- 3 Storage controller backup power connectors
- 4 PCIe 5 x16 (16, 8, 4, 1) slots

Tertiary riser components



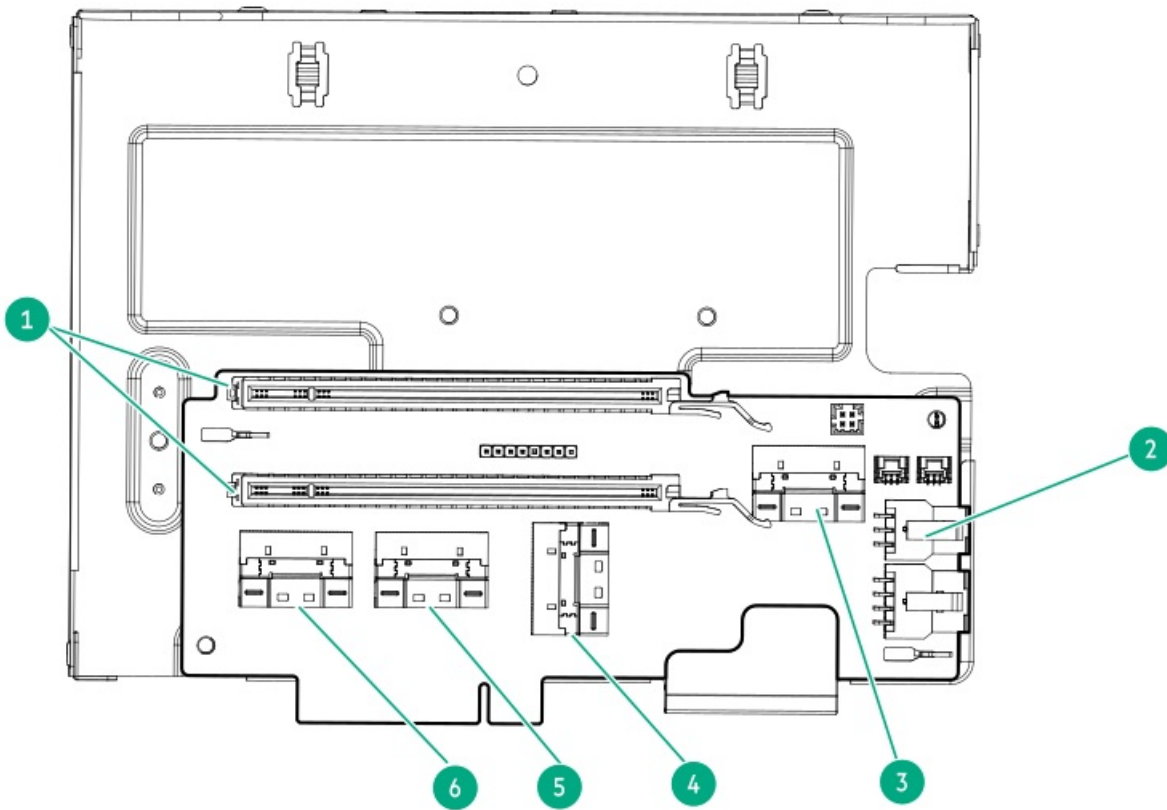

Item Description

- | | |
|---|----------------------------------|
| 1 | PCIe5 x16 (8, 4, 1) slots |
| 2 | RDX power connector |
| 3 | PCIe SlimSAS port 2 ¹ |
| 4 | PCIe SlimSAS port 4 ¹ |
| 5 | PCIe SlimSAS port 3 |
| 6 | PCIe SlimSAS port 1 |

¹ Not for use in this server.

Riser slot numbering

- Primary and secondary riser slots are PCIe5 x16 (16, 8, 4, 1) or PCIe5 x16 (8, 4, 1) .
- Tertiary riser slots are PCIe5 x16 (8, 4, 1).

All riser slots are rated for a maximum power draw of 75 W each without an auxiliary power cable.

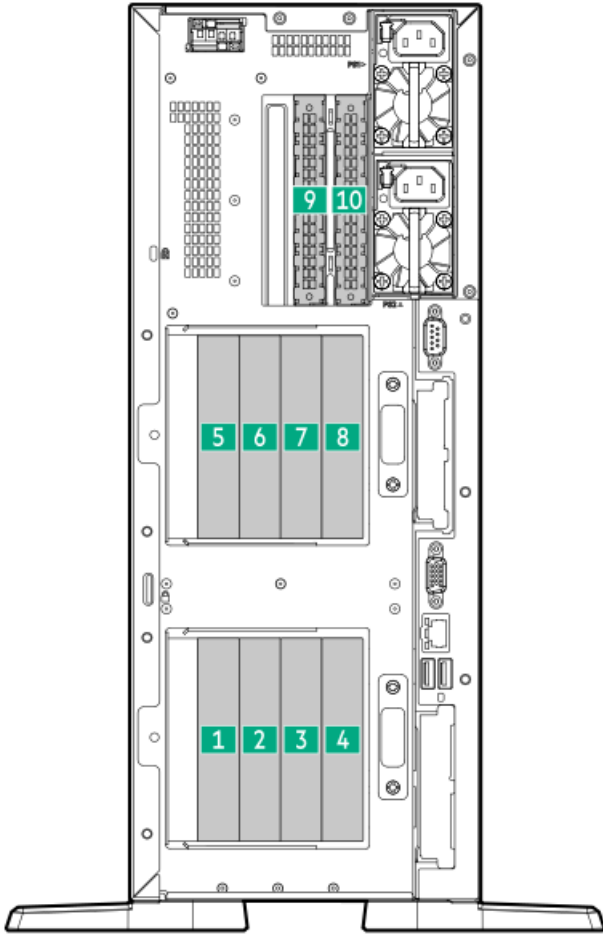

Slot number	Location	Supported form factors
1	Primary riser cage	• Full-height, full-length
2 ¹		• Full-height, half-length
3		• Half-height, half-length (low-profile)
4 ¹		
5	Secondary riser cage	
6 ¹		
7		
8 ¹		
9	Tertiary riser	Half-height, half-length (low-profile)
10		

¹ This slot on the PCIe5 2 x16 riser board supports double-width accelerators.

HPE Basic Drive LED definitions

The HPE Basic drive carrier has the following LEDs:

- Amber/blue LED—Managed by the drive backplane in conjunction with the storage controller and is used to indicate drive status.



- Green LED—Managed by the drive itself and indicates the drive activity.

LFF low-profile drive carrier

The LFF low-profile drive carrier supports hot-plug SAS and SATA drives.

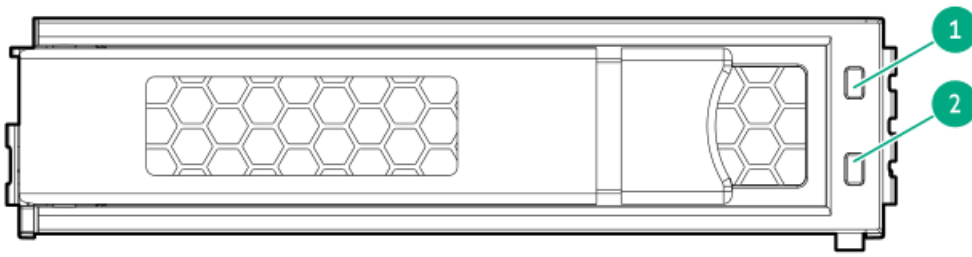

SFF basic drive carrier

The SFF basic drive carrier supports hot-plug SAS, SATA, and U.3 PCIe4 NVMe drives.

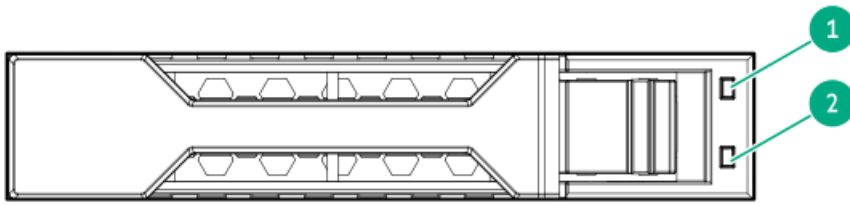

Item	LED	State	Definition
1	Fault/Locate	Solid amber	This drive has failed, is unsupported, or is invalid.
		Solid blue	The drive is operating normally and being identified by a management application.
		Flashing amber/blue (1 flash per second)	The drive has failed, or a predictive failure alert has been received for this drive. The drive has also been identified by a management application.
		Flashing amber (1 flash per second)	A predictive failure alert has been received for this drive. Replace the drive as soon as possible.
		Off	The drive is operating normally and not being identified by a management application.
2	Online/Activity	Solid green	The drive is online and has no activity.
		Flashing green (1 flash per second)	The drive is doing one of the following: <ul style="list-style-type: none"> Rebuilding or performing a RAID Performing a stripe size migration Performing a capacity expansion Performing a logical drive extension Erasing Spare part activation
		Flashing green (4 flashes per second)	The drive is operating normally and has activity.
		Off	The drive is not configured by a RAID controller or is a spare drive.

EDSFF SSD LED definitions

This server supports hot-plug Enterprise and Data Center Standard Form Factor (EDSFF) drives. Specifically, E3.S PCIe5 NVMe SSDs. The EDSFF drive carrier has two LEDs:

- Amber/blue LED—Managed by the drive backplane in conjunction with the storage controller and is used to indicate drive status.
- Green LED—Managed by the drive itself and indicates the drive activity.



Item	LED	State	Definition
1	Fault/Locate	Solid amber	This drive has failed, is unsupported, or is invalid.
		Solid blue	The drive is operating normally and being identified by a management application.
		Flashing amber/blue (1 flash per second)	The drive has failed, or a predictive failure alert has been received for this drive. The drive has also been identified by a management application.
		Flashing amber (1 flash per second)	A predictive failure alert has been received for this drive. Replace the drive as soon as possible.
		Off	The drive is operating normally and not being identified by a management application.
2	Online/Activity	Solid green	The drive is online and has no activity.
		Flashing green (4 flashes per second)	The drive is operating normally and has activity.
		Off	No power present

Drive bay numbering

CAUTION:

When a server is purchased without any drive installed, some drive bays might be empty while other drive bays might be populated with drive blanks. To maintain proper system cooling, do not operate the server without a drive or a drive blank installed.

Subtopics

[LFF drive bay numbering](#)

[SFF drive bay numbering](#)

[Mixed drive bay numbering](#)

[E3.S drive bay numbering](#)

LFF drive bay numbering

LFF drive box uses the 4 LFF 12G x1 SAS / SATA UBM3 drive backplane.

For more information on the drive backplane description, see [Drive backplane naming](#).

Tower orientation

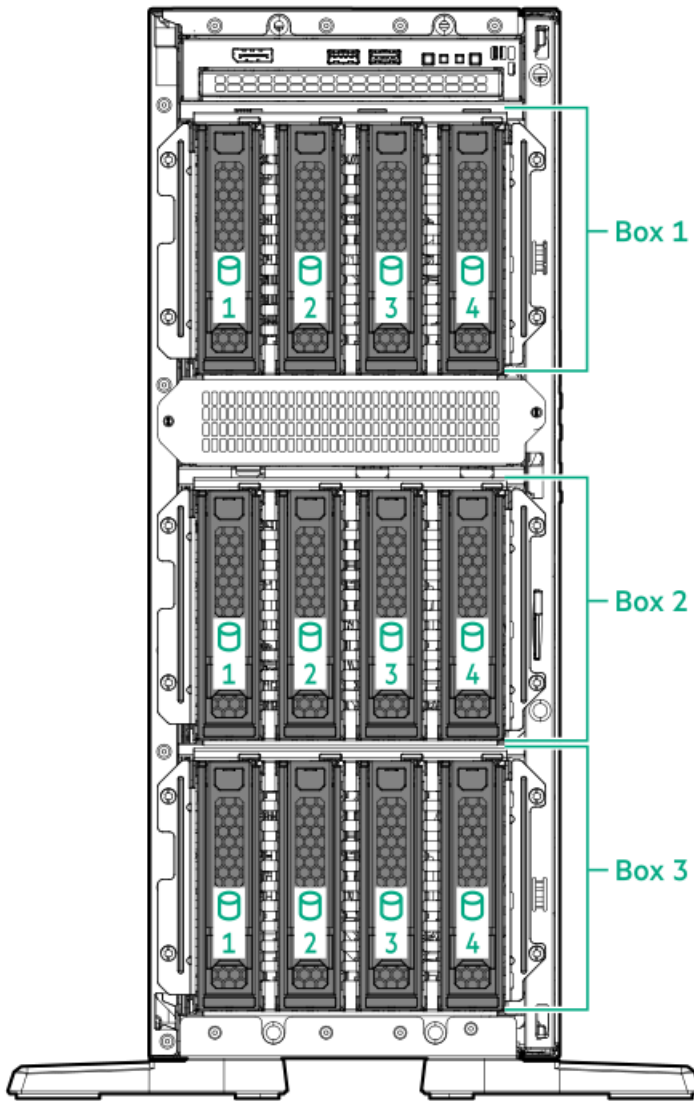

Rack orientation

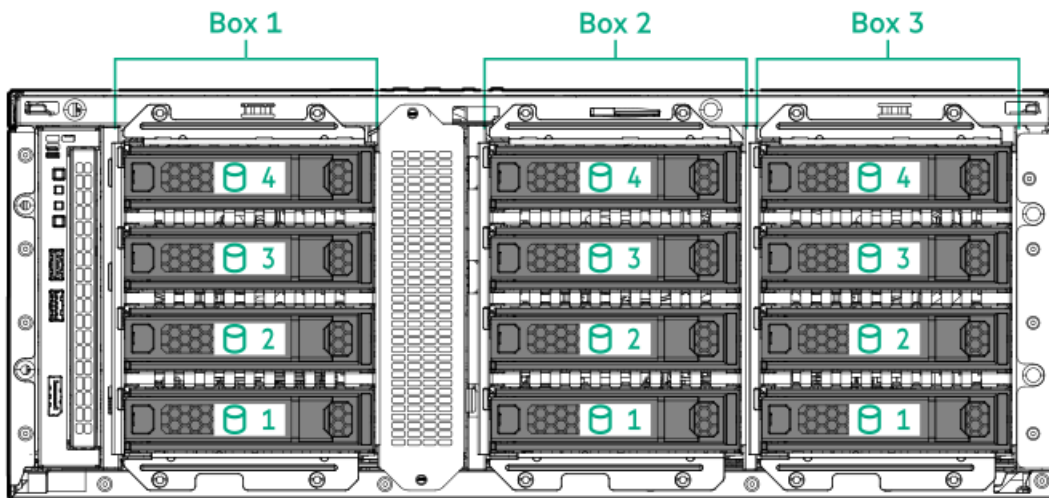

SFF drive bay numbering



The following drive backplane options are supported in SFF drive configurations:

- 8 SFF 24G x1 U.3 NVMe / SAS UBM3 BC
- 8 SFF 24G x1 U.3 NVMe / SAS UBM6 BC
- 8 SFF 24G x4 U.3 NVMe UBM3 BC
- 8 SFF 24G x4 U.3 NVMe UBM6 BC

For more information on the drive backplane description, see [Drive backplane naming convention](#).

Tower orientation

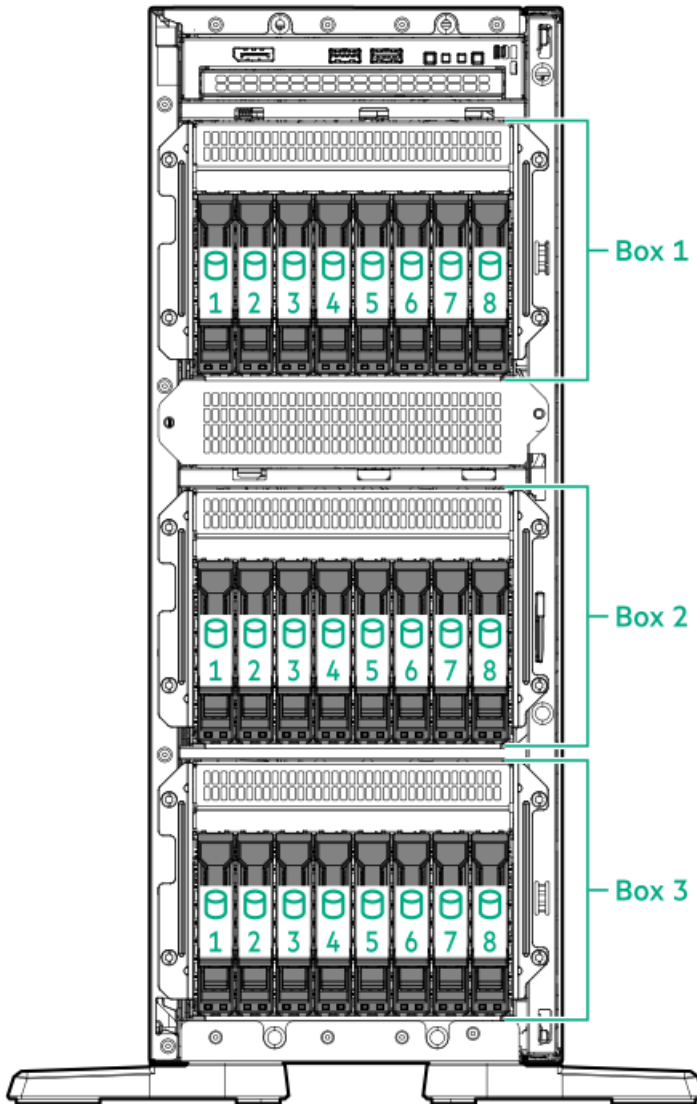

Rack orientation



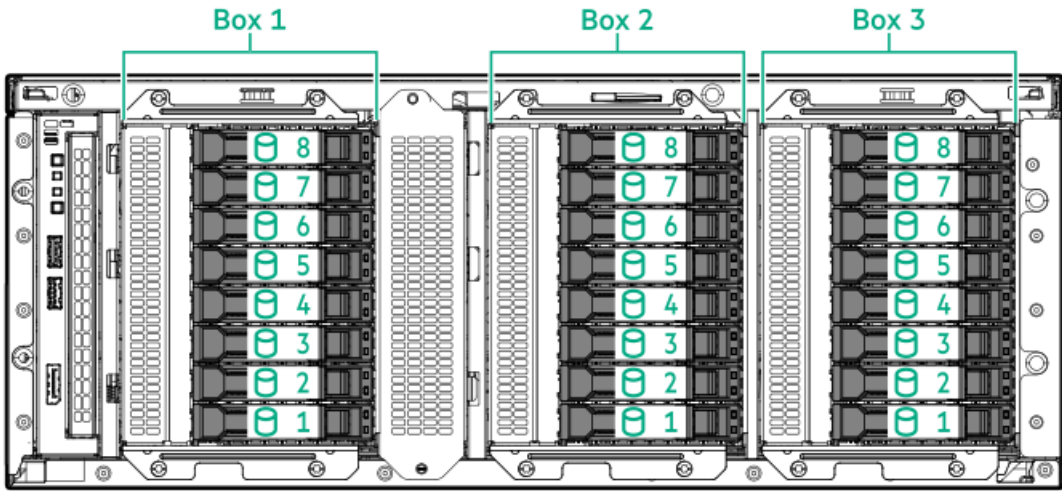

Mixed drive bay numbering

This server supports the following mixed hot-plug drive configurations.

4 LFF + 8 SFF

Tower orientation



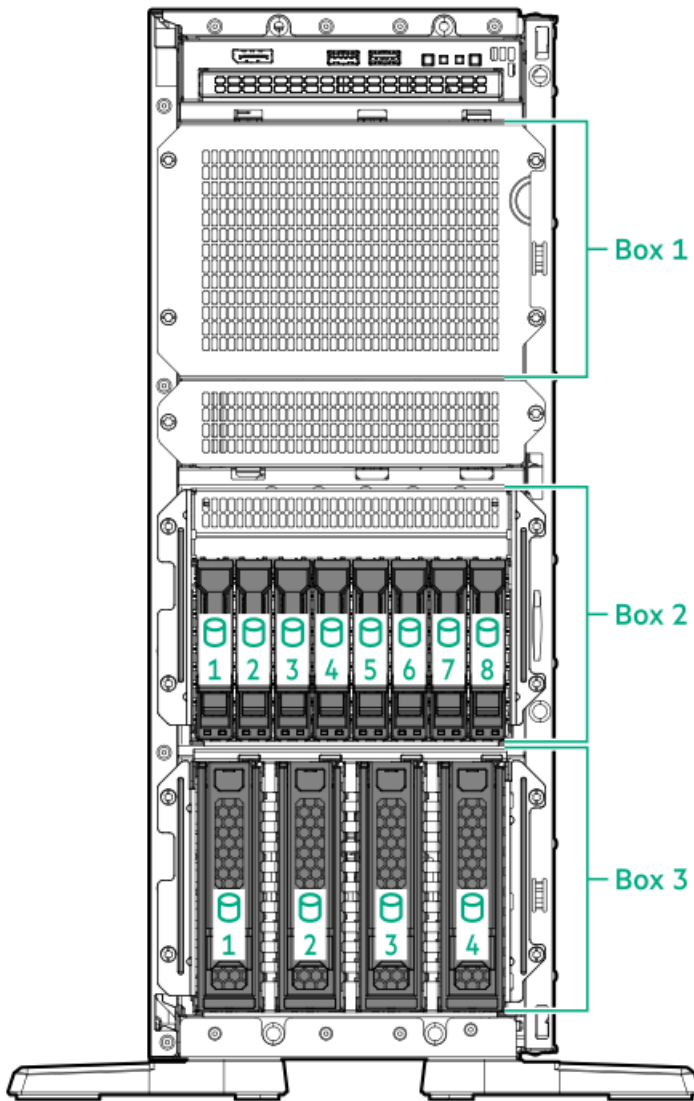

Rack orientation

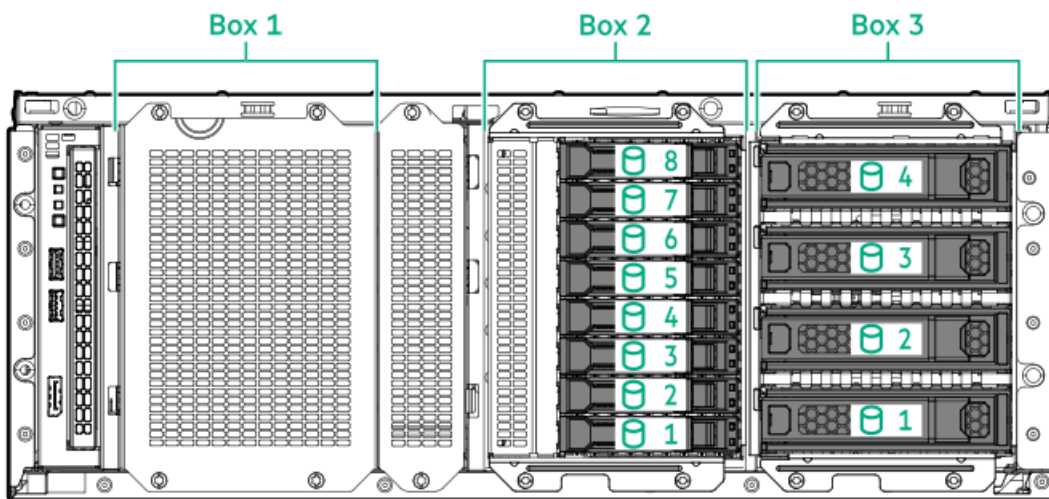

4 LFF + 16 SFF

Tower orientation



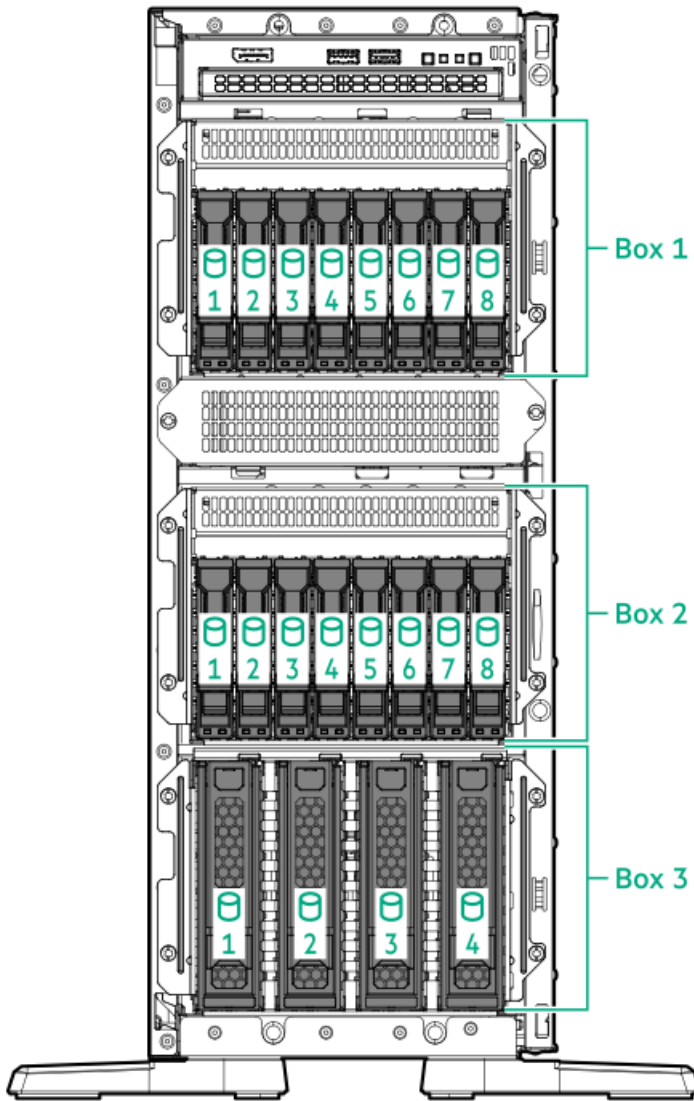

Rack orientation

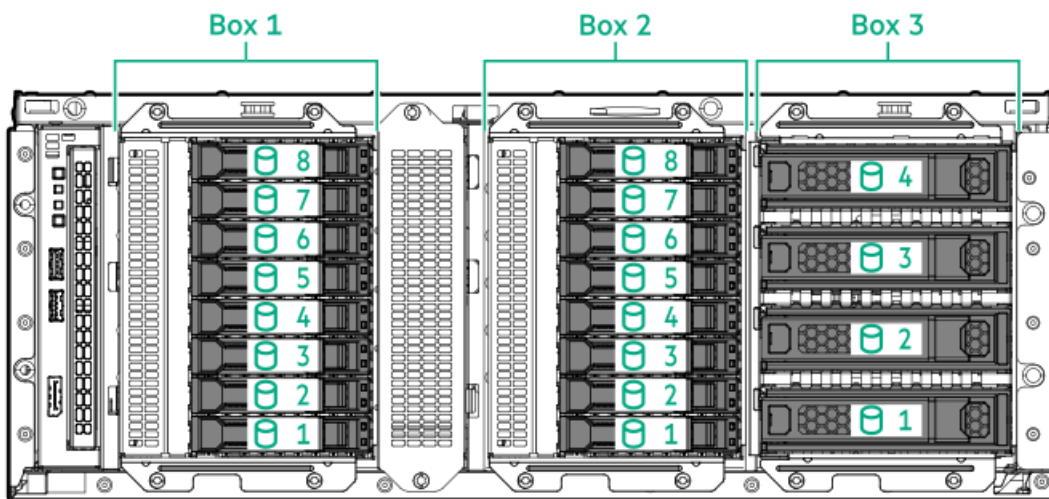

E3.S drive bay numbering



The following drive backplanes are supported in the E3.S drive box by default in the Box 3:

- 12 E3.S 32G x4 NVMe UMB5 EC
- 12 E3.S 32G x4 NVMe UMB7 EC

For more information on the drive backplane description, see [Drive backplane naming](#).

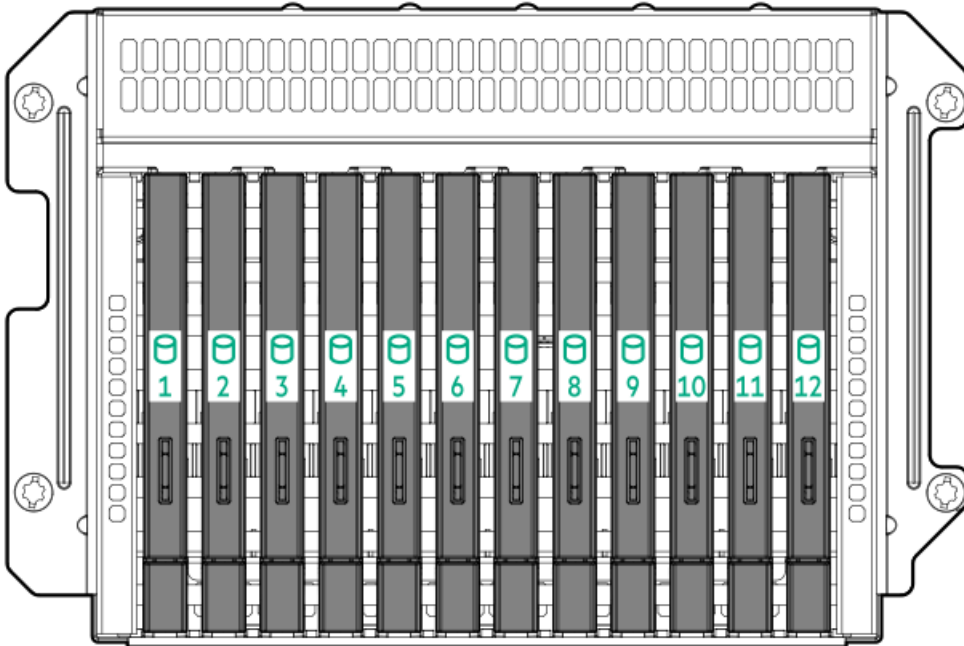

Drive backplane naming

This topic explains the features represented in the drive backplane naming. This naming convention was adopted starting in the HPE Gen11 server release. Your server might not support all the features listed in this topic. For server-specific support information, see the server guides:

- Drive backplane support, see [Drive bay numbering](#).
- Drive backplane cabling, see [Storage cabling](#).



Item	Description	Values
1	Drive bay count	Number of drive bays supported by the backplane.
2	Drive form factor	LFF—Large Form Factor SFF—Small Form Factor E3.S—Enterprise and Datacenter Standard Form Factor (EDSFF)
3	Maximum link rate per lane (GT/s)	12G 16G 24G 32G
4	Port link width and interface	x1 NVMe/SAS—U.3 NVMe, SAS, or SATA ¹ x4 NVMe/SAS—U.3 NVMe, SAS, or SATA ² x4 NVMe—U.2 NVMe ³ x4 NVMe—E3.S
5	Universal backplane manager (UBM) options	UBM2—Segregated SAS/SATA UBM3 or UBM6—Converged UBM4 or UBM6—Segregated U.2 NVMe UBM5 or UBM7—EDSFF
6	Drive carrier type	BC—Basic carrier (SFF) LP—Low-profile carrier (LFF) EC1—E3.S carrier

- ¹ Tri-mode controller support for x1 U.3 NVMe, SAS, and SATA drives. System board connection supports SATA drives only.
- ² CPU direct attach or tri-mode controller support for x4 U.3 NVMe, x2 U.3 NVMe, or x1 SAS and SATA drives.
- ³ CPU direct attach or tri-mode controller support for x4 U.2 NVMe drives.

Fan bay numbering

For more information on fan requirements for specific hardware configurations, see [Fan population](#).





Media device screws

There are 12 T-15 Torx screws on the server chassis. These screws are provided as spare screws for installing media devices.

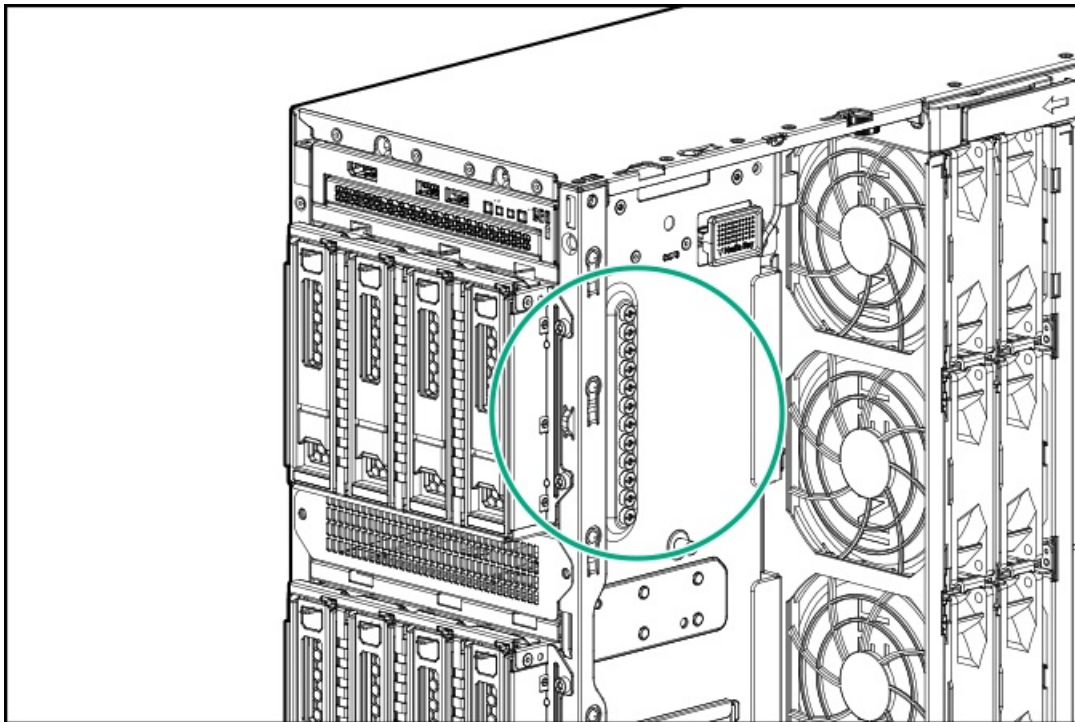

Trusted Platform Module 2.0

The Trusted Platform Module 2.0 (TPM) is a hardware-based system security feature that securely stores artifacts used to authenticate the



platform. These artifacts can include passwords, certificates, and encryption keys.

The TPM 2.0 is embedded on the server system board.

The TPM 2.0 is supported with specific operating system support such as Microsoft Windows Server 2012 R2 and later. For more information about operating system support, see the product QuickSpecs on the Hewlett Packard Enterprise website (<https://www.hpe.com/info/quickspecs>). For more information about Microsoft Windows BitLocker Drive Encryption feature, see the Microsoft website (<https://www.microsoft.com>).

Subtopics

[Trusted Platform Module 2.0 guidelines](#)

[BitLocker recovery key/password retention guidelines](#)

Trusted Platform Module 2.0 guidelines

CAUTION:

- Always observe the TPM guidelines in this section. Failure to follow these guidelines can cause hardware damage or halt data access.
- If you do not follow procedures for modifying the server and suspending or disabling the TPM in the OS, an OS that is using TPM might lock all data access. This includes updating system or option firmware, replacing hardware such as the system board and drives, and modifying TPM OS settings.
- Changing the TPM mode after installing an OS might cause problems, including loss of data.

Hewlett Packard Enterprise SPECIAL REMINDER: Before enabling TPM functionality on this system, you must ensure that your intended use of TPM complies with relevant local laws, regulations and policies, and approvals or licenses must be obtained if applicable.

慧与特别提醒：在您启用系统中的TPM功能前，请务必确认您对TPM的使用遵守当地相关法律、法规及政策，并已事先获得所需的一切批准及许可（如适用），因您未获得相应的操作/使用许可而导致的违规问题，皆由您自行承担全部责任，与慧与无涉。

- When the embedded TPM is enabled, the Trusted Platform Module operates in TPM 2.0 mode.
- Use the UEFI System Utilities to configure the TPM. From the System Utilities screen, select System Configuration > BIOS/Platform Configuration (RBSU) > Server Security > Trusted Platform Module options. For more information, see the UEFI user guide:
<https://www.hpe.com/support/UEFIGen11-UG-en>
- When using the Microsoft Windows BitLocker Drive Encryption feature, always retain the recovery key or password. The recovery key or password is required to enter Recovery Mode after BitLocker detects a possible compromise of system integrity.
- HPE is not liable for blocked data access caused by improper TPM use. For operating instructions, see the documentation for the encryption technology feature provided by the operating system.

BitLocker recovery key/password retention guidelines

The recovery key/password is generated during BitLocker setup, and can be saved and printed after BitLocker is enabled. When using BitLocker, always retain the recovery key/password. The recovery key/password is required to enter Recovery Mode after BitLocker detects a possible compromise of system integrity.

To help ensure maximum security, observe the following guidelines when retaining the recovery key/password:

- Always store the recovery key/password in multiple locations.
- Always store copies of the recovery key/password away from the server.

- Do not save the recovery key/password on an encrypted drive.

HPE NS204i-u Boot Device components

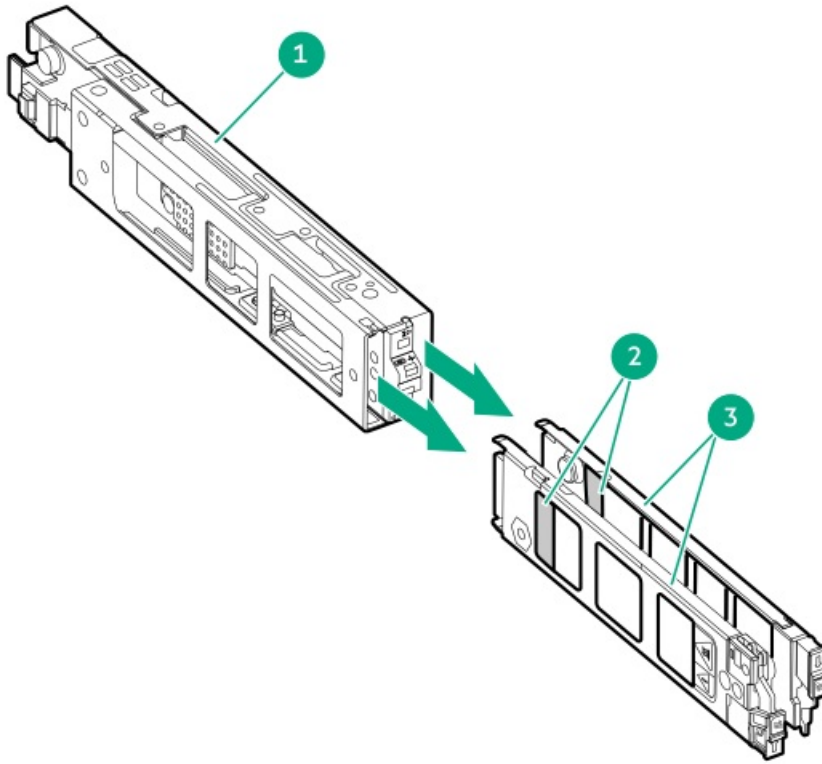

Item	Description
1	Boot device cage
2	M.2 slots
3	Boot device carriers

HPE NS204i-u Boot Device LED definitions

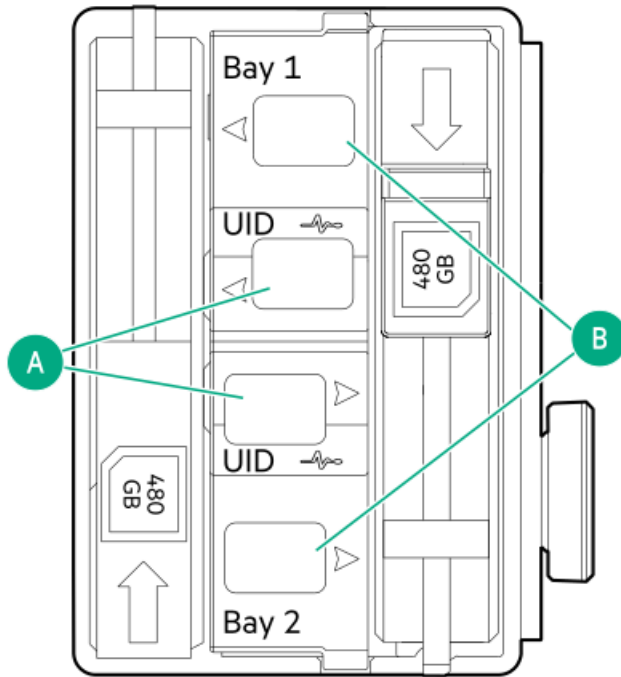

NOTE: The bay number can be found on the SSD carrier handle.

Item	LED	Status	Definition
A	Fault or Locate	Solid amber	Drive has failed, unsupported, or invalid.
		Solid blue	Drive is operating normally.
		Flashing amber or blue (one flash per second)	Drive has failed, or a predictive failure alert is received for the drive.
		Flashing amber (one flash per second)	Drive predictive failure alert is received. Replace the drive as soon as possible.
		Off	Drive is operating normally and is not identified by any application.
B	Online/Activity	Solid green	Drive is online and has no activity.
		Flashing green (one flash per second)	Drive is doing one of the following: <ul style="list-style-type: none"> Rebuilding or performing a RAID Erasing
		Flashing green (4 flashes per second)	Drive is operating normally and has activity.
		Off	Drive is not configured by a RAID controller.

Setup

This chapter describes general operational requirements and safety reminders, as well as the initial setup procedure for the server.

Subtopics

[Initial system installation](#)

[Removing the shipping brackets](#)

Operational requirements

Rack warnings and cautions

Server warnings and cautions

Electrostatic discharge

Initial system installation

Depending on your technical expertise and the complexity of the product, for the initial system installation, select one of the following options:

- [Ordering the HPE Installation Service](#)
- [Setting up the server](#)

Subtopics

[HPE Installation Service](#)

[Intel VROC support](#)

[Setting up the server](#)

HPE Installation Service

HPE Installation Service provides basic installation of Hewlett Packard Enterprise branded equipment, software products, as well as HPE-supported products from other vendors that are sold by HPE or by HPE authorized resellers. The Installation Service is part of a suite of HPE deployment services that are designed to give users the peace of mind that comes from knowing that their HPE and HPE-supported products have been installed by an HPE specialist.

The HPE Installation Service provides the following benefits:

- Installation by an HPE authorized technical specialist.
- Verification prior to installation that all service prerequisites are met.
- Delivery of the service at a mutually scheduled time convenient to your organization.
- Allows your IT resources to stay focused on their core tasks and priorities.
- Full coverage during the warranty period for products that require installation by an HPE authorized technical specialist.

For more information on the features, limitations, provisions, and ordering information of the HPE Installation Service, see this Hewlett Packard Enterprise website:

<https://www.hpe.com/support/installation-service>

Intel VROC support

Intel Virtual RAID on CPU (Intel VROC) provides enterprise-level hybrid RAID support. Note the following information:

- Intel VROC provides RAID support for direct attached SATA and NVMe SSDs.
- The Intel VROC driver is required. For the OS-specific driver download, see the following page:

https://support.hpe.com/hpesc/public/docDisplay?docId=sd00002239en_us&page=GUID-249FA246-0985-4598-8D7E-

- Intel VROC requires the server boot mode to be set to UEFI Mode.
- Intel VROC RAID support is disabled by default. In the pre-OS environment, use UEFI System Utilities to enable Intel VROC and create a VROC RAID volume. These tasks are not supported in Intelligent Provisioning.
- The VROC RAID volume must use drives of the same interface and form factor.
- Intel VROC supports RAID management through the following tools:
 - Non-OS specific: UEFI System Utilities
 - Windows: Intel VROC GUI, Intel VROC CLI
 - Linux: `mdadm` CLI

For more information on Intel VROC features and configuration, see [Configuring storage controllers](#).

Setting up the server

Prerequisites

- As a best practice, Hewlett Packard Enterprise recommends installing the latest firmware, drivers, and system software before using the server for the first time. You have these options:
 - HPE GreenLake for Compute Ops Management is an advanced software-as-a-service platform that securely streamlines operations from edge-to-cloud and automates key life cycle tasks through a unified single browser-based interface. For more information on using HPE GreenLake for Compute Ops Management, see <https://www.hpe.com/info/com-docs>.
 - Use the Firmware Update option in Intelligent Provisioning—Intelligent Provisioning is a server deployment tool embedded in HPE ProLiant servers. To access Intelligent Provisioning, during the server boot process, press **F10**. For more information, see the Intelligent Provisioning user guide at <https://www.hpe.com/info/intelligentprovisioning/docs>.
 - Download the Service Pack for ProLiant (SPP)—SPP is a comprehensive system software and firmware update solution that is delivered as a single ISO image. This solution uses Smart Update Manager (SUM) as the deployment tool.
 - The preferred method for downloading an SPP is by creating an SPP custom download at <https://www.hpe.com/servers/spp/custom>.
This option reduces the size of the SPP by excluding firmware and drivers for OS and server models that are not needed.
 - The SPP is also available for download from the SPP download page at <https://www.hpe.com/servers/spp/download>.
- Verify that your OS or virtualization software is supported:
<https://www.hpe.com/support/Servers-Certification-Matrices>
- This server supports type-o and type-p storage controller options. For storage configuration, use either SATA AHCI (default) or Intel Virtual RAID on CPU (Intel VROC). If you plan to use Intel VROC, [review this important information before setting up the server](#).
- Read the [Operational requirements](#) for the server.
- Read the safety and compliance information:
<https://www.hpe.com/support/safety-compliance-enterpriseproducts>
- Take note of the iLO hostname and default login credentials on the [serial number/iLO information pull tab](#).

Procedure

1. Unbox the server and verify the contents:
 - Server
 - Power cord

- Rack-mounting hardware (optional)
- Printed setup documentation

The server does not ship with OS media. All system software and firmware is preloaded on the server.

2. (Optional) Install the hardware options.

3. Select the server orientation:

- Tower orientation: Connect the peripheral cables and power cord.
- Rack orientation:
 - If the server was shipped with the tower-to-rack conversion kit, install the tower-to-rack conversion kit.
 - If the server was shipped in a rack, remove the shipping brackets.

4. Decide how to manage the server:

- Locally: Use a KVM switch or connect a keyboard, monitor, and mouse.
- Remotely: Connect to the iLO web interface and run a remote console:

a. Verify the following:

- iLO is licensed to use the remote console feature.
If iLO is not licensed, visit the HPE website:

<https://www.hpe.com/info/ilo>

- The iLO management port is connected to a secure network.

b. Using a browser, navigate to the iLO web interface, and then log in.

```
https://<iLO hostname or IP address>
```

Note the following:

- If a DHCP server assigns the IP address, the IP address appears on the boot screen.
- If a static IP address is assigned, use that IP address.
- c. Enter the iLO login name and password, and then click Log In.
- d. In the navigation tree, click the Remote Console & Media link, and then launch a remote console.

5. Press the Power On/Standby button.

For remote management, use the iLO virtual power button.

6. Configure the initial server setup.

7. Set up the storage.

8. Deploy an OS or virtualization software.

9. After the OS is installed, update the drivers.

10. Register the server.

Removing the shipping brackets

Prerequisites

Before you perform this procedure, make sure that you have a T-25 Torx screwdriver available.

About this task



A server shipped in a rack is secured by shipping brackets. To allow the server tray to be extended out of the rack during normal server operation, remove these shipping brackets.

Procedure

1. Remove the screws securing the shipping bracket.
2. Remove the shipping bracket from the front rack column.

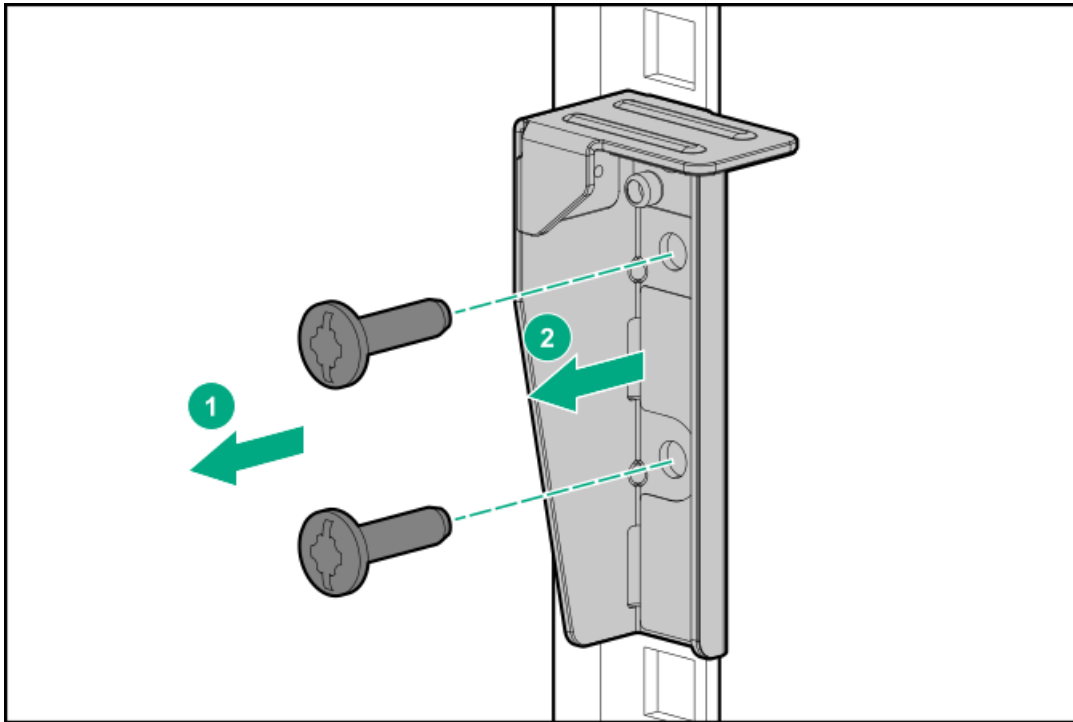

3. Repeat steps 1–2 to remove the bracket from the other opposite rack column.

Retain the shipping brackets and screws in case there is a need to ship or transport the rack-mounted server at a later date.

Operational requirements

When preparing the site and planning the installation for the HPE ProLiant ML350 Gen11 Server, be sure to observe the following general operational requirements:

- [Space and airflow requirements](#)
- [Temperature requirements](#)
- [Power requirements](#)
- [Electrical grounding requirements](#)

For server-specific environmental requirements, see [Environmental specifications](#).

Subtopics

[Space and airflow requirements](#)

[Temperature requirements](#)

[Power requirements](#)

[Electrical grounding requirements](#)

Space and airflow requirements

To allow for servicing and adequate airflow, observe the following space and airflow requirements when installing the server in an indoor commercial rack:

- 63.50 cm (25.00 in) in front of the rack
- 76.20 cm (30.00 in) behind the rack
- 121.90 cm (48.00 in) from the back of the rack to the back of another rack or row of racks

Observe the following additional airflow requirements:

- Servers draw in cool air through the front door and expel warm air through the rear door. Therefore, the front and rear rack doors must be adequately ventilated to allow ambient room air to enter the cabinet, and the rear door must be adequately ventilated to allow the warm air to escape from the cabinet.
- To prevent improper cooling and damage to the equipment, do not block the ventilation openings.
- When the vertical space in the rack is not filled by a server or rack component, the gaps between the components cause changes in airflow through the rack and across the servers. Cover all gaps with blanking panels to maintain proper airflow. Using a rack without blanking panels results in improper cooling which can lead to thermal damage.
- If a third-party rack is used, observe the following additional requirements to ensure adequate airflow and prevent damage to the equipment:
 - Front and rear doors—If the 42U rack includes closing front and rear doors, you must allow 5,350 sq cm (830 sq in) of holes evenly distributed from top to bottom to permit adequate airflow (equivalent to the required 64 percent open area for ventilation).
 - Side—The clearance between the installed rack component and the side panels of the rack must be a minimum of 7.00 cm (2.75 in).

Temperature requirements

To ensure continued safe and reliable equipment operation, install or position the system in a well-ventilated, climate-controlled environment.

The maximum recommended ambient operating temperature (TMRA) for most server products is 35°C (95°F). The temperature in the room where the rack is located must not exceed 35°C (95°F).



CAUTION: To reduce the risk of damage to the equipment when installing third-party options:

- Do not permit optional equipment to impede airflow around the server or to increase the internal rack temperature beyond the maximum allowable limits.
 - Do not exceed the manufacturer's TMRA.
-

Power requirements

Installation of this equipment must comply with local and regional electrical regulations governing the installation of information technology equipment by licensed electricians. This equipment is designed to operate in installations covered by NFPA 70, 1999 Edition (National Electric Code) and NFPA-75, 1992 (code for Protection of Electronic Computer/Data Processing Equipment). For electrical power ratings on options, refer to the product rating label or the user documentation supplied with that option.



WARNING: To reduce the risk of personal injury, fire, or damage to the equipment, do not overload the AC supply branch circuit that provides power to the rack. Consult the electrical authority having jurisdiction over wiring and installation requirements of your facility.



CAUTION: Protect the server from power fluctuations and temporary interruptions with a regulating uninterruptible power supply. This device protects the hardware from damage caused by power surges and voltage spikes and keeps the system in operation during a power failure.

Electrical grounding requirements

The server must be grounded properly for proper operation and safety. In the United States, you must install the equipment in accordance with NFPA 70, National Electric Code Article 250, as well as any local and regional building codes. In Canada, you must install the equipment in accordance with Canadian Standards Association, CSA C22.1, Canadian Electrical Code. In all other countries, you must install the equipment in accordance with any regional or national electrical wiring codes, such as the International Electrotechnical Commission (IEC) Code 364, parts 1 through 7. Furthermore, you must be sure that all power distribution devices used in the installation, such as branch wiring and receptacles, are listed or certified grounding-type devices.

Because of the high ground-leakage currents associated with multiple servers connected to the same power source, Hewlett Packard Enterprise recommends the use of a PDU that is either permanently wired to the building's branch circuit or includes a nondetachable cord that is wired to an industrial-style plug. NEMA locking-style plugs or those complying with IEC 60309 are considered suitable for this purpose. Using common power outlet strips for the server is not recommended.

Rack warnings and cautions



WARNING:

When all components are removed, the server weighs 10.40 kg (22.93 lb). When all components are installed, the server can weigh up to 19 kg (41.89 lb).

Before configuring your rack solution, be sure to check the rack manufacturer weight limits and specifications. Failure to do so can result in physical injury or damage to the equipment and the facility.



WARNING:

The server is heavy. To reduce the risk of personal injury or damage to the equipment, do the following:

- Observe local occupational health and safety requirements and guidelines for manual material handling.
 - Get help to lift and stabilize the product during installation or removal, especially when the product is not fastened to the rails. The server weighs more than 10.40 kg (22.93 lb), so at least two people must lift the server into the rack together. An additional person may be required to help align the server if the server is installed higher than chest level.
 - Use caution when installing the server in or removing the server from the rack.
 - Adequately stabilize the rack before extending a component outside the rack. Extend only one component at a time. A rack may become unstable if more than one component is extended.
 - Do not stack anything on top of rail-mounted component or use it as a work surface when extended from the rack.
-

**WARNING:**

To reduce the risk of personal injury or damage to the equipment, be sure that:

- The rack has anti-tip measures in place. Such measures include floor-bolting, anti-tip feet, ballast, or a combination as specified by the rack manufacturer and applicable codes.
- The leveling jacks (feet) are extended to the floor.
- The full weight of the rack rests on the leveling jacks (feet).
- The stabilizing feet are attached to the rack if it is a single-rack installation.
- The racks are coupled together in multiple rack installations.

**WARNING:**

To reduce the risk of personal injury or equipment damage when unloading a rack:

- At least two people are needed to safely unload the rack from the pallet. An empty 42U rack can weigh as much as 115 kg (253 lb), can stand more than 2.1 m (7 ft) tall, and might become unstable when being moved on its casters.
- Never stand in front of the rack when it is rolling down the ramp from the pallet. Always handle the rack from both sides.

**CAUTION:**

Always plan the rack installation so that the heaviest item is on the bottom of the rack. Install the heaviest item first, and continue to populate the rack from the bottom to the top.

**CAUTION:**

Before installing the server in a rack, be sure to properly scope the limitations of the rack. Before proceeding with the installation, consider the following:

- You must fully understand the static and dynamic load carrying capacity of the rack and be sure that it can accommodate the weight of the server.
- Be sure sufficient clearance exists for cabling, installation and removal of the server, and movement of the rack doors.

Server warnings and cautions

**WARNING:**

To reduce the risk of personal injury, electric shock, or damage to the equipment, disconnect the power cord to remove power from the server. Pressing the Power On/Standby button does not shut off system power completely. Portions of the power supply and some internal circuitry remain active until AC power is removed.



WARNING: To reduce the risk of personal injury from hot surfaces, allow the drives and the internal system components to cool before touching them.

**WARNING:**

To reduce the risk of fire or burns after removing the energy pack:

- Do not disassemble, crush, or puncture the energy pack.
- Do not short external contacts.
- Do not dispose of the energy pack in fire or water.
- Do not expose the energy pack to low air pressure as it might lead to explosion or leakage of flammable liquid or gas.
- Do not expose the energy pack to temperatures higher than 60°C (140°F).

After power is disconnected, battery voltage might still be present for 1s to 160s.

⚠ CAUTION:

Protect the server from power fluctuations and temporary interruptions with a regulating UPS. This device protects the hardware from damage caused by power surges and voltage spikes and keeps the server in operation during a power failure.

⚠ CAUTION:

To prevent damage to electrical components, properly ground the server before beginning any installation, removal, or replacement procedure. Improper grounding can cause [electrostatic discharge](#).

⚠ CAUTION:

To avoid data loss, Hewlett Packard Enterprise recommends that you [back up all server data](#) before installing or removing a hardware option, or performing a server maintenance or troubleshooting procedure.

⚠ CAUTION:

Do not operate the server for long periods with the access panel open or removed. Operating the server in this manner results in improper airflow and improper cooling that can lead to thermal damage.

Electrostatic discharge

Be aware of the precautions you must follow when setting up the system or handling components. A discharge of static electricity from a finger or other conductor may damage system boards or other static-sensitive devices. This type of damage may reduce the life expectancy of the system or component.

To prevent electrostatic damage:

- Avoid hand contact by transporting and storing products in static-safe containers.
- Keep electrostatic-sensitive parts in their containers until they arrive at static-free workstations.
- Place parts on a grounded surface before removing them from their containers.
- Avoid touching pins, leads, or circuitry.
- Always be properly grounded when touching a static-sensitive component or assembly. Use one or more of the following methods when handling or installing electrostatic-sensitive parts:
 - Use a wrist strap connected by a ground cord to a grounded workstation or computer chassis. Wrist straps are flexible straps with a minimum of 1 megohm ± 10 percent resistance in the ground cords. To provide proper ground, wear the strap snug against the skin.
 - Use heel straps, toe straps, or boot straps at standing workstations. Wear the straps on both feet when standing on conductive floors or dissipating floor mats.
 - Use conductive field service tools.
 - Use a portable field service kit with a folding static-dissipating work mat.

If you do not have any of the suggested equipment for proper grounding, have an authorized reseller install the part.

For more information on static electricity or assistance with product installation, contact an authorized reseller.

Operations

This chapter describes the hardware operations carried out prior to and after installing or removing a hardware component, or performing a server maintenance or troubleshooting procedure. Before performing these hardware operations, review the:

- [Rack warnings and cautions](#)
- [Server warnings and cautions](#)

Subtopics

[Power down the server](#)

[Extend the server from the rack](#)

[Remove the server from the rack](#)

[Remove the front bezel](#)

[Position the tower server for hardware configuration](#)

[Remove the access panel](#)

[Remove the fan cage](#)

[Remove the primary riser cage](#)

[Remove the secondary riser cage blank](#)

[Remove the secondary riser cage](#)

[Remove the HPE NS204i-u Boot Device](#)

[Install the primary/secondary riser cage](#)

[Install the fan cage](#)

[Install the access panel](#)

[Position the tower server for operation](#)

[Install the front bezel](#)

[Install the server into the rack](#)

[Power up the server](#)

[Installing the shipping hardware](#)

Power down the server

Before powering down the server for any upgrade or maintenance procedures, [perform a backup of critical server data and programs](#).



IMPORTANT:

When the server is in standby mode, auxiliary power is still being provided to the system.

To power down the server, use one of the following methods:

- Press and release the Power On/Standby button.
This method activates a controlled shutdown of applications and the OS before the server enters standby mode. It can also activate a shutdown behavior governed by an OS configuration or policy.
- Press and hold the Power On/Standby button for more than 4 seconds to force the server to enter standby mode.
This method forces the server to enter standby mode without properly exiting applications and the OS. If an application stops responding, you can use this method to force a shutdown.
- Use a virtual power button selection through iLO 6.
This method initiates a controlled remote shutdown of applications and the OS before the server enters standby mode.

Before proceeding, verify that the server is in standby mode by observing that the system power LED is amber.

Extend the server from the rack

Prerequisites

Before you perform this procedure, review the [Rack warnings and cautions](#).

Procedure

Slide the server tray out of the rack:

1. Loosen the server tray thumbscrews.
2. Grasp the tray notch and slide the server out of the rack.

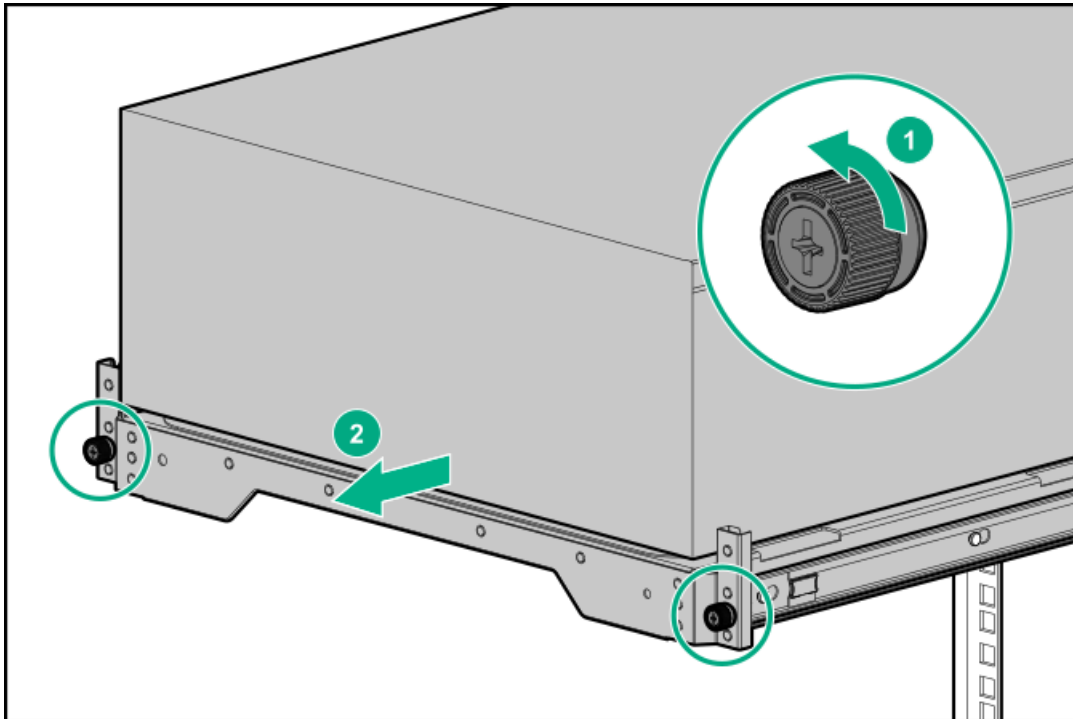

Remove the server from the rack

Prerequisites

- Get help to lift and stabilize the server during removal from the rack. **If the server is installed higher than chest level, an additional two people might be required to help remove the server:** One person to support the server weight, and the other two to slide the server out of the rack.
- Before you perform this procedure, review the:
 - [Rack warnings and cautions](#)
 - [Server warnings and cautions](#)
- A fully populated server is heavy. Hewlett Packard Enterprise recommends removing the external chassis components before removing the server into a rack.
- Before you perform this procedure, make sure that you have a T-15 Torx screwdriver available.

Procedure



1. Power down the server.
2. Remove all power:
 - a. Disconnect each power cord from the power source.
 - b. Disconnect each power cord from the server.
3. Disconnect all peripheral cables from the server.
4. If installed, unlock and remove the security padlock and/or the Kensington security lock.
For more information, see the lock documentation.
5. Slide the server tray out of the rack:
 - a. Loosen the server tray thumbscrews.
 - b. Grasp the tray notch and slide the server out of the rack.

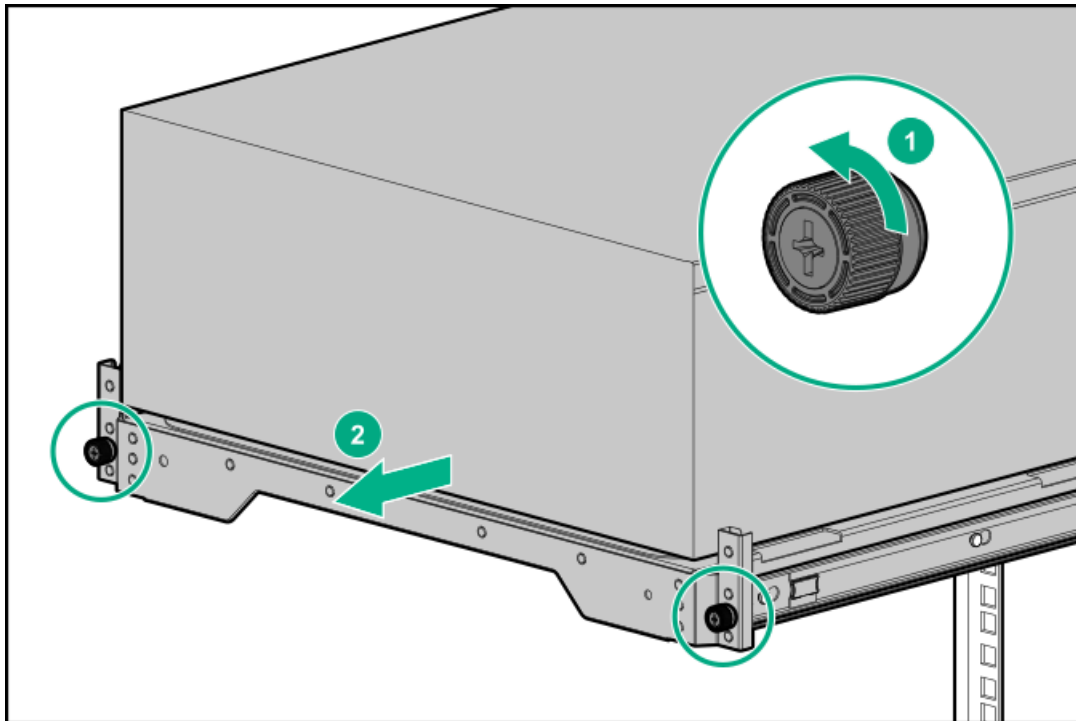

6. Remove the chassis rear bracket screws.

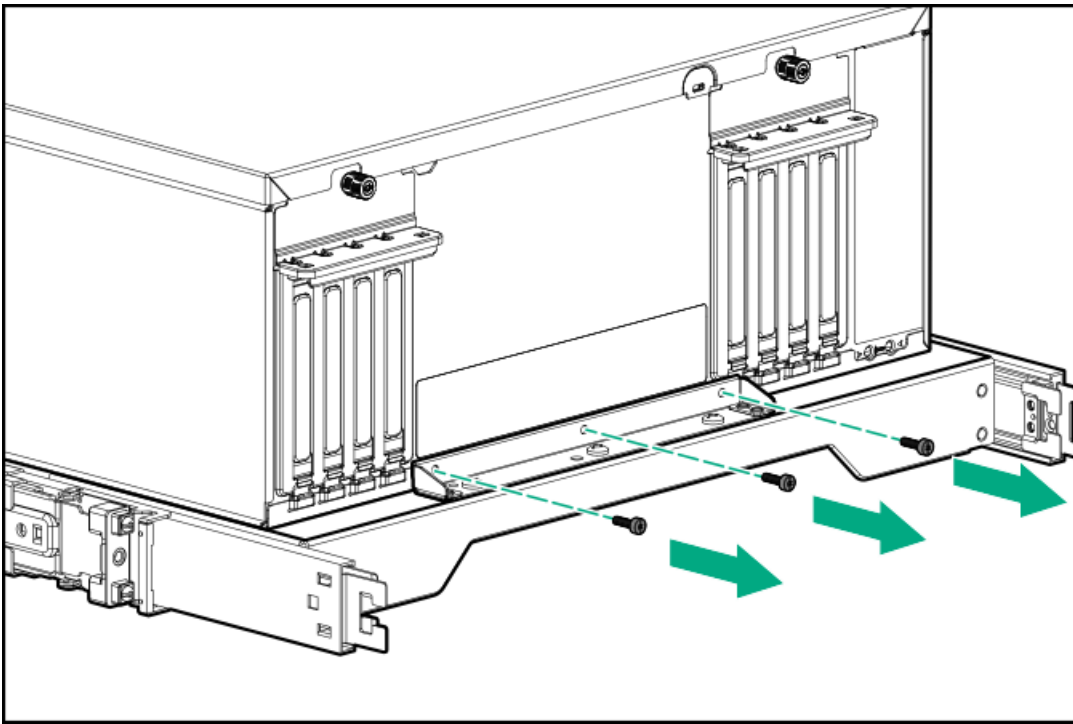

7. Remove the server from the tray.

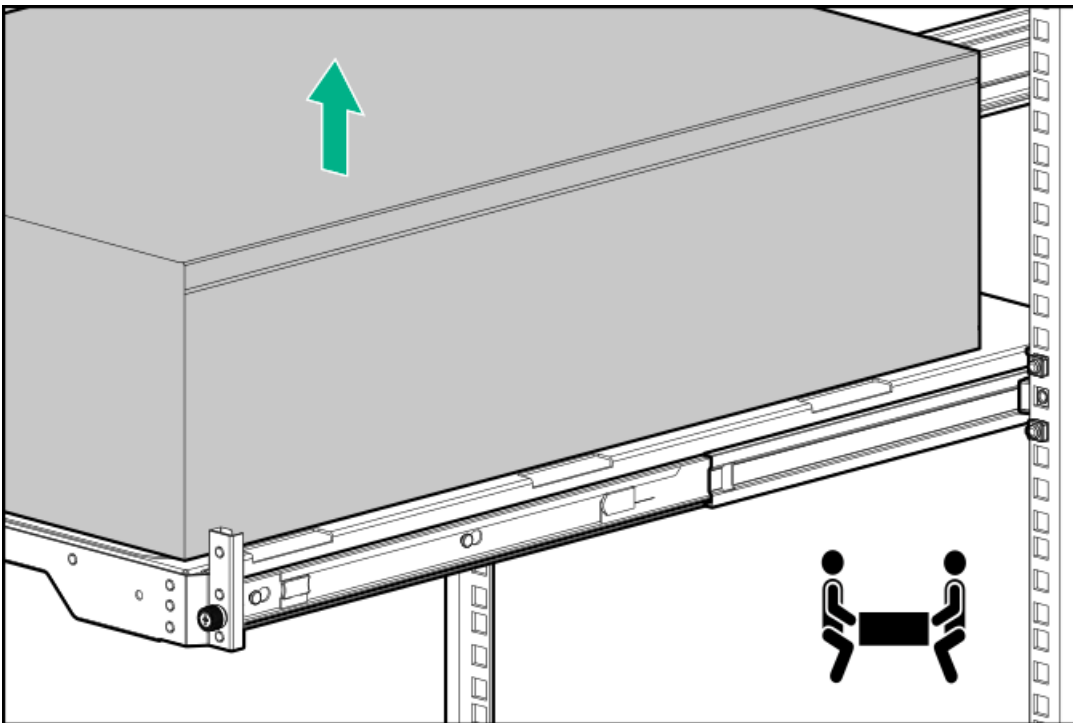

8. Place the server on a flat, level surface with the access panel facing up.

Remove the front bezel

Procedure

1. Unlock the front bezel.
2. Open the front bezel.



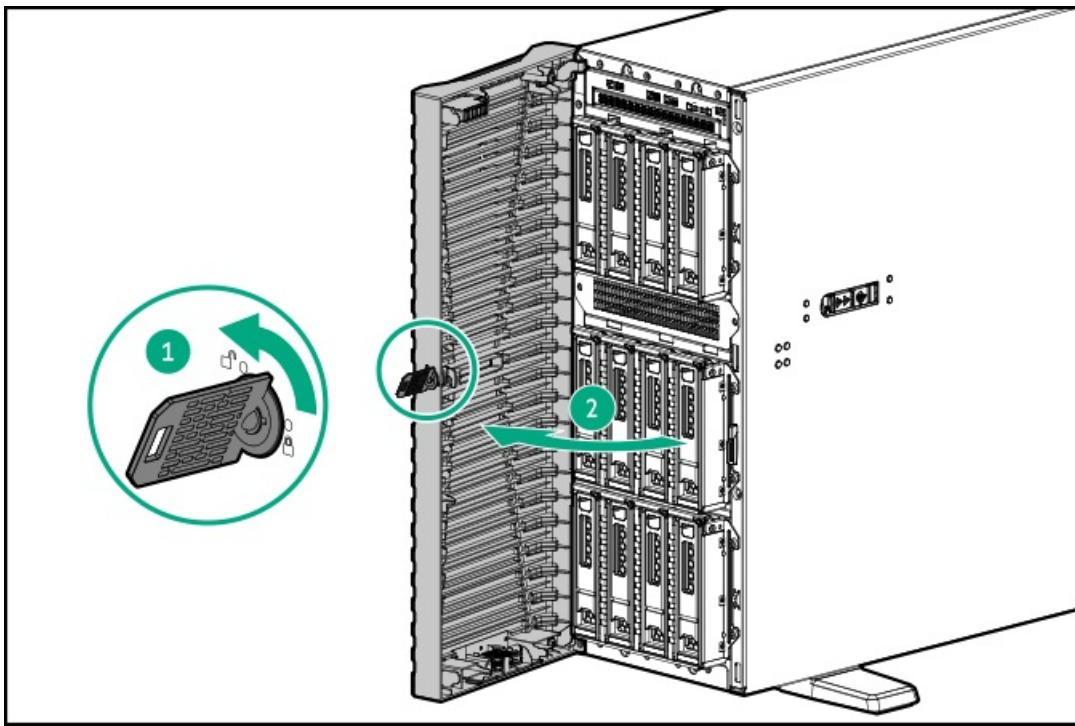

3. Release the bezel hooks from the front panel.

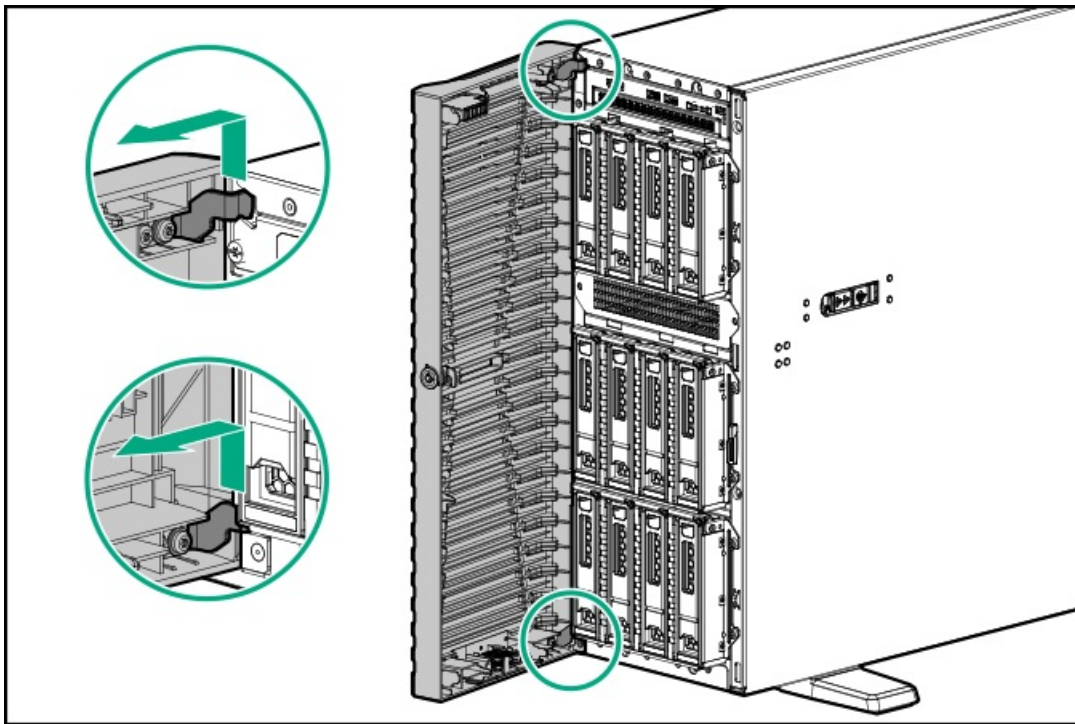

Position the tower server for hardware configuration

Procedure

1. Rotate the chassis feet inward.



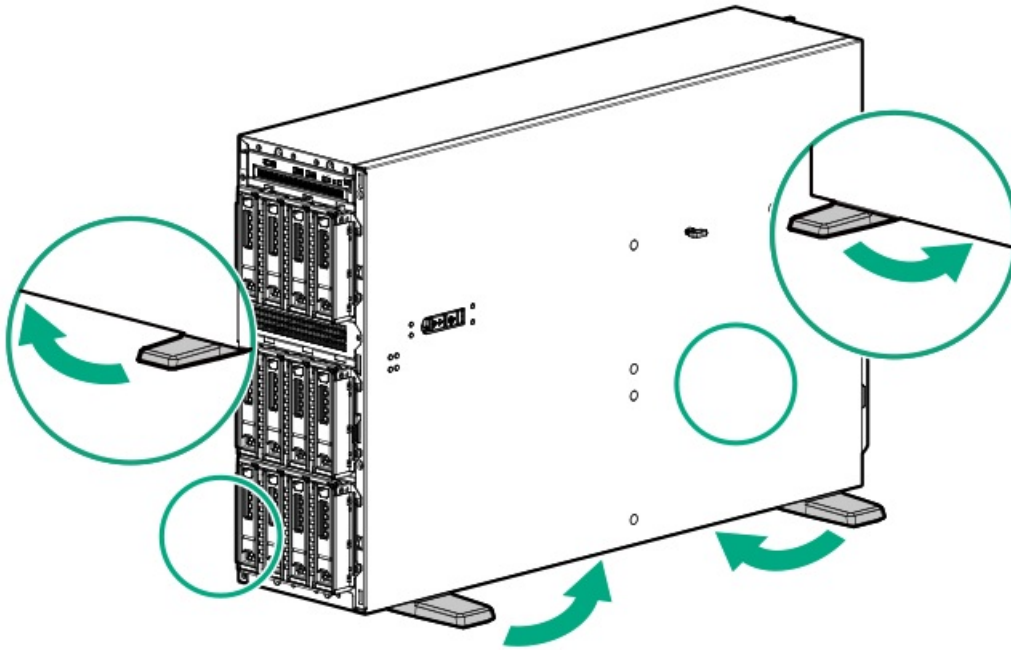

2. Place the server on a flat, level surface with the access panel facing up.

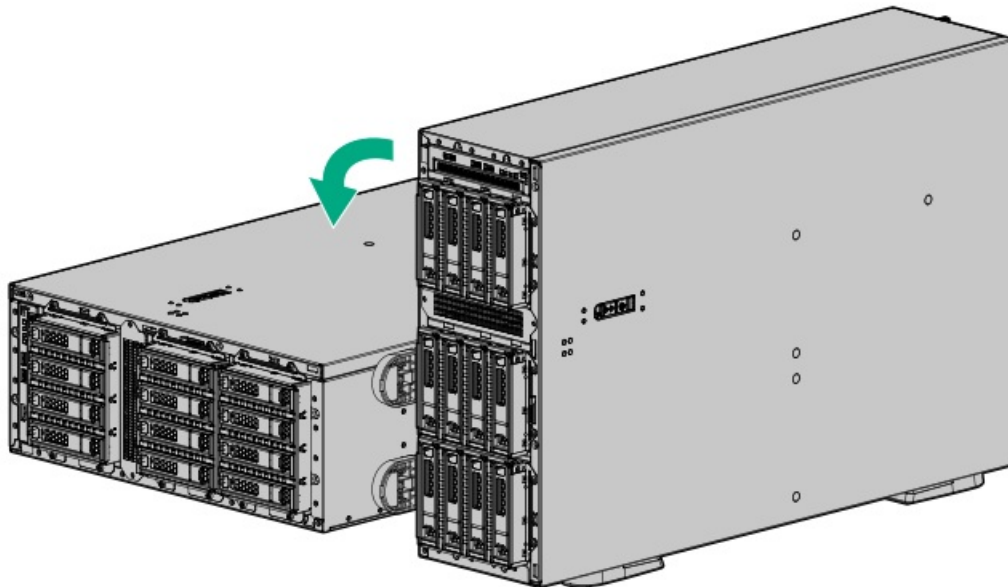

Remove the access panel

Prerequisites

Before you perform this procedure, make sure that you have a T-15 Torx screwdriver available.

About this task



WARNING: To reduce the risk of personal injury from hot surfaces, allow the drives and the internal system components to cool before touching them.

⚠ CAUTION:

To prevent damage to electrical components, properly ground the server before beginning any installation, removal, or replacement procedure. Improper grounding can cause electrostatic discharge.

⚠ CAUTION:

To maintain proper system cooling, do not operate the server for long period with the access panel open or removed. Operating the server in this manner results in an improper system airflow. For internal hot-plug component procedures, complete the procedure within 60 seconds. Failure to do so can cause the system temperature to increase and trip the safety threshold. When this happens:

- The health LED flashes amber.
- The operating system gracefully shuts down.

Procedure

1. Power down the server.
2. Remove all power:
 - a. Disconnect each power cord from the power source.
 - b. Disconnect each power cord from the server.
3. Disconnect all peripheral cables from the server.
4. If the server is in tower mode, place the server on a flat, level surface with the access panel facing up.
5. If the server is in rack mode, do one of the following:
 - Extend the server from the rack.
 - Remove the server from the rack.
6. Unlock the front bezel.
7. Remove the access panel:
 - a. If necessary, unlock the access panel latch.
 - b. To disengage the access panel from the chassis, press the release button and pull up the latch.
 - c. Lift the access panel.

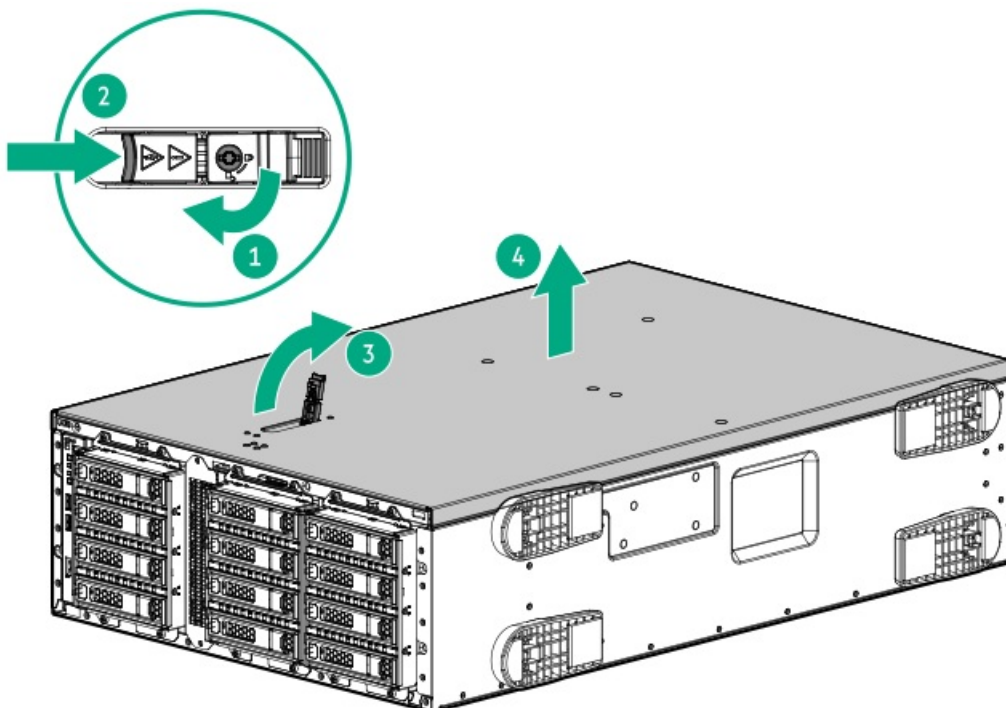

Remove the fan cage

Procedure

1. Power down the server.
2. Remove all power:
 - a. Disconnect each power cord from the power source.
 - b. Disconnect each power cord from the server.
3. Disconnect all peripheral cables from the server.
4. Do one of the following:
 - If the server is in tower mode, place the server on a flat, level surface with the access panel facing up.
 - If the server is in rack mode, remove the server from the rack.
5. Unlock the front bezel.
6. Remove the access panel.
7. Remove the existing internal fans:
 - a. Press and hold the latch.
 - b. Lift the fan from the bay.

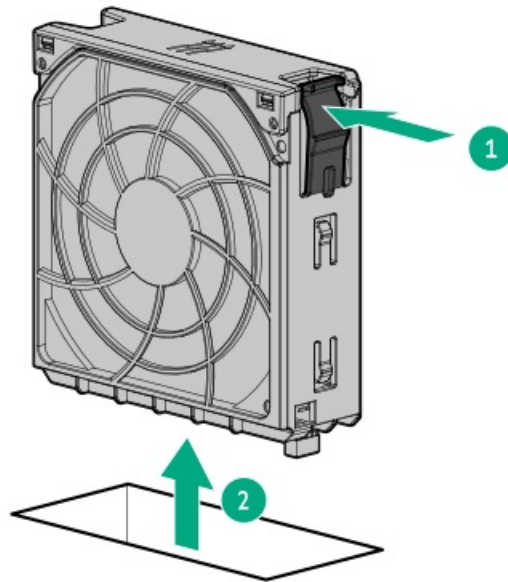

8. If installed, remove the fan blank from bay 1.

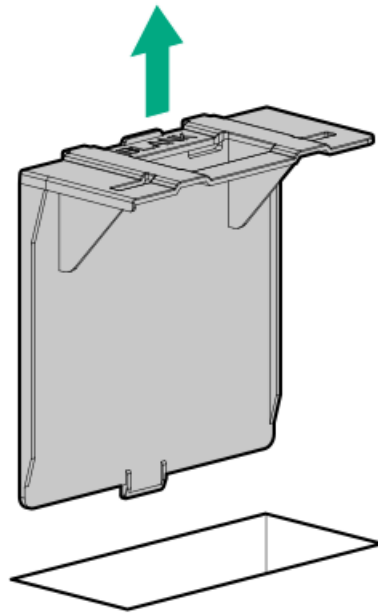

9. Disconnect the fan cage cables from the system board.
10. Remove the fan cage:
 - a. Open the fan cage latches.
 - b. Lift the fan cage away from the chassis.

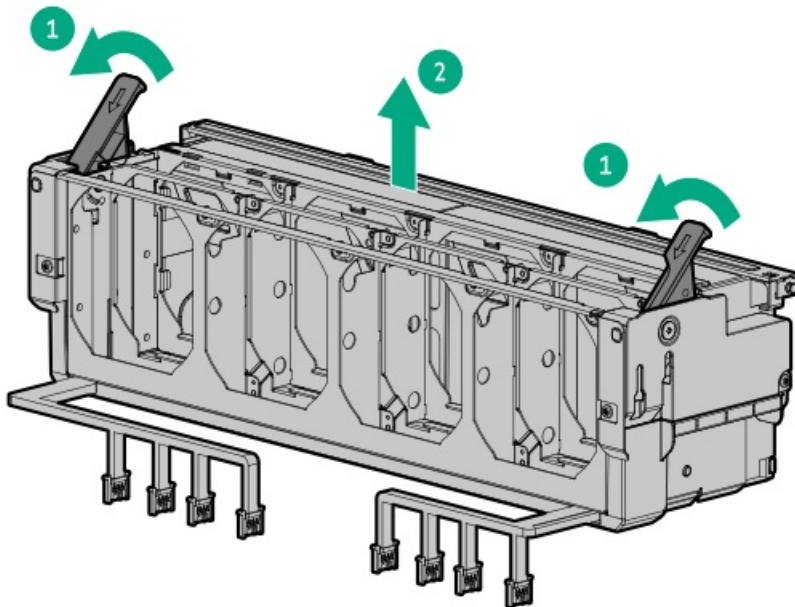

Remove the primary riser cage

Procedure



1. Power down the server.
2. Remove all power:
 - a. Disconnect each power cord from the power source.
 - b. Disconnect each power cord from the server.
3. Disconnect all peripheral cables from the server.
4. Do one of the following:
 - If the server is in tower mode, place the server on a flat, level surface with the access panel facing up.
 - If the server is in rack mode, remove the server from the rack.
5. Unlock the front bezel.
6. Remove the access panel.
7. If an expansion card with internal cables is installed on the riser, disconnect all cables from the expansion card.
8. Remove the primary riser cage:
 - a. Release the half-turn spring latch.
 - b. Lift the riser cage off the system board.

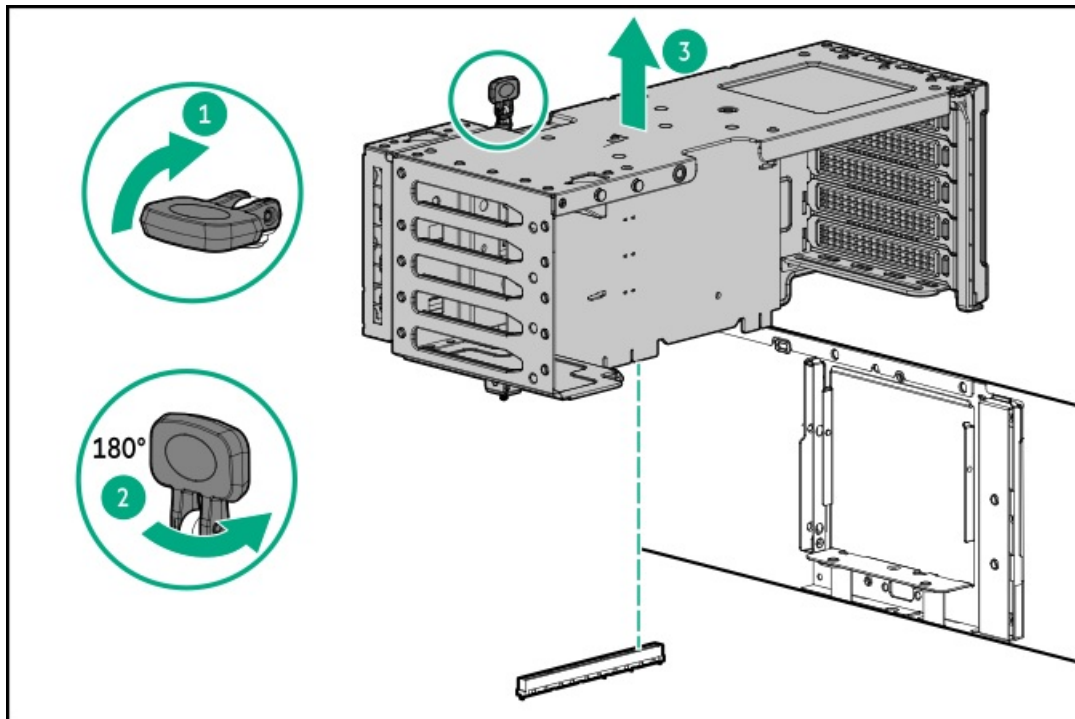

Remove the secondary riser cage blank

Prerequisites

Before you perform this procedure, make sure that you have a T-10 Torx screwdriver available.

About this task

CAUTION: To prevent improper cooling and thermal damage, do not operate the server unless all bays are populated with either a component or a blank.

Procedure

1. Power down the server.
2. Remove all power:
 - a. Disconnect each power cord from the power source.
 - b. Disconnect each power cord from the server.
3. Disconnect all peripheral cables from the server.
4. Do one of the following:
 - If the server is in tower mode, place the server on a flat, level surface with the access panel facing up.
 - If the server is in rack mode, remove the server from the rack.
5. Unlock the front bezel.
6. Remove the access panel.
7. Remove the secondary riser cage blank.

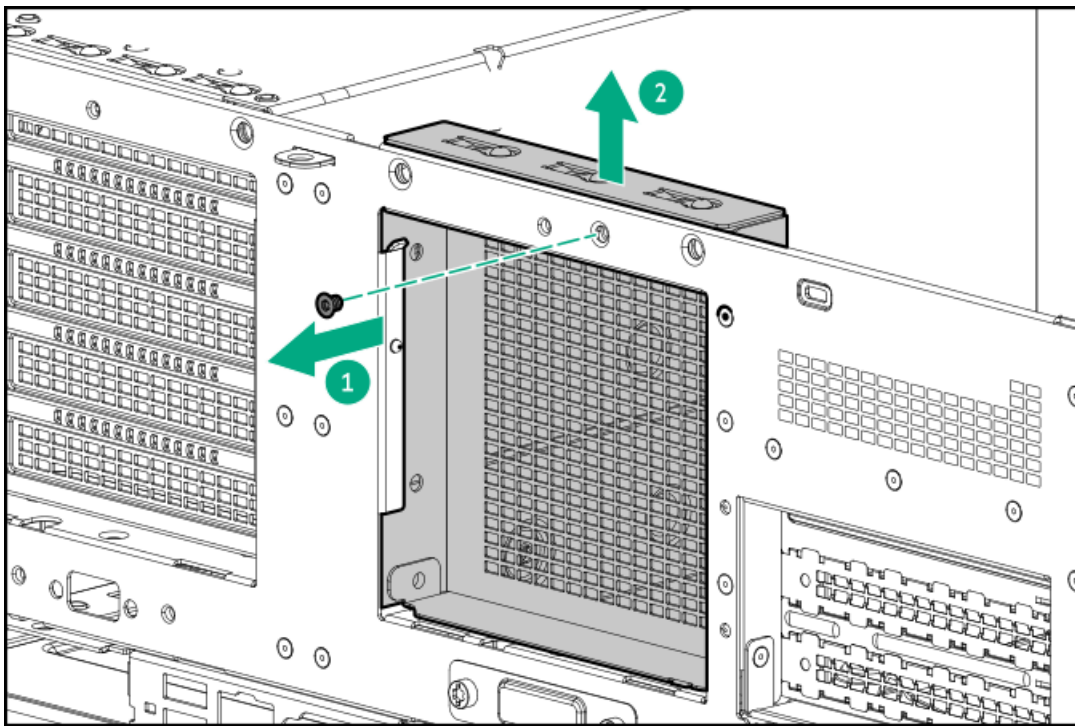

Remove the secondary riser cage

Procedure

1. Power down the server.
2. Remove all power:
 - a. Disconnect each power cord from the power source.
 - b. Disconnect each power cord from the server.
3. Disconnect all peripheral cables from the server.
4. Do one of the following:

- If the server is in tower mode, place the server on a flat, level surface with the access panel facing up.
 - If the server is in rack mode, remove the server from the rack.
5. Unlock the front bezel.
 6. Remove the access panel.
 7. If an expansion card with internal cables is installed on the riser, disconnect all cables from the expansion card.
 8. If installed, remove the expansion card from the tertiary riser:
 - a. Loosen the stabilizer bracket captive screw, and then pull the stabilizer bracket from the expansion card.

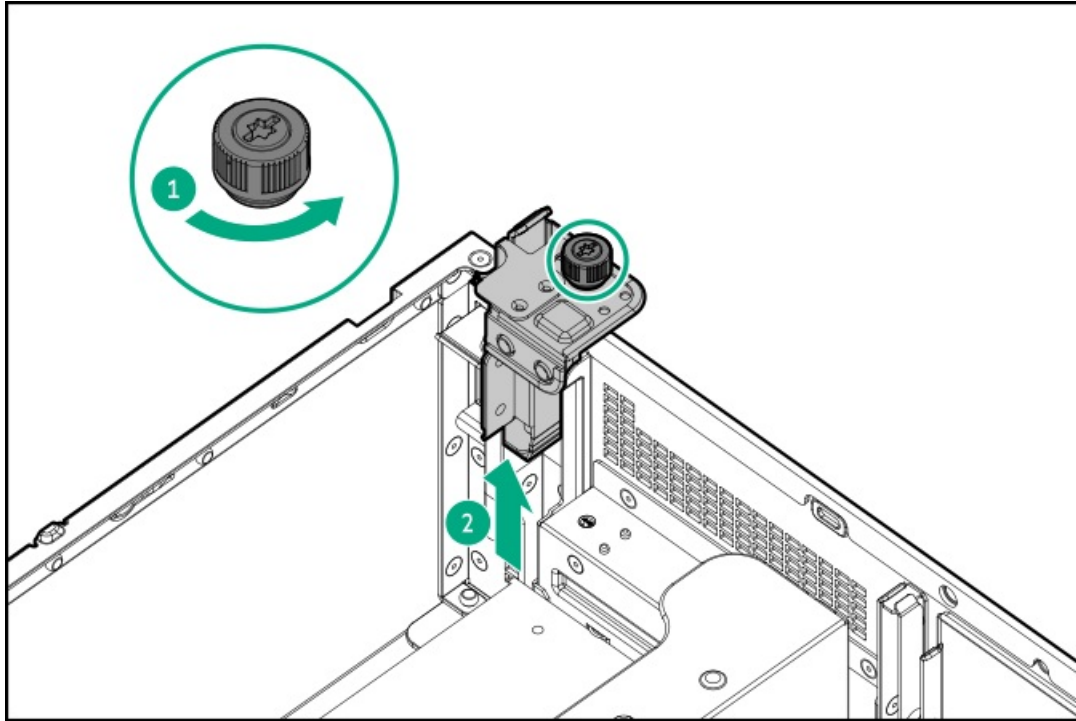

- b. Remove the expansion card from the tertiary riser.

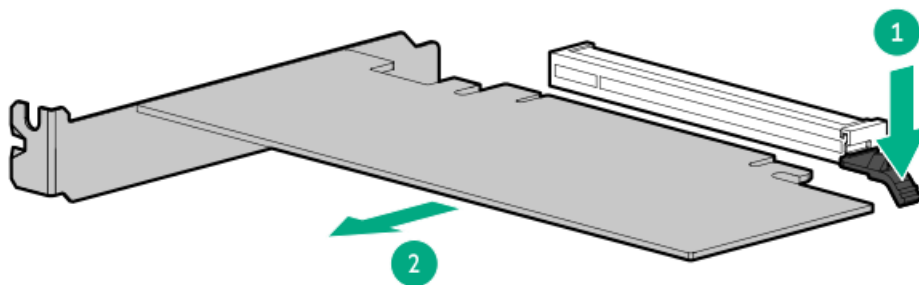

9. If installed, remove the tertiary riser.

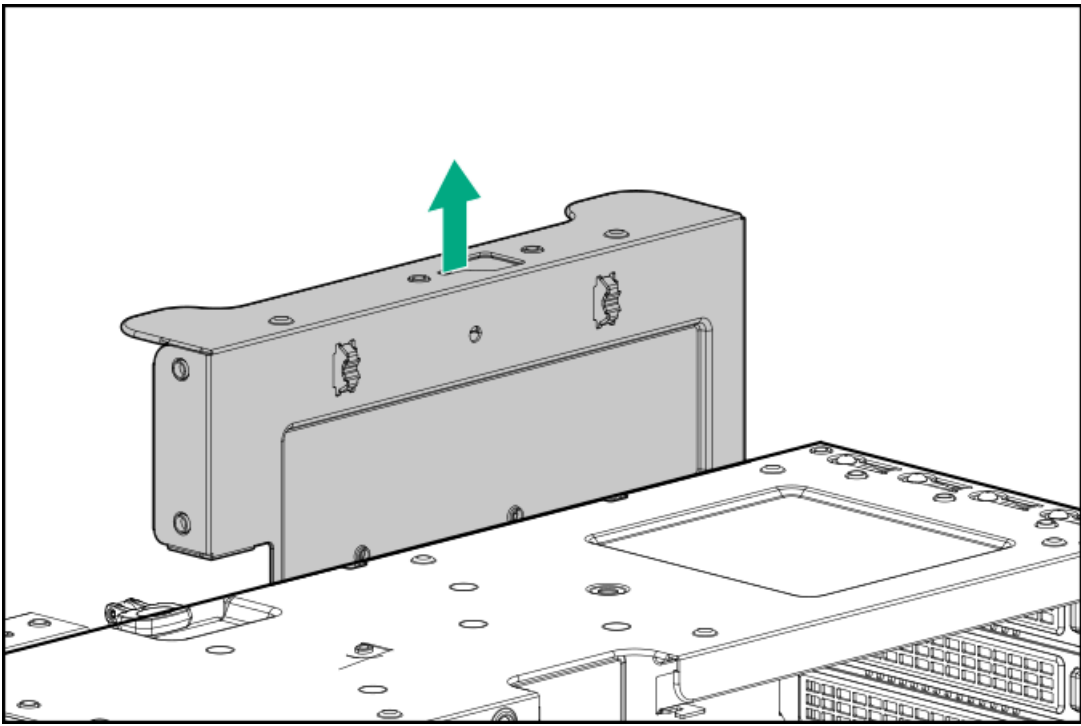

10. Remove the secondary riser cage:
 - a. Release the half-turn spring latch.
 - b. Lift the riser cage off the system board.

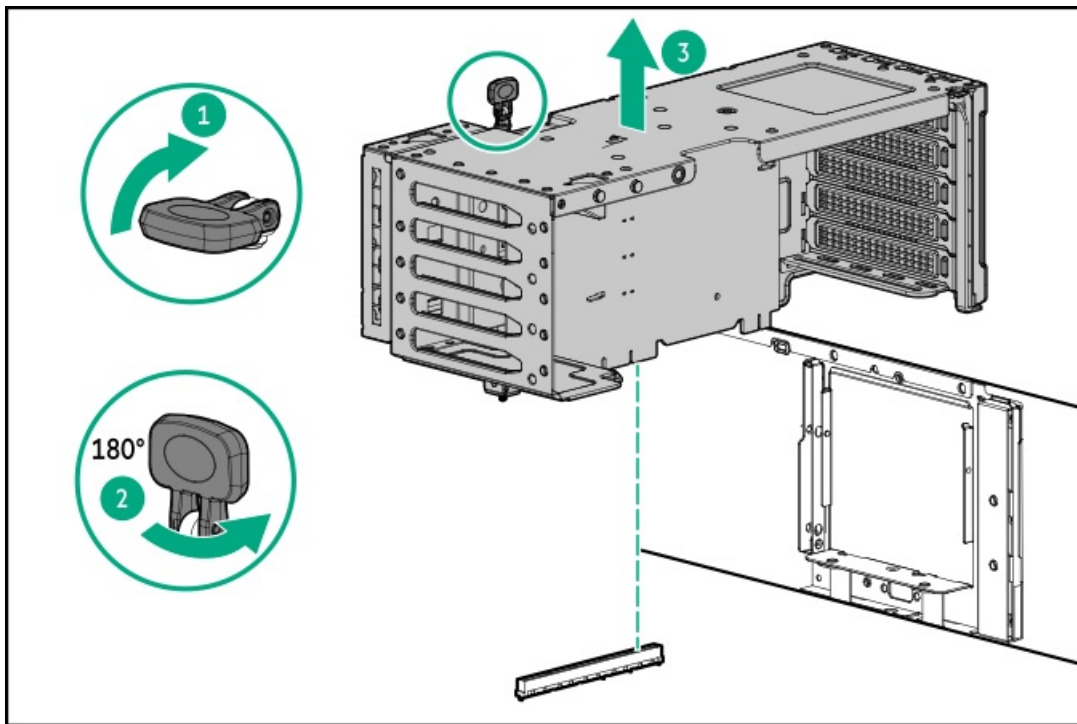

Remove the HPE NS204i-u Boot Device

Procedure

1. Power down the server.



2. Remove all power:
 - a. Disconnect each power cord from the power source.
 - b. Disconnect each power cord from the server.
3. Disconnect all peripheral cables from the server.
4. Do one of the following:
 - If the server is in tower mode, place the server on a flat, level surface with the access panel facing up.
 - If the server is in rack mode, remove the server from the rack.
5. Unlock the front bezel.
6. Remove the access panel.
7. Remove the boot device from the top of the power supply cage:
 - a. Pull and hold the latch.
 - b. Remove the boot device from the chassis side wall.

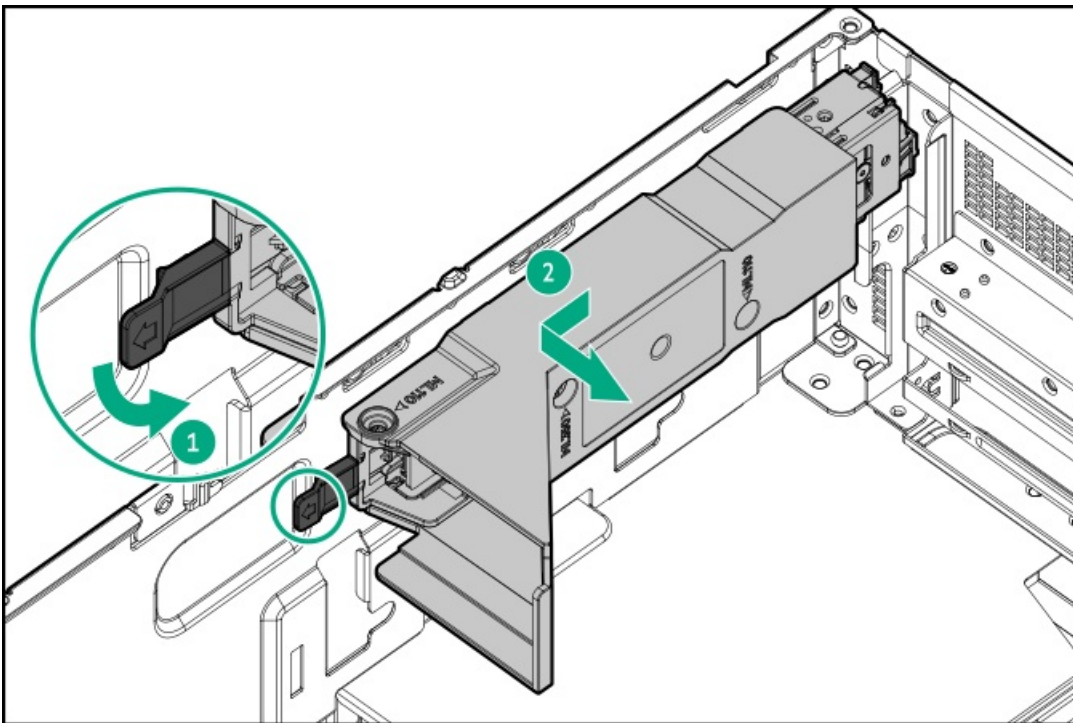

Install the primary/secondary riser cage

Procedure

1. Install the primary/secondary riser cage:
 - a. Carefully press the riser down on its system board connector.
Make sure that:
 - The riser cage is aligned with the rear chassis.
 - The riser board is firmly seated on the system board.
 - b. Simultaneously push and rotate the half-turn spring latch to 180°.

c. Close the spring latch.

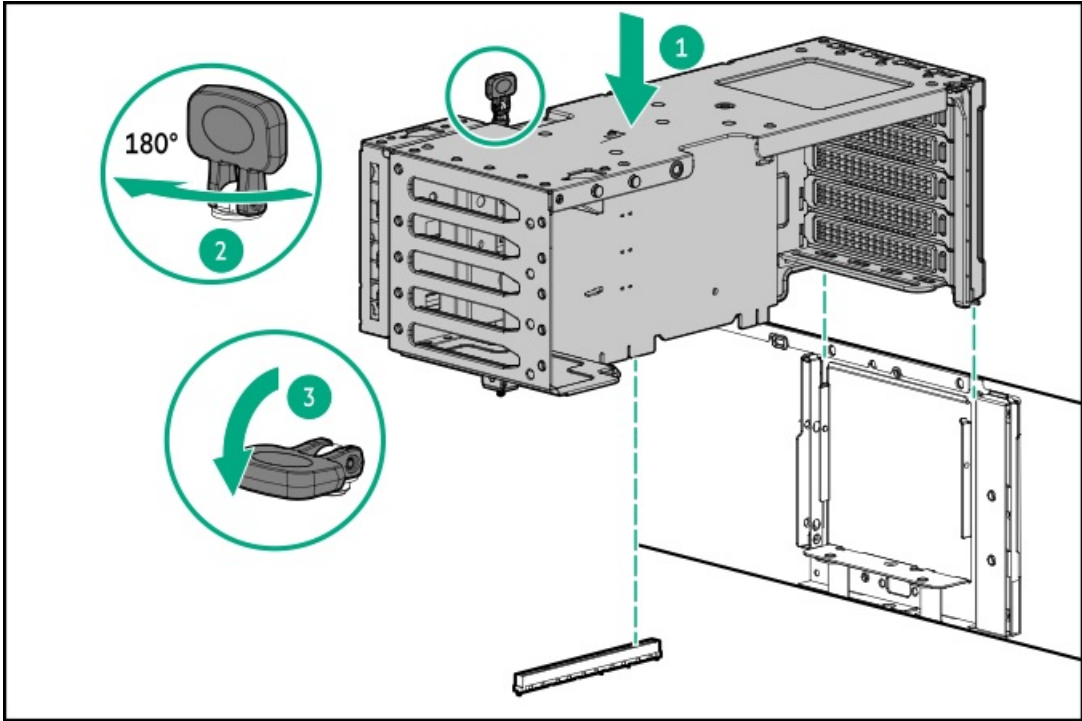

2. If removed, install the tertiary riser:

a. Install the tertiary riser on the secondary riser cage.

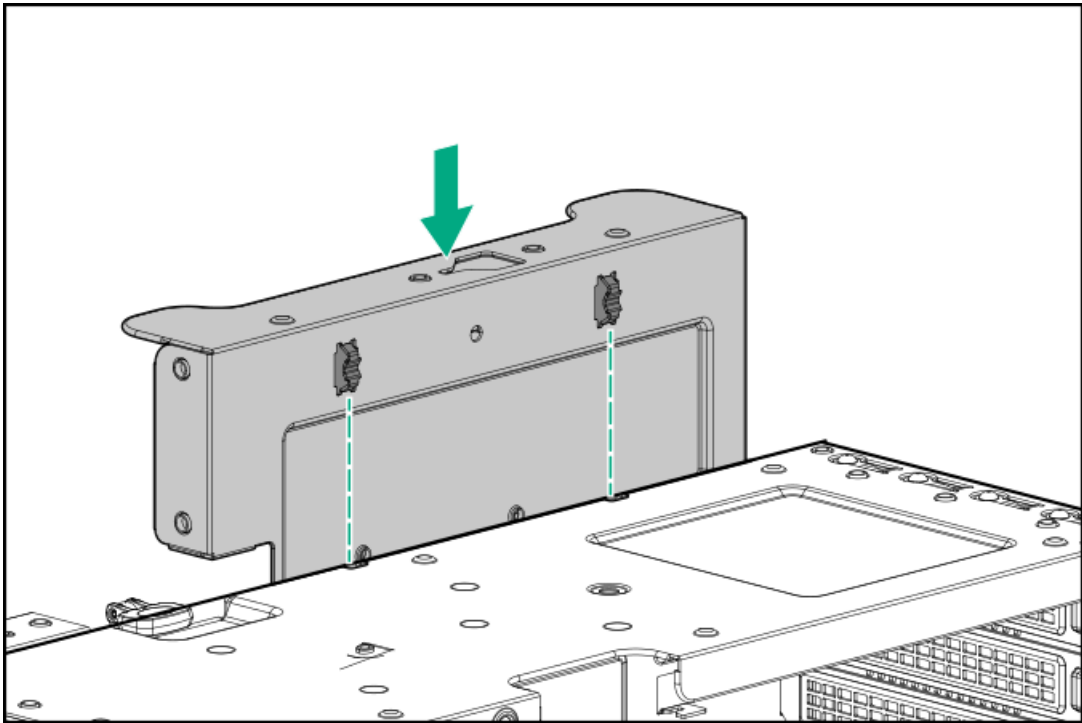

b. Install the expansion card.



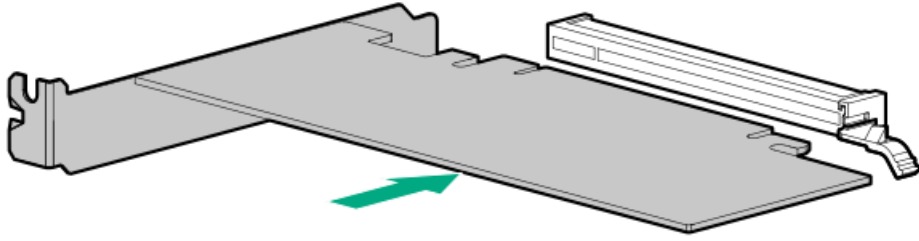

- c. Press down the stabilizer bracket to secure the expansion card, and then tighten the captive screw.

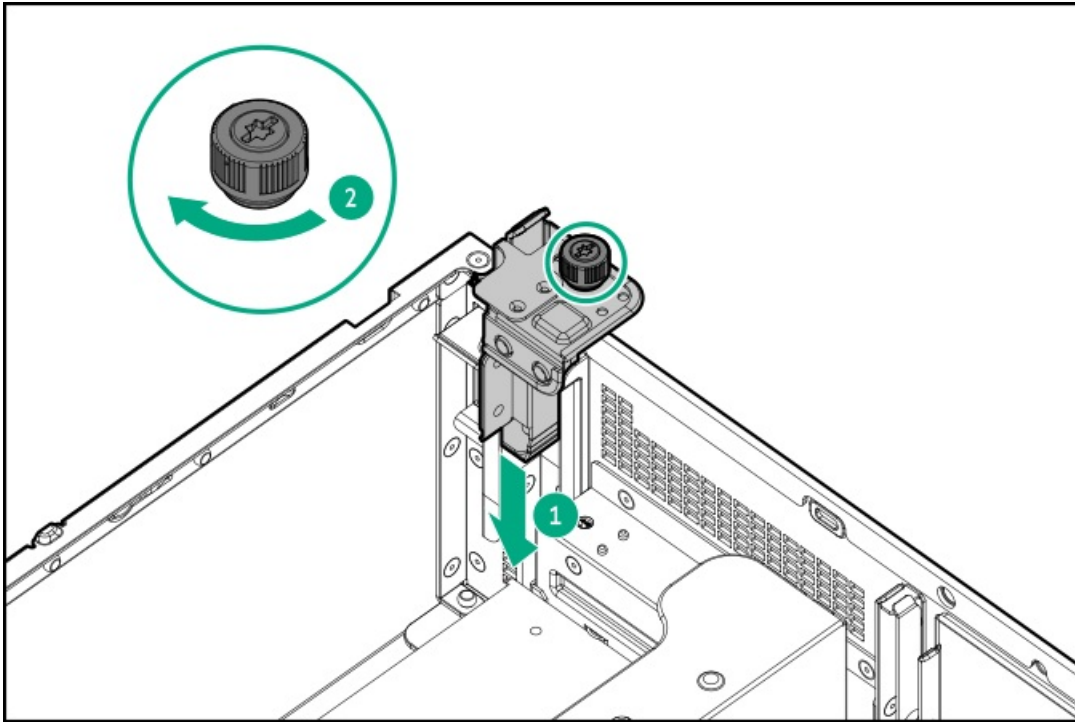

3. Perform the post-installation or maintenance steps required by the procedure that necessitates the removal of the riser cage.

Install the fan cage

Procedure

1. Install the fan cage:
 - a. Lower the fan cage into the chassis.
 - b. Close the fan cage latches.



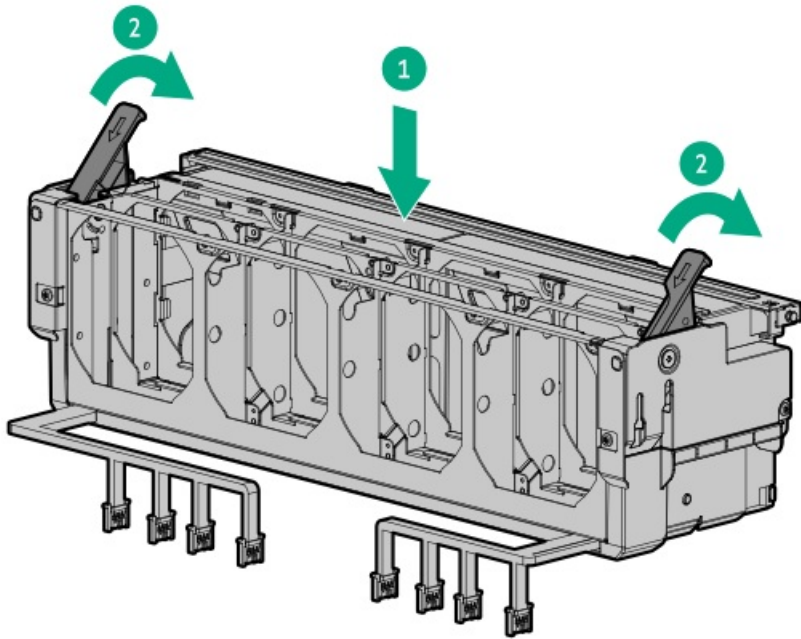

2. Connect the fan cage cables to the system board.
3. Install all internal fans:
 - a. Lower the fan into the bay.
 - b. Press down on the fan to make sure that it is seated firmly in the bay.
A click sound indicates that the fan is properly engaged.

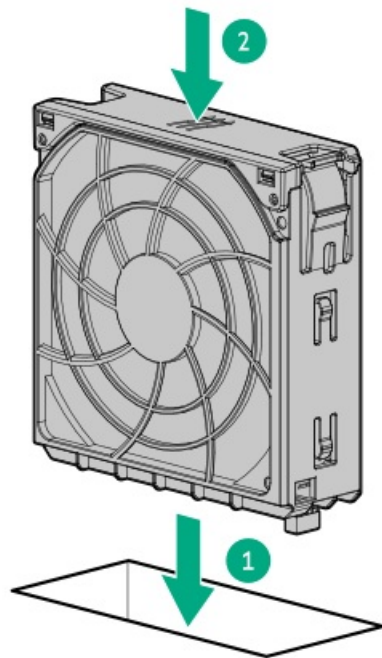

4. If removed, reinstall the fan blank into bay 1.

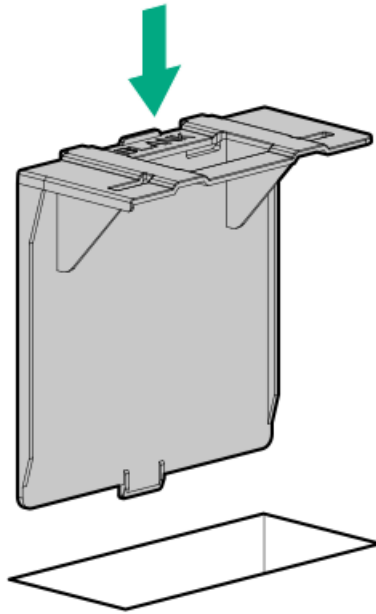

5. Perform the post-installation or maintenance steps required by the procedure that necessitates the removal of the fan cage.

Install the access panel

Prerequisites

Before you perform this procedure, make sure that you have a T-15 Torx screwdriver available.

Procedure

1. With the access panel latch open, insert the guide pin on the chassis through the hole on the bottom side of the latch.
2. Close the access panel latch.
The access panel slides to the closed position.
3. Lock the access panel latch.

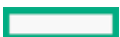

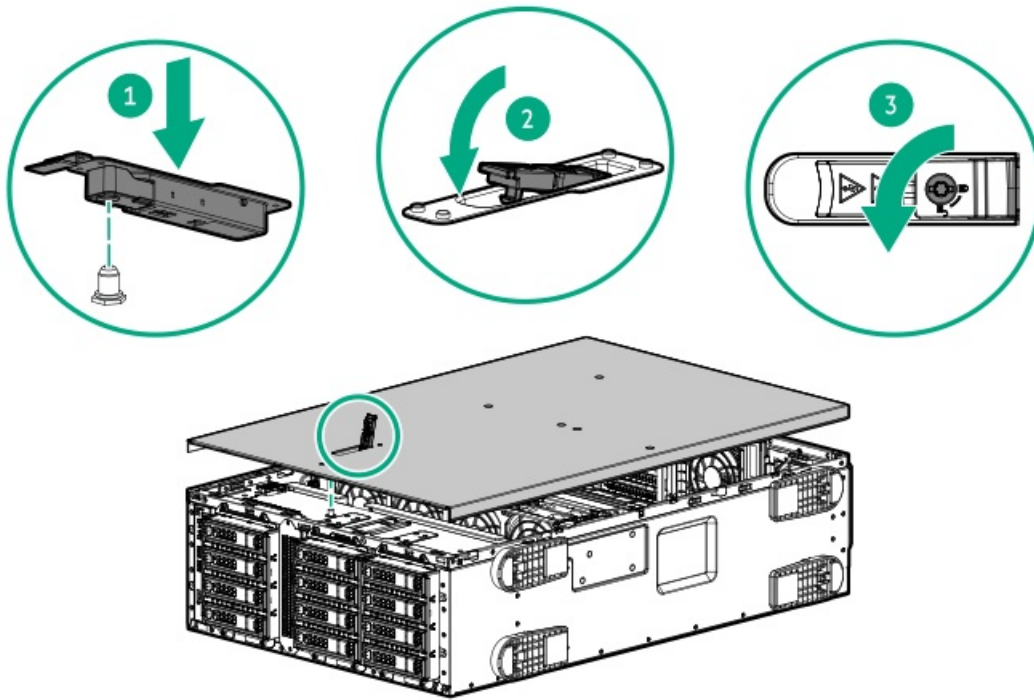

4. Perform the post-installation or maintenance steps required by the procedure that necessitates the removal of the access panel.

Position the tower server for operation

Procedure

1. Return the server to an upright position.
2. Rotate the chassis feet outward to stabilize the server.

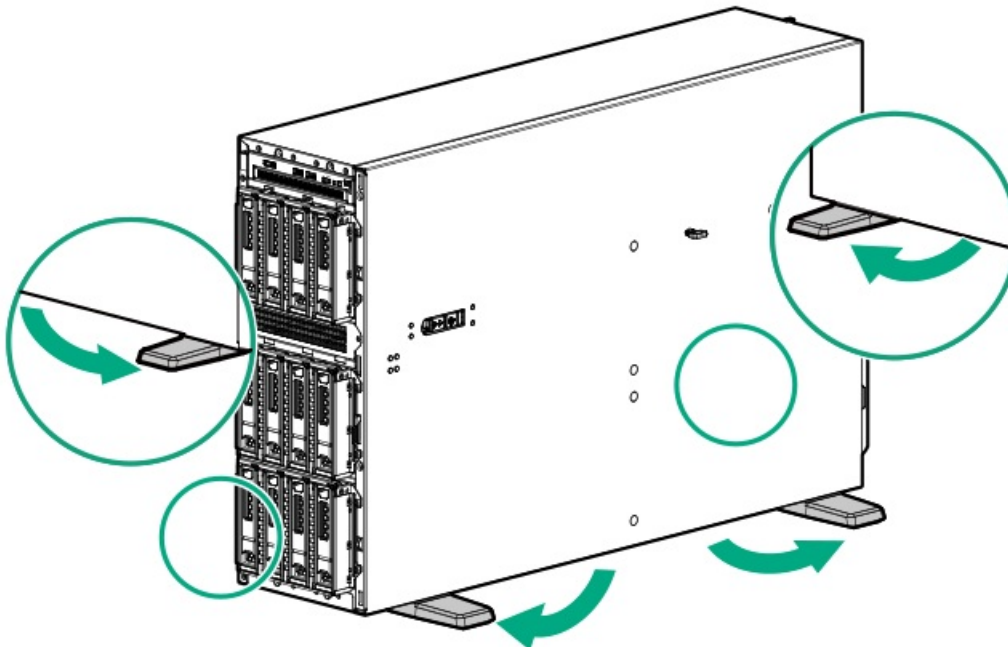

Install the front bezel

Procedure

1. Insert the front bezel hooks to the chassis.
2. Close the front bezel.
3. While pressing the key against the lock, rotate the key to the lock position.

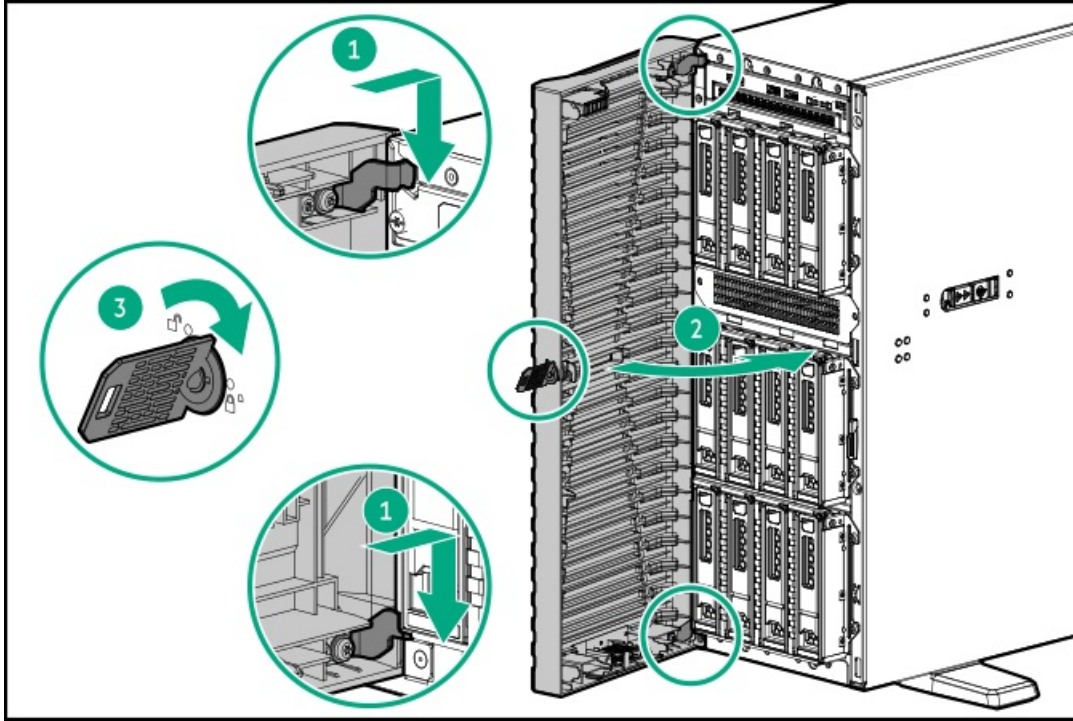

4. (Optional) For later use, store the front bezel keys inside the front bezel.

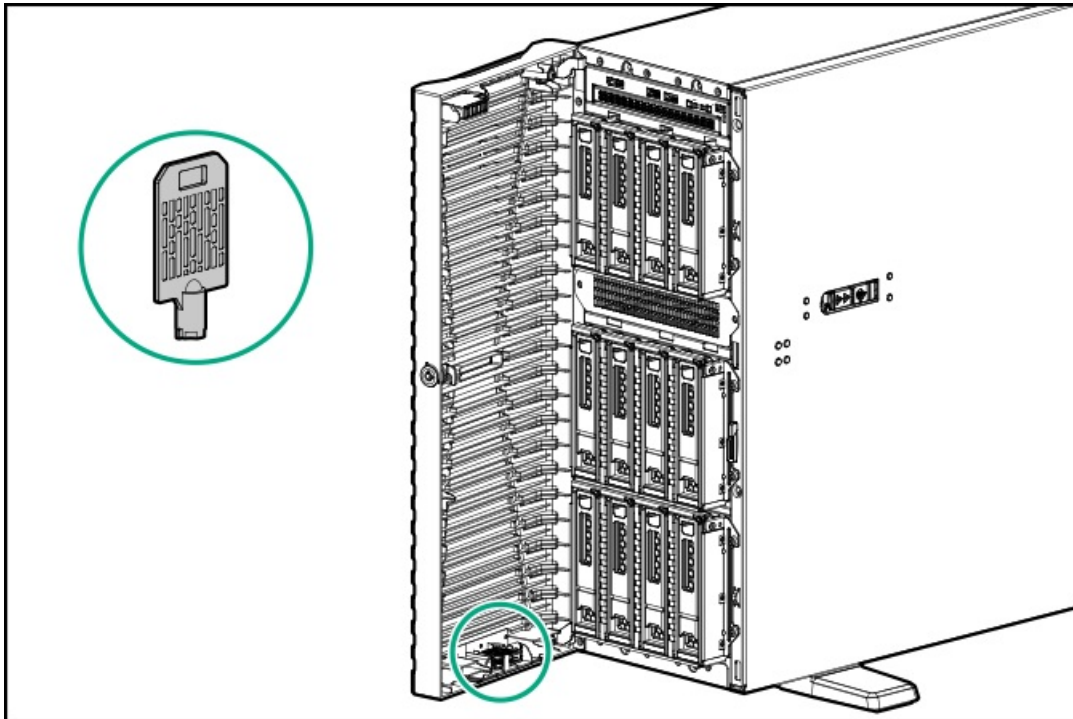

Install the server into the rack

Prerequisites

- Get help to lift and stabilize the server during rack installation. **If the server is installed higher than chest level, an additional two people might be required to help install the server:** One person to support the server weight, and the other two to slide the server into the rack.
- Before you perform this procedure, review the:
 - [Rack warnings and cautions](#)
 - [Server warnings and cautions](#)
- A fully populated server is heavy. Hewlett Packard Enterprise recommends removing the external chassis components before removing the server from the rack.
- Before you perform this procedure, make sure that you have a T-15 Torx screwdriver available.

Procedure

1. Grasp the tray notch to slide the tray out of the rack.

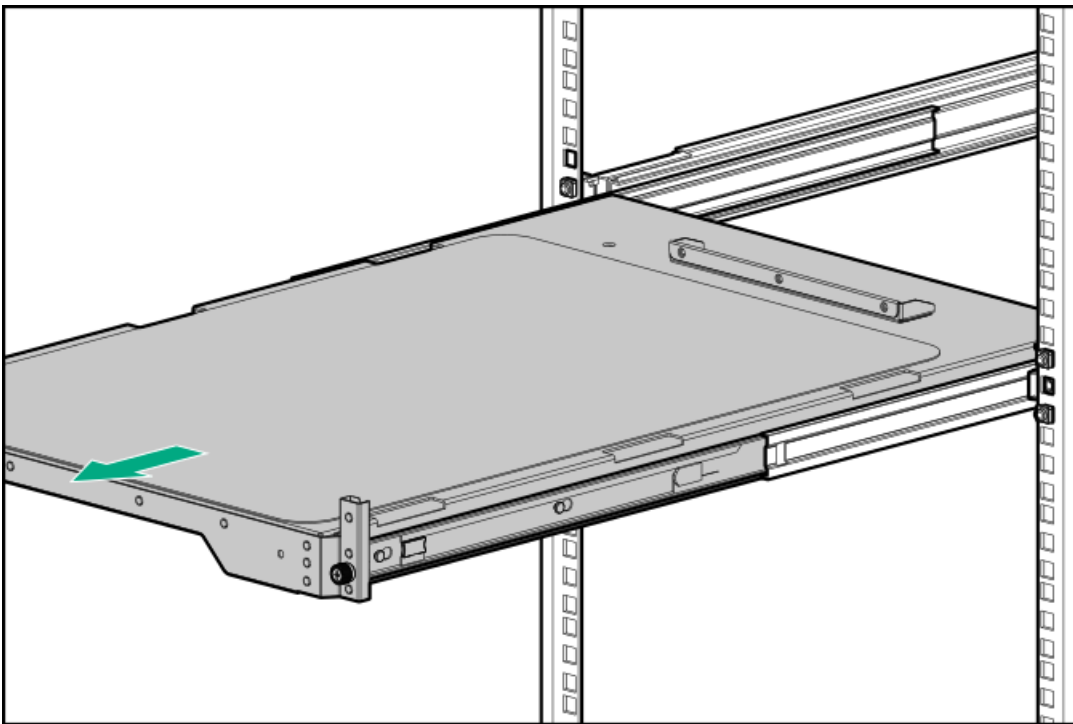

2. Place the server on the tray.

Verify that the front panel of the server is aligned with the front of the tray.

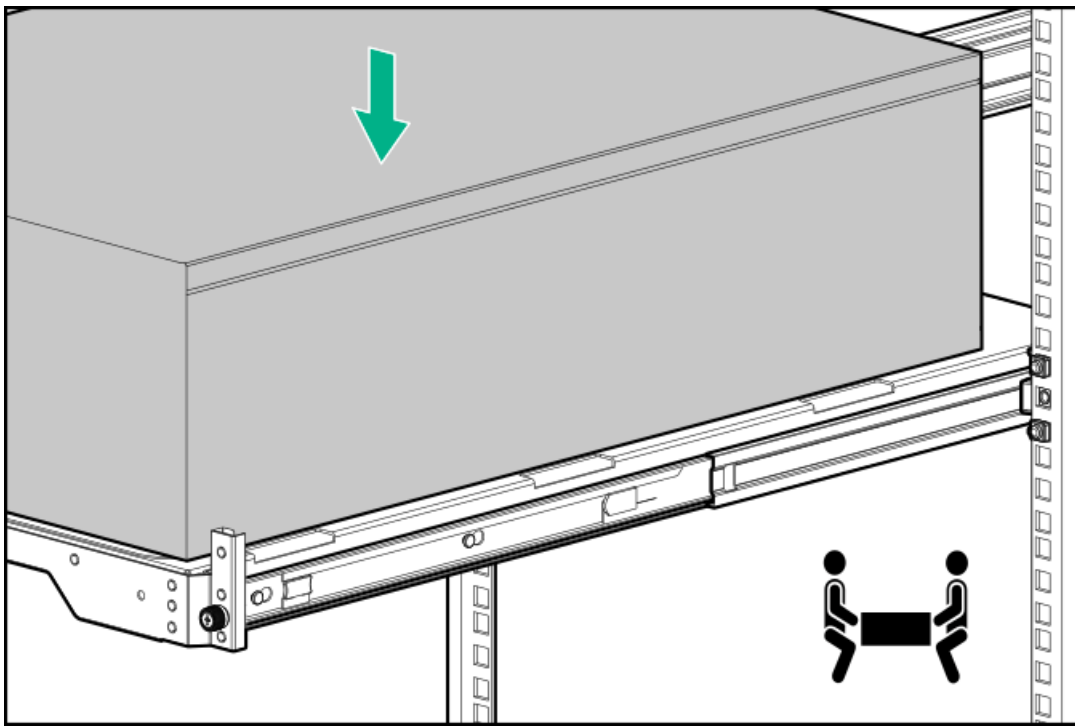

3. Install the chassis rear bracket screws.

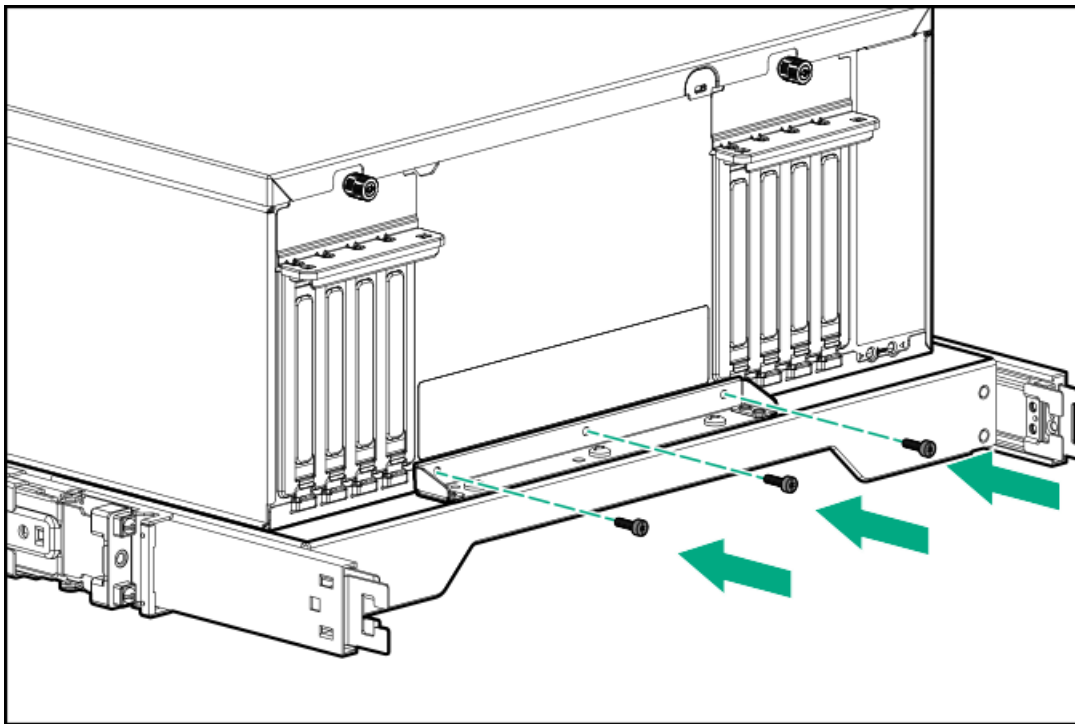

4. Press and hold the blue rail-release tabs, and then slide the tray back into the rack.



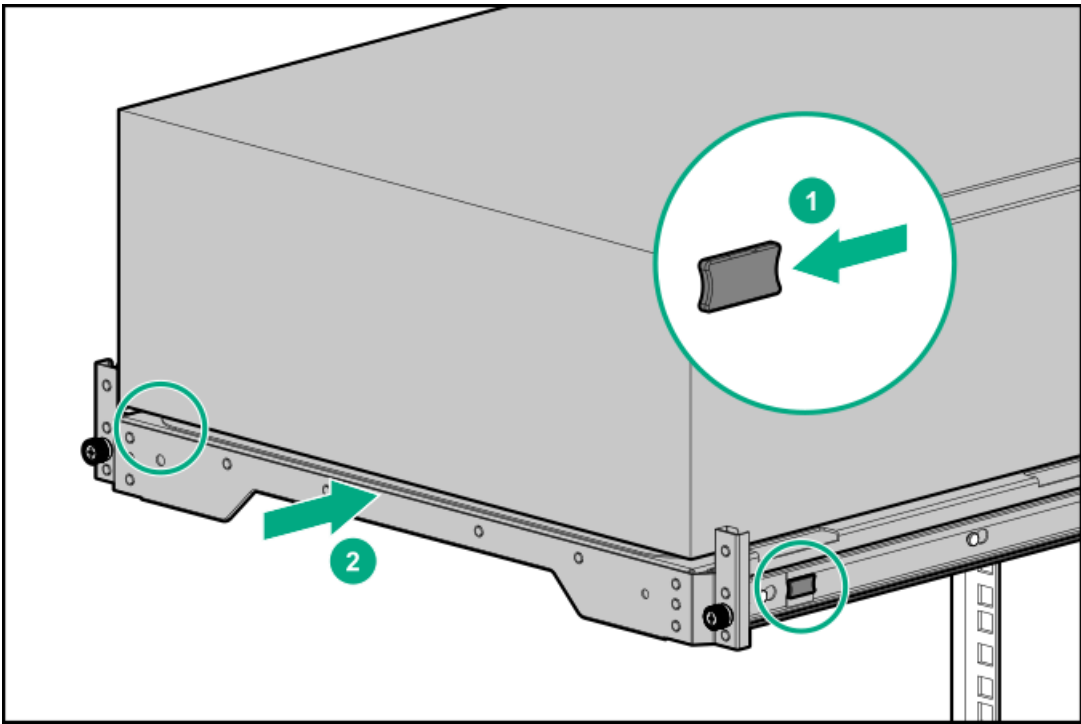

5. Tighten the server tray thumbscrews.

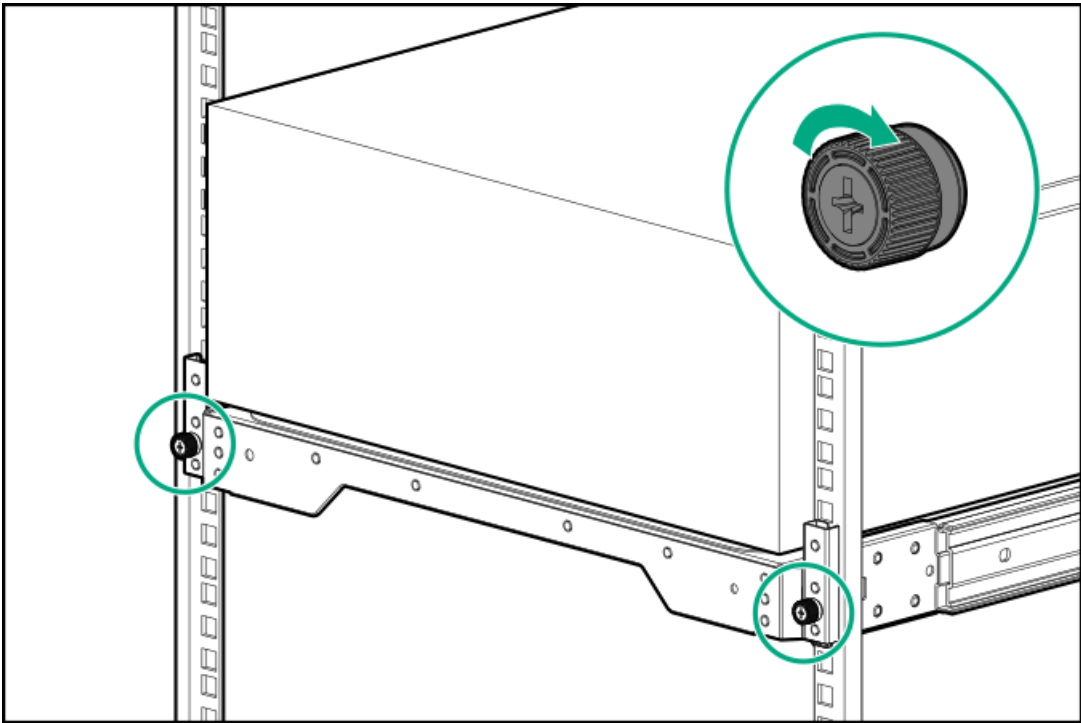

6. Connect all peripheral cables to the server.
7. Connect each power cord to the server.
8. Connect each power cord to the power source.
9. Power up the server.

Power up the server



Procedure

- Press the Power On/Standby button.
- Use the virtual power button through iLO 6.

Installing the shipping hardware

Prerequisites

Before you perform this procedure, make sure that you have the following items available:

- Cage nut insertion tool
- T-25 Torx screwdriver
- Phillips No. 2 screwdriver

About this task

If you intend to transport or ship a rack-mounted server to a new location, make sure that the shipping hardware is installed. The shipping hardware protects the server from vibration damage that might occur during server shipment.

Procedure

1. Power down the server.
2. Remove all power:
 - a. Disconnect each power cord from the power source.
 - b. Disconnect each power cord from the server.
3. Disconnect all peripheral cables from the server.
4. With the server installed in the rack, hold the shipping bracket against the rack column and note the correct mounting locations for both the brackets and the cage nuts as shown in the following image.

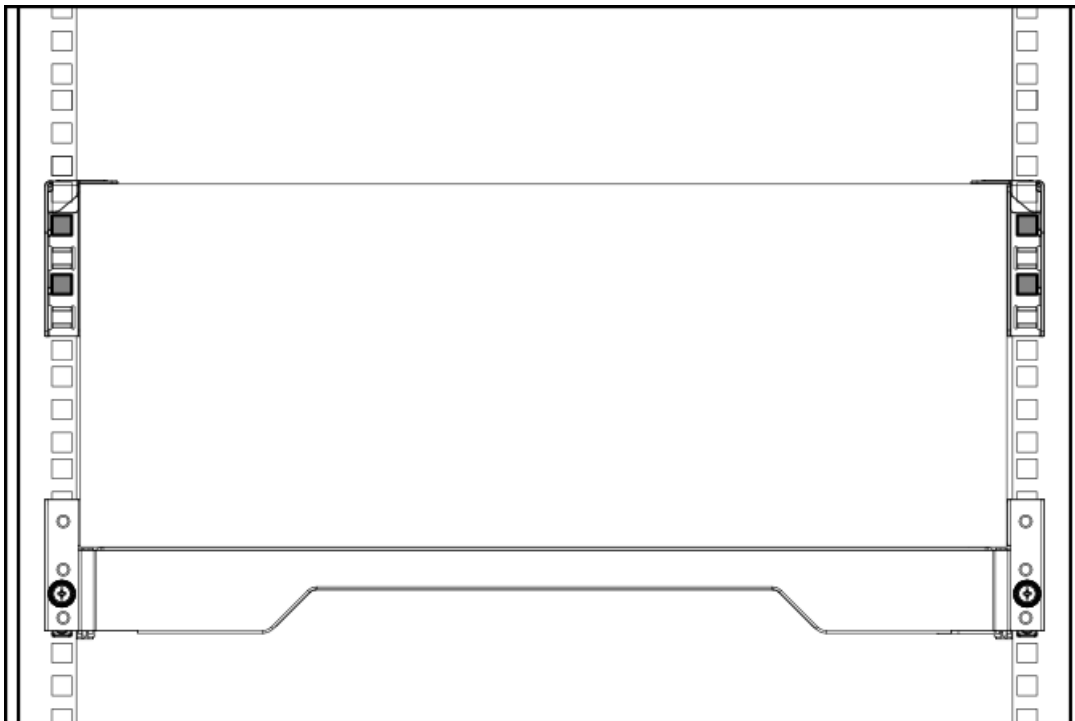

5. Slide the server tray out of the rack:
 - a. Loosen the server tray thumbscrews.
 - b. Grasp the tray notch and slide the server out of the rack.

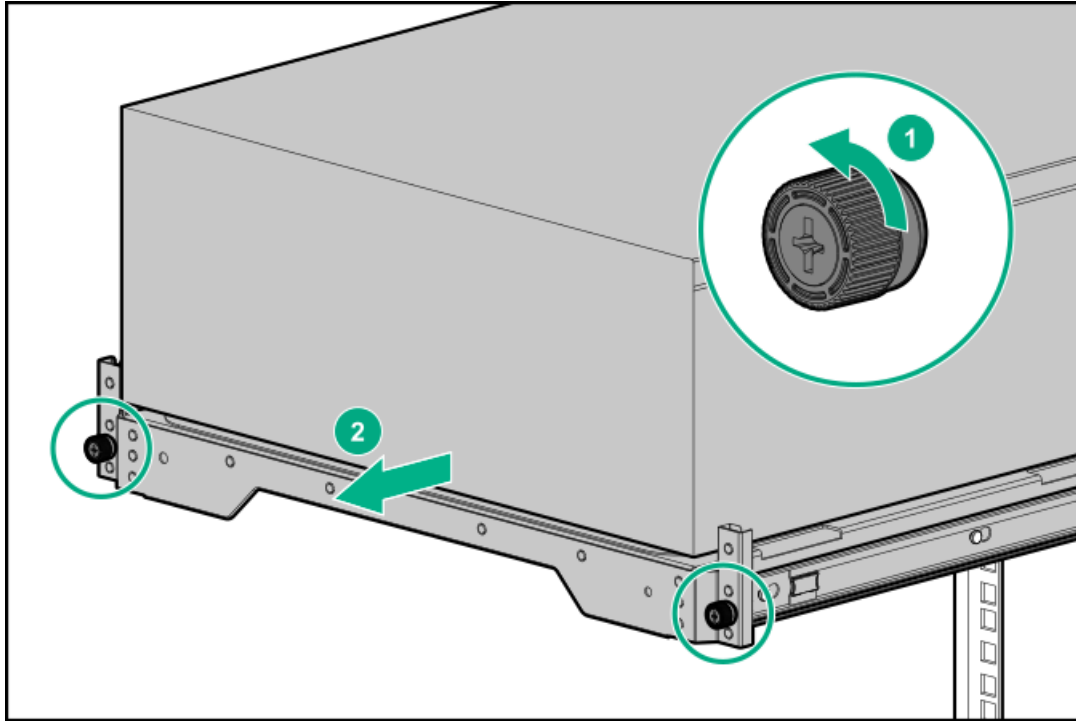

6. If you are installing the server in a square-hole rack, install the cage nuts. When installed, the flanges on the cage nut should face the outside of the rack:
 - a. Hook the bottom flange of the cage nut in the rack hole.
 - b. Insert the tip of the insertion tool through the hole and hook the top flange of the cage nut.
 - c. Use the insertion tool to pull the cage nut through the hole until the top flange snaps into position.

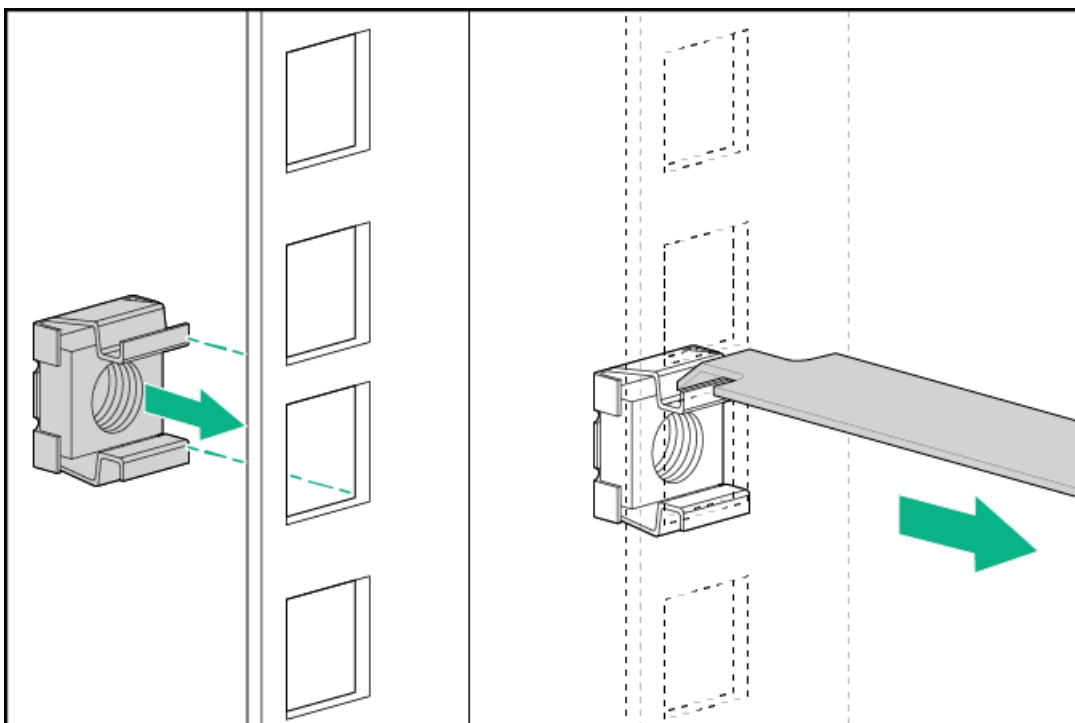

7. Secure the front end of rack rails to the rack columns with the shipping brackets.

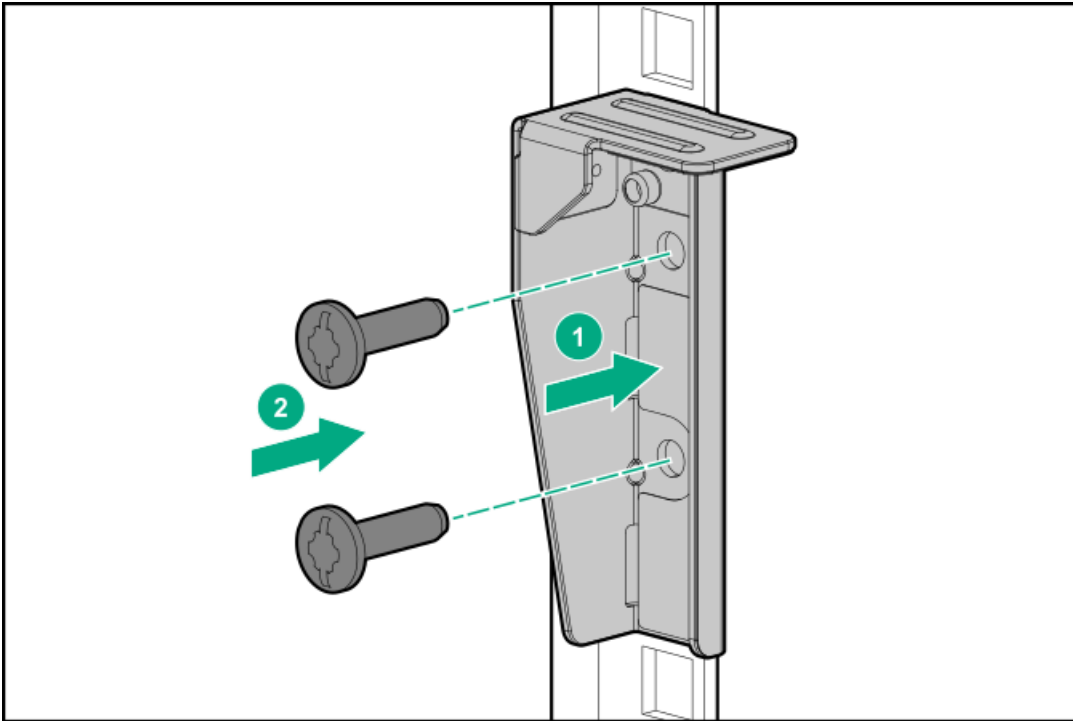

8. Secure the rear end of rack rails to the rack columns with the rear shipping screws.

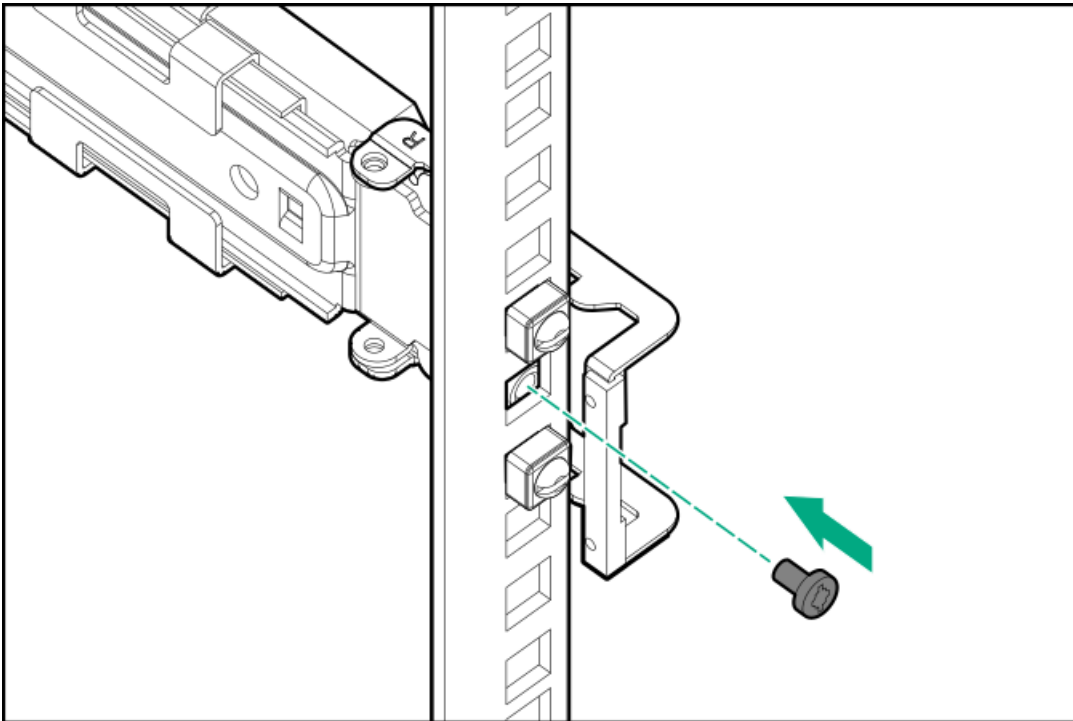

Results

The installation is complete.

Hardware options installation

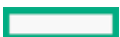

This chapter provides instructions for installing supported hardware options. To ensure proper server deployment and operation, Hewlett Packard Enterprise recommends installing only HPE-validated hardware options. To see the list of validated options for this server, see the product QuickSpecs on the HPE ProLiant ML350 Gen11 Server website:

<https://www.hpe.com/info/quickspecs>

To view the warranty for your server and supported options, see [Warranty information](#).

Subtopics

[Server data backup](#)

[Hardware option installation guidelines](#)

[Hewlett Packard Enterprise product QuickSpecs](#)

[Tower-to-rack conversion kit](#)

[Drive options](#)

[Power supply options](#)

[Drive cage options](#)

[Media device options](#)

[Transceiver option](#)

[Fan options](#)

[Memory option](#)

[Secondary riser cage and tertiary riser options](#)

[Storage controller options](#)

[Energy pack options](#)

[Expansion card options](#)

[Processor heatsink assembly option](#)

[HPE NS204i-u Boot Device option](#)

[OCP NIC 3.0 adapter option](#)

[Chassis intrusion detection switch option](#)

[Serial port option](#)

[Internal USB device options](#)

Server data backup

To avoid data loss, make sure to back up all server data before installing or removing a hardware option, performing a server maintenance, or a troubleshooting procedure.

Server data in this context refers to information that may be required to return the system to a normal operating environment after completing a hardware maintenance or troubleshooting procedure. This information may include:

- User data files
- User account names and passwords
- Application settings and passwords

- Component drivers and firmware
- TPM recovery key/password
- BIOS configuration settings—Use the backup and restore function in UEFI System Utilities. For more information, see the UEFI user guide (<https://www.hpe.com/info/UEFI-manuals>).
 - Custom default system settings
 - Security passwords including those required for power-on and BIOS admin access, persistent memory, and Server Configuration Lock (for HPE Trusted Supply Chain servers)
 - Server serial number and the product ID
- iLO-related data—Use the iLO backup and restore function. For more information, see the iLO user guide (<https://www.hpe.com/support/ilo6>).
 - iLO license
 - Customer iLO user name, password, and DNS name
 - iLO configuration settings
- For servers managed by HPE GreenLake for Compute Ops Management, make sure that you have your HPE GreenLake account ID. For more information, see [HPE GreenLake for Compute Ops Management Getting Started Guide](#).

Hardware option installation guidelines



WARNING: To reduce the risk of personal injury from hot surfaces, allow the drives and the internal system components to cool before touching them.



CAUTION:

To avoid data loss, Hewlett Packard Enterprise recommends that you [back up all server data](#) before installing or removing a hardware option, or performing a server maintenance or troubleshooting procedure.



CAUTION:

To prevent damage to electrical components, properly ground the server before beginning any installation, removal, or replacement procedure. Improper grounding can cause [electrostatic discharge](#).

- Install any hardware options before initializing the server.
- If multiple options are being installed, read the installation instructions for all the hardware options to identify similar steps and streamline the installation process.
- If the hardware option installation involves internal cabling, review the [Cabling guidelines](#).

Hewlett Packard Enterprise product QuickSpecs

To learn more about your product, search the Hewlett Packard Enterprise website (<https://www.hpe.com/info/quickspecs>) for the product QuickSpecs:

- Supported options
- Supported configurations
- Component compatibility



- New features
- Specifications
- Part numbers

Tower-to-rack conversion kit

Use the tower-to-rack conversion kit to switch the tower server to rack mode operation. A rack-mounted server occupies 5U space in the rack and supports in-rack serviceability for all server components.

Kit contents

- Left and right rack rail assemblies
- Server tray
- Cable management arm
- Chassis rear bracket screws (3)
- Shipping hardware—Install these hardware only if you intend to transport or ship a rack-mounted server to a new location.
 - Shipping brackets (2)
 - Shipping bracket screws (4)
 - M5 square-hole cage nuts (4)
 - Rear shipping screws (2)

Rack rail specifications

This server supports the HPE tower-to-rack conversion kit (P47394-B21). This tower-to-rack conversion kit supports the following specifications:

- Type: Ball-bearing (stab-in)
- Minimum rail length: 727.50 mm (28.64 in)
- Rail adjustability range: 570.00–812.00 mm (22.50–32.00 in)

Subtopics

[Installing the tower-to-rack conversion kit](#)

Installing the tower-to-rack conversion kit

About this task

In this procedure, left and right terminology is from the perspective of a user facing the front of the rack.

Procedure

1. Power down the server.
2. Remove all power:
 - a. Disconnect each power cord from the power source.
 - b. Disconnect each power cord from the server.
3. Disconnect all peripheral cables from the server.



4. If the server is in tower mode, place the server on a flat, level surface with the access panel facing up.
5. Remove the chassis feet:
 - a. Loosen the screws on the chassis.
 - b. Detach the chassis feet.

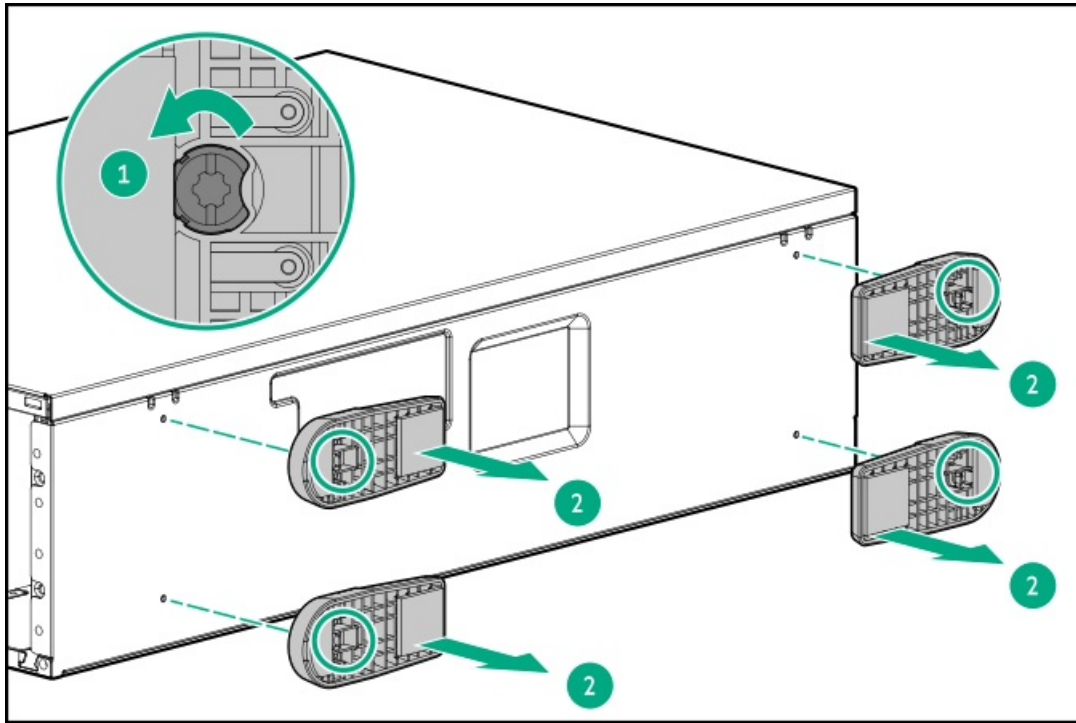

6. Install the rack rails and server tray.
7. Install the server into the rack.
8. Install the cable management arm.

Results

The installation is complete.

Subtopics

[Install the rack rails and server tray](#)

[Install the server into the rack](#)

[Install the cable management arm](#)

Install the rack rails and server tray

About this task

The rack rails can be installed in a round-hole or a square-hole racks. The rack rails occupy 1U space in the rack.

Procedure

1. Disassemble the rack rail assemblies:
 - a. Pull out the inner sliding rail until it is fully extended.
 - b. Slide and hold the white release tab in the direction shown, and then remove the sliding rail from the mounting rail.

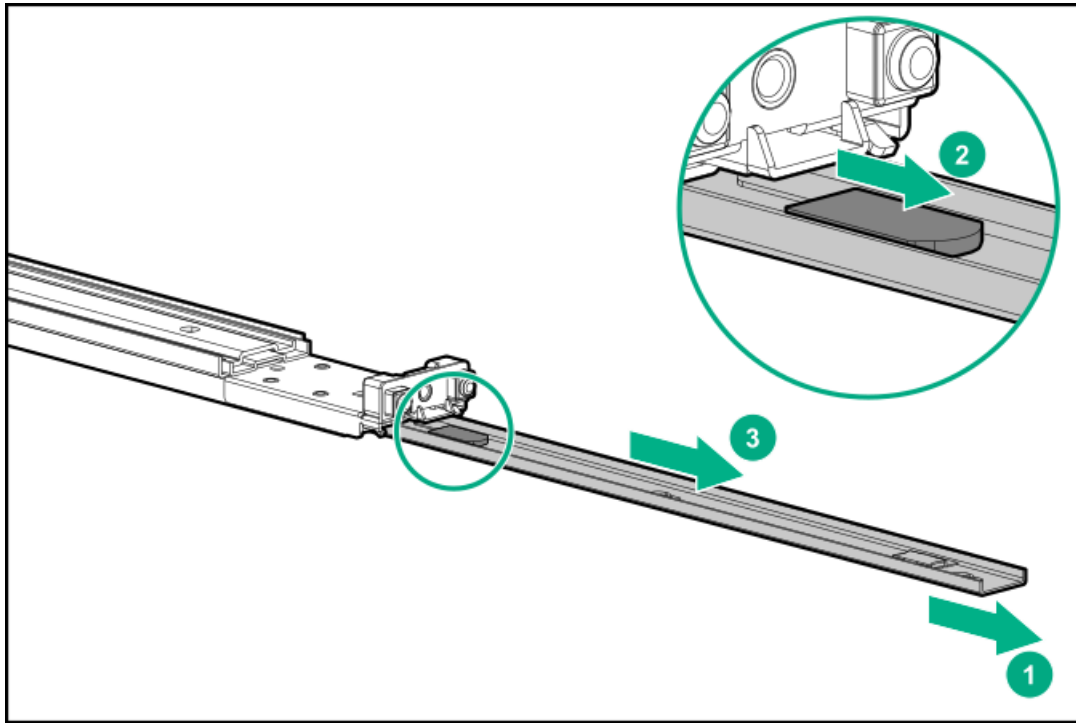

2. Install the sliding rails on the server tray:

- a. Insert the spools on the sides of the server tray through the notches on the rails.
- b. Slide the rail towards the rear of the tray to lock it into place.

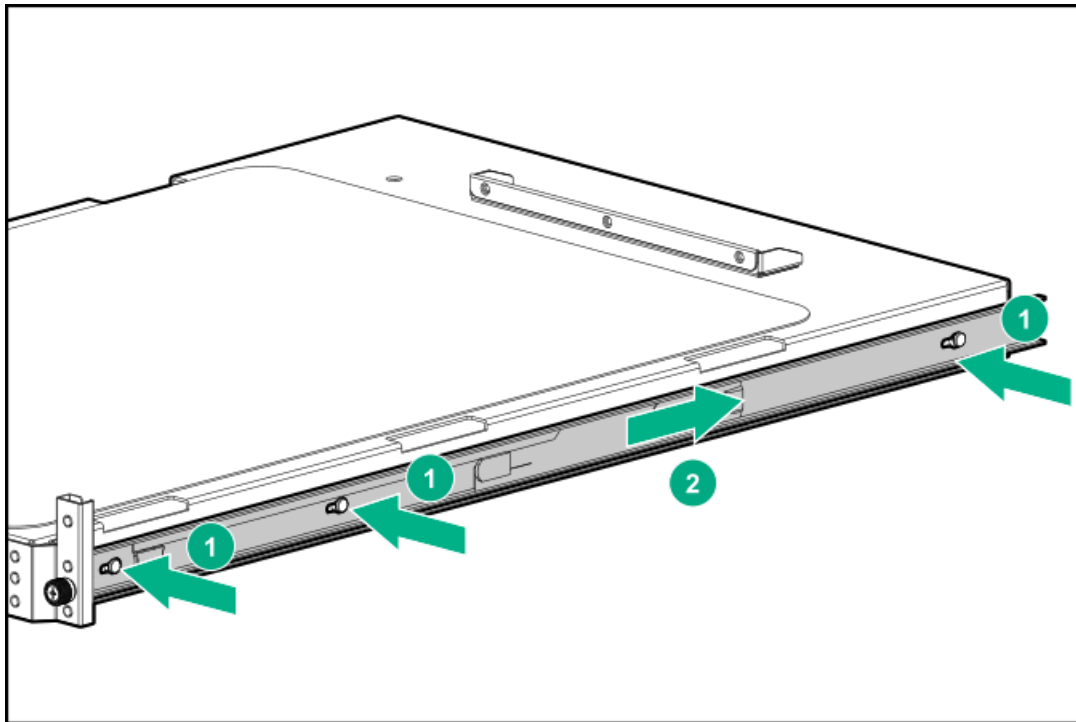

3. Locate the orientation markers on the mounting rails:

- The front end of the rails is marked **FRONT**.
- The rear end of the rail is marked with **L** for left and **R** for right.



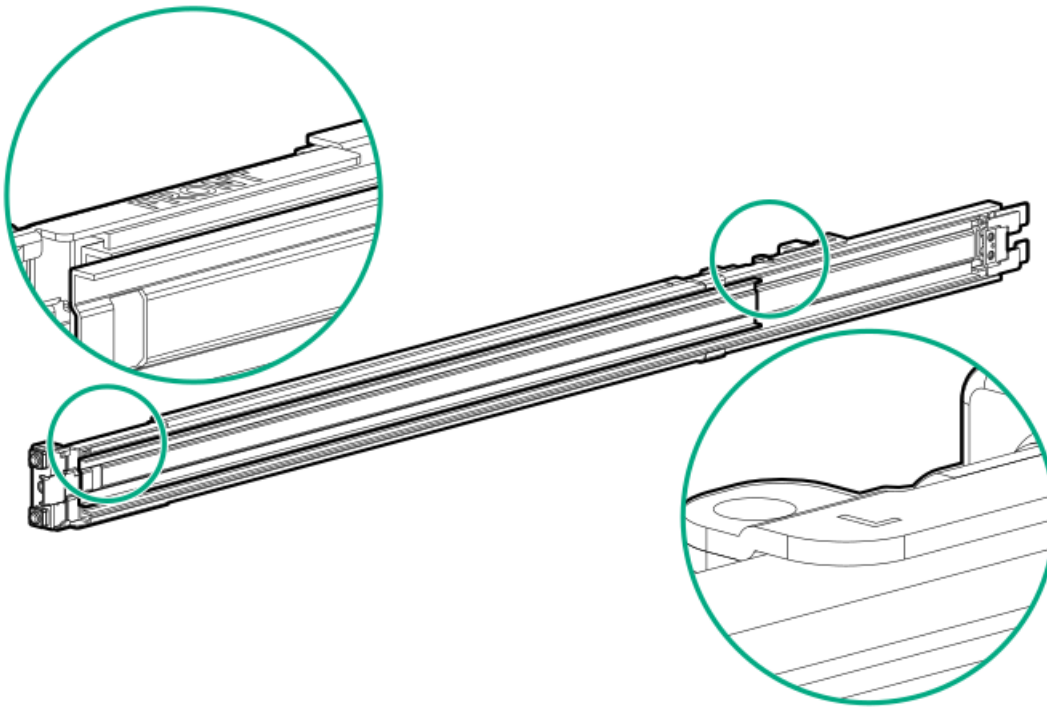

4. Fasten the mounting rails to the rack columns:

- a. Retract and hold the rear retention bracket.
- b. Insert the pins on the mounting flange into the rack column holes.
- c. Release the rear retention bracket.

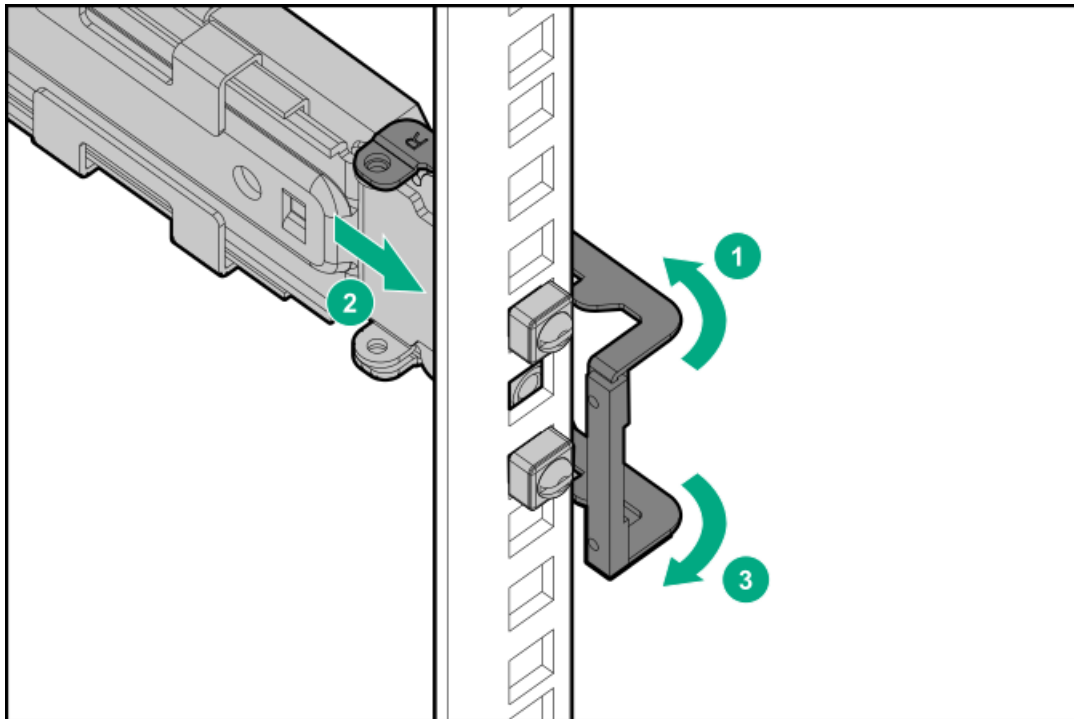

- d. Retract and hold the front retention bracket.
- e. Insert the pins on the mounting flange into the rack column holes.
- f. Release the front retention bracket.



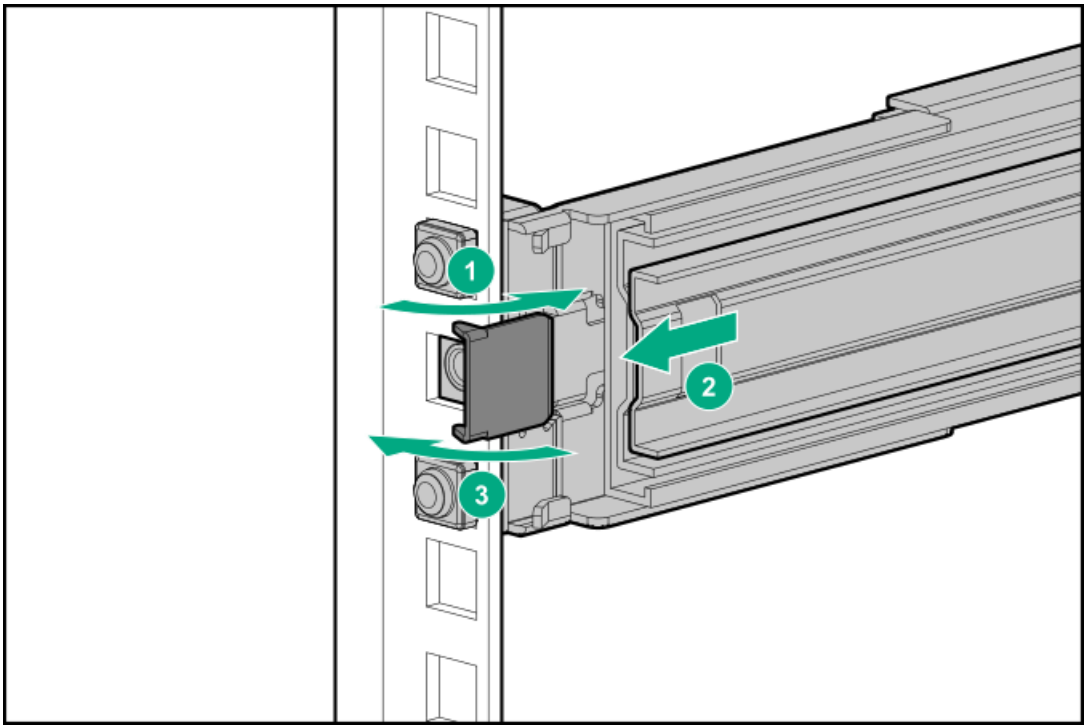

5. Extend the inner rail.

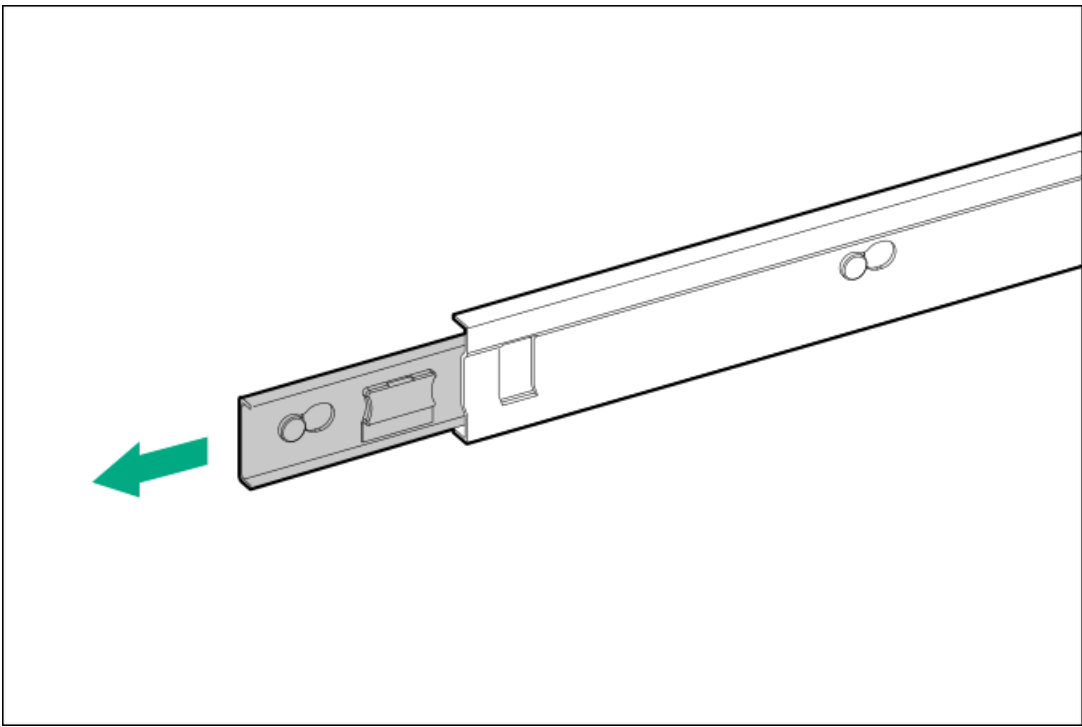

6. Slide the server tray into the rack.

The rack rails will click and lock into place when the tray is properly engaged.

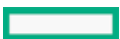

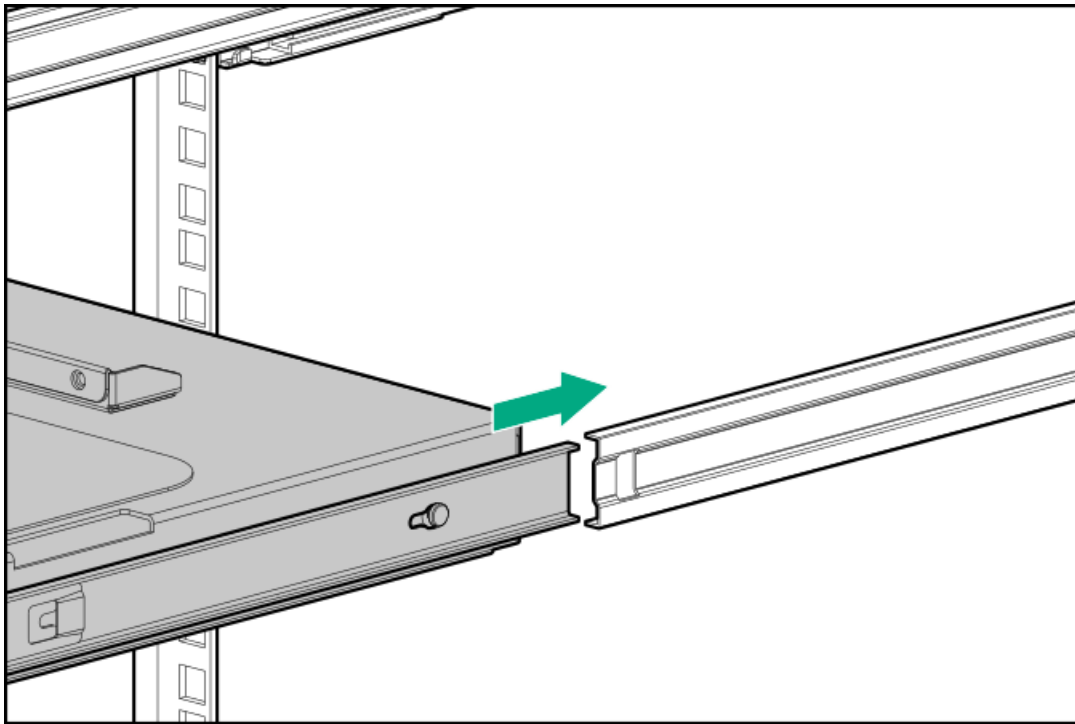

7. Install the server into the rack.

Install the server into the rack

Prerequisites

- Get help to lift and stabilize the server during rack installation. **If the server is installed higher than chest level, an additional two people might be required to help install the server:** One person to support the server weight, and the other two to slide the server into the rack.
- Before you perform this procedure, review the:
 - [Space and airflow requirements](#)
 - [Rack warnings and cautions](#)
 - [Server warnings and cautions](#)
- A fully populated server is heavy. Hewlett Packard Enterprise recommends removing the external chassis components before installing the server into a rack.
- Before you perform this procedure, make sure that you have a T-15 Torx screwdriver available.

Procedure

1. Grasp the tray notch to slide the tray out of the rack.

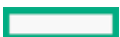

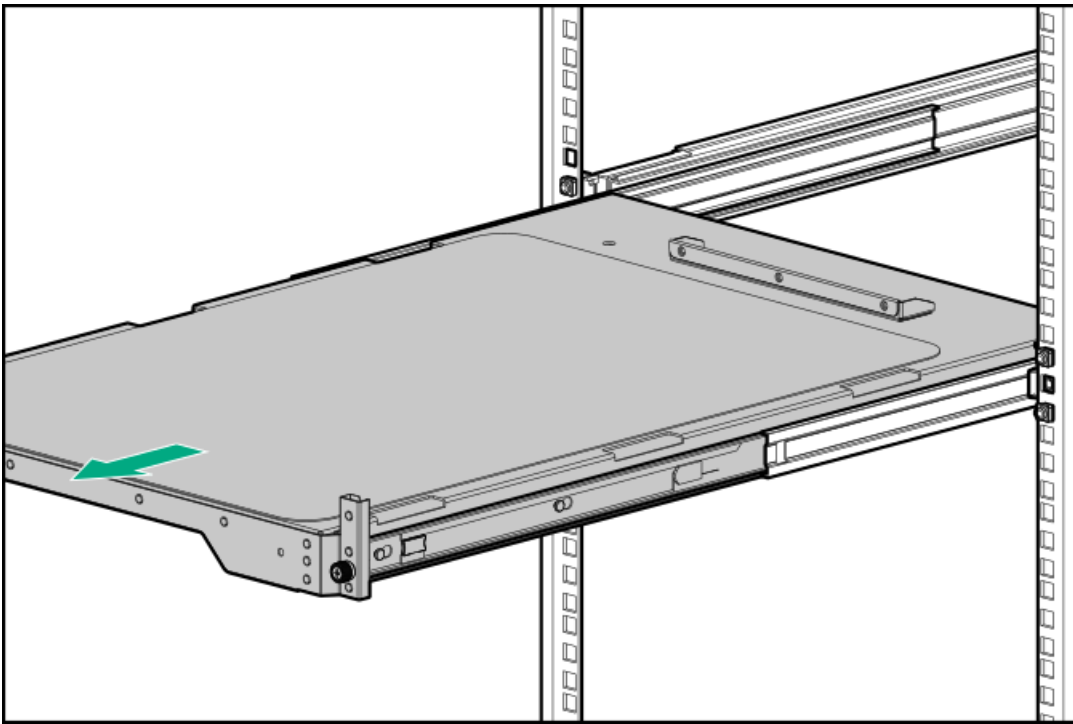

2. Place the server on the tray.

Verify that the front panel of the server is aligned with the front of the tray.

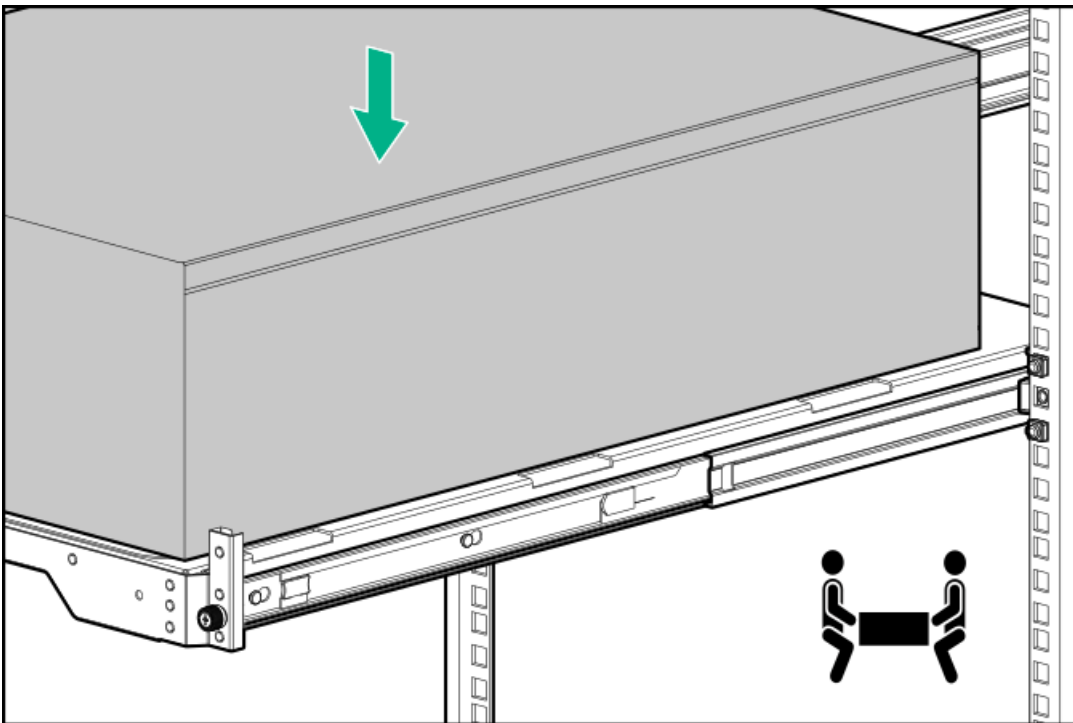

3. Install the chassis rear bracket screws.



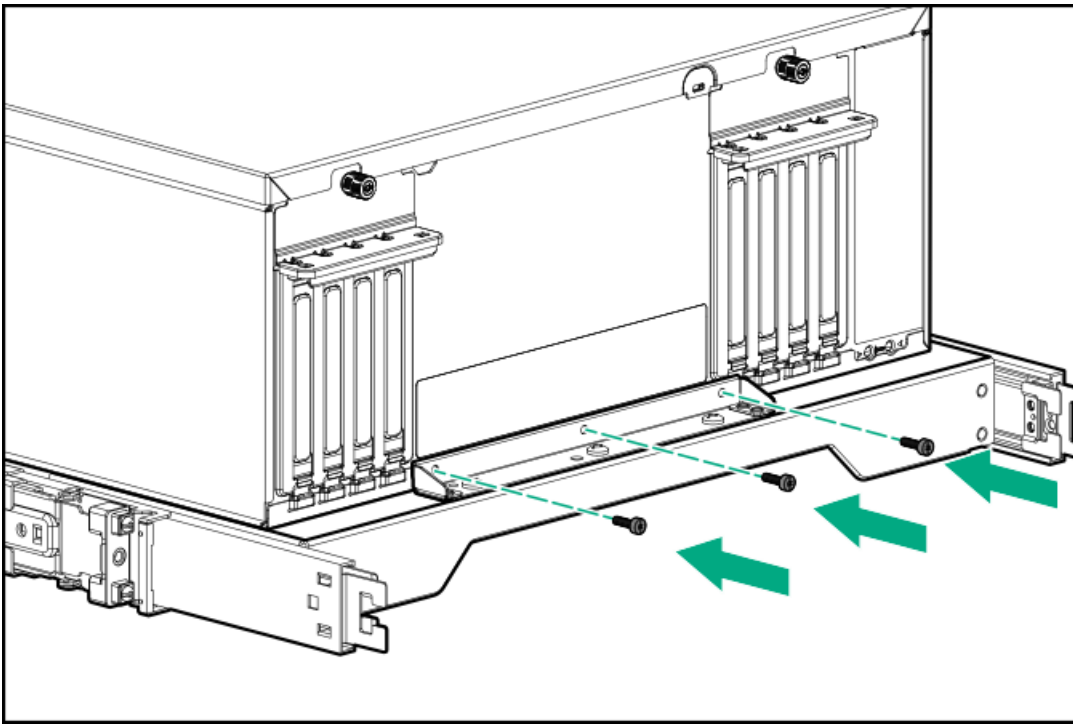

4. Press and hold the blue rail-release tabs, and then slide the tray back into the rack.

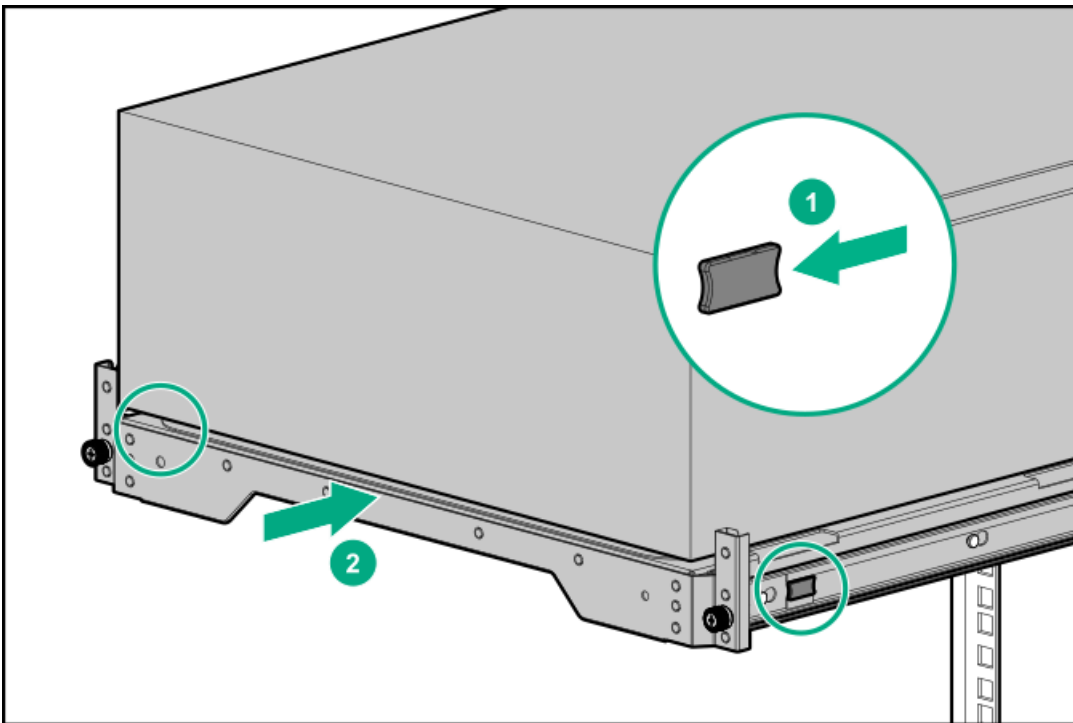

5. Connect all peripheral cables to the server.
6. Connect each power cord to the server.
7. Secure the power cord in the strain relief strap attached to the power supply handle:
 - a. Unwrap the strain relief strap from the power supply handle.

CAUTION: Avoid tight bend radii to prevent damaging the internal wires of a power cord or a server cable. Never bend power cords and server cables tight enough to cause a crease in the sheathing.

- b. Secure the power cord with the strain relief strap. Roll the extra length of the strap around the power supply handle.



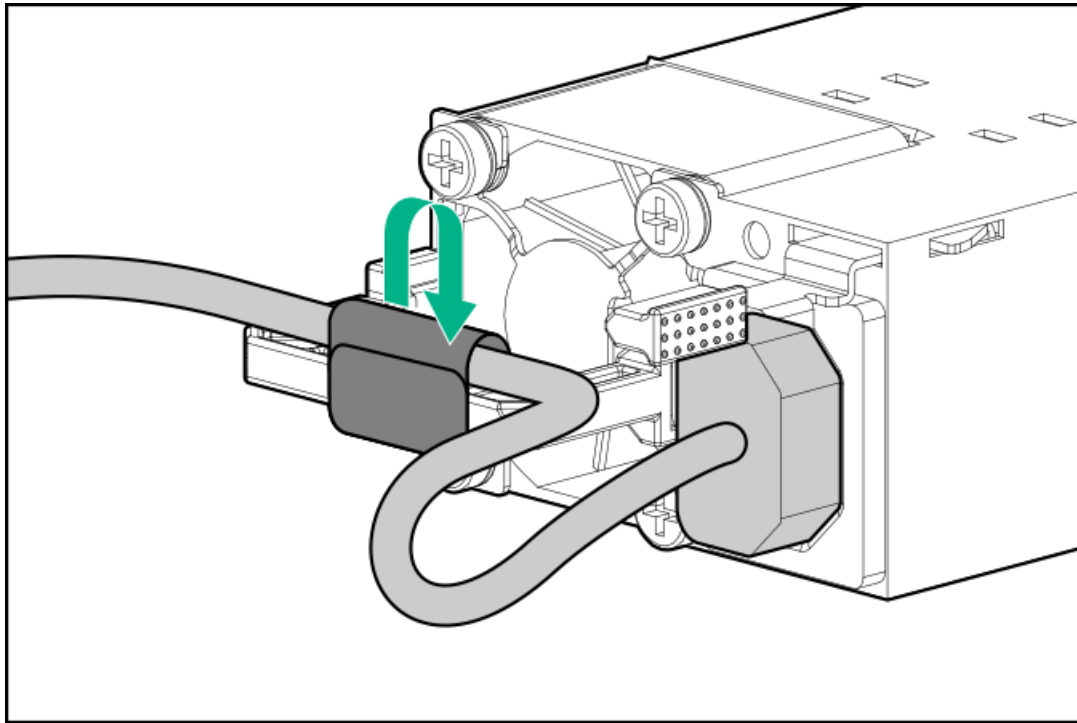

8. Install the cable management arm.

Install the cable management arm

About this task

The cable management arm (CMA) allows the server to be fully extended from the rack without the need to power off the system or disconnect any rear panel cables. This CMA is designed for ambidextrous implementation.

For the purpose of this procedure, left and right terminology is from the perspective of a user facing the front of the rack.

CAUTION:

Support the CMA during the removal and replacement procedures. Do not allow the CMA to hang by its own weight during the procedure.

Procedure

1. (Optional) The CMA retention bracket can be rotated to fit a left- or right-hand CMA operation. Press and hold the rotate mechanism, and then rotate the bracket 180°.

There will be an audible click to indicate that the bracket is locked in its adjusted position.

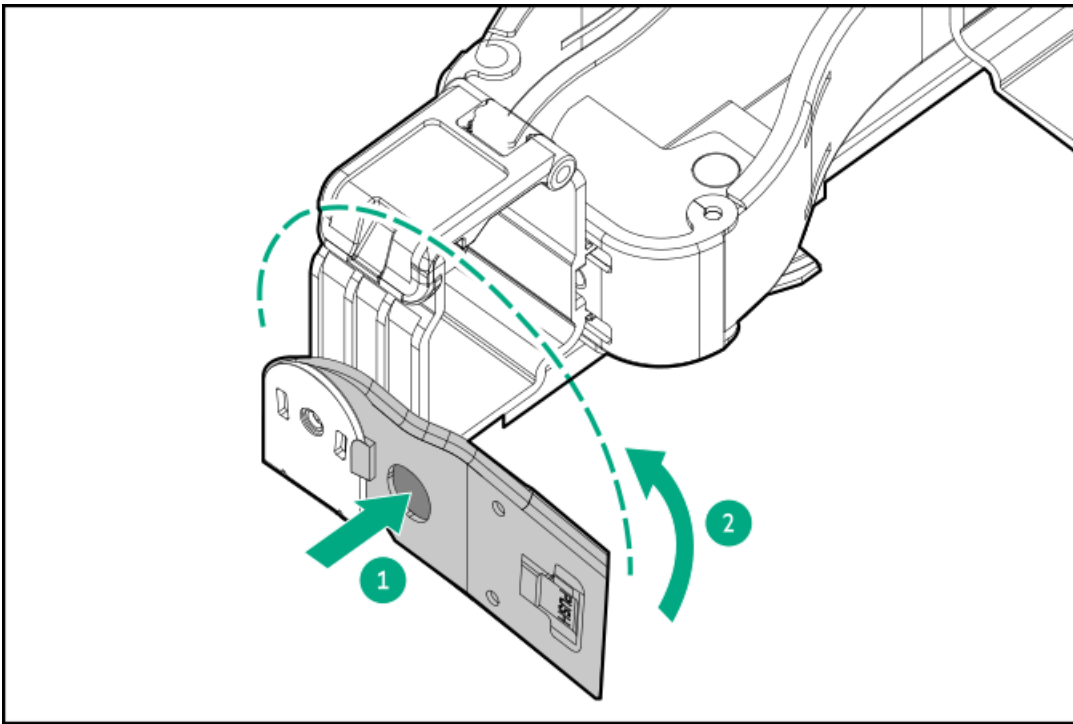

2. Connect the CMA hinged tabs and retention bracket to the rack rails:

- a. Insert the inner tab into the slide rail.
- b. Insert the outer tab into the mounting rail.
- c. Insert the retention bracket into the opposite mounting rail.

There will be an audible click to indicate that the tabs and bracket are locked into place.

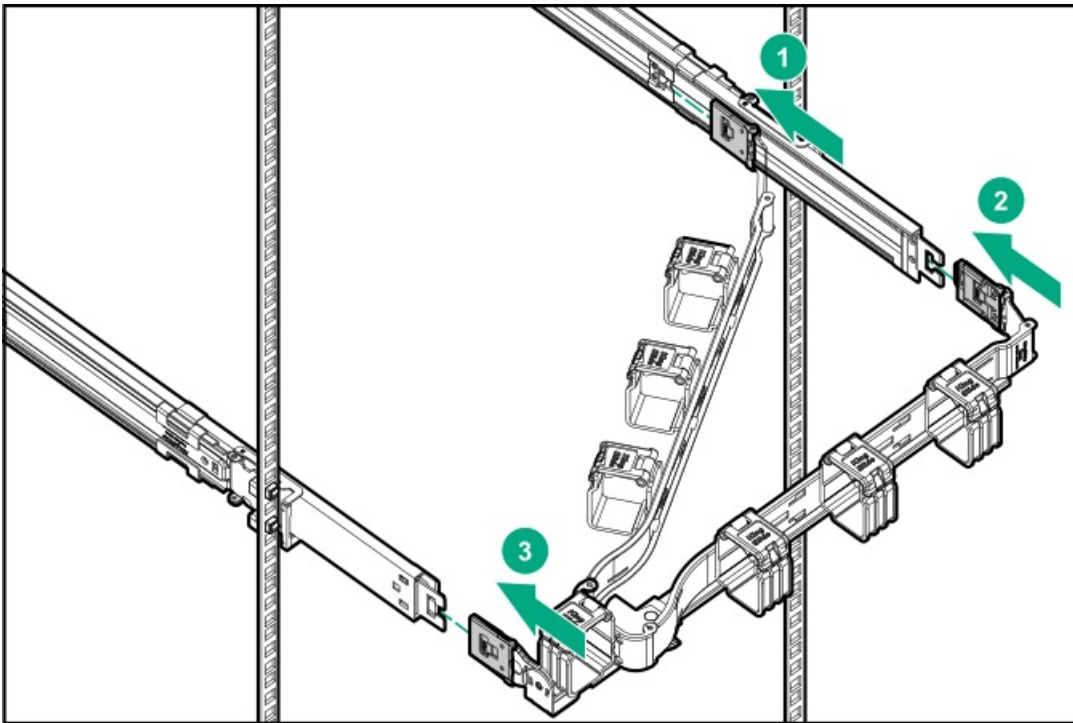

3. Open the cable clamps.



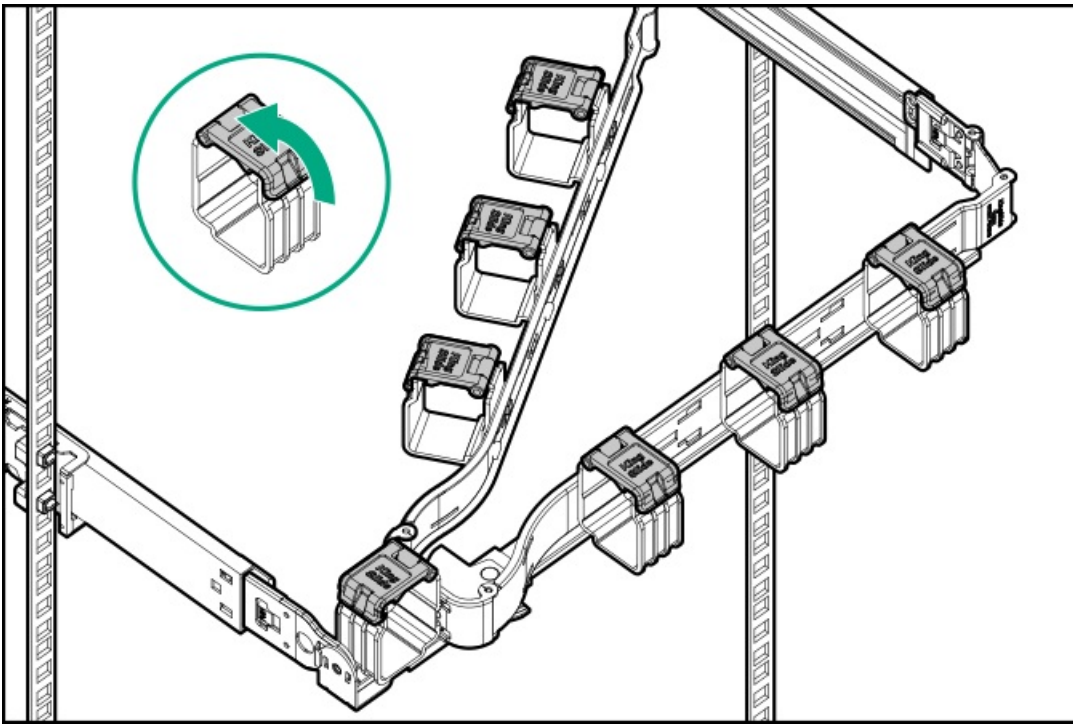

4. **CAUTION:** Employ industry best practices in managing peripheral cables and power cords secured in the CMA. These are some of the more important points:
- Leave enough cable slack between the rear panel and the CMA to allow the full extension of the CMA when the server is extended out of the rack.
 - However, there should be no excess cable slack inside the CMA; this might cause cable binding and could lead to cable damage.
 - Make sure that the cables and power cords do not extend above the top or below the bottom of the server to which they are attached. Otherwise, the cables might snag on other equipment installed in the rack when the server is extended from or returned to the rack.

Route the peripheral cables and power cords through the cable clamps.

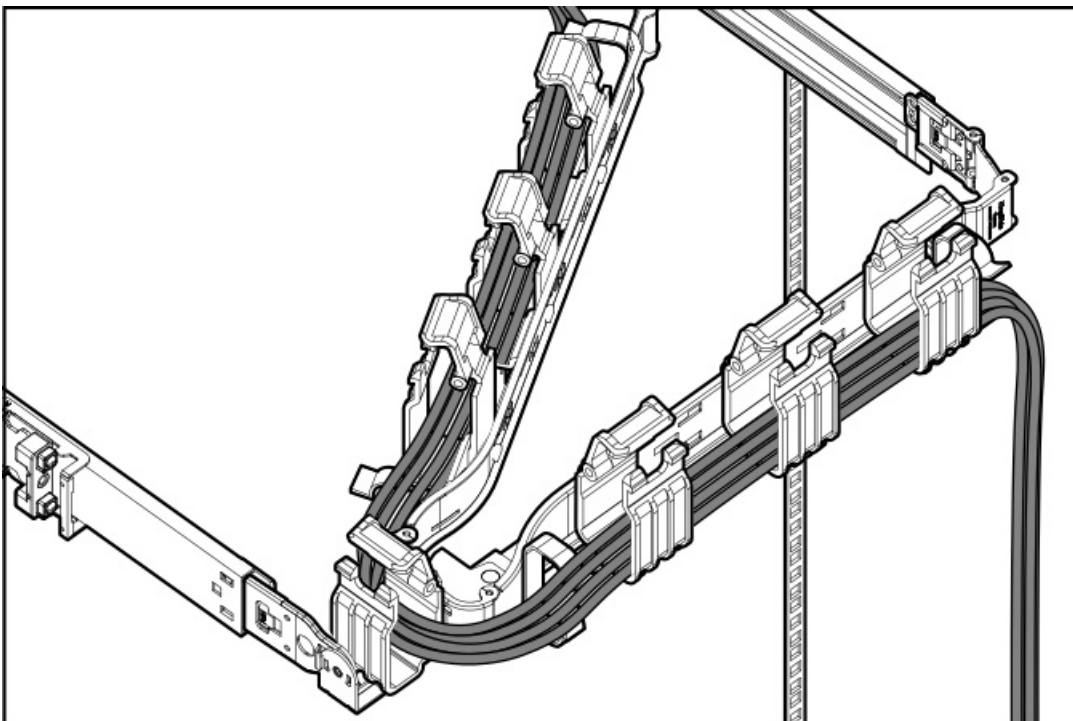

5. Close the cable clamps.

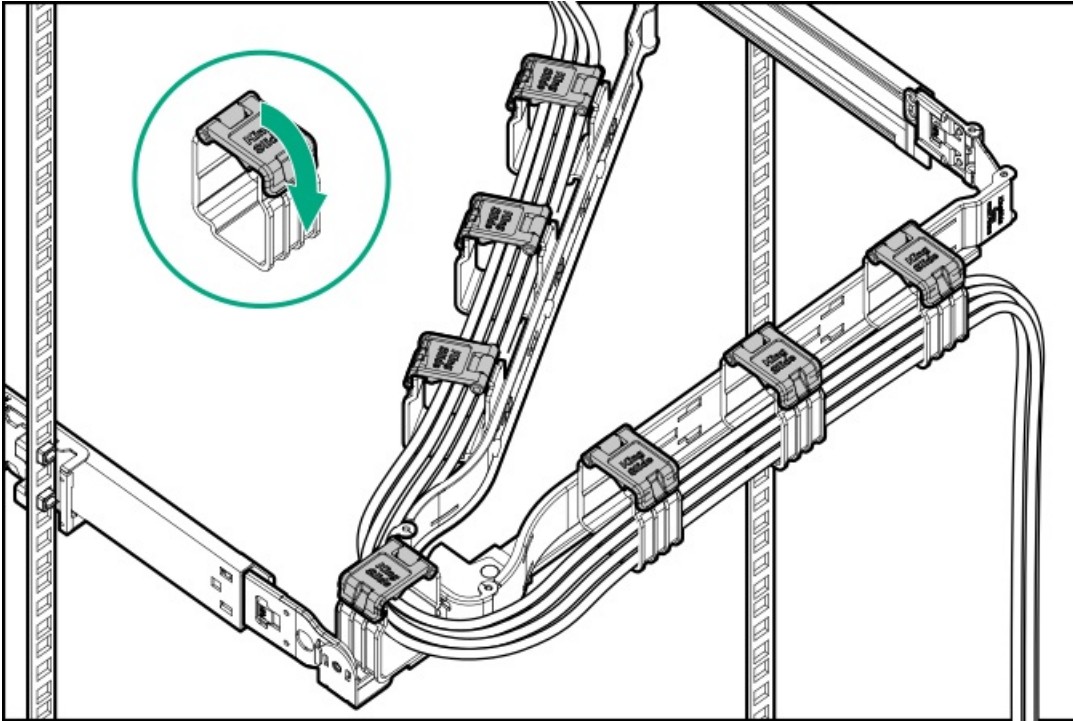

6. Verify that the peripheral cables and power cords are secured properly.

Two people is needed for this procedure: one to slide the server in and out of the rack, and the other to observe the peripheral cables and power cords.

- a. Fully extend the server tray out of the rack.
- b. Make sure that there is enough slack in the cables and cords for a full extension of the rack rails.

Make sure that there is no cable binding or crimping.

- c. Slide the server tray in and out of the rack to verify that there is no risk of accidental disconnection of the peripheral cables and power cords.

7. Tighten the server tray thumbscrews.



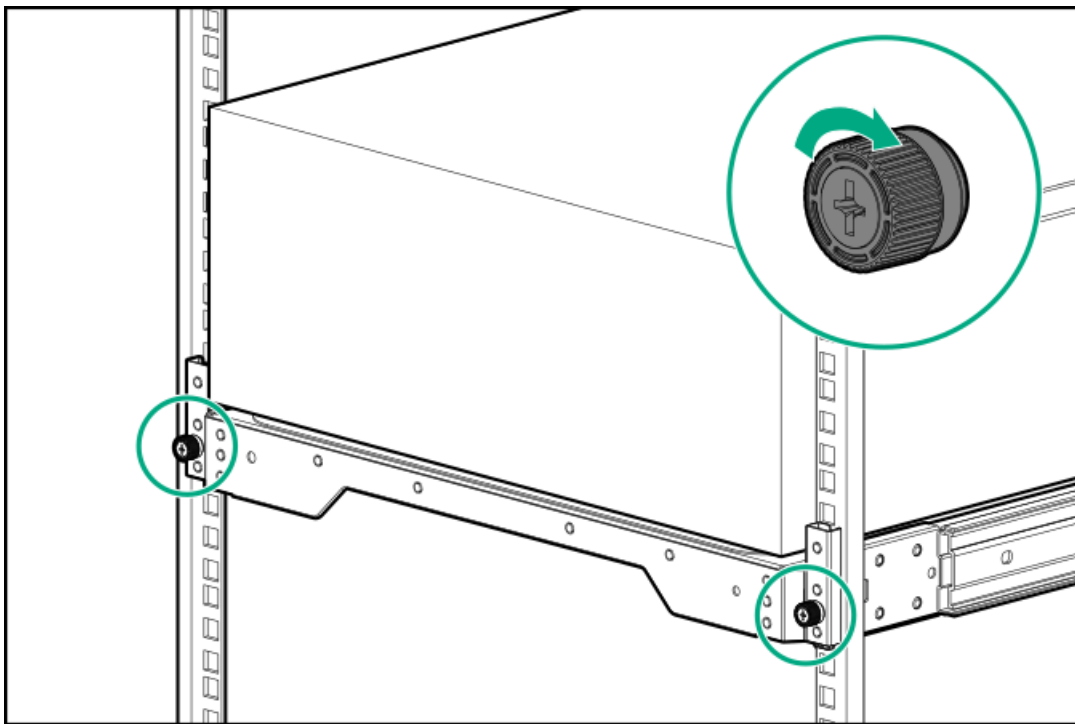

8. Connect each power cord to the power source.
9. Power up the server.

Results

The installation is complete.

Drive options

Depending on the drive backplane installed, the server supports the following drive types:

- Hot-plug LFF SAS and SATA drives
- Hot-plug SFF SAS, SATA, and U.3 PCIe4 NVMe drives
- Hot-plug E3.S PCIe5 NVMe SSDs

The embedded Intel VROC for HPE Gen11 (Intel VROC) supports software RAID for direct attached SATA and NVMe drives.

To support hardware RAID, install a storage controller option.

Subtopics

[Drive installation guidelines](#)

[Installing a hot-plug LFF/SFF drive](#)

[Installing a hot-plug E3.S drive](#)

Drive installation guidelines

Observe the following general guidelines:

- The system automatically sets all drive numbers.



△ CAUTION:

When a server is purchased without any drive installed, some drive bays might be empty while other drive bays might be populated with drive blanks. To maintain proper system cooling, do not operate the server without a drive or a drive blank installed.

- If only one drive is used, install it in the bay with the lowest drive number.
For drive numbering, see [Drive bay numbering](#).
- This server does not support mixed drive types in the same drive box.
- When installing NVMe drives, install all U.3 drives. Mixed NVMe type installation is not supported.
- All drives grouped into the same drive array must meet the following criteria:
 - They must be either all hard drives or all solid-state drives.
 - Drives must be the same capacity to provide the greatest storage space efficiency.

Installing a hot-plug LFF/SFF drive

About this task

△ CAUTION: A discharge of static electricity from a finger or other conductor might damage system boards or other static-sensitive devices. To prevent damage, observe [antistatic precautions](#).

△ CAUTION: To prevent improper cooling and thermal damage, do not operate the server unless all bays are populated with either a component or a blank.

Procedure

1. Open the front bezel:
 - a. Unlock the front bezel.
 - b. Open the front bezel.

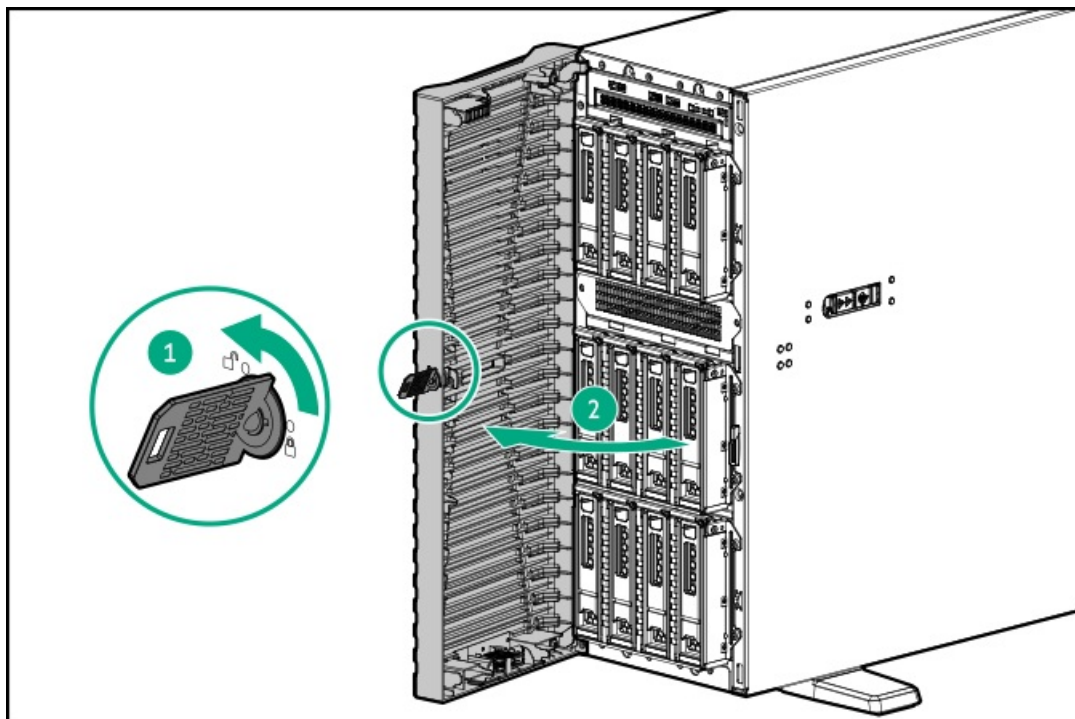

2. Remove the drive blank.

- LFF drive blank

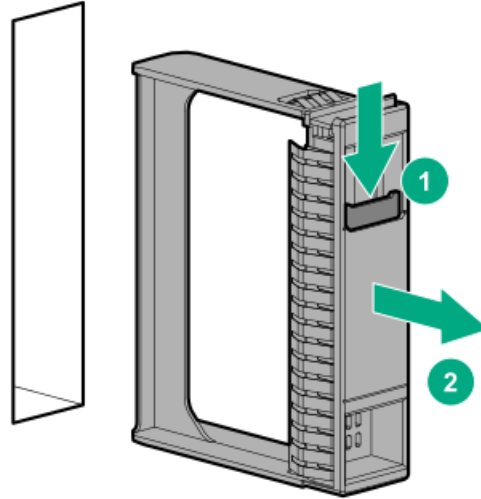

- SFF drive blank

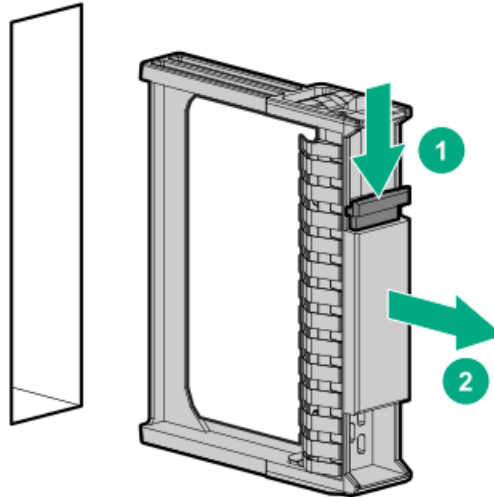

- E3.S drive blank



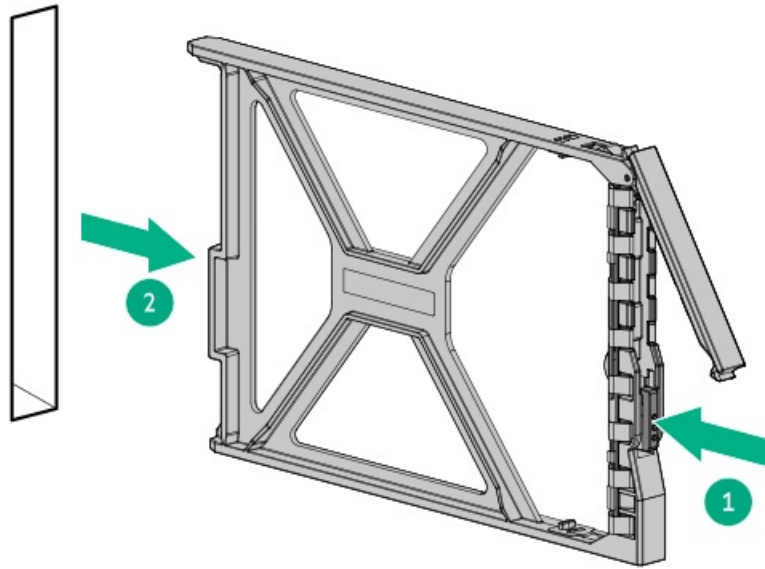

3. Prepare the drive.

- LFF drive

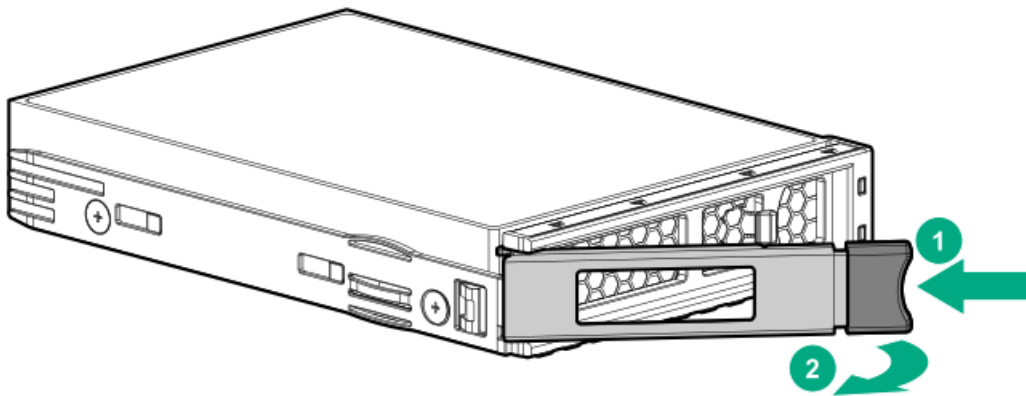

- SFF drive

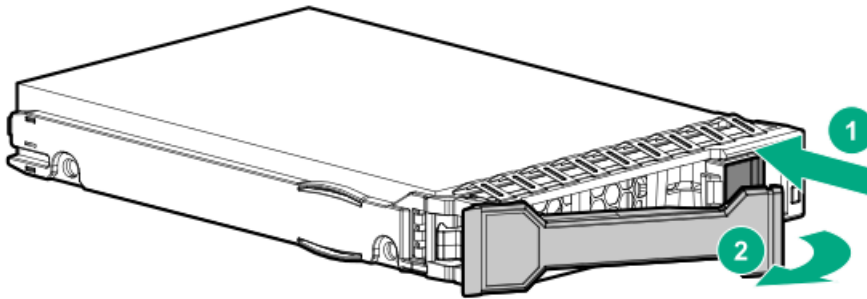

4. Install the drive.

- LFF drive



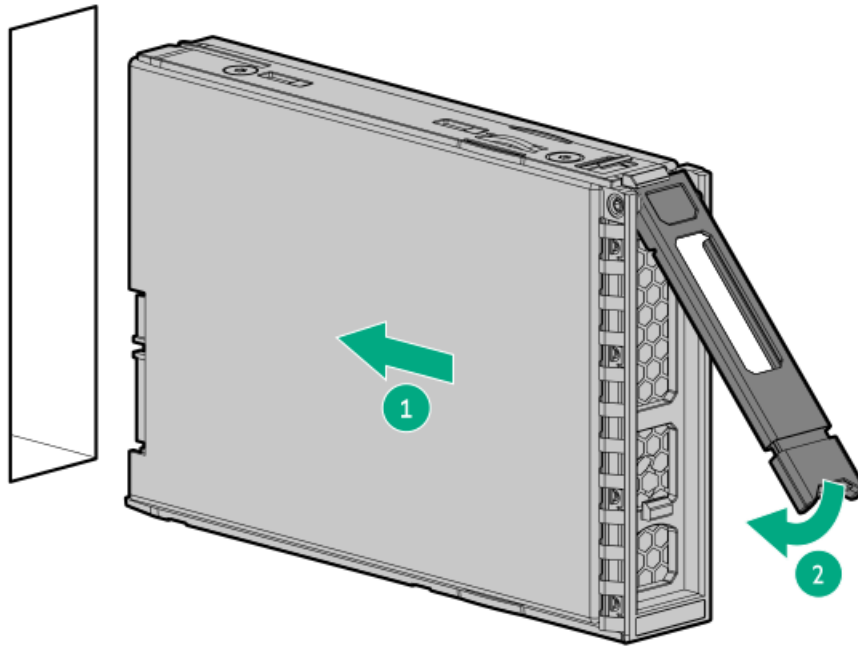

- SFF drive

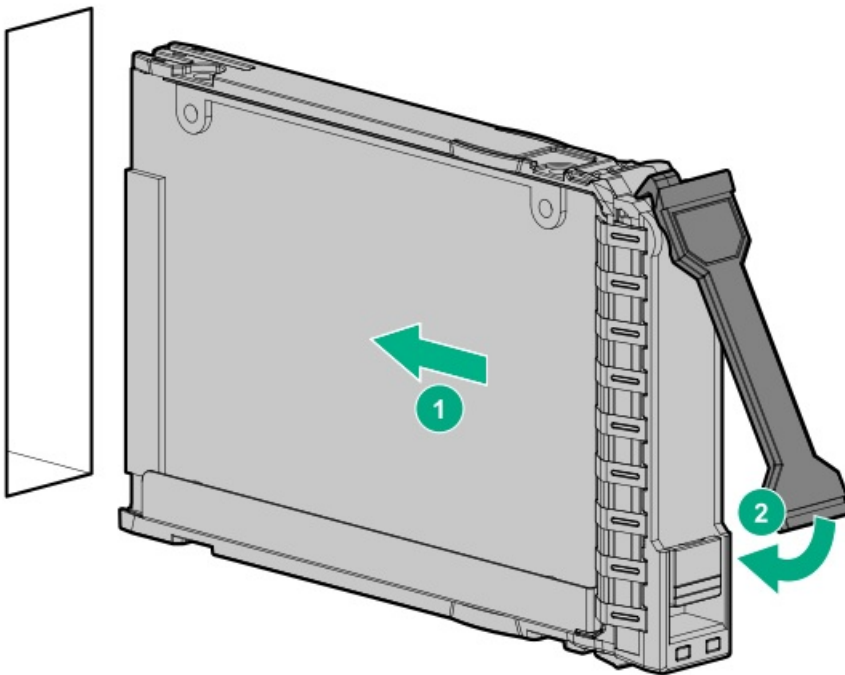

5. Determine the status of the drive from the drive LED definitions.
6. Close the front bezel:
 - a. Close the front bezel.
 - b. Lock the front bezel.



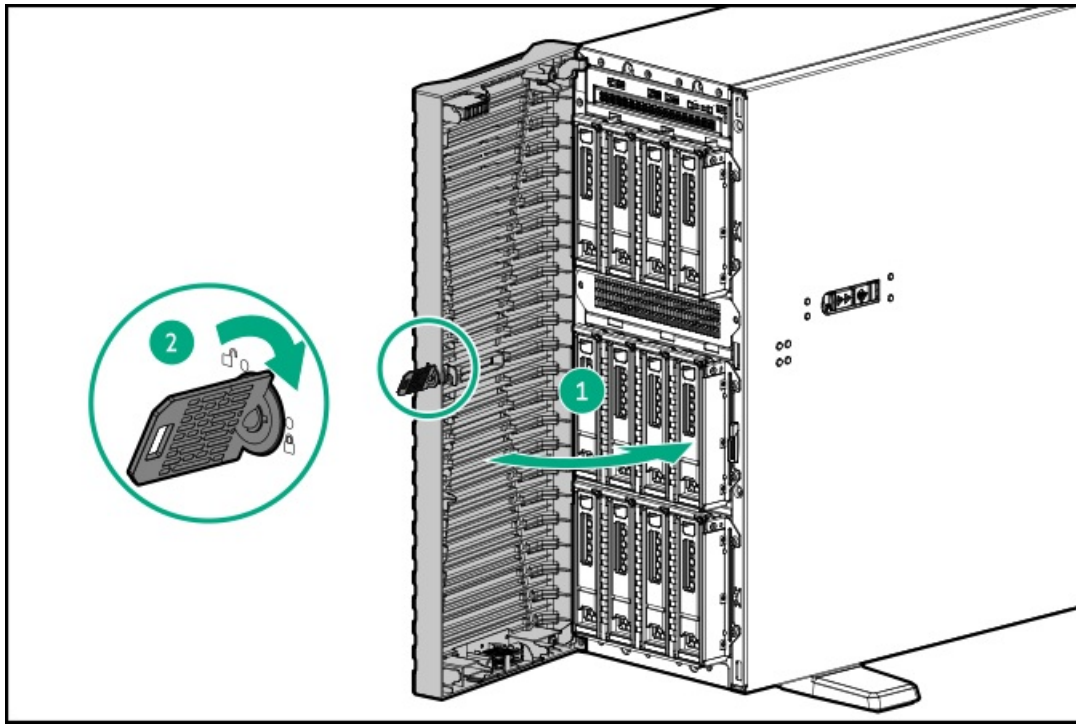

7. To configure drive arrays, see the [relevant storage controller guide](#).

Results

The installation is complete.

Installing a hot-plug E3.S drive

Prerequisites

Before performing this procedure, review the [Limited operating inlet ambient temperature requirements for E3.S drive configuration](#).

About this task

CAUTION: A discharge of static electricity from a finger or other conductor might damage system boards or other static-sensitive devices. To prevent damage, observe [antistatic precautions](#).

CAUTION: To prevent improper cooling and thermal damage, do not operate the server unless all bays are populated with either a component or a blank.

Procedure

1. Open the front bezel:
 - a. Unlock the front bezel.
 - b. Open the front bezel.

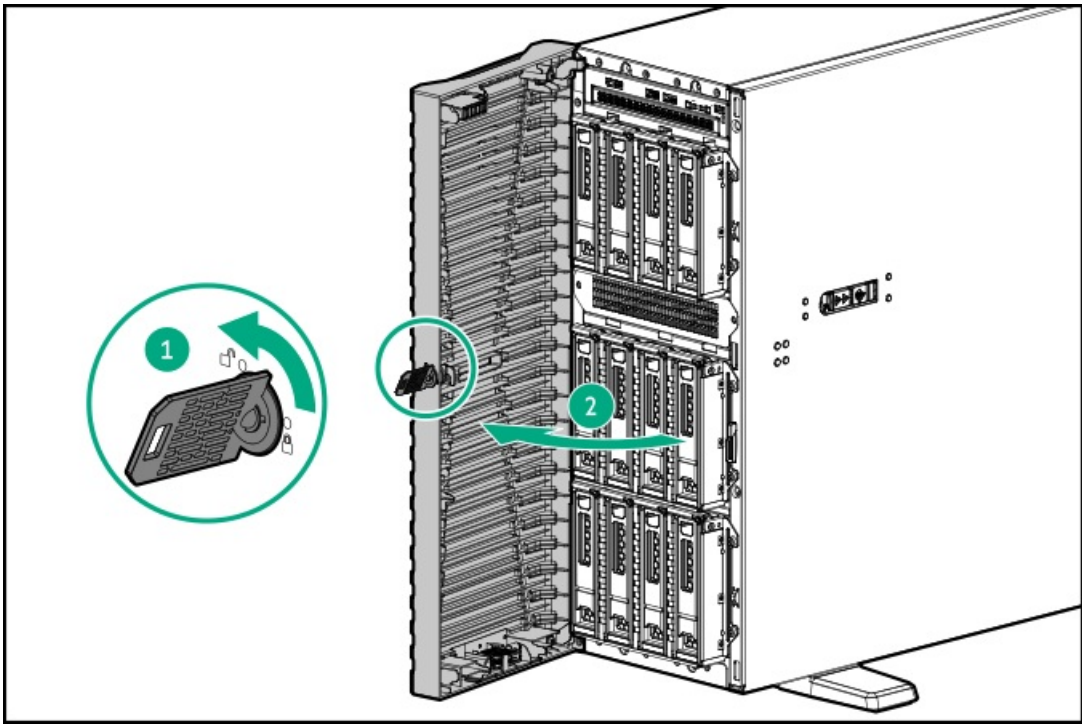

2. Remove the drive blank.

Retain the blank for future use.

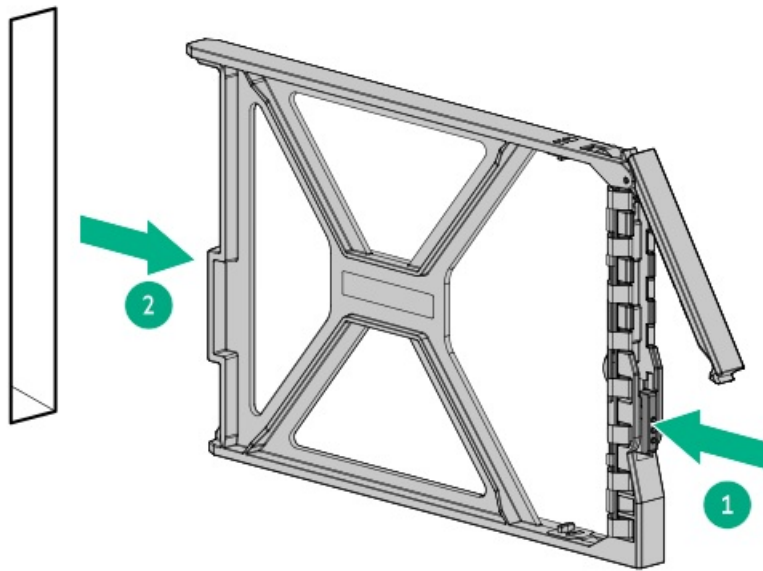

3. Prepare the drive.



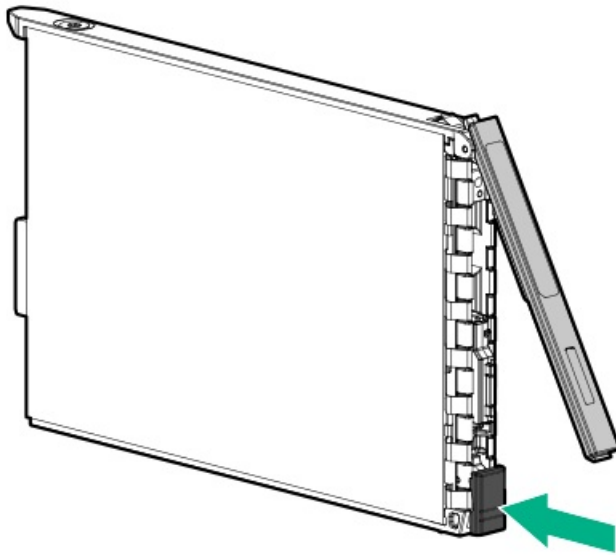

4. Install the drive.

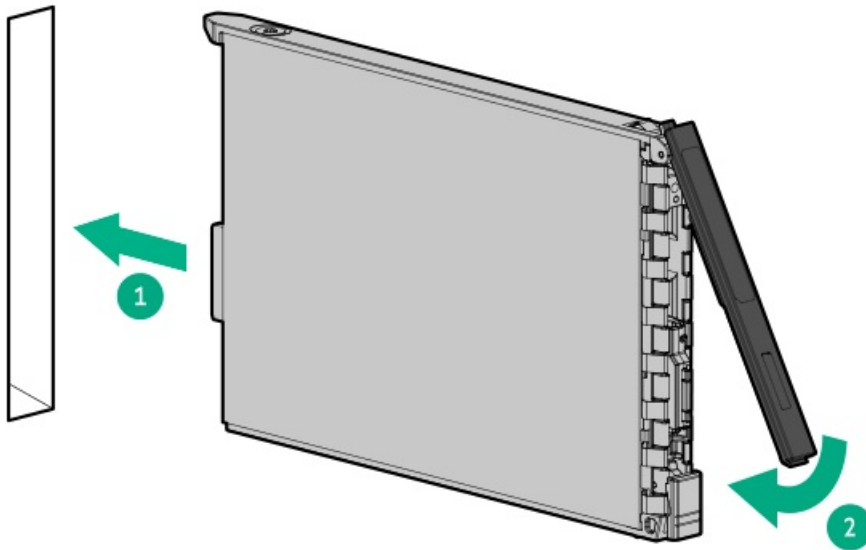

5. Determine the status of the drive from the drive LED definitions .

6. Close the front bezel:

- a. Close the front bezel.
- b. Lock the front bezel.



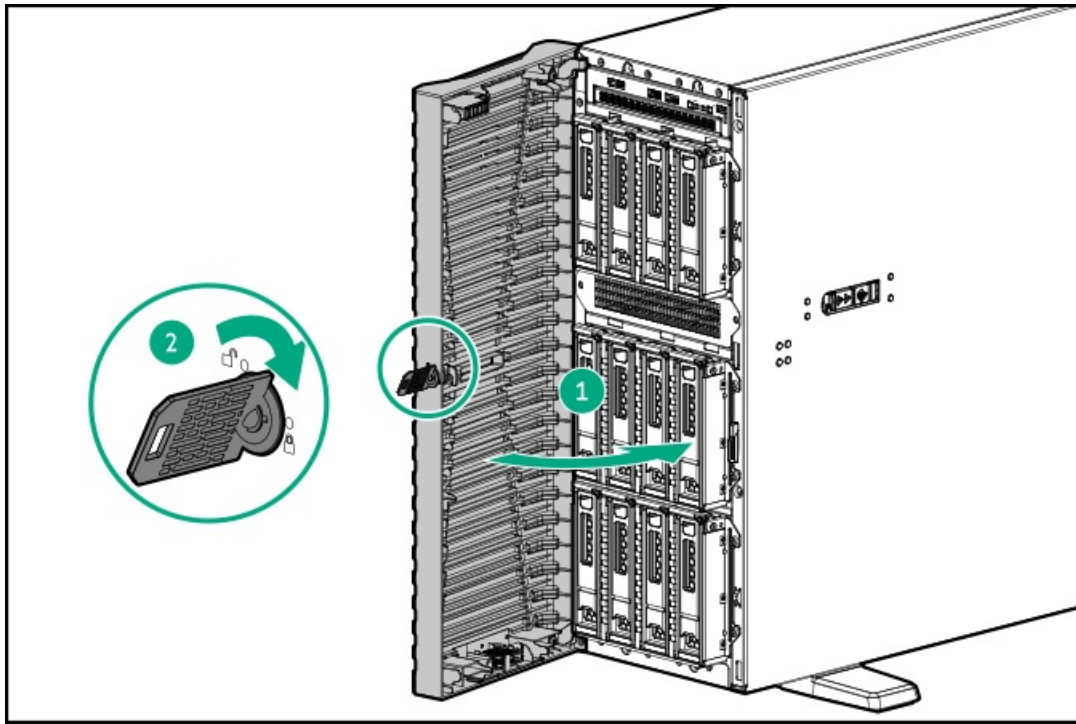

7. To configure drive arrays, see the [relevant storage controller guide](#).

Results

The installation is complete.

Power supply options

Depending on the installed options and the regional location where the server was purchased, the server can be configured with one of the supported [power supplies](#).

Subtopics

[Hot-plug power supply calculations](#)

[Power supply warnings and cautions](#)

[DC power supply warnings and cautions](#)

[DC power supply wire colors](#)

[Installing an AC power supply](#)

[Installing a DC power supply](#)

[Connecting a DC power cable to a DC power source](#)

Hot-plug power supply calculations

For hot-plug power supply specifications and calculators to determine electrical and heat loading for the server, see the Hewlett Packard Enterprise Power Advisor website (<https://www.hpe.com/info/poweradvisor/online>).

Power supply warnings and cautions



WARNING:

To reduce the risk of electric shock or damage to the equipment:

- Do not disable the power cord grounding plug. The grounding plug is an important safety feature.
 - Plug the power cord into a grounded (earthed) electrical outlet that is easily accessible at all times.
 - Unplug the power cord from the power supply to disconnect power to the equipment.
 - Do not route the power cord where it can be walked on or pinched by items placed against it. Pay particular attention to the plug, electrical outlet, and the point where the cord extends from the server.
-



WARNING: To reduce the risk of injury from electric shock hazards, do not open power supplies. Refer all maintenance, upgrades, and servicing to qualified personnel.



CAUTION: Mixing different types of power supplies in the same server might:

- Limit or disable some power supply features including support for power redundancy.
- Cause the system to become unstable and might shut down.

To ensure access to all available features, all power supplies in the same server should have the same output and efficiency ratings. Verify that all power supplies have the same part number and label color.

DC power supply warnings and cautions



WARNING: To reduce the risk of electric shock, be sure that the cable grounding kit is properly installed and connected to a suitable protective earth terminal before connecting the power source to the rack.



CAUTION: This equipment is designed to permit the connection of the earthed conductor of the DC supply circuit to the earthing conductor at the equipment. If this connection is made, all the following must be met:

- This equipment must be connected directly to the DC supply system earthing electrode conductor or to a bonding jumper from an earthing terminal bar or bus to which the DC supply system earthing electrode conductor is connected.
 - This equipment must be located in the same immediate area (such as adjacent cabinets) as any other equipment that has a connection between the earthed conductor of the same DC supply circuit and the earthing conductor, and also the point of earthing of the DC system. The DC system must be earthed elsewhere.
 - The DC supply source is to be located within the same premises as the equipment.
 - Switching or disconnecting devices must not be in the earthed circuit conductor between the DC source and the point of connection of the earthing electrode conductor.
-

DC power supply wire colors

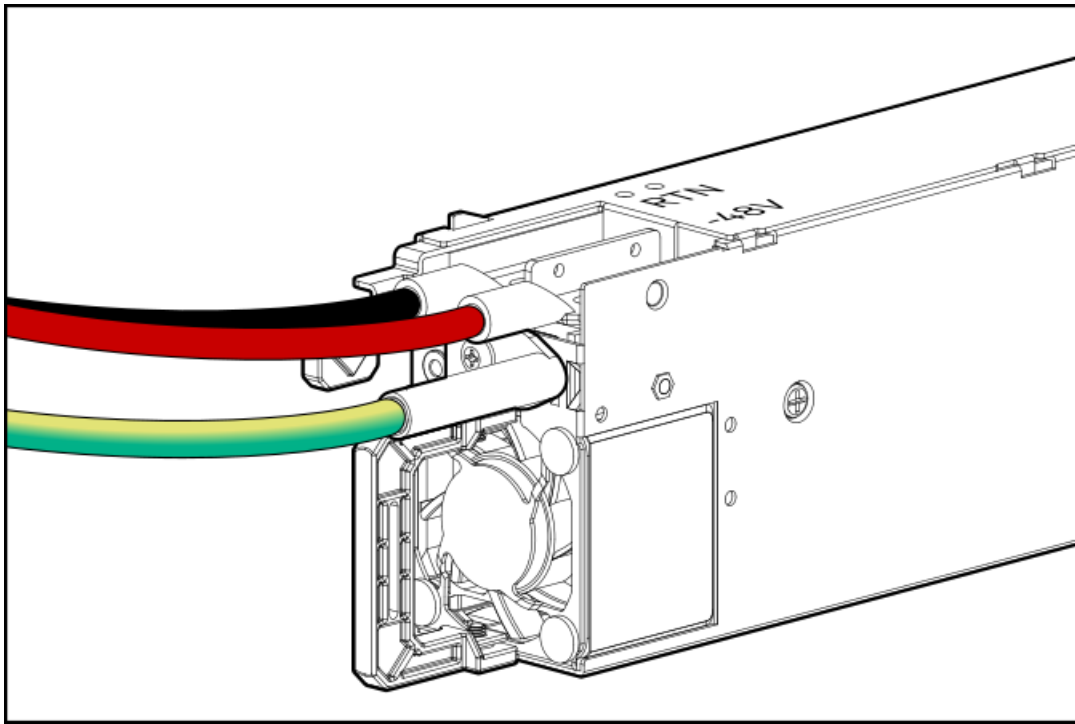

Wire color	Description	Wire slot
Red	Line wire	-48V
Black	Return wire	Return
Green + Yellow	Ground wire	Safety ground

Installing an AC power supply

Prerequisites

Before installing a power supply option, review the [Power supply warnings and cautions](#).

About this task

WARNING: To reduce the risk of personal injury from hot surfaces, allow the power supply, power supply blank, or dual slot power supply adapter to cool before touching it.

CAUTION: To prevent improper cooling and thermal damage, do not operate the server unless all bays are populated with either a component or a blank.

Procedure

1. If you are installing a power supply in the power supply bay 2, remove the power supply blank.

Retain the blank for future use.

- Tower mode

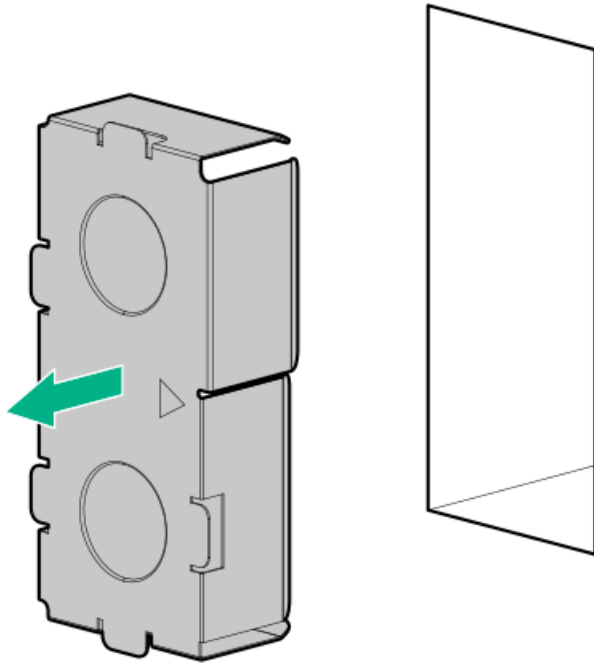

- Rack mode

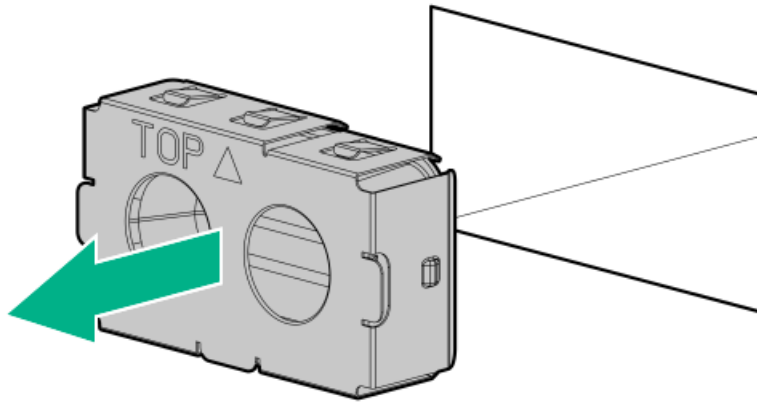

2. Immediately slide the power supply into the bay until it clicks into place.

- Tower mode

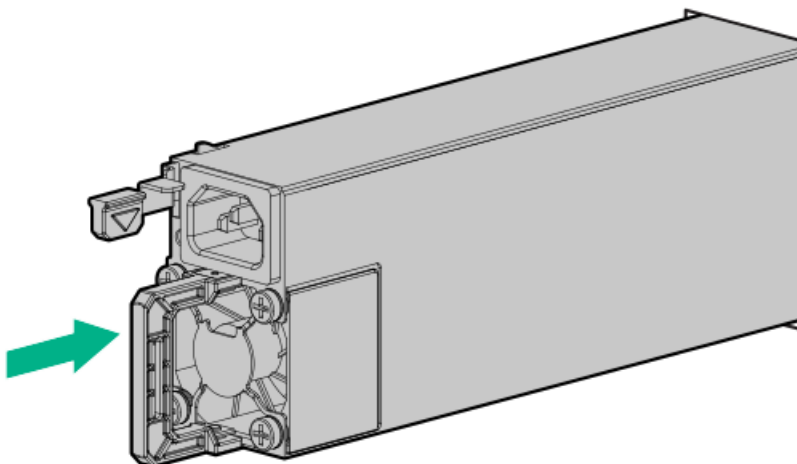

- Rack mode

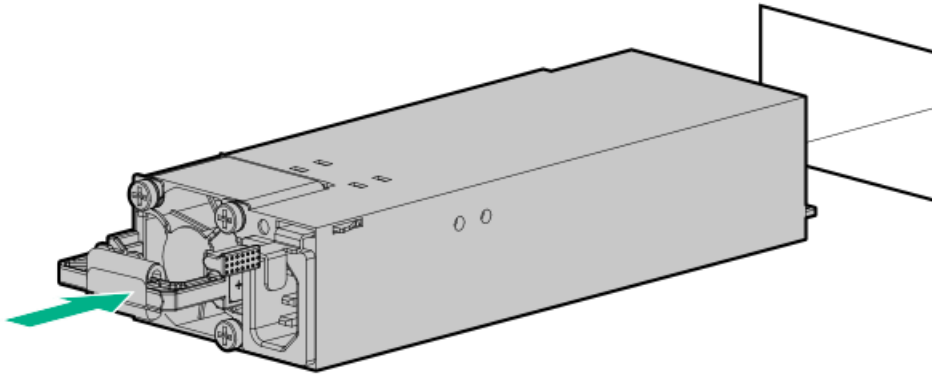

3. Connect the power cord to the power supply.
4. Secure the power cord in the strain relief strap attached to the power supply handle:
 - a. Unwrap the strain relief strap from the power supply handle.

CAUTION: Avoid tight bend radii to prevent damaging the internal wires of a power cord or a server cable. Never bend power cords and server cables tight enough to cause a crease in the sheathing.

- b. Secure the power cord with the strain relief strap. Roll the extra length of the strap around the power supply handle.

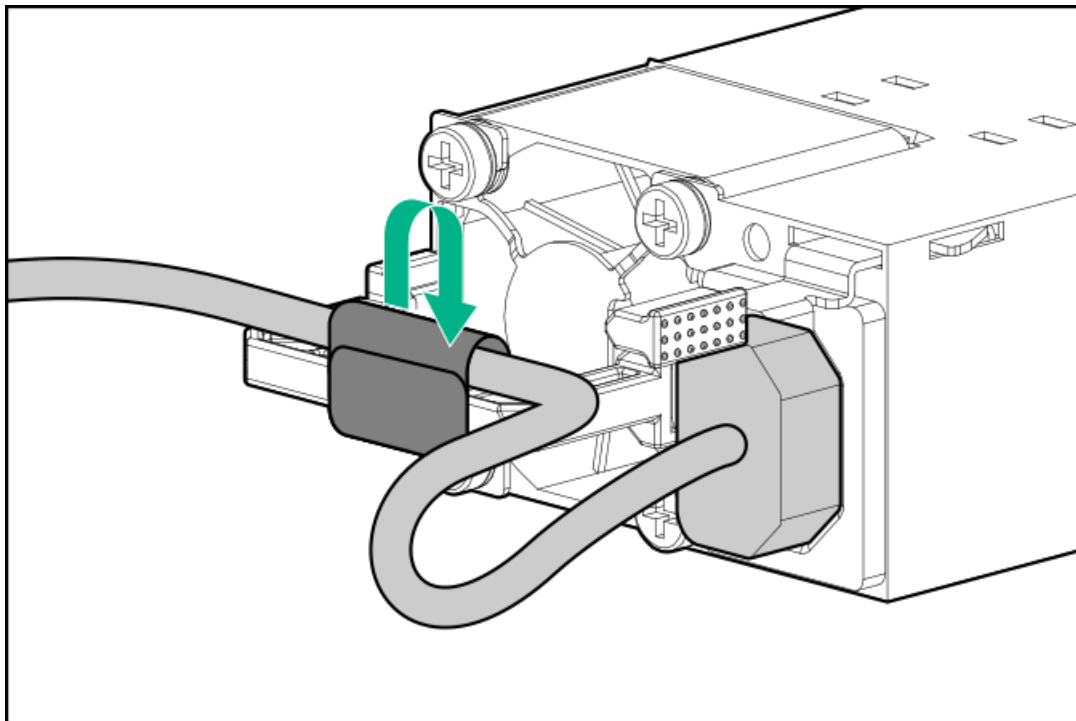

5. Connect the power cords:
 - a. Connect each power cord to the server.
 - b. Connect each power cord to the power source.
6. Make sure that the power supply LED is green.

Results



The installation is complete.

Installing a DC power supply

Prerequisites

- Before installing a power supply, review the following:
 - [Power supply warnings and cautions](#)
 - [DC power supply warnings and cautions](#)
 - [DC power supply wire colors](#)
- Before you perform this procedure, make sure that you have a Phillips No. 2 screwdriver available.
- Before connecting the power cables, review the following:
 - The optional P36877-B21 HPE lug kit can be purchased from an authorized HPE reseller for use with customer-supplied power cables. (The power cable and lug kit listed below can only be used with the 1600 W -48 VDC power supply.)
 - If you are using an input power cord option, the P22173-B21 HPE 1600 W DC PSU power cable kit can be purchased from an authorized HPE reseller.
 - The DC power supply option kits do not ship with a Power Supply DC cable Kit and may not include a Power Supply Cable Lug kit. The optional DC Cable kit or the optional DC Cable Lug Kit may be purchased directly from Hewlett Packard Enterprise or an authorized HPE reseller. For additional information, see the power supply QuickSpecs at <https://www.hpe.com/info/fsps-qs>.

About this task

If you are not using an input power cord option, the power supply cabling must be made in consultation with a licensed electrician and be compliant with local code.



WARNING:

To reduce the risk of electric shock, fire, and damage to the equipment, you must install this product in accordance with the following guidelines:

- The HPE 1600 W Flex Slot -48 VDC hot-plug power supply is intended only for installation in Hewlett Packard Enterprise servers located in a restricted access location.
 - The HPE 1600 W Flex Slot -48 VDC hot-plug power supply is not intended for direct connection to the DC supply branch circuit. Only connect this power supply to a power distribution unit (PDU) that provides an independent overcurrent-protected output for each DC power supply. Each output overcurrent-protected device in the PDU must be suitable for interrupting fault current available from the DC power source and must be rated no more than 45 A.
 - The PDU output must have a shut-off switch or a circuit breaker to disconnect power for each power supply. To completely remove power from the power supply, disconnect power at the PDU. The end product may have multiple power supplies. To remove all power from the product, disconnect the power for each power supply.
 - In accordance with applicable national requirements for Information Technology Equipment and Telecommunications Equipment, this power supply only connects to DC power sources that are classified as SELV or TNV. Generally, these requirements are based on the International Standard for Information Technology Equipment, IEC 60950-1/IEC 62368-1. In accordance with local and regional electric codes and regulations, the DC source must have one pole (Neutral/Return) reliably connected to earth ground.
 - You must connect the power supply ground screw located on the front of the power supply to a suitable ground (earth) terminal. In accordance with local and regional electric codes and regulations, this terminal must be connected to a suitable building ground (earth) terminal. Do not rely on the rack or cabinet chassis to provide adequate ground (earth) continuity.
-

WARNING: To reduce the risk of personal injury from hot surfaces, allow the power supply, power supply blank, or dual slot power supply adapter to cool before touching it.

CAUTION: To prevent improper cooling and thermal damage, do not operate the server unless all bays are populated with either a component or a blank.

Procedure

1. Remove the protective cover from the power supply.

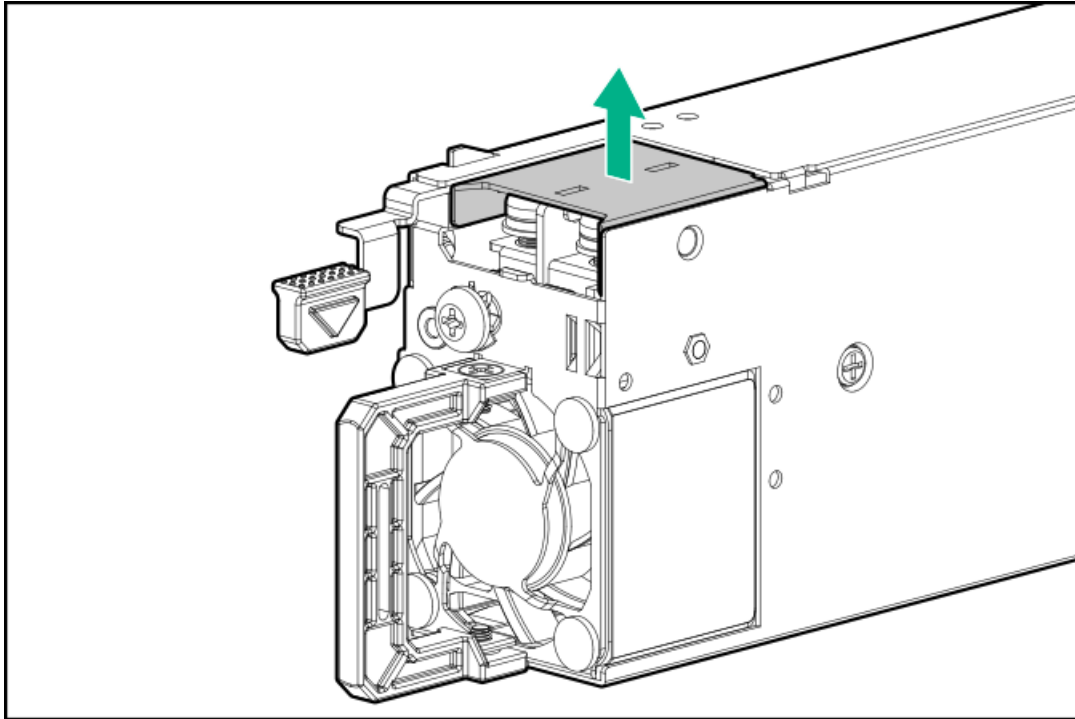

2. Remove the ground wire screw, and then remove the return wire and line wire screws.

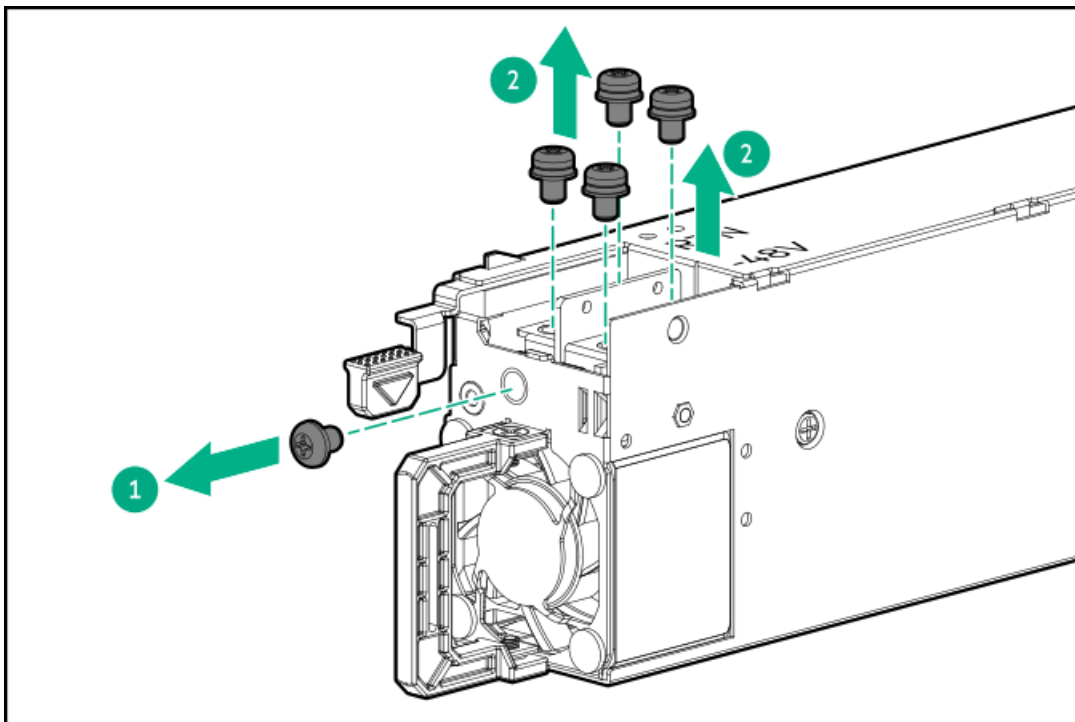

3. Attach the ground wire (green and yellow) to the DC power supply and tighten the screw and washer with 1.47 N-m (13 lbf-in).



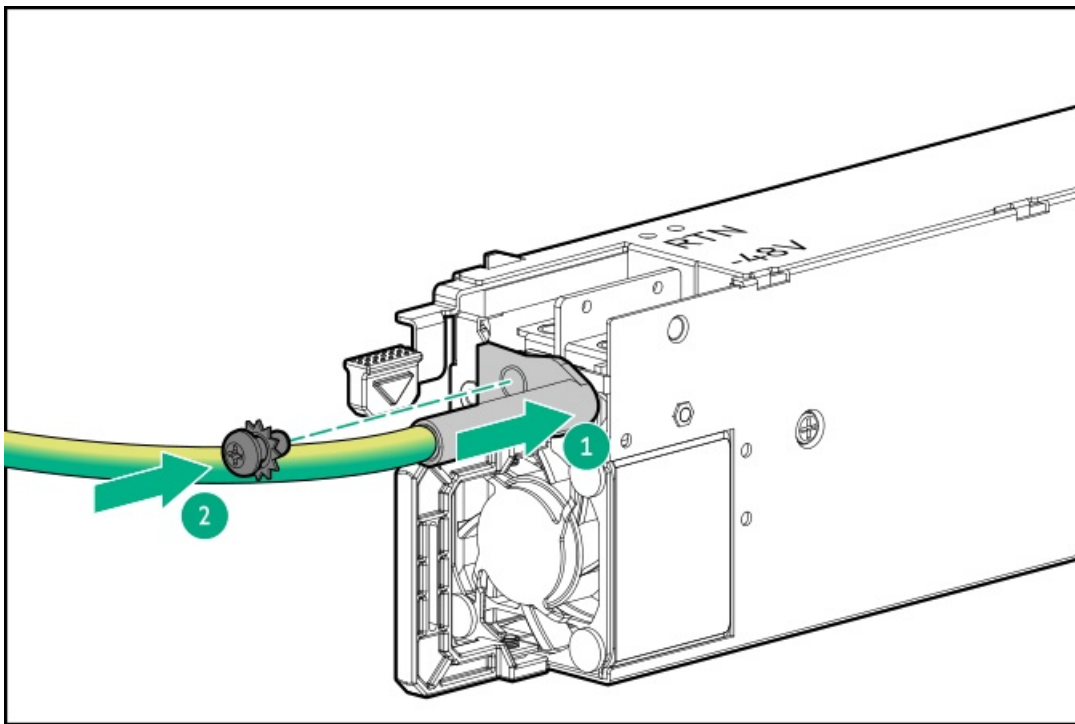

4. Install the return wire (black):

- a. Insert the return wire into the RTN slot on the DC power supply.
- b. Tighten the screw with 0.98 N-m (8.68 lbf-in).

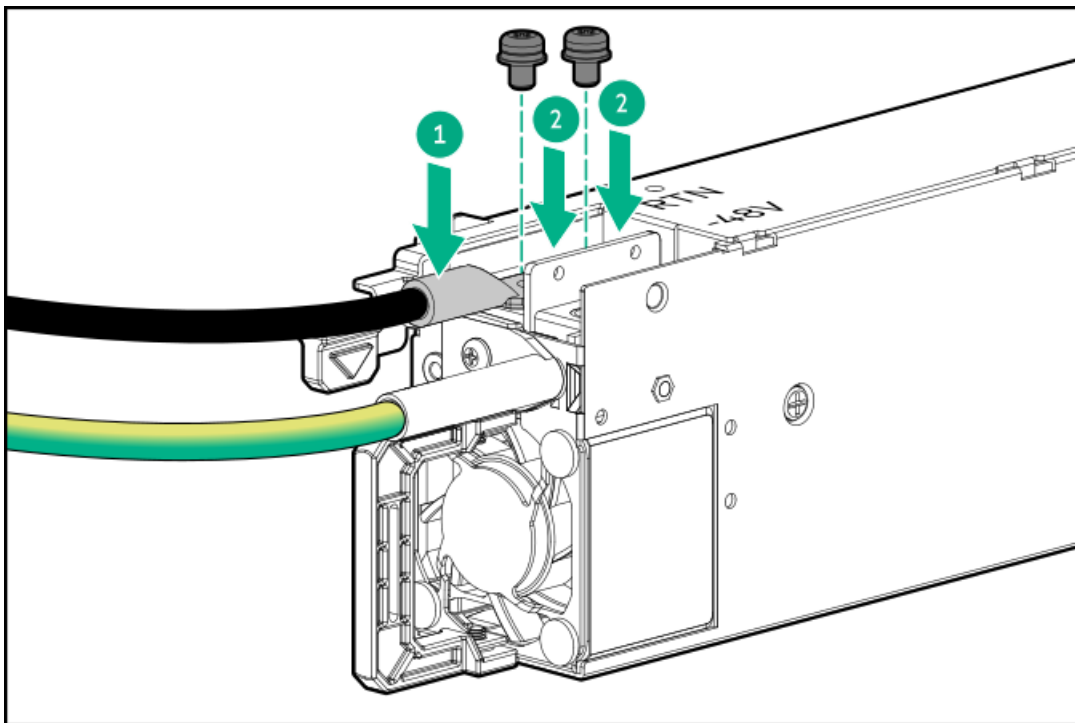

5. Install the line wire (red):

- a. Insert the line wire into the -48V slot on the DC power supply.
- b. Tighten the screw to 0.98 N-m (8.68 lbf-in).



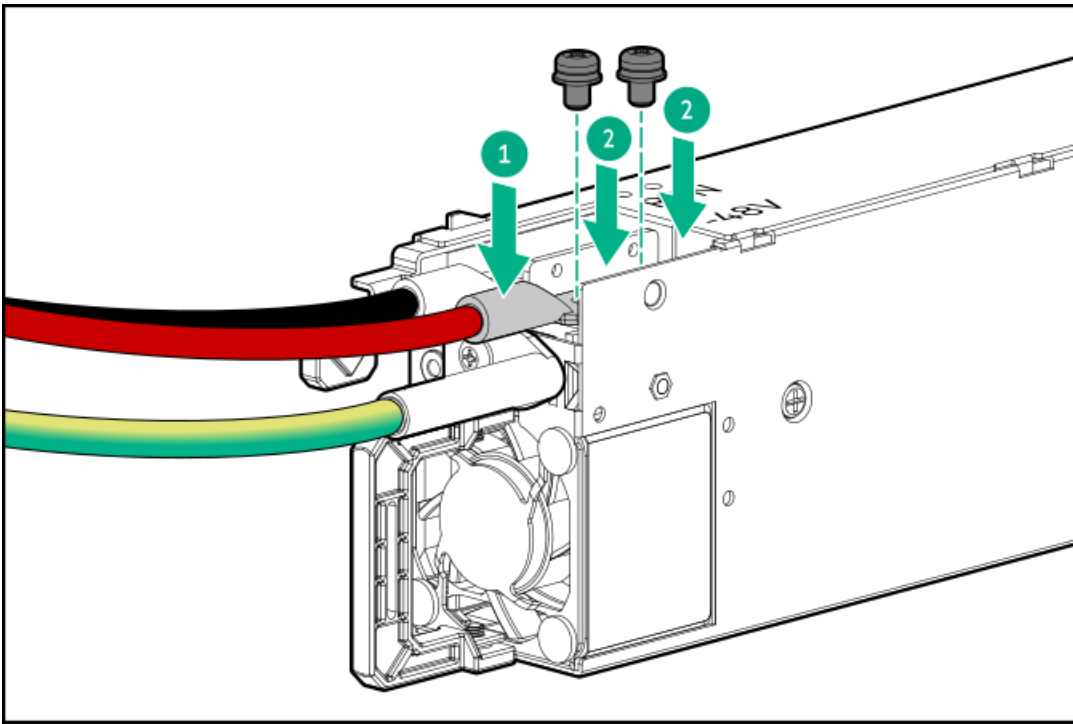

6. Install the protective cover on the DC power supply.

Make sure that the protective cover is locked.

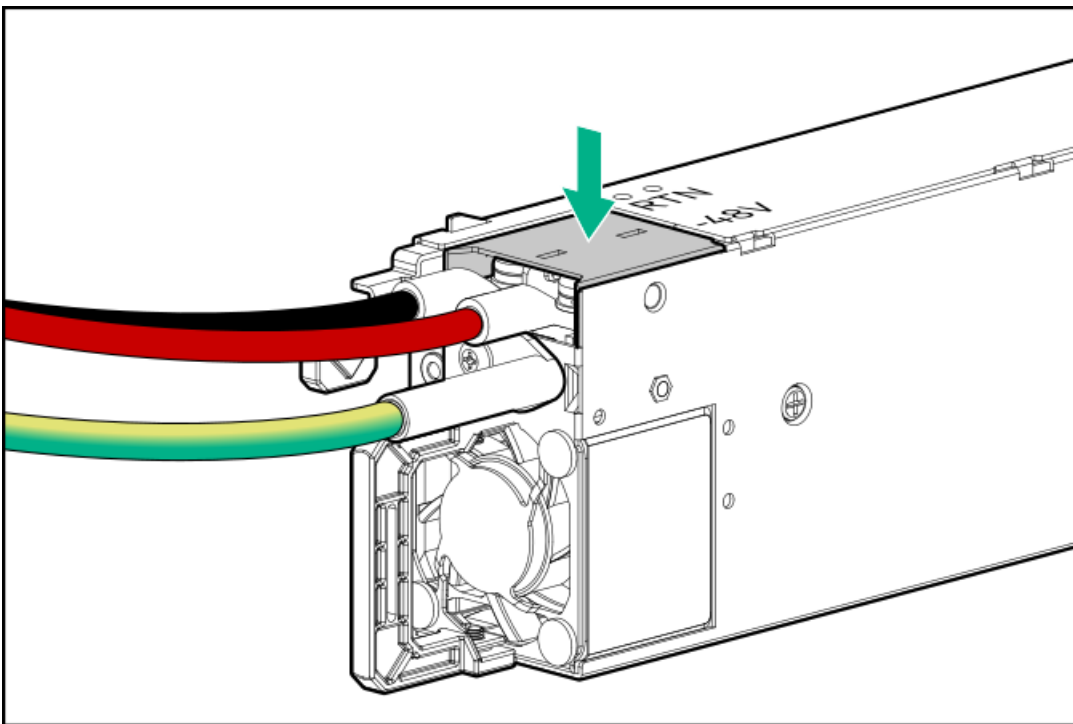

7. Secure the ground, positive return, and negative input wires in the strain relief strap.

CAUTION: Avoid tight bend radii to prevent damaging the internal wires of a power cord or a server cable. Never bend power cords and server cables tight enough to cause a crease in the sheathing.

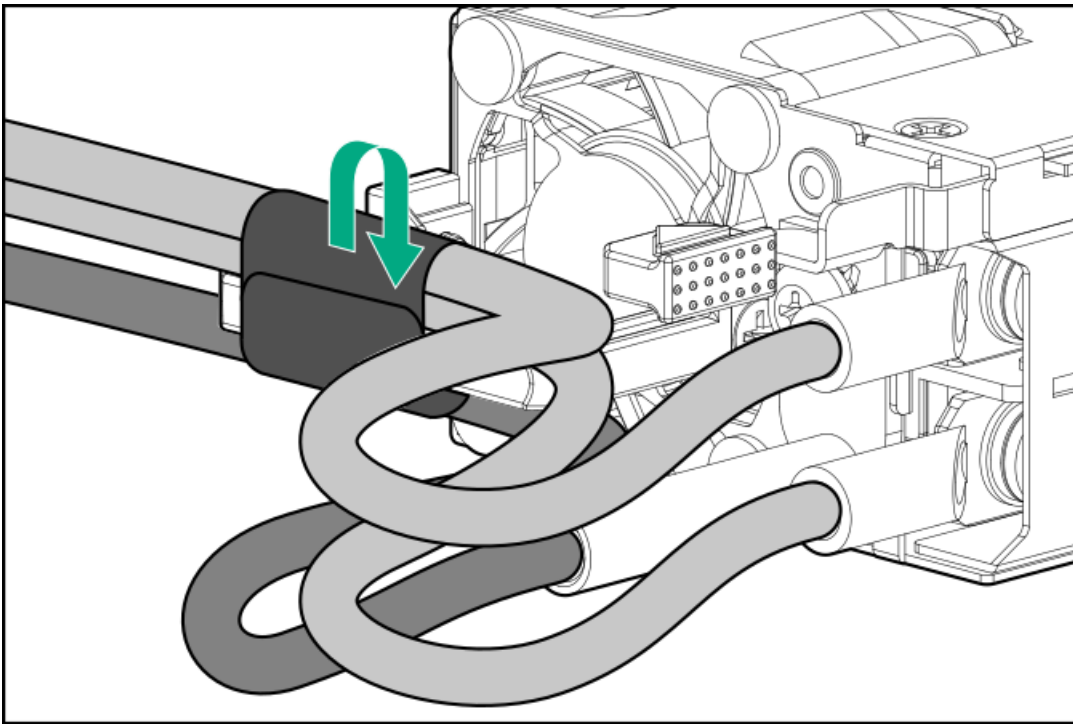

8. If you are installing a power supply in the power supply bay 2, remove the power supply blank.

Retain the blank for future use.

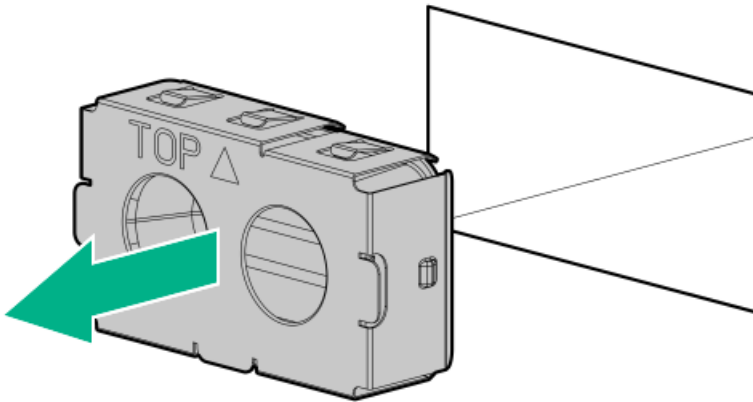

9. Immediately slide the power supply into the bay until it clicks into place.

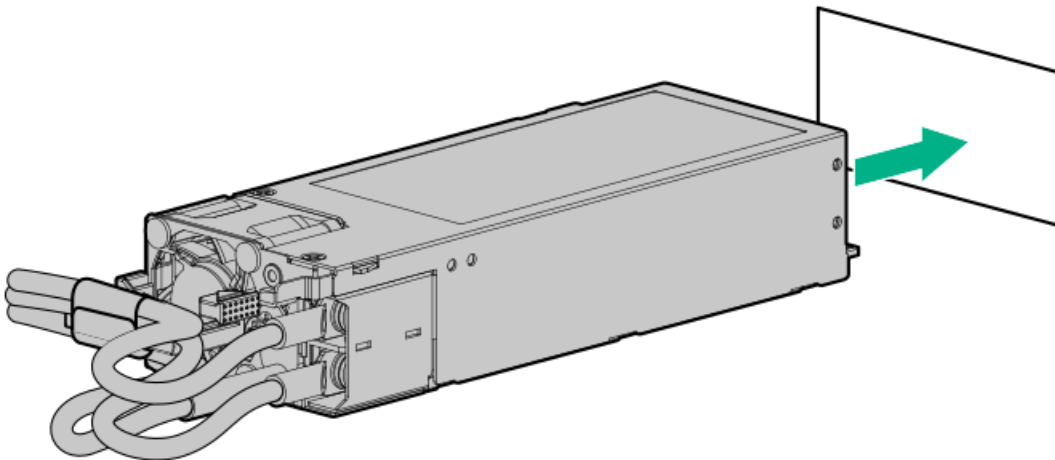

10. Make sure the -48 V DC power source is off or the PDU breaker is in the off position, and then connect the power cord to the -48 V DC power source or PDU.
11. Turn on the -48 V power source or switch the PDU breaker to the on position to supply -48 V to the power supply.
12. Connect a DC power cable to a DC power source.
13. Make sure that the power supply LED is green.

Results

The installation is complete.

Connecting a DC power cable to a DC power source

Prerequisites

Before you perform this procedure, make sure that you have the following items available:

- Electrical wire cutter
- Hand crimp tool

About this task



WARNING:

To reduce the risk of electric shock or energy hazards:

- This equipment must be installed by trained service personnel and in accordance with local and regional electric codes and regulations
- Connect the equipment to a reliably grounded secondary circuit source. A secondary circuit has no direct connection to a primary circuit and derives its power from a transformer, converter, or equivalent isolation device.
- The overcurrent protection for the DC source must not exceed 45 A.



WARNING:

When installing a DC power supply, the ground wire must be connected before the positive or negative leads.



WARNING:

Remove power from the power supply before performing any installation steps or maintenance on the power supply.



CAUTION:

The server equipment connects the earthed conductor of the DC supply circuit to the earthing conductor at the equipment. For more information, see the documentation that ships with the power supply.

⚠ CAUTION:

If a DC connection exists between the earthed conductor of the DC supply circuit and the earthing conductor at the server equipment, the following conditions must be met:

- This equipment must be connected directly to the DC supply system earthing electrode conductor or to a bonding jumper from an earthing terminal bar or bus to which the DC supply system earthing electrode conductor is connected.
 - Locate the equipment in the same immediate area (such as adjacent cabinets) as any other equipment that has a connection between the earthed conductor of the same DC supply circuit and the earthing conductor, and also the point of earthing of the DC system. The DC system must be earthed elsewhere.
 - The DC supply source is to be located within the same premises as the equipment.
 - Switching or disconnecting devices should not be in the earthed circuit conductor between the DC source and the point of connection of the earthing electrode conductor.
-

Procedure

1. Cut the DC power cord ends no shorter than 150.00 cm (59.06 in).

i IMPORTANT:

The ring terminals must be UL approved and accommodate 6 AWG wires.

i IMPORTANT:

The minimum nominal thread diameter of a pillar or stud type terminal must be 3.50 mm (0.138 in). The diameter of a screw type terminal must be 5.00 mm (0.197 in).

2. If the power source requires ring tongues, use a crimping tool to install the ring tongues on the power cord wires and ground wire.
3. Stack each same-colored pair of wires and then attach them to the same power source.

For more information, see the documentation that ships with the power supply.

Drive cage options

The server supports the following drive cage options:

- 4 LFF drive cage
- 8 SFF drive cage

This server supports mixed LFF + SFF hot-plug drive configurations.

Subtopics

[Installing the 4 LFF drive cage](#)

[Installing the 8 SFF drive cage](#)

Installing the 4 LFF drive cage

Prerequisites

Before you perform this procedure, make sure that you have a T-15 Torx screwdriver available.

About this task



The server supports the 4 LFF drive cage option. This option:

- Can be installed in boxes 1-3.
- Can be installed together with the 8 SFF drive cage option .
- Supports SAS and SATA drives .

CAUTION: A discharge of static electricity from a finger or other conductor might damage system boards or other static-sensitive devices. To prevent damage, observe antistatic precautions.

CAUTION: To prevent improper cooling and thermal damage, do not operate the server unless all bays are populated with either a component or a blank.

Procedure

1. Remove the front bezel.
2. Power down the server.
3. Remove all power:
 - a. Disconnect each power cord from the power source.
 - b. Disconnect each power cord from the server.
4. Disconnect all peripheral cables from the server.
5. Do one of the following:
 - If the server is in tower mode, place the server on a flat, level surface with the access panel facing up.
 - If the server is in rack mode, remove the server from the rack.
6. Remove the access panel.
7. Remove the fan cage.
8. Remove the drive box blank:
 - a. Remove the drive box blank screws.
 - b. Remove the drive box blank.

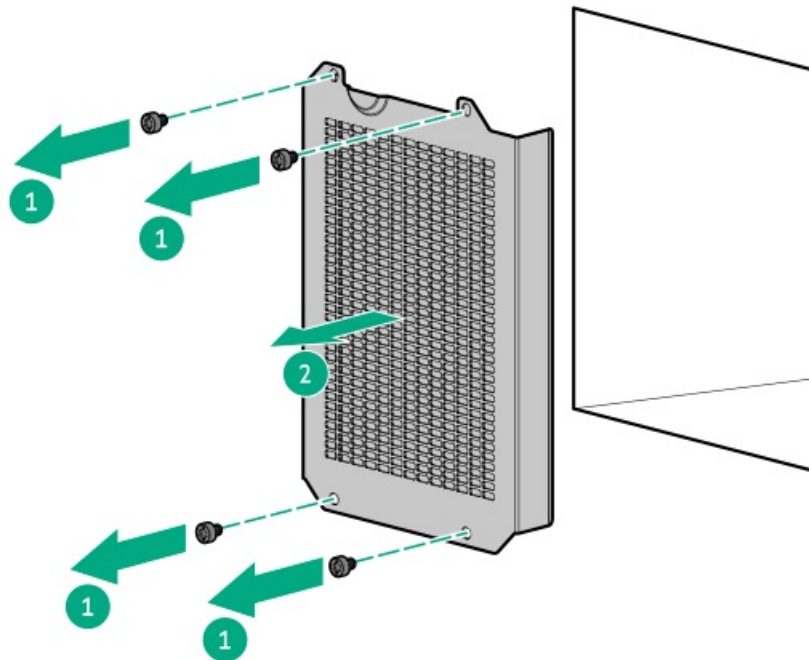

9. Install the 4 LFF drive cage:
 - a. Install the drive cage in the server.
 - b. Install the drive cage screws.

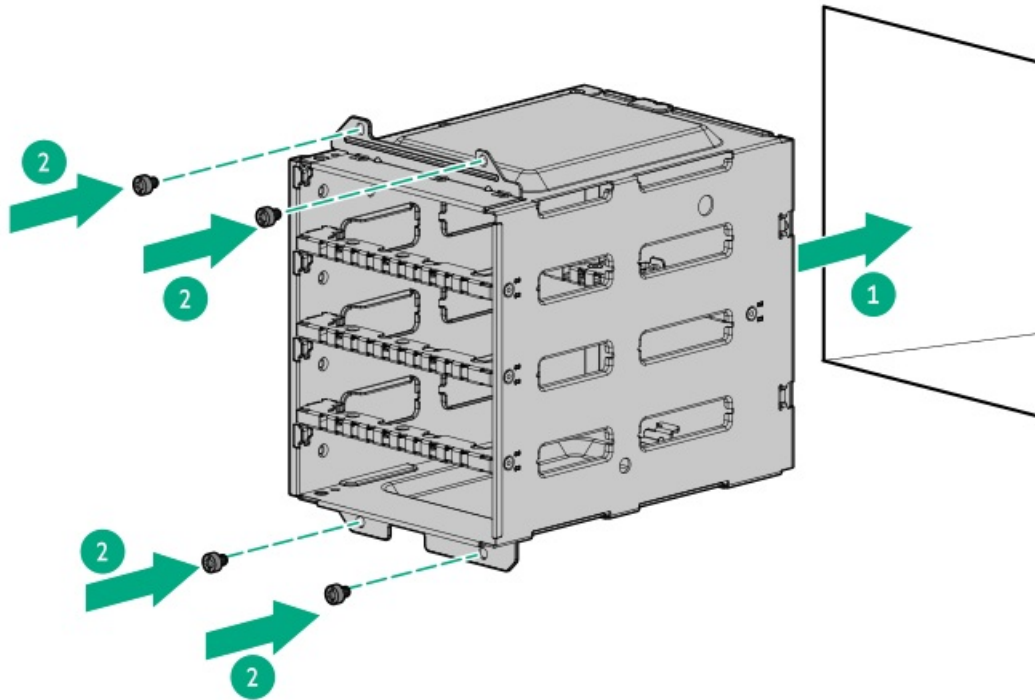

10. Connect the drive cables:
 - Storage controller cable
 - Drive power cable
11. Make sure that all the system cables that are routed through the front cable channel are properly secured in the metal cable tabs.
This is done to prevent system damage due to cables being inadvertently caught under the fan cage.
12. Install the fan cage.
13. Install the access panel.
14. Do one of the following:
 - Orient the server back in tower mode.
 - Install the server into the rack.
15. Connect all peripheral cables to the server.
16. Connect each power cord to the server.
17. Connect each power cord to the power source.
18. Power up the server.
19. Install the LFF hot-plug drives.
20. Install the front bezel.

Results

The installation is complete.

Installing the 8 SFF drive cage

Prerequisites

Before you perform this procedure, make sure that you have a T-15 Torx screwdriver available.

About this task

This server supports several front 8 SFF drive cage options with [different backplanes](#) This option:

- Can be installed in boxes 1-3.
- [Can be installed together with the 4 LFF drive cage option](#) .
- Supports SAS, SATA, and U.3 PCIe4 NVMe drives .

 **CAUTION:** A discharge of static electricity from a finger or other conductor might damage system boards or other static-sensitive devices. To prevent damage, observe [antistatic precautions](#).

 **CAUTION:** To prevent improper cooling and thermal damage, do not operate the server unless all bays are populated with either a component or a blank.

Procedure

1. [Remove the front bezel](#).
2. [Power down the server](#).
3. Remove all power:
 - a. Disconnect each power cord from the power source.
 - b. Disconnect each power cord from the server.
4. Disconnect all peripheral cables from the server.
5. Do one of the following:
 - If the server is in tower mode, [place the server on a flat, level surface with the access panel facing up](#).
 - If the server is in rack mode, [remove the server from the rack](#).
6. [Remove the access panel](#).
7. [Remove the fan cage](#).
8. Remove the drive box blank:
 - a. Remove the drive box blank screws.
 - b. Remove the drive box blank.

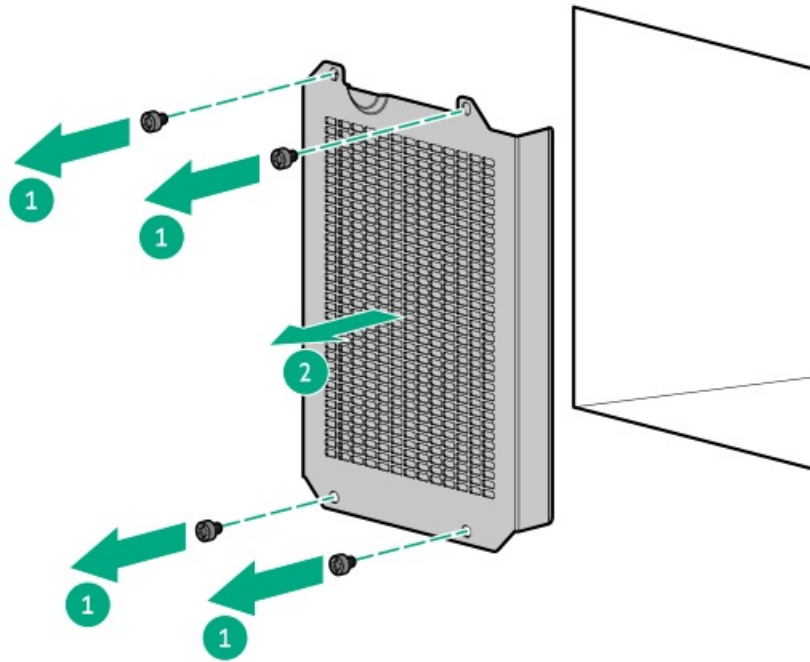

9. Install the 8 SFF drive cage:

- a. Install the drive cage in the server.
- b. Install the drive cage screws.

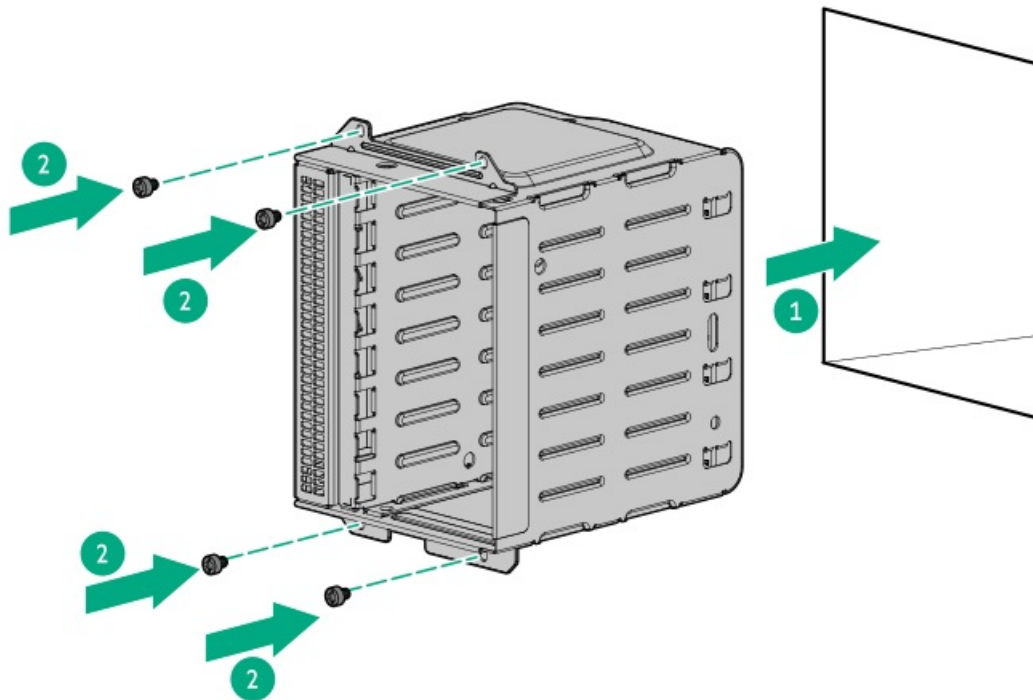

10. Connect the drive cables:

- [Storage controller cable](#)
- [Drive power cable](#)

11. Make sure that all the system cables that are routed through the front cable channel are properly secured in the metal cable tabs.

This is done to prevent system damage due to cables being inadvertently caught under the fan cage.

12. [Install the fan cage.](#)



13. Install the access panel.
14. Do one of the following:
 - Orient the server back in tower mode.
 - Install the server into the rack.
15. Connect all peripheral cables to the server.
16. Connect each power cord to the server.
17. Connect each power cord to the power source.
18. Power up the server.
19. Install the LFF hot-plug drives.
20. Install the front bezel.

Results

The installation is complete.

Media device options

The server supports the following media device options in the box 1 bays:

- Media bay 1/2—USB RDX docking station
 - Only one USB RDX docking station can be installed at one time.
- Optical drive bay—SATA optical drive

Subtopics

[USB RDX backup system option](#)

[Optical drive option](#)

USB RDX backup system option

Install an RDX backup system as an inexpensive and portable way of storing data backups. The ruggedized design of this backup system works especially well in harsh work environments. The backup system consists of two components:

- RDX docking station
- RDX cartridge

For more information on installing and configuring the RDX disk backup system, see the RDX product documentation:

<https://www.hpe.com/info/rdx>

Subtopics

[Installing a USB RDX docking station](#)

[Enable the increased cooling mode](#)

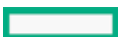

Installing a USB RDX docking station

Prerequisites

Before you perform this procedure, make sure the following:

- [The internal USB port is available.](#)
- [The tertiary riser is installed.](#)
- You have the following items available:
 - RDX supplementary option kit (P49694-B21)—This option kit includes:
 - RDX USB cable
 - RDX power Y-cable
 - Half-height media bay blank
 - Full-height media bay blank
 - RDX docking station option – The USB and/or power cables that ship with the drive option will not be used in this server.
 - T-15 Torx screwdriver

About this task

 **CAUTION:** A discharge of static electricity from a finger or other conductor might damage system boards or other static-sensitive devices. To prevent damage, observe [antistatic precautions](#).

 **CAUTION:** To prevent improper cooling and thermal damage, do not operate the server unless all bays are populated with either a component or a blank.

Procedure

1. [Remove the front bezel.](#)
2. [Power down the server.](#)
3. Remove all power:
 - a. Disconnect each power cord from the power source.
 - b. Disconnect each power cord from the server.
4. Disconnect all peripheral cables from the server.
5. Do one of the following:
 - If the server is in tower mode, [place the server on a flat, level surface with the access panel facing up](#).
 - If the server is in rack mode, [remove the server from the rack](#).
6. [Remove the access panel.](#)
7. [Remove the fan cage.](#)
8. Remove the drive box blank:
 - a. Remove the drive box blank screws.
 - b. Remove the drive box blank.

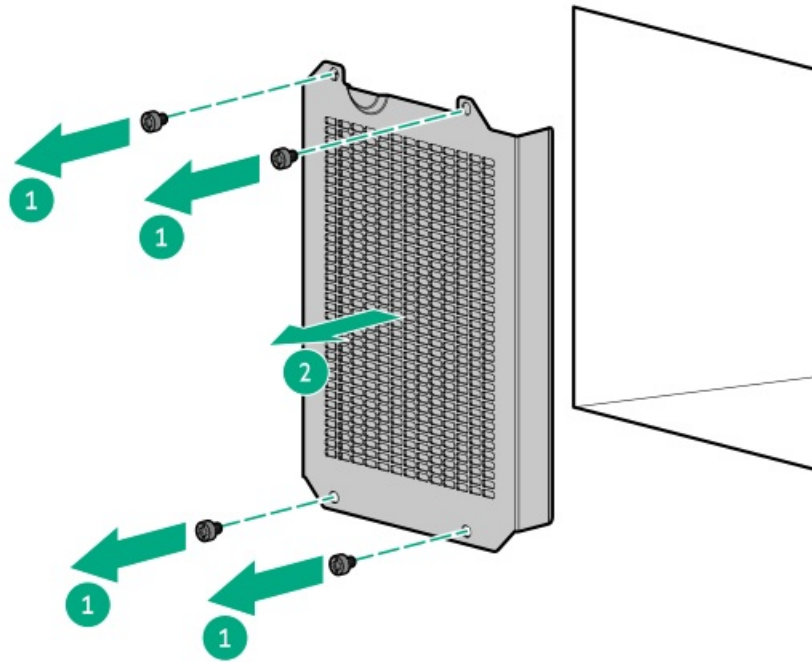

9. Remove the media bay filler panel:

- a. Remove the media bay filler panel screws.
- b. Remove the media bay filler panel.

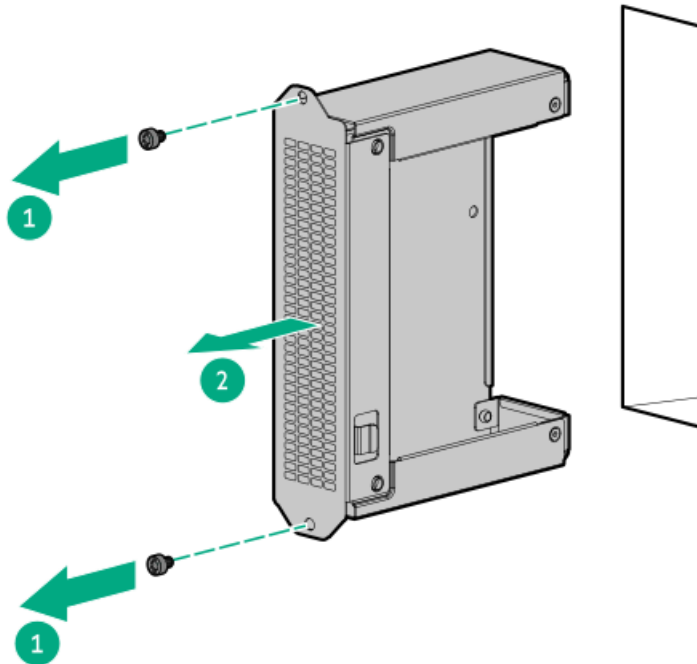

10. Install the RDX docking station screws.

These screws are included in the RDX docking station option kit. If the option kit does not include screws, use the [media device screws on the front panel](#).



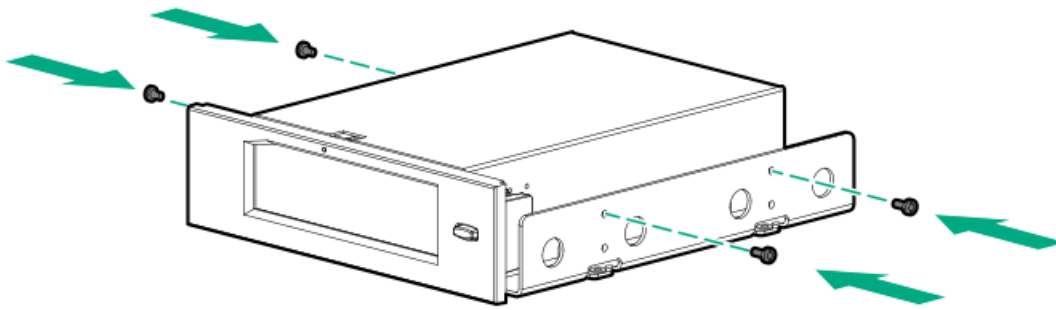

11. Slide the RDX docking station into the media bay until it clicks into place.
Leave enough space on the rear to connect the USB and power cables.

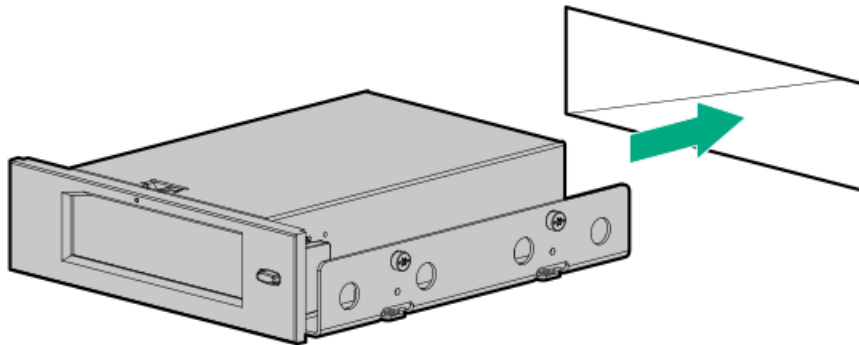

12. Connect the power and USB cables.
13. Make sure that all the system cables that are routed through the front cable channel are properly secured in the metal cable tabs.
This is done to prevent system damage due to cables being inadvertently caught under the fan cage.
14. Install the fan cage.
15. Install the access panel.
16. Do one of the following:
 - Orient the server back in tower mode.
 - Install the server into the rack.
17. Connect all peripheral cables to the server.
18. Connect each power cord to the server.
19. Connect each power cord to the power source.
20. Power up the server.
21. Enable the increased cooling function.



22. Perform the configuration procedure required by the RDX system.

For more information, see the RDX system documentation.

Results

The installation is complete.

Enable the increased cooling mode

About this task

Some components might generate more heat than others. To maintain proper cooling, increase the fan speed.

Procedure

1. To enable the increased cooling mode in the UEFI System Utilities:
 - a. From the System Utilities screen, select System Configuration > BIOS/Platform Configuration (RBSU) > Advanced Options > Fan and Thermal Options > Thermal Configuration.
 - b. Select **Increased Cooling**.
 - c. Save your setting.
 - d. Reboot the server. A reboot is required after the setting is saved.
2. To enable the increased cooling mode in the iLO web interface:
 - a. From the iLO web interface, select Power & Thermal > Fans.
 - b. Click  next to the Summary category.

The Fan Settings page opens.
 - c. Select **Increased Cooling**.
 - d. Click **OK**.

Optical drive option

Install a slim-type SATA optical drive to read/write data on optical discs.

Subtopics

[Installing an optical drive](#)

Installing an optical drive

Prerequisites

Before you perform this procedure, make sure that you have the following items available:

- Optical drive SATA-power cable that ships with the optical drive option
- T-15 Torx screwdriver
- Phillips No. 1 screwdriver

- Spudger or any small prying tool

About this task

Install an optical drive in the optical drive bay.

CAUTION: A discharge of static electricity from a finger or other conductor might damage system boards or other static-sensitive devices. To prevent damage, observe antistatic precautions.

CAUTION: To prevent improper cooling and thermal damage, do not operate the server unless all bays are populated with either a component or a blank.

Procedure

1. Remove the front bezel.
2. Power down the server.
3. Remove all power:
 - a. Disconnect each power cord from the power source.
 - b. Disconnect each power cord from the server.
4. Disconnect all peripheral cables from the server.
5. Do one of the following:
 - If the server is in tower mode, place the server on a flat, level surface with the access panel facing up.
 - If the server is in rack mode, remove the server from the rack.
6. Remove the access panel.
7. Remove the fan cage.
8. Disconnect the front I/O cables from the system board.
9. Remove the front I/O cage:
 - a. Remove the front I/O cage screws.
 - b. Slide the front I/O cage out of the server.

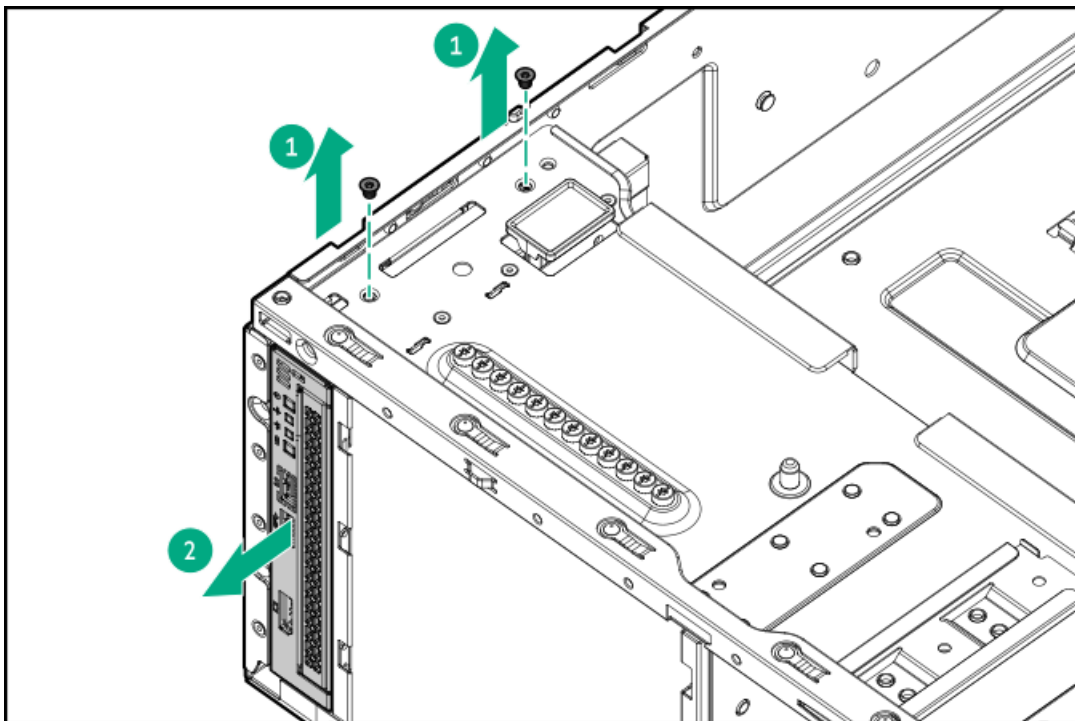

10. Remove the optical drive bay blank:
 - a. Use a plastic spudger to pry one side of the blank.
 - b. Remove the optical drive bay blank from the front I/O cage.

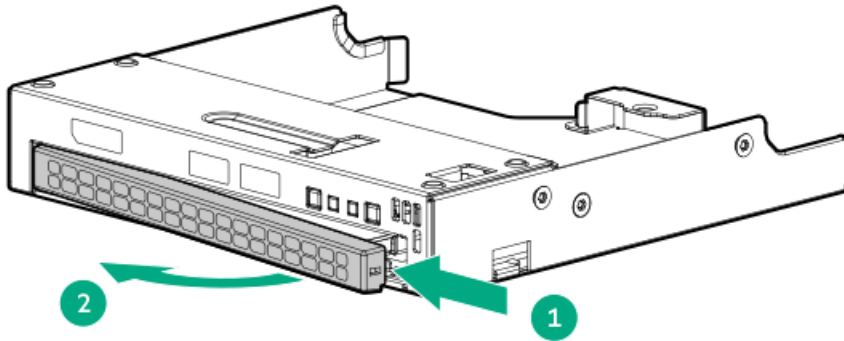

11. Install the optical drive bracket.

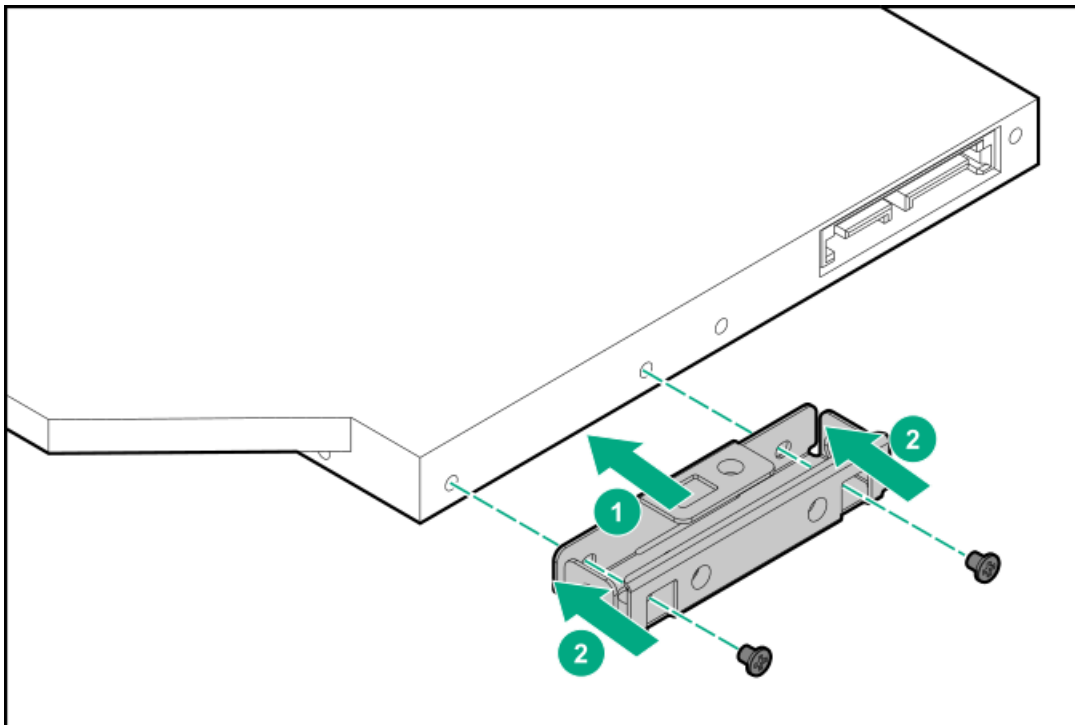

12. Install the optical drive in the front I/O cage:
 - a. Slide the optical drive into the front I/O cage.
 - b. Install the drive bracket screw.

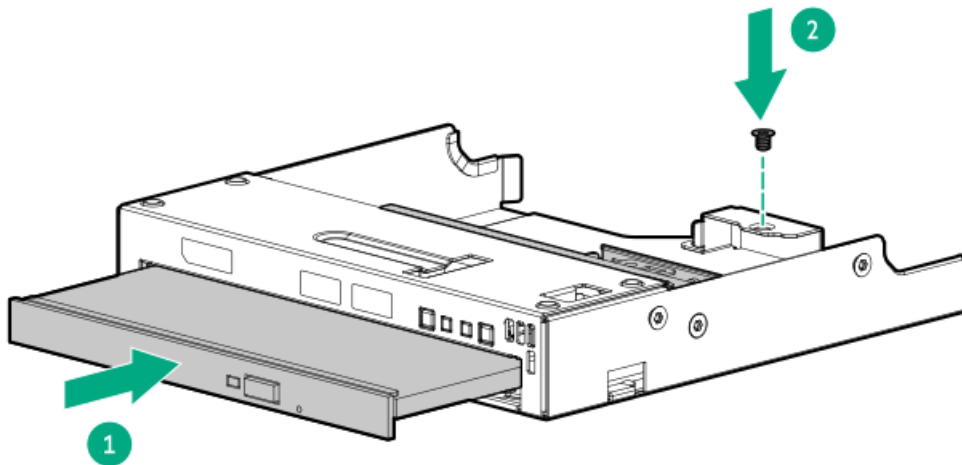

13. Install the front I/O cage:

- a. Slide the front I/O cage into the server until it clicks into place.
- b. Install the front I/O cage screws.

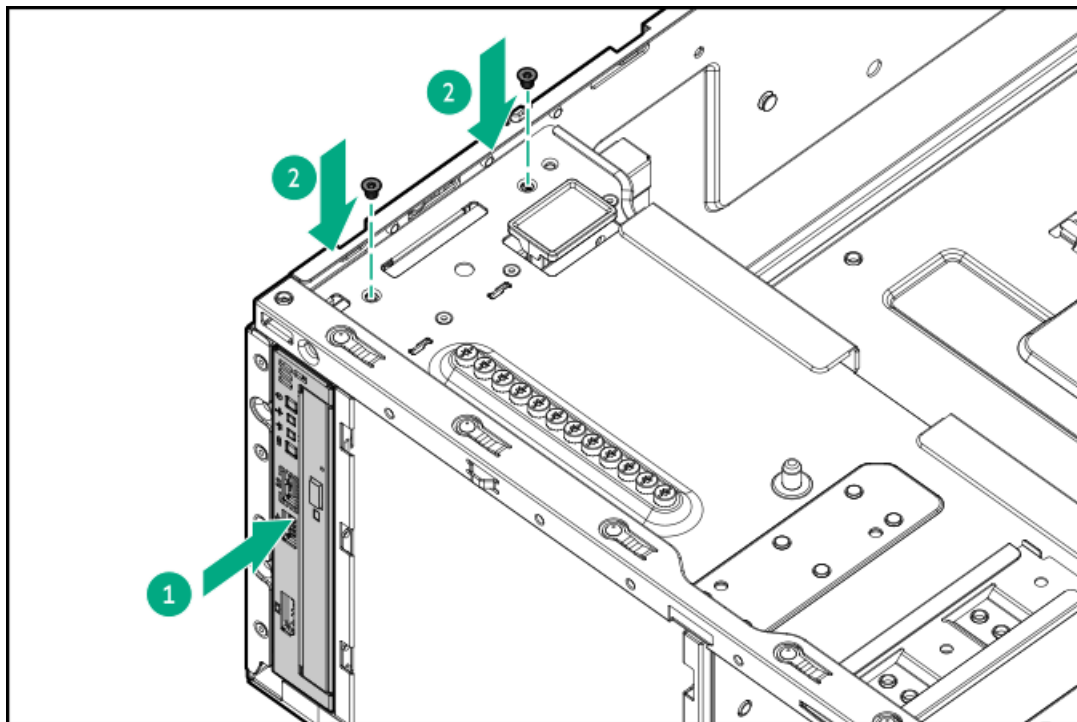

14. Connect the SATA-power Y-cable to the optical drive.

15. Connect the cables to the system board:

- [SATA-power Y-cable](#)
- [Front I/O cables](#)

16. Make sure that all the system cables that are routed through the front cable channel are properly secured in the metal cable tabs.

This is done to prevent system damage due to cables being inadvertently caught under the fan cage.



17. [Install the fan cage.](#)
18. [Install the access panel.](#)
19. Do one of the following:
 - [Orient the server back in tower mode.](#)
 - [Install the server into the rack.](#)
20. Connect all peripheral cables to the server.
21. Connect each power cord to the server.
22. Connect each power cord to the power source.
23. [Power up the server.](#)

Results

The installation is complete.

Transceiver option

Transceivers serve as the connection between the adapter and the network cable for maintaining high-speed performance.

Subtopics

[Transceiver warnings and cautions](#)

[Installing a transceiver](#)

Transceiver warnings and cautions



WARNING:

Fiber-optic transceivers and fiber-optic cables connected to transceivers emit laser light that can damage your eyes. To avoid eye injuries, avoid direct eye exposure to the beam from the fiber-optic transceiver or into the ends of fiber-optic cables when they are powered-up.



CAUTION:

The presence of dust in transceiver ports can cause poor cable connectivity. To prevent dust from entering, install a dust plug in an unused transceiver port.



CAUTION:

Supported transceivers can be hot-swapped—removed and installed while the server is powered-on. However, to prevent potential damage to the transceiver or the fiber-optic cable, disconnect the cable from the transceiver before hot-swapping it.



CAUTION:

Do not remove and install transceivers more often than is necessary. Doing so can shorten the useful life of the transceiver.



IMPORTANT:

When you replace a transceiver with another of a different type, the server might retain selected port-specific configuration settings that were configured for the replaced transceiver. Be sure to validate or reconfigure port settings as required.

Installing a transceiver

Prerequisites

Before installing a transceiver option, review the following:

- [Transceiver warnings and cautions](#)
- Transceiver documentation for specific operational and cabling requirements

Procedure

1. Hold the transceiver by its sides and gently insert it into the network adapter port until it clicks into place.

Transceivers are keyed so that they can only be inserted in the correct orientation. If the transceiver does not fit easily into the port, you might have positioned it incorrectly. Reverse the orientation of the transceiver and insert it again.

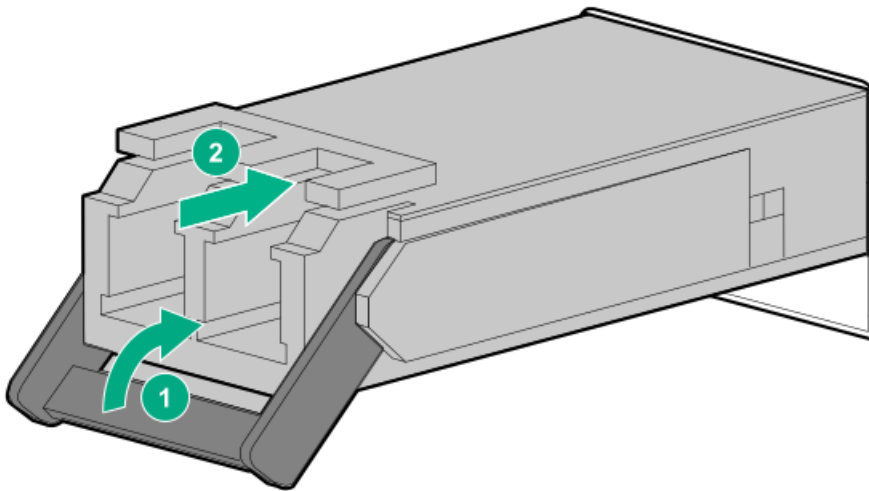

2. Remove the dust plug or protective cover from the transceiver.
3. Connect a compatible LAN segment cable to the transceiver.
4. Make sure that the NIC link LED on the port is solid green.

For more information on the port LED behavior, see the documentation that ships with the transceiver.

5. If needed, see the transceiver documentation for the model-specific fastening mechanism applicable to the transceiver.

Results

The installation is complete.

Fan options





- Internal fans: Fan bays 1–8 in the fan cage.
- External fans: Fan bays 9–10 on the rear panel.

For more information on fan requirements for specific hardware configurations, see [Fan population](#).

Subtopics

[Fan population](#)

[Fan redundancy support](#)

[Fan mode behavior](#)

[Installing an internal fan](#)

[Installing the external fan](#)

Fan population

- In a single-processor system, nonredundant configuration, fans 2–4 are preinstalled in the fan cage and a fan blank is preinstalled in bay 1.
- In a dual-processor system, nonredundant configuration requires a fan in bay 1.
- To enable redundant fan mode in single- and dual-processor systems, install fans in bay 1, 5–8.
- In the E3.S drive configuration, the external fan 10 is default in the server.
- When installing high power accelerator options in the primary and secondary risers, external fans 9–10 covering the rear side of riser slots are highly recommended.
- To maintain optimum system cooling, observe the following fan requirements for specific hardware components:

Hardware component	Bay 1	Bays 2–4	Bays 5–8	Bay 9	Bay 10	Fan redundancy
HPE NS204i-u Boot Device	Fan	Fan	—	—	—	Not supported
Tertiary riser	Fan	Fan	—	—	—	Not supported
Processor with a TDP of 300 W or higher	Fan	Fan	Fan	—	—	Supported
High power accelerator ¹ on the primary riser	Fan	Fan	Fan	—	Fan ²	Supported
High power accelerator ¹ on the secondary riser	Fan	Fan	Fan	Fan ²	—	Supported
E3.S drives	Fan	Fan	Fan	—	Fan	Supported

¹ For limited operating inlet ambient temperature requirements when high power accelerators are installed, see the server QuickSpecs on the Hewlett Packard Enterprise website (<https://www.hpe.com/info/quickspecs>).

² For additional cooling support, Hewlett Packard Enterprise highly recommends installing an external fan.

Fan redundancy support

The number of fans installed in the server determines fan redundancy. When redundant fan mode is enabled, hot-plug fan operation is supported.

In this server, fan operation can either be:

- Hot-plug—A failed fan can be replaced without powering down the server.
- Non-hot-plug—To replace a failed fan, the user must either:
 - Keep the server powered on and complete the fan replacement within 60 seconds of opening the access panel, or
 - Power down and disconnect all power from the server before removing the access panel for fan replacement.

Fan mode behavior

- In nonredundant fan mode, a fan failure or a missing fan causes:
 - The system Health LED to flash amber.
 - The operating system to gracefully shut down.
- In redundant fan mode:
 - A fan failure or a missing fan will switch the system to nonredundant fan mode.

This change is indicated by the Health LED flashing amber. The system continues to operate normally in this mode.
 - A second fan failure or a missing fan causes the operating system to gracefully shut down.

INSTALLING AN INTERNAL FAN

About this task

The server supports a redundant fan option (P47219-B21) for bay 1 and a second processor fan option (P47902-B21) for bays 5–8. The fan modules in both fan options are identical.

CAUTION: To prevent improper cooling and thermal damage, do not operate the server unless all bays are populated with either a component or a blank.

Procedure

1. Power down the server.
2. Remove all power:
 - a. Disconnect each power cord from the power source.
 - b. Disconnect each power cord from the server.
3. Disconnect all peripheral cables from the server.
4. If the server is in tower mode, place the server on a flat, level surface with the access panel facing up.
5. If the server is in rack mode, do one of the following:
 - Extend the server from the rack.
 - Remove the server from the rack.
6. Unlock the front bezel.
7. Remove the access panel.
8. If installing the internal fan 1, remove the fan blank.

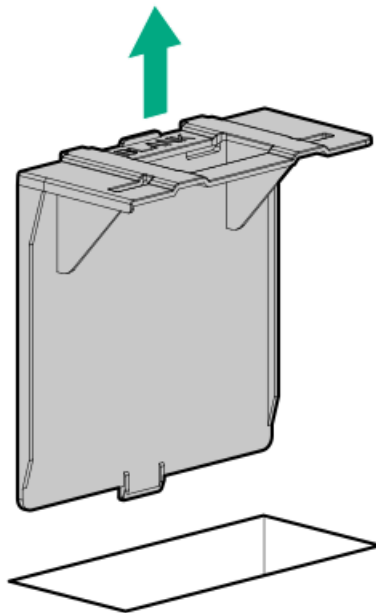

9. Install the internal fan:
 - a. Lower the fan into the bay.
 - b. Press down on the fan to make sure that it is seated firmly in the bay.

A click sound indicates that the fan is properly engaged.

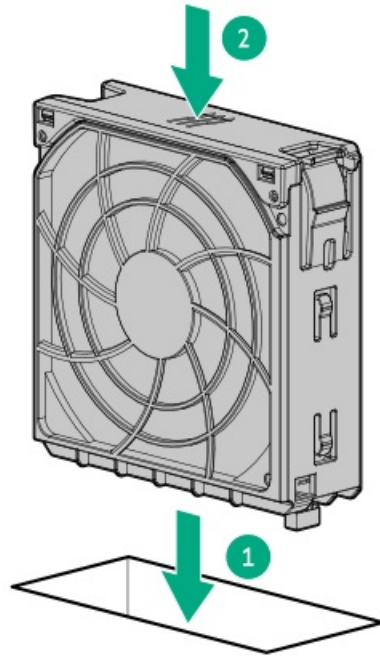

10. Install the access panel.
11. Lock the front bezel.
12. Do one of the following:
 - Orient the server back in tower mode.
 - Install the server into the rack.
13. Connect all peripheral cables to the server.
14. Connect each power cord to the server.
15. Connect each power cord to the power source.
16. Power up the server.

Results

The installation is complete.

Installing the external fan

Prerequisites

Before you perform this procedure, make sure that you have the following items available:

- T-10 Torx screwdriver
- T-15 Torx screwdriver

About this task



CAUTION: To prevent improper cooling and thermal damage, do not operate the server unless all bays are populated with either a component or a blank.

Procedure

1. Power down the server.
2. Remove all power:
 - a. Disconnect each power cord from the power source.
 - b. Disconnect each power cord from the server.
3. Disconnect all peripheral cables from the server.
4. If the server is in tower mode, place the server on a flat, level surface with the access panel facing up.
5. If the server is in rack mode, do one of the following:
 - Extend the server from the rack.
 - Remove the server from the rack.
6. Unlock the front bezel.
7. Remove the access panel.
8. If installing the external fan 10, remove the primary riser cage.
9. If installing the external fan 9, do one of the following:
 - Remove the secondary riser cage blank.
 - If installed, remove the secondary riser cage
10. Remove the external fan connector blank.

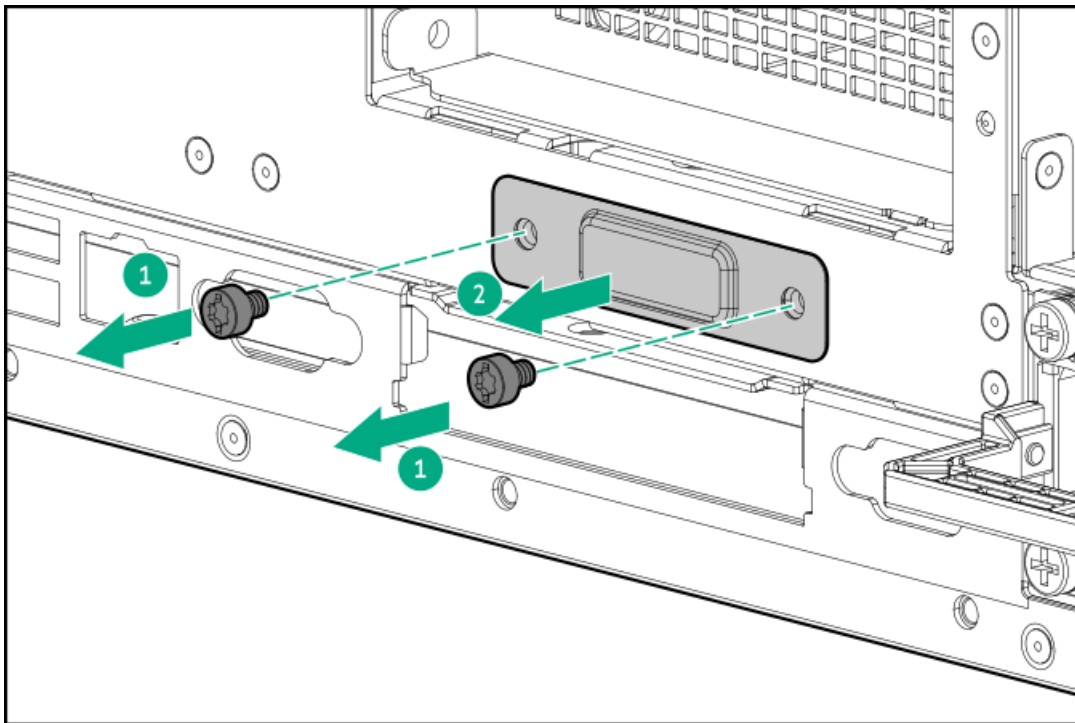

11. Install the external fan cable:
 - a. Install the cable in the cable connector slot.
 - b. Install the cable screw.

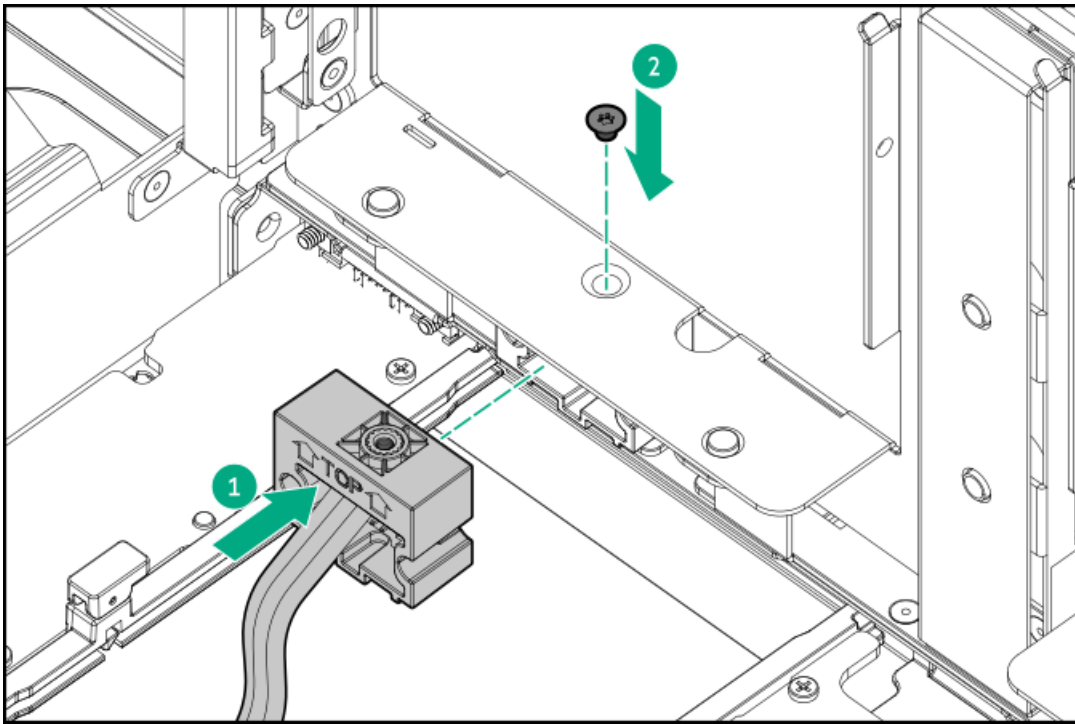

12. Install the external fan:

- a. Install the external fan into the bay.
- b. Tighten the captive screws.

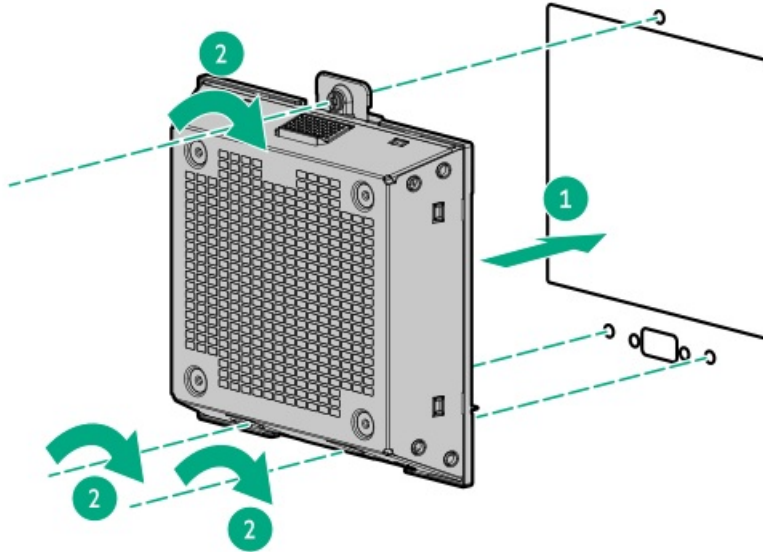

13. If removed, install the riser cage.

14. Install the access panel.

15. Lock the front bezel.

16. Do one of the following:

- Orient the server back in tower mode.
- Install the server into the rack.



17. Connect all peripheral cables to the server.
18. Connect each power cord to the server.
19. Connect each power cord to the power source.
20. Power up the server.

Results

The installation is complete.

Memory option

The server has 32 DIMM slots supporting HPE DDR5 SmartMemory (RDIMM).

The arrow points to the front of the server.

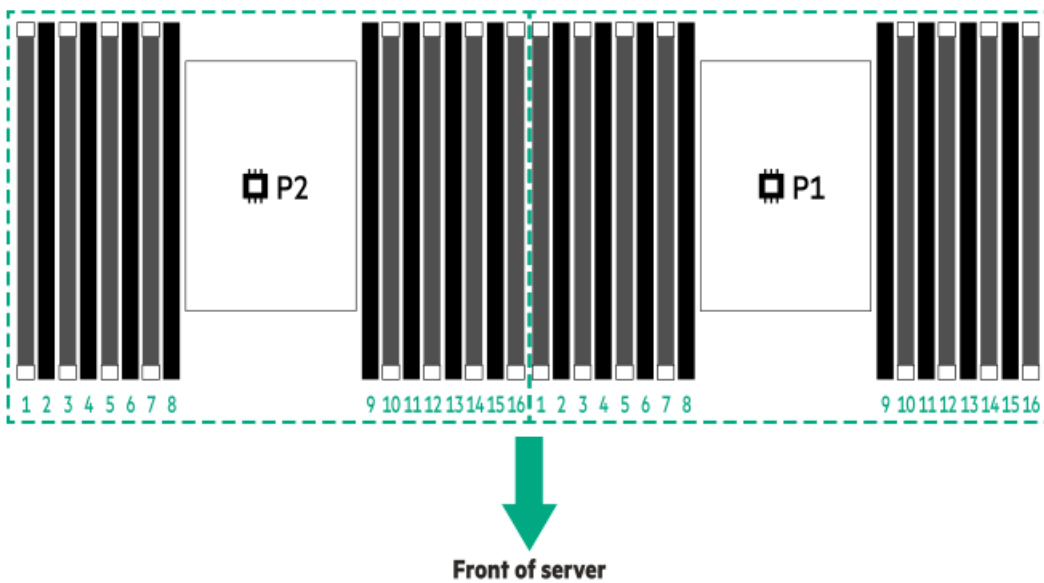

Subtopics

[HPE SmartMemory speed and population information](#)

[DIMM installation guidelines](#)

[Installing a DIMM](#)

HPE SmartMemory speed and population information

For information about memory speed and server-specific DIMM population rules for HPE servers using 4th and 5th Gen Intel Xeon Scalable Processors, see the relevant memory technical paper in:

<https://www.hpe.com/docs/server-memory>

DIMM installation guidelines

When handling a DIMM, observe the following:

- Observe antistatic precautions.
- Handle the DIMM only along the edges.
- Do not touch the components on the sides of the DIMM.
- Do not touch the connectors on the bottom of the DIMM.
- Never wrap your fingers around a DIMM.
- Never bend or flex the DIMM.

When installing a DIMM, observe the following:

- To align and seat the DIMM, use two fingers to hold the DIMM along the side edges.
- To seat the DIMM, use two fingers to apply gentle pressure along the top of the DIMM.

For more information, see the Hewlett Packard Enterprise website (<https://www.hpe.com/support/DIMM-20070214-CN>).

Installing a DIMM

Prerequisites

If installing the 256 GB DIMMs, review the Limited operating inlet ambient temperature requirements for DDR5 4800 256 GB DIMM.

About this task



CAUTION: A discharge of static electricity from a finger or other conductor might damage system boards or other static-sensitive devices. To prevent damage, observe antistatic precautions.

Procedure

1. Power down the server.
2. Remove all power:
 - a. Disconnect each power cord from the power source.
 - b. Disconnect each power cord from the server.
3. Disconnect all peripheral cables from the server.
4. Do one of the following:
 - If the server is in tower mode, place the server on a flat, level surface with the access panel facing up.
 - If the server is in rack mode, remove the server from the rack.
5. Unlock the front bezel.
6. Remove the access panel.
7. Remove the fan cage.
8. Install a DIMM in the standard heatsink configuration:
 - a. Open the DIMM slot latches.
 - b. Align the notch on the bottom edge of the DIMM with the keyed surface of the DIMM slot, and then fully press the DIMM into the slot until the latches snap back into place.

The DIMM slots are structured to ensure proper installation. If you try to insert a DIMM but it does not fit easily into the slot, you might have positioned it incorrectly. Reverse the orientation of the DIMM and insert it again.

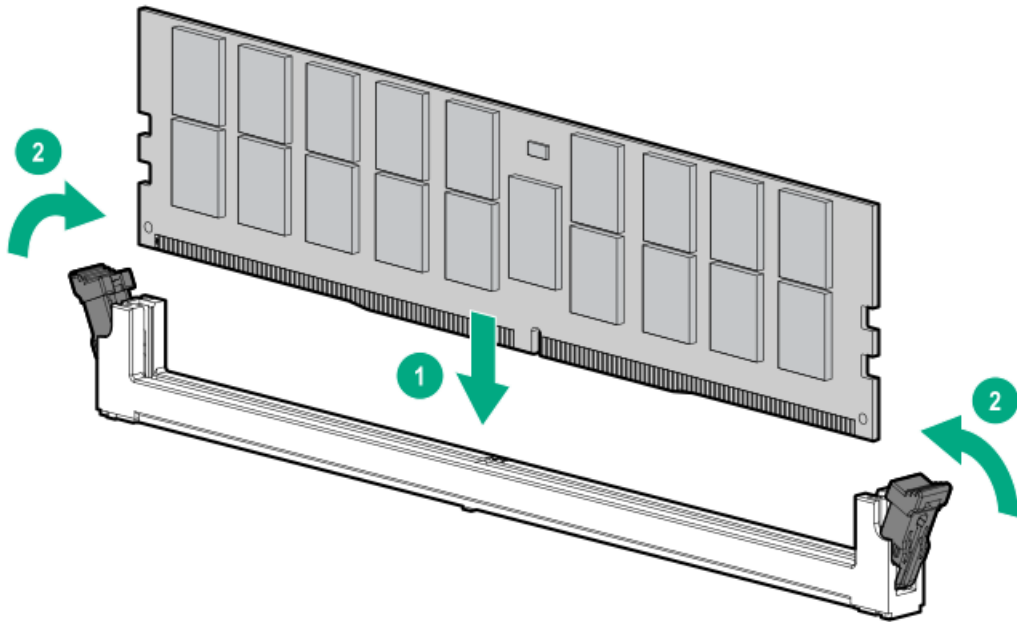

9. Install a DIMM in the performance heatsink configuration:

- a. Open the DIMM slot latches.
- b. Position the DIMM in a horizontal orientation and carefully slide the DIMM under the performance heatsink.

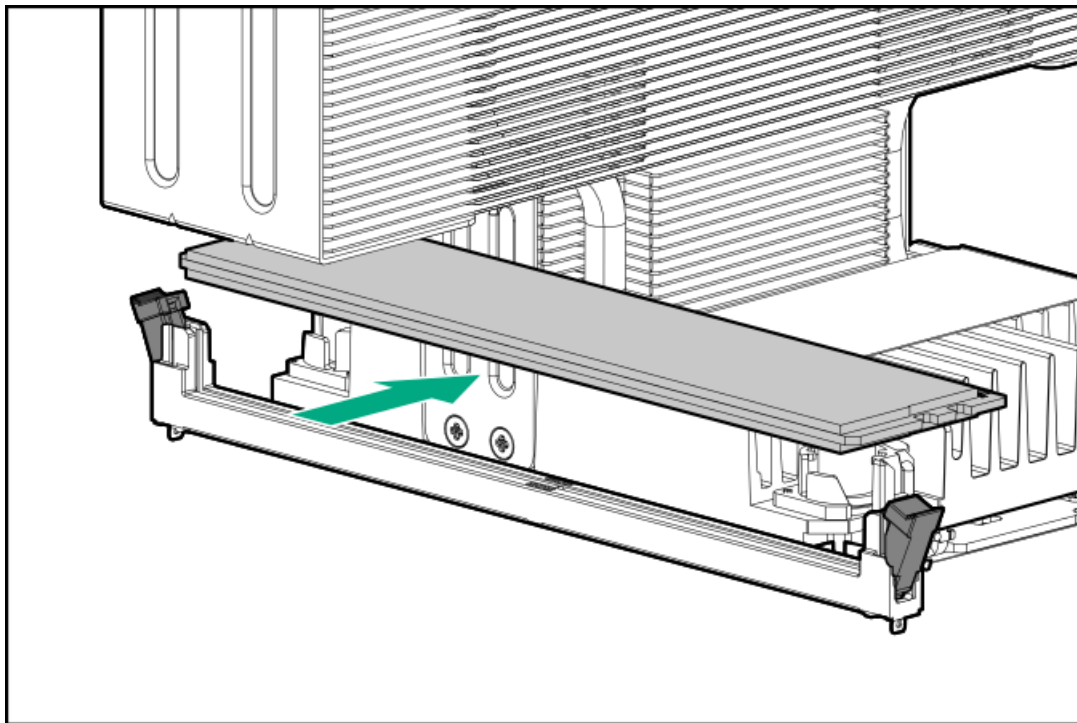

- c. Fully press the DIMM into the slot until the latches snap back into place.

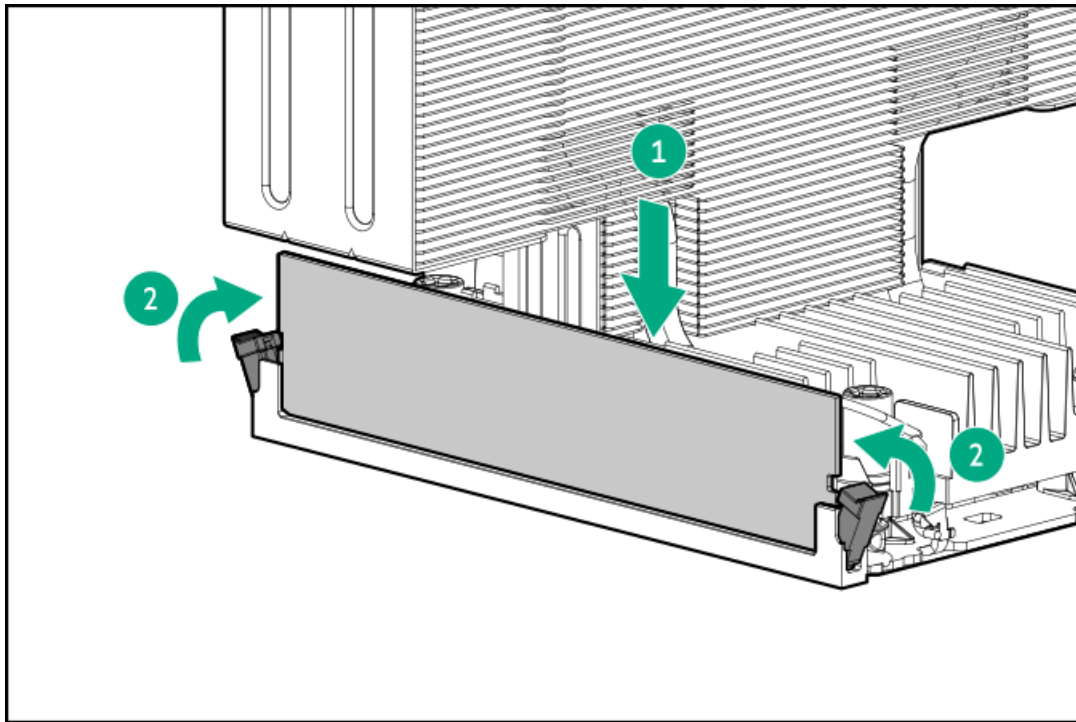

10. Install the fan cage.
11. Install the access panel.
12. Lock the front bezel.
13. Do one of the following:
 - Orient the server back in tower mode.
 - Install the server into the rack.
14. Connect all peripheral cables to the server.
15. Connect each power cord to the server.
16. Connect each power cord to the power source.
17. Power up the server.
18. To configure the memory settings:
 - a. From the boot screen, press **F9** to access the UEFI System Utilities.
 - b. From the System Utilities screen, select System Configuration > BIOS/Platform Configuration (RBSU) > Memory Options.

Results

The installation is complete.

Secondary riser cage and tertiary riser options

The primary riser cage is default in the server. The server supports two secondary riser cage options and one tertiary riser option.

These secondary riser options use the same riser cage but have different riser boards:

- PCIe5 4 x8 slots riser board
- PCIe5 2 x16 slots riser board

The tertiary riser uses the PCIe5 2 x8 slots riser board.

Subtopics

[Installing the secondary riser cage](#)

[Installing the tertiary riser](#)

Installing the secondary riser cage

Prerequisites

- If installing the secondary riser cage, [make sure that the server is in a dual-processor configuration](#).
- Before you perform this procedure, make sure that you have a T-10 Torx screwdriver available.

Procedure

1. [Power down the server](#).
2. Remove all power:
 - a. Disconnect each power cord from the power source.
 - b. Disconnect each power cord from the server.
3. Disconnect all peripheral cables from the server.
4. Do one of the following:
 - If the server is in tower mode, [place the server on a flat, level surface with the access panel facing up](#).
 - If the server is in rack mode, [remove the server from the rack](#).
5. Unlock the front bezel.
6. [Remove the access panel](#).
7. (Optional) [Install the expansion card](#).
8. [Remove the secondary riser cage blank](#).
9. Install the secondary riser cage:
 - a. Carefully press the riser down on its system board connector.
Make sure that:
 - The riser cage is aligned with the rear chassis.
 - The riser board is firmly seated on the system board.
 - b. Simultaneously push and rotate the half-turn spring latch to 180°.
 - c. Close the spring latch.

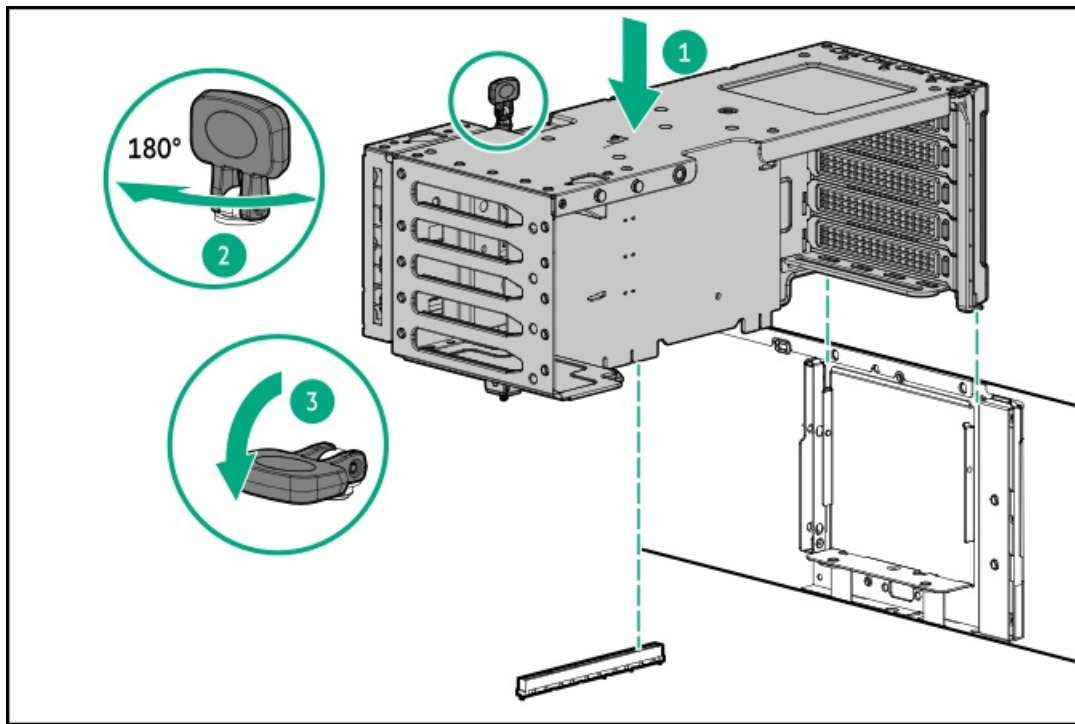

10. Install the access panel.
11. Lock the front bezel.
12. Do one of the following:
 - Orient the server back in tower mode.
 - Install the server into the rack.
13. Connect all peripheral cables to the server.
14. Connect each power cord to the server.
15. Connect each power cord to the power source.
16. Power up the server.

Results

The installation is complete.

Installing the tertiary riser

Prerequisites

Before you perform this procedure, make sure the following:

- If the tertiary riser is used for NIC card installation, the server is in a dual-processor configuration.
- Fan 1 is installed.

Procedure

1. Power down the server.
2. Remove all power:
 - a. Disconnect each power cord from the power source.



- b. Disconnect each power cord from the server.
3. Disconnect all peripheral cables from the server.
4. Do one of the following:
 - If the server is in tower mode, place the server on a flat, level surface with the access panel facing up.
 - If the server is in rack mode, remove the server from the rack.
5. Unlock the front bezel.
6. Remove the access panel.
7. Insert the stabilizer bracket in the chassis.

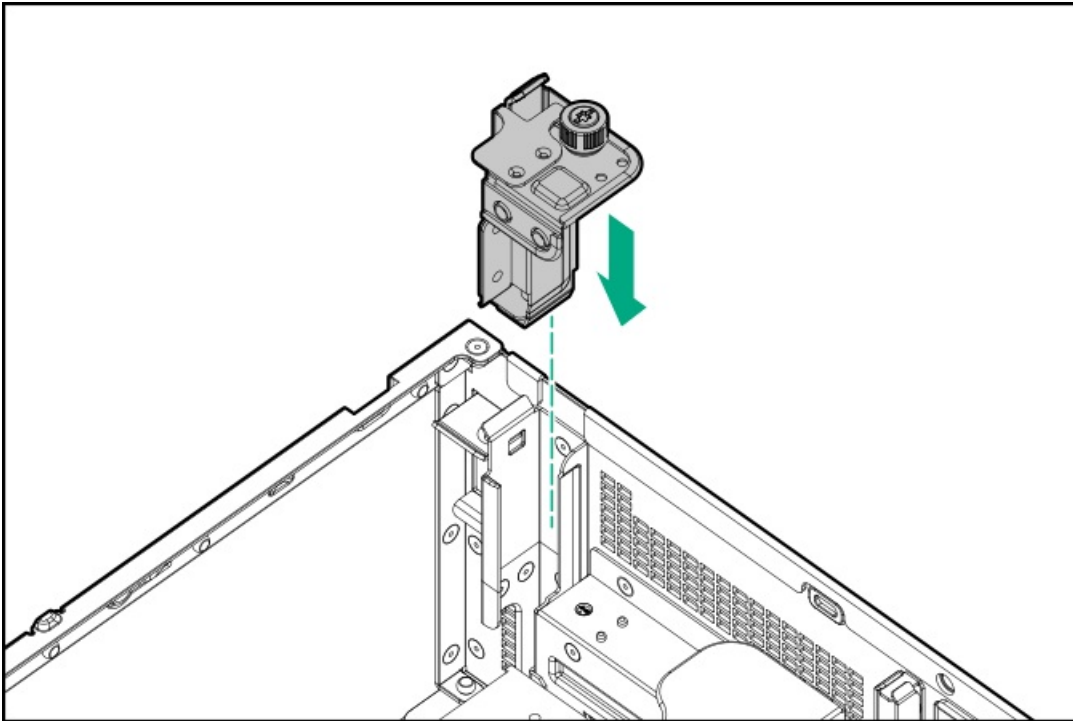

8. Remove the tertiary riser from the 2 x16 slots riser cage.

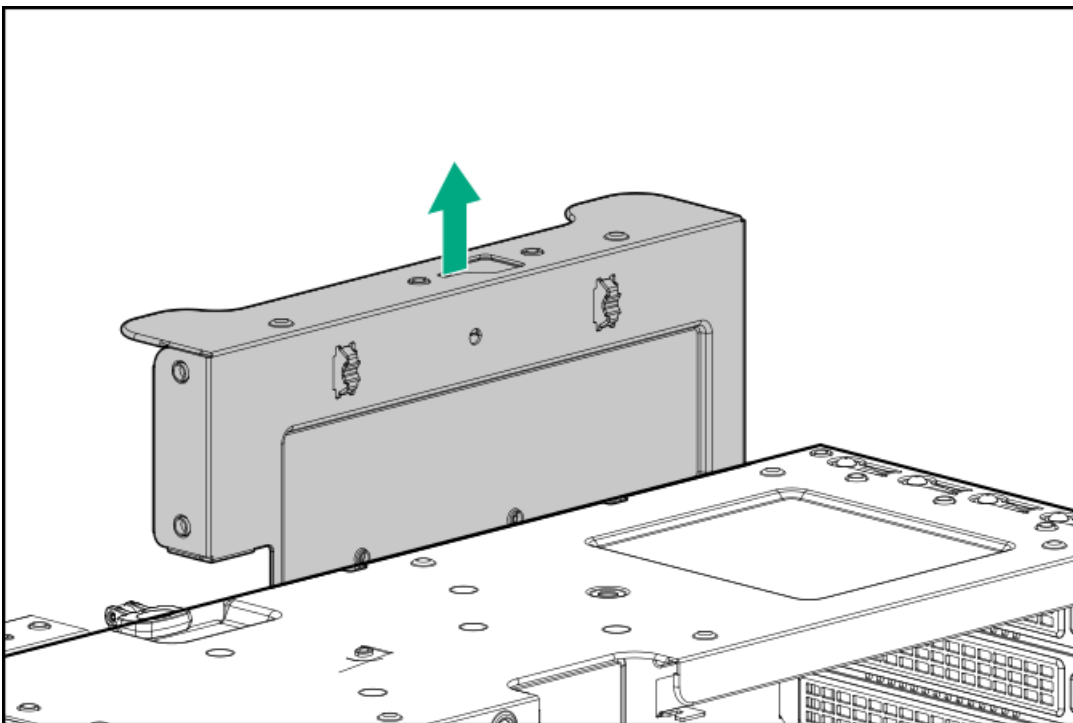

9. If the secondary riser cage is not preinstalled, [install the secondary riser cage](#).
10. Install the tertiary riser on the secondary riser cage.

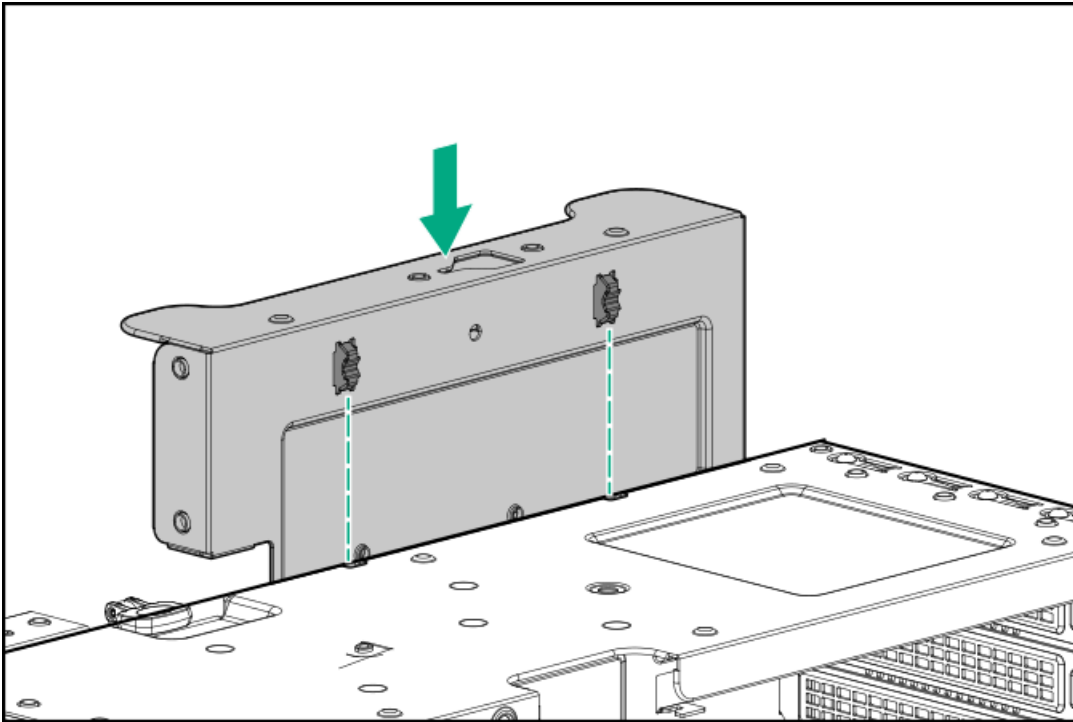

11. Cable the tertiary riser:
 - If installing the RDX docking station, [connect the RDX power cable](#).
 - If installing the expansion card, [connect the signal cables](#).
12. (Optional) [Install the expansion card](#).
13. [Install the access panel](#).
14. Lock the front bezel.
15. Do one of the following:
 - [Orient the server back in tower mode](#).
 - [Install the server into the rack](#).
16. Connect all peripheral cables to the server.
17. Connect each power cord to the server.
18. Connect each power cord to the power source.
19. [Power up the server](#).

Results

The installation is complete.

Storage controller options

The server supports the following storage controllers:

- Intel VROC for HPE Gen11 (Intel VROC)—Provides enterprise-level hybrid RAID support for direct attached SATA and NVMe SSDs.



- HPE MR type-o and type-p Gen11 controllers
- HPE SR type-p Gen11 controllers

For more information on drive array and storage controller configuration, see [Configuring storage controllers](#).

Subtopics

[Preparing the server for storage controller installation](#)

[Installing a type-p storage controller](#)

[Installing a type-o storage controller](#)

Preparing the server for storage controller installation

Prerequisites

Before beginning this procedure, download the Service Pack for ProLiant (SPP) from the Hewlett Packard Enterprise website (<https://www.hpe.com/servers/spp/download>).

Procedure

1. If the server was previously configured:
 - a. [Back up data on the system](#).
 - b. Close all applications.
 - c. Ensure that users are logged off and that all tasks are completed on the server.

 **CAUTION:** In systems that use external data storage, be sure that the server is the first unit to be powered down and the last to be powered back up. Taking this precaution ensures that the system does not erroneously mark the drives as failed when the server is powered up.

2. If the server firmware is not the latest revision, [update the firmware](#).
3. If the new controller is the new boot device, [install the controller drivers](#).

Installing a type-p storage controller

Prerequisites

- To enable the flash-backed write cache (FBWC) feature of a storage controller option, [install an energy pack](#).

For more information on the controller caching feature, see the controller QuickSpecs on the Hewlett Packard Enterprise website (<https://www.hpe.com/info/qs>).

- Before you perform this procedure, make sure that you have the following items available:
 - [Compatible controller cable](#)
 - T-10 Torx screwdriver

About this task

 **CAUTION:** A discharge of static electricity from a finger or other conductor might damage system boards or other static-sensitive devices. To prevent damage, observe [antistatic precautions](#).

Procedure

1. Power down the server.
2. Remove all power:
 - a. Disconnect each power cord from the power source.
 - b. Disconnect each power cord from the server.
3. Disconnect all peripheral cables from the server.
4. Do one of the following:
 - If the server is in tower mode, place the server on a flat, level surface with the access panel facing up.
 - If the server is in rack mode, remove the server from the rack.
5. Unlock the front bezel.
6. Remove the access panel.
7. Do one of the following:
 - Remove the primary riser cage.
 - Remove the secondary riser cage.
8. Remove the riser slot blank.

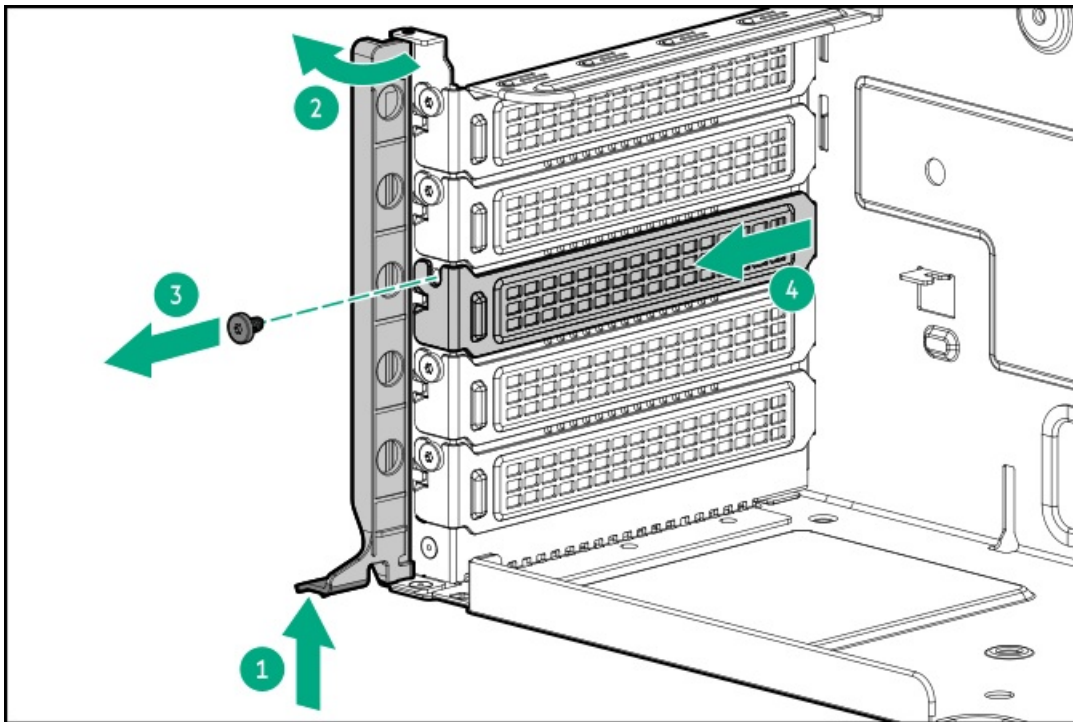

9. Install the type-p storage controller:
 - a. Install the type-p storage controller, and install the screw.
Make sure that the controller is seated firmly in the slot.
 - b. Simultaneously push and rotate to close the riser cage latch.

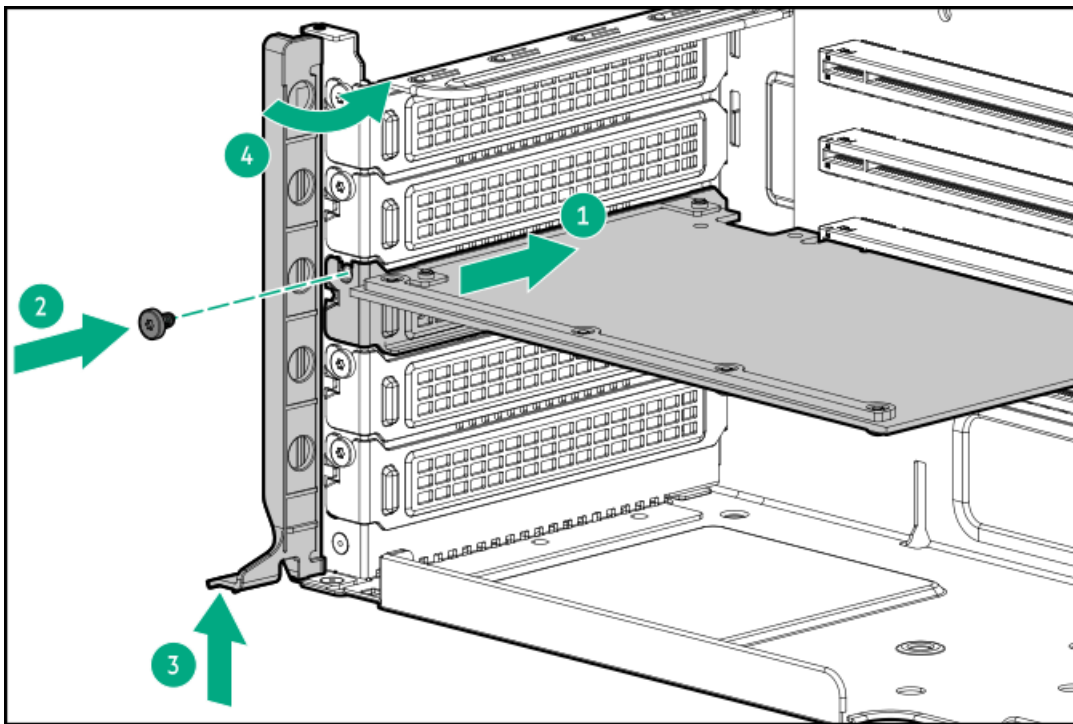

10. Install the primary riser cage.
11. Cable the type-p storage controller.
12. To enable the FBWC feature of the storage controller, install an energy pack.
13. Install the access panel.
14. Lock the front bezel.
15. Do one of the following:
 - Orient the server back in tower mode.
 - Install the server into the rack.
16. Connect all peripheral cables to the server.
17. Connect each power cord to the server.
18. Connect each power cord to the power source.
19. Power up the server.
20. Before using the controller for the first time, update the server and controller firmware if they are not the latest revision.
21. To configure the controller, see the relevant storage controller guide.

Results

The installation is complete.

Installing a type-o storage controller

Prerequisites

Before you perform this procedure, make sure that you have the following items available:

- Compatible controller cable

- T-10 Torx screwdriver

About this task

This server supports type-o storage controller installation in the OCP slot 14.

 **CAUTION:** A discharge of static electricity from a finger or other conductor might damage system boards or other static-sensitive devices. To prevent damage, observe antistatic precautions.

 **CAUTION:**
The port blank provides EMI shielding and helps maintain proper thermal status inside the server. Do not operate the server when a port blank is removed without the corresponding I/O port option installed.

Procedure

1. Power down the server.
2. Remove all power:
 - a. Disconnect each power cord from the power source.
 - b. Disconnect each power cord from the server.
3. Disconnect all peripheral cables from the server.
4. Do one of the following:
 - If the server is in tower mode, place the server on a flat, level surface with the access panel facing up.
 - If the server is in rack mode, remove the server from the rack.
5. Unlock the front bezel.
6. Remove the access panel.
7. Remove the primary riser cage.
8. Remove the OCP slot blank:
 - a. Remove the blank screw.
 - b. Use a plastic spudger to pry the top side of the blank from the chassis.
 - c. Remove the blank.

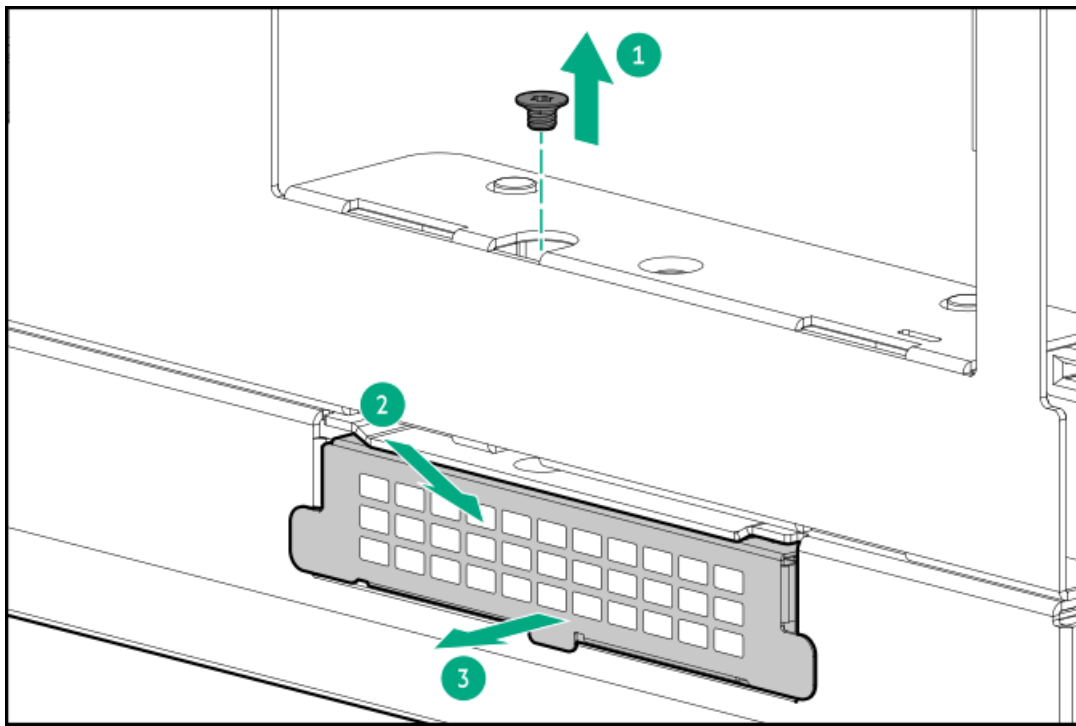

9. Install the type-o storage controller:

- a. Rotate the locking pin to the open (vertical) position.
- b. Slide the controller into the bay until it clicks into place.
Make sure that the controller is seated firmly in the slot.
- c. Rotate the locking pin to the close (horizontal) position.

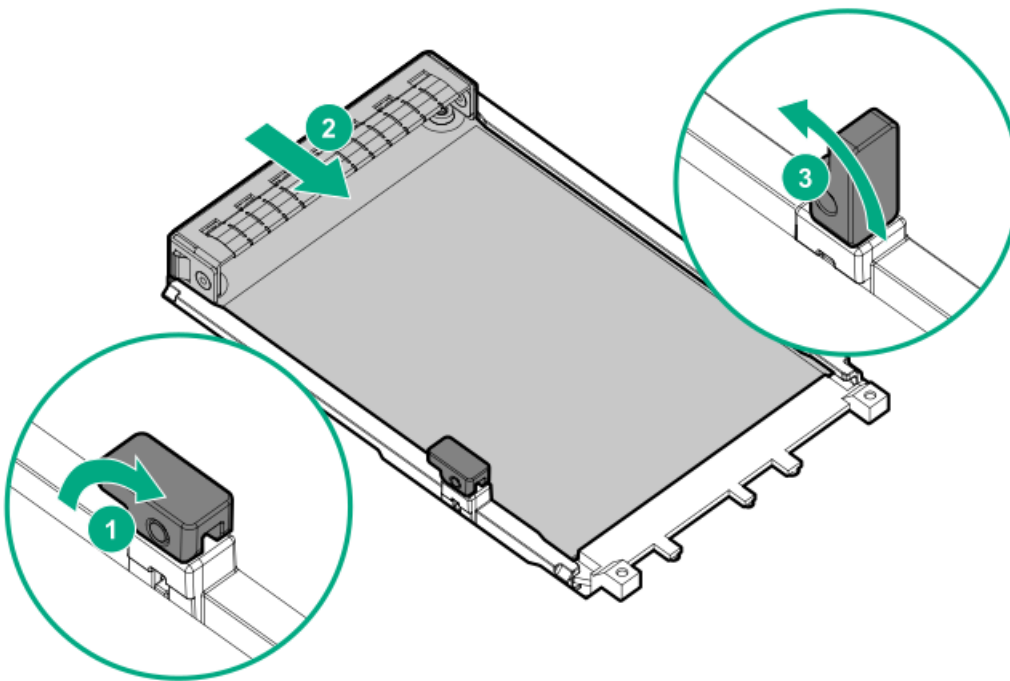

10. Cable the type-o storage controller.
11. Install the primary riser cage.
12. Install the access panel.
13. Lock the front bezel.



14. Do one of the following:
 - [Orient the server back in tower mode.](#)
 - [Install the server into the rack.](#)
15. Connect all peripheral cables to the server.
16. Connect each power cord to the server.
17. Connect each power cord to the power source.
18. [Power up the server.](#)
19. Before using the controller for the first time, [update the server and controller firmware if they are not the latest revision.](#)
20. To configure the controller, see the [relevant storage controller guide.](#)

Results

The installation is complete.

Energy pack options

If there is an unplanned server power outage, the flash-backed write cache (FBWC) feature of HPE storage controllers requires a centralized backup power source to back up the write cache data in a flash device. This server supports the following power options—collectively known as energy pack:

- [HPE Smart Storage Battery](#)
- [HPE Smart Storage Hybrid Capacitor](#)

One energy pack supports multiple devices. After it is installed, the status of the energy pack appears in HPE iLO. For more information, see the iLO user guide:

<https://www.hpe.com/support/ilo6>

Subtopics

[HPE Smart Storage Battery](#)

[HPE Smart Storage Hybrid Capacitor](#)

[Installing an energy pack](#)

HPE Smart Storage Battery

The HPE Smart Storage Battery supports both HPE SR and MR storage controllers.

A single 96 W battery can support up to 24 devices.

After the battery is installed, it might take up to two hours to charge. Controller features requiring backup power are not re-enabled until the battery is capable of supporting the backup power.

This server supports the 96 W HPE Smart Storage Battery with the 260 mm cable.

For more information, see HPE Smart Storage Batteries and Hybrid Capacitors QuickSpecs:

https://www.hpe.com/psnow/doc/a00028553enw.pdf?jumpid=in_pdp-psnow-qs

HPE Smart Storage Hybrid Capacitor

The HPE Smart Storage Hybrid Capacitor supports both HPE SR and MR storage controllers.

The capacitor pack can support up to three devices.

This server supports the HPE Smart Storage Hybrid Capacitor with the 260 mm cable.

Before installing the HPE Smart Storage Hybrid Capacitor, verify that the system BIOS meets the minimum firmware requirements to support the capacitor pack.



IMPORTANT:

If the system BIOS or controller firmware is older than the minimum recommended firmware versions, the capacitor pack will only support one device.

The capacitor pack is fully charged after the system boots.

For more information, see HPE Smart Storage Batteries and Hybrid Capacitors QuickSpecs:

https://www.hpe.com/psnow/doc/a00028553enw.pdf?jumpid=in_pdp-psnow-qs

Subtopics

[Minimum firmware versions](#)

Minimum firmware versions

Product	Minimum firmware version
Server system ROM	1.20
HPE MR type-o and type-p Gen11 controllers	52.22.3-4650
HPE SR900 series type-p Gen11 controllers	03.01.14.062

Installing an energy pack

Prerequisites

- [Make sure that a compatible type-p storage controller is installed.](#)
- Make sure that you have the following items available:
 - Storage controller backup power cable (ships with the storage controller)
 - Energy pack extension cable (P58199-B21)
- If you are installing the HPE Smart Storage Hybrid Capacitor, [verify that the system meets the minimum firmware version requirements.](#)

Procedure

1. [Power down the server.](#)
2. Remove all power:
 - a. Disconnect each power cord from the power source.
 - b. Disconnect each power cord from the server.

3. Disconnect all peripheral cables from the server.
4. Do one of the following:
 - If the server is in tower mode, place the server on a flat, level surface with the access panel facing up.
 - If the server is in rack mode, remove the server from the rack.
5. Unlock the front bezel.
6. Remove the access panel.
7. If installed, remove the HPE NS204i-u Boot Device.
8. Connect the energy pack extension cable to the energy pack cable.
9. Install the energy pack:
 - a. Insert the energy pack at an angle.
 - b. Push the energy pack down from the other end.

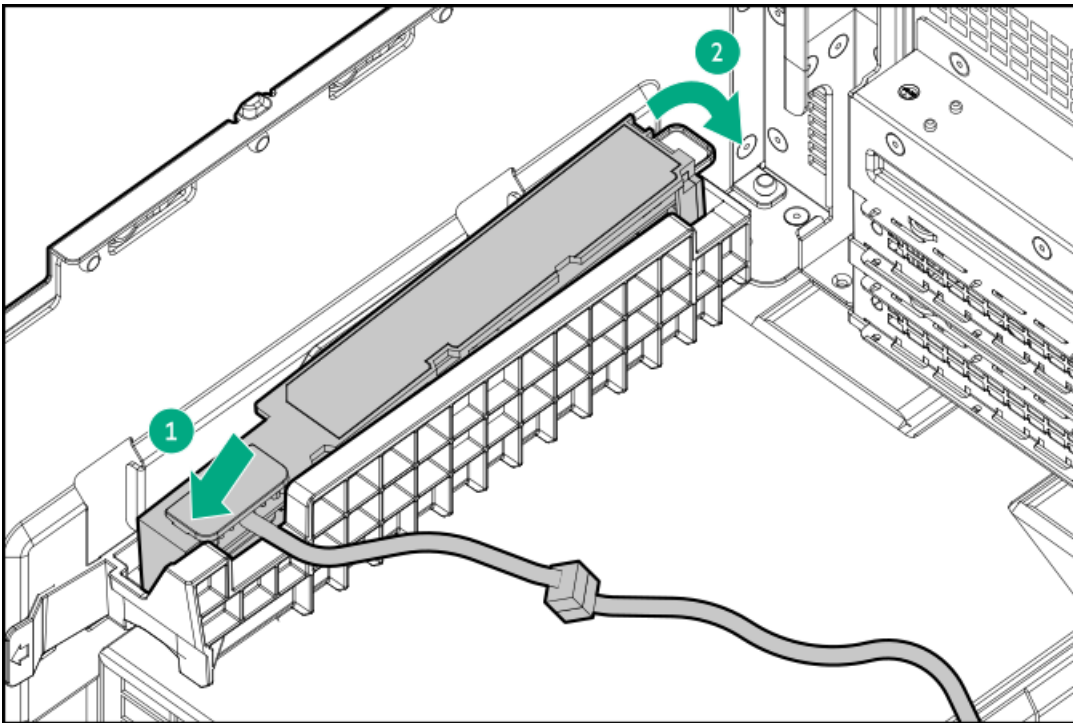

10. Connect the energy pack extension cable to the system board.
11. Connect the storage backup power cable.
12. If removed, install the HPE NS204i-u Boot Device.
13. Install the access panel.
14. Lock the front bezel.
15. Do one of the following:
 - Orient the server back in tower mode.
 - Install the server into the rack.
16. Connect all peripheral cables to the server.
17. Connect each power cord to the server.
18. Connect each power cord to the power source.



19. Power up the server.

Results

The installation is complete.

Expansion card options

The server supports the installation of full-height, full-length, and full-height, half-length PCIe expansion / add-in (AIC) cards such as:

- HPE type-p storage controller
- Ethernet adapter
- HDR InfiniBand adapter
- Fibre channel host bus adapter (FC HBA)
- Accelerator (workload, computational, or graphics accelerator)

For more information on the expansion options validated for this server, see the server QuickSpecs on the Hewlett Packard Enterprise website:

<https://www.hpe.com/info/quickspecs>

Subtopics

[Accelerator options](#)

[Installing an expansion card on the primary/secondary riser cage](#)

[Installing an expansion card on the tertiary riser](#)

Accelerator options

This server supports various accelerator options to meet your computational and graphics workload requirements. For a list of supported accelerator models, see the server QuickSpecs on the Hewlett Packard Enterprise website (<https://www.hpe.com/info/quickspecs>).

- PCIe workload accelerators—These options are PCIe card-based, direct-attach solutions that use solid-state storage technology directly on the PCI bus to boost I/O performance and reduce latency to scale in line with your processing requirements.
- Computational and graphics accelerators—These options deliver accelerated compute performance for a range of deep learning, high-performance computing (HPC), and graphics-intensive applications.

Subtopics

[Accelerator installation guidelines](#)

Accelerator installation guidelines

- To support high power accelerators (TDP > 75 W), the following options are required:
 - [PCIe5 2 x16 riser option in the primary or secondary locations](#).

Up to two accelerators are supported in each riser cage.

- GPU auxiliary power cable option (P47221-B21).
- This server does not support the installation of different accelerator models in the same system.
- To maintain proper system cooling, all eight internal fans are required for accelerator installation.
- For additional cooling support when a high power accelerator is installed, Hewlett Packard Enterprise highly recommends installing the [external GPU fan option \(P47220-B21\)](#).
- The limited operating inlet ambient temperatures required for accelerators vary based on the model and the server drive configuration. For more information, see the server QuickSpecs on the Hewlett Packard Enterprise website (<https://www.hpe.com/info/quickspecs>).

i **IMPORTANT:** Workloads for high performance double-width accelerators with passive cooling can cause the internal fans to operate at high speeds to maintain optimum system cooling. Hewlett Packard Enterprise does not recommend operating the server under this passive cooling condition in or near a site where there is a reasonable expectation for a quiet environment.

Installing an expansion card on the primary/secondary riser cage

Prerequisites

- If installing the HPE InfiniBand HDR100 / Ethernet 100 GB 2-port QSFP56 PCIe4 x16 Adapter, review the [Limited operating inlet ambient temperature requirements](#)
- When installing an accelerator, review the [Accelerator installation guidelines](#).
- Before you perform this procedure, make sure that you have a T-10 Torx screwdriver available.

About this task

⚠ CAUTION: A discharge of static electricity from a finger or other conductor might damage system boards or other static-sensitive devices. To prevent damage, observe [antistatic precautions](#).

⚠ CAUTION: To prevent improper cooling and thermal damage, do not operate the server unless all PCIe slots have either a riser slot blank or an expansion card installed.

Procedure

1. [Power down the server](#).
2. Remove all power:
 - a. Disconnect each power cord from the power source.
 - b. Disconnect each power cord from the server.
3. Disconnect all peripheral cables from the server.
4. Do one of the following:
 - If the server is in tower mode, [place the server on a flat, level surface with the access panel facing up](#).
 - If the server is in rack mode, [remove the server from the rack](#).
5. Unlock the front bezel.
6. [Remove the access panel](#).
7. Do one of the following:
 - [Remove the primary riser cage](#).
 - If installed, [remove the secondary riser cage](#).

8. Remove the riser slot blank:
 - a. Simultaneously push and rotate to open the riser cage latch.
 - b. Remove the screw and the riser slot blank.

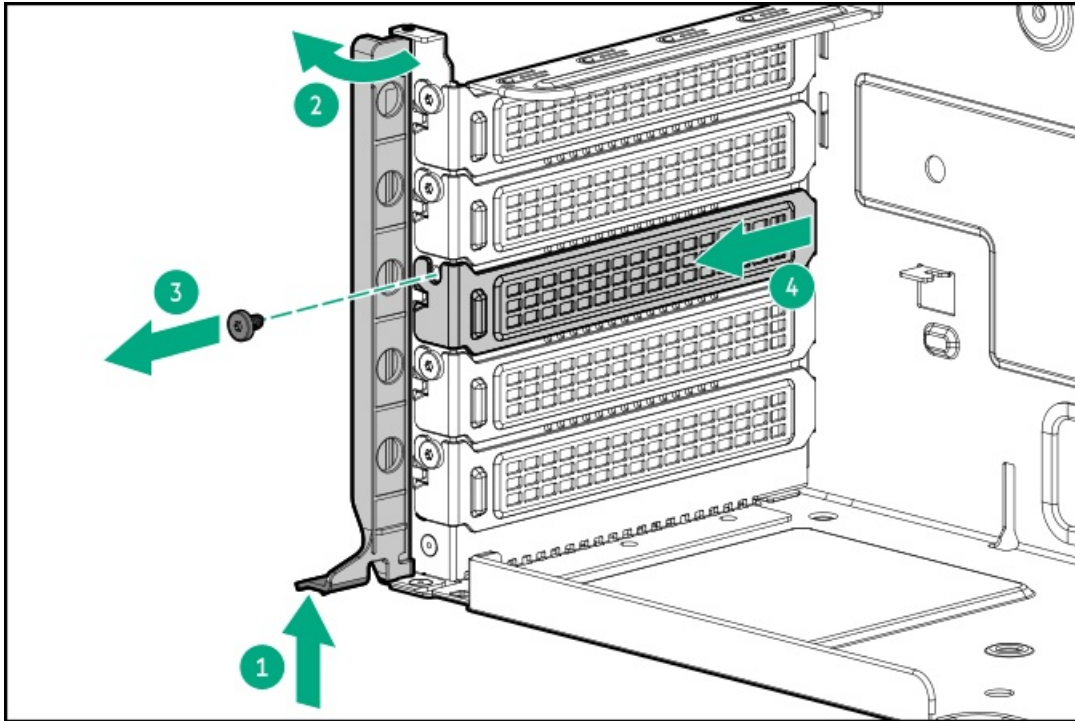

9. Make sure that any switches or jumpers on the expansion card are set properly.
For more information, see the documentation that ships with the expansion card option.

10. Install the expansion card:
 - a. Install the expansion card, and install the screw.
Make sure that the expansion card is seated firmly in the slot.
 - b. Simultaneously push and rotate to close the riser cage latch.

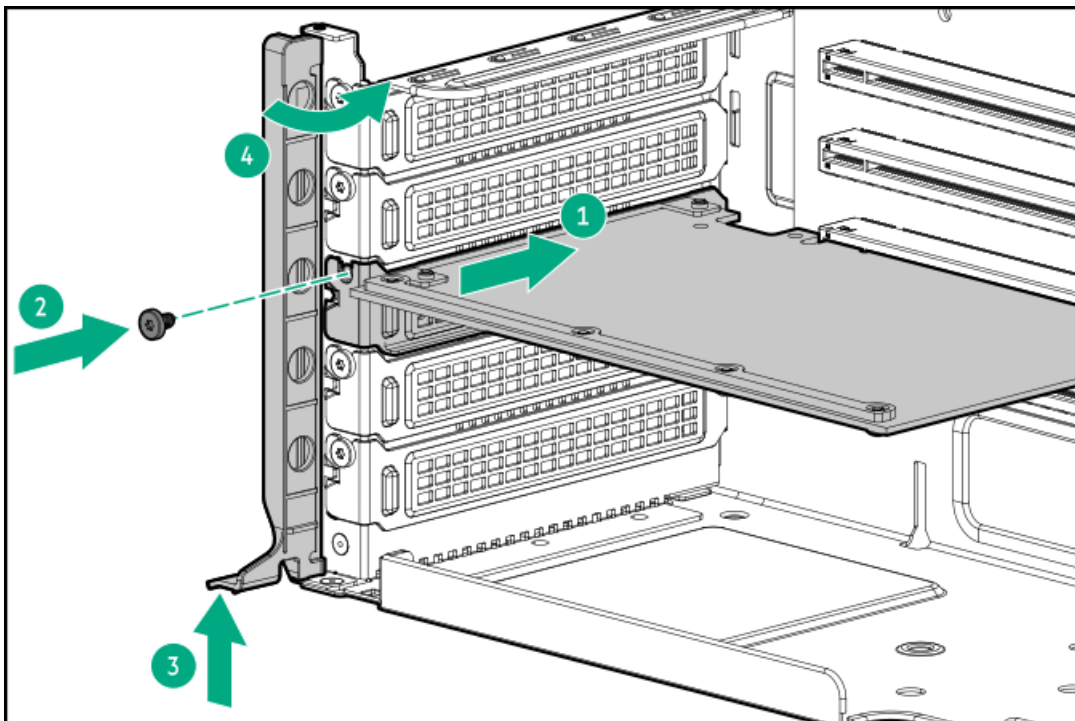

11. Connect all necessary internal cabling to the expansion card.
If a high power accelerator is installed, connect the GPU auxiliary power cable.
12. Install the riser cage.
13. Install the access panel.
14. Lock the front bezel.
15. Do one of the following:
 - Orient the server back in tower mode.
 - Install the server into the rack.
16. Connect all peripheral cables to the server.
17. Connect each power cord to the server.
18. Connect each power cord to the power source.
19. Power up the server.

Results

The installation is complete.

Installing an expansion card on the tertiary riser

Prerequisites

- Make sure that the server is in a dual-processor configuration.
- Before you perform this procedure, make sure that you have the following items available:
 - T-10 Torx screwdriver
 - Phillips No. 1 screwdriver

About this task

 **CAUTION:** A discharge of static electricity from a finger or other conductor might damage system boards or other static-sensitive devices. To prevent damage, observe antistatic precautions.

 **CAUTION:** To prevent improper cooling and thermal damage, do not operate the server unless all PCIe slots have either a riser slot blank or an expansion card installed.

Procedure

1. Power down the server.
2. Remove all power:
 - a. Disconnect each power cord from the power source.
 - b. Disconnect each power cord from the server.
3. Disconnect all peripheral cables from the server.
4. Do one of the following:
 - If the server is in tower mode, place the server on a flat, level surface with the access panel facing up.
 - If the server is in rack mode, remove the server from the rack.

5. Unlock the front bezel.
6. Remove the access panel.
7. If installed, remove the boot device.
8. If installed, remove the energy pack:
 - a. Disconnect the energy pack extension cable from the system board.
 - b. Press and hold the release latch.
 - c. Lift one end of the energy pack and release it from the holder.

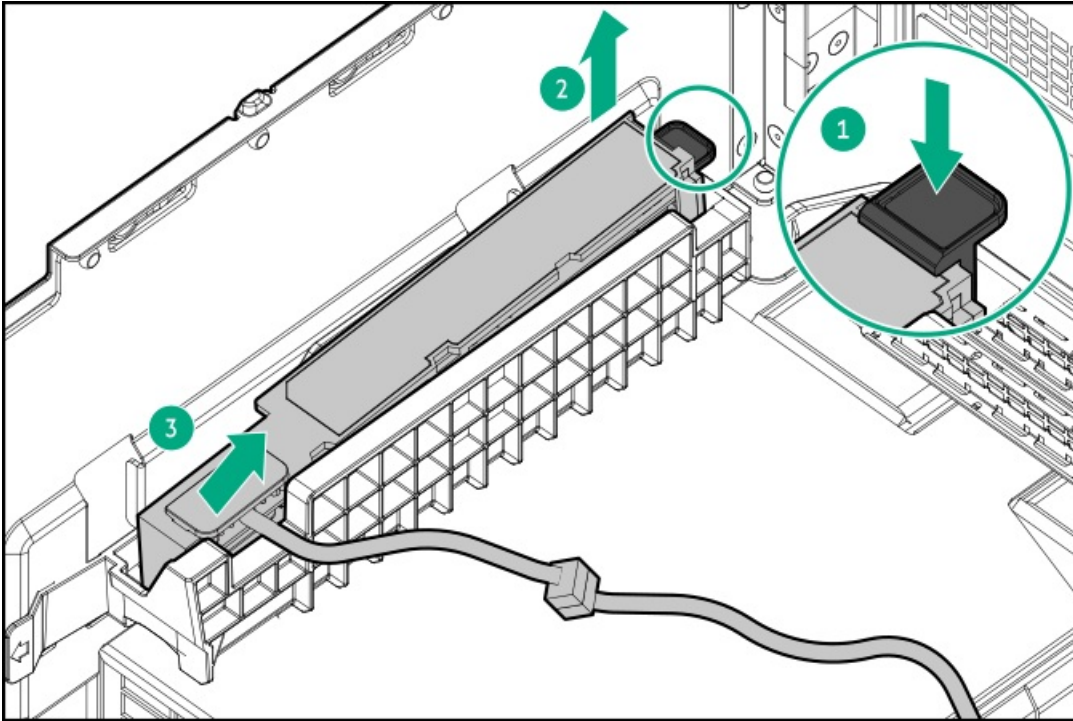

9. Remove the energy pack holder:
 - a. Press and hold the release latch on the holder.
 - b. Pull the holder towards the front panel to disengage from the chassis.

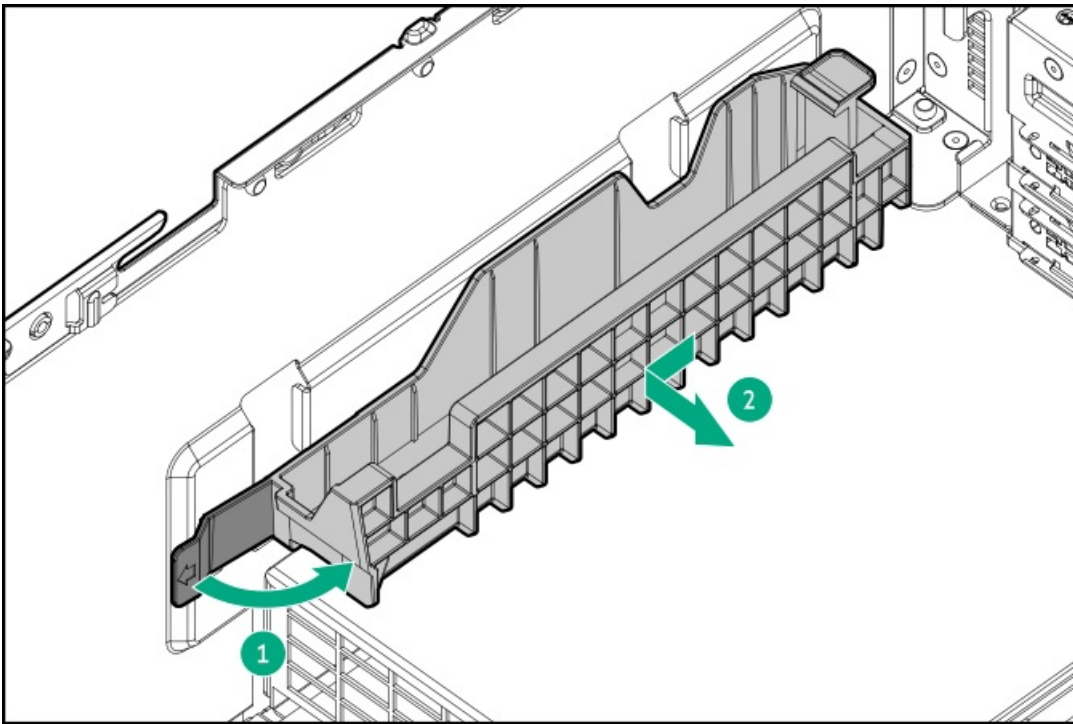

10. (Optional) Install the tertiary riser.
11. Remove the tertiary riser slot cover.

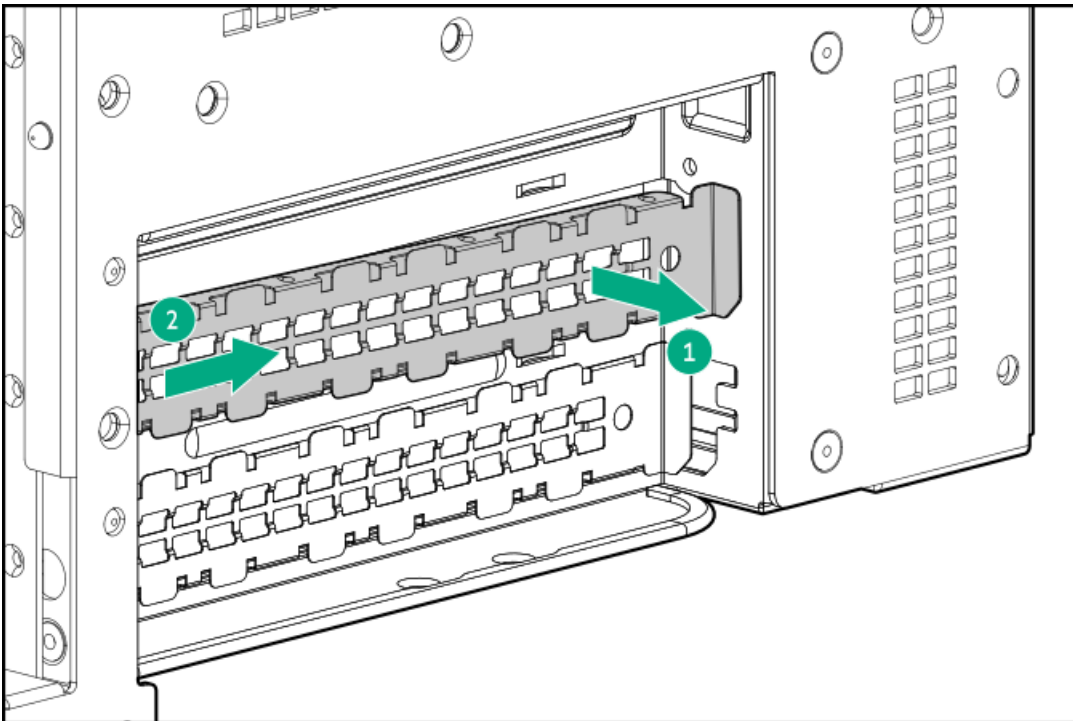

12. Make sure that any switches or jumpers on the expansion card are set properly.
For more information, see the documentation that ships with the expansion card option.
13. Install the expansion card.



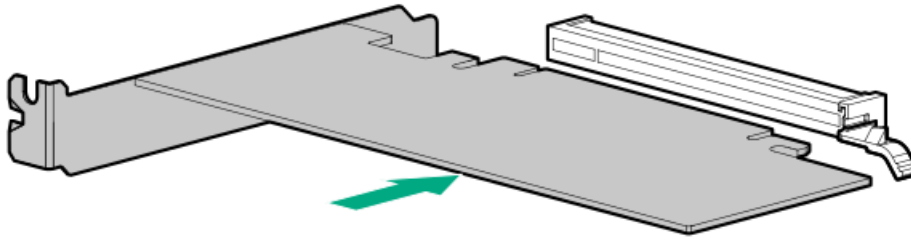

14. Install the stabilizer bracket to secure the expansion card:
 - a. Press down the stabilizer bracket onto the expansion card.
 - b. Tighten the captive screw.

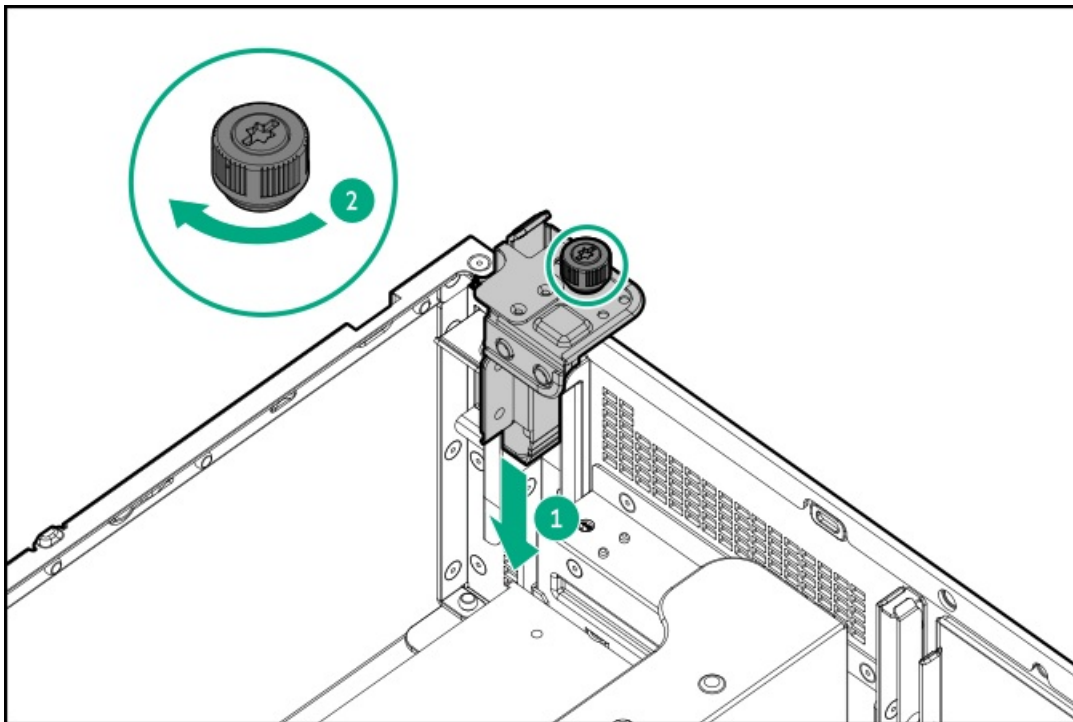

15. Connect all necessary internal cabling to the expansion card.
For more information on these cabling requirements, see the documentation that ships with the option.
16. Install the energy pack holder.

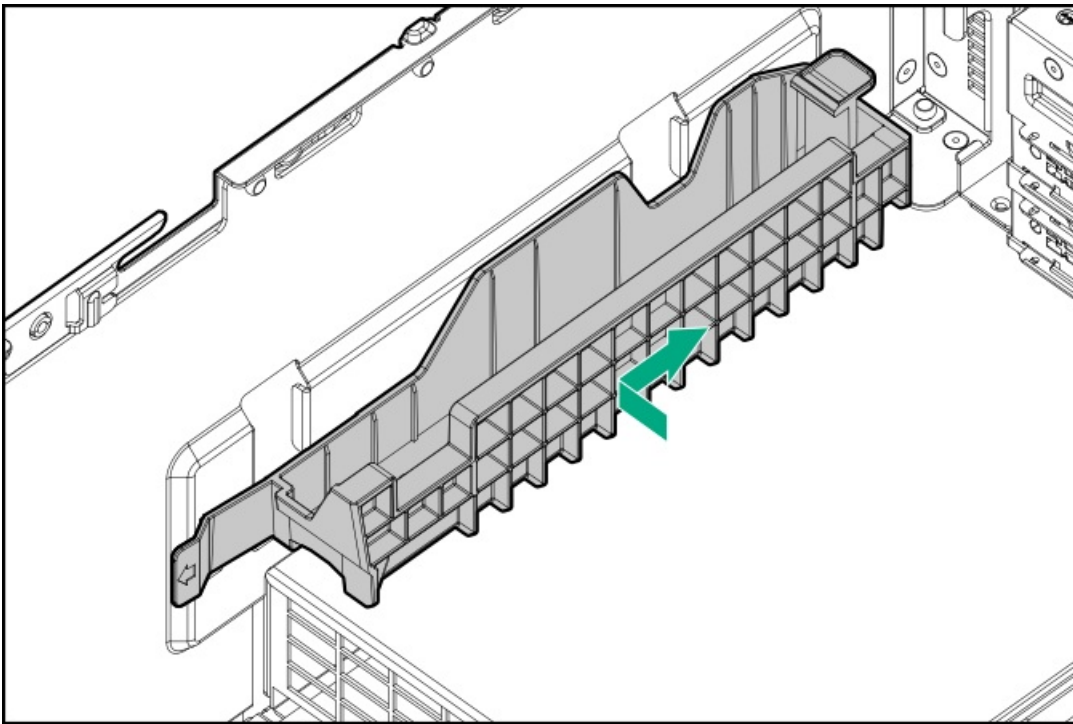

17. If removed, install the following components:

- [The energy pack](#)
- [The boot device](#)

18. [Install the access panel.](#)

19. Lock the front bezel.

20. Do one of the following:

- [Orient the server back in tower mode.](#)
- [Install the server into the rack.](#)

21. Connect all peripheral cables to the server.

22. Connect each power cord to the server.

23. Connect each power cord to the power source.

24. [Power up the server.](#)

Results

The installation is complete.

Processor heatsink assembly option

Subtopics

[Processor cautions](#)

[Installing the processor heatsink assembly](#)

Processor cautions

PROCESSOR CAUTIONS

CAUTION: To avoid damage to the processor or system board, only authorized personnel should attempt to replace or install the processor in this server.

CAUTION: To prevent possible server malfunction and damage to the equipment, multiprocessor configurations must contain processors with the same part number.

CAUTION: The pins on the processor socket and on the processor are very fragile and easily damaged . To avoid component damage, **do not touch these pins**. Any damage to them might require replacing the system board and/or processor.

IMPORTANT: Processor socket 1 must be populated at all times or the server does not function.

IMPORTANT: If installing a processor with a faster speed, update the system ROM before installing the processor. To download firmware, see [Updating firmware or system ROM](#).

Installing the processor heatsink assembly

Prerequisites

Before performing this procedure:

- [Make sure that the compatible fans are installed](#).
- Make sure that you have a T-30 Torx screwdriver available.

About this task

This server supports two heatsink options:

- Standard heatsink (P47223-B21)
- Performance heatsink (P47224-B21)

Processors with TDP equal to or greater than 195 W require performance heatsinks.

Procedure

1. [Power down the server](#).
2. Remove all power:
 - a. Disconnect each power cord from the power source.
 - b. Disconnect each power cord from the server.
3. Disconnect all peripheral cables from the server.
4. Do one of the following:
 - If the server is in tower mode, [place the server on a flat, level surface with the access panel facing up](#).
 - If the server is in rack mode, [remove the server from the rack](#).
5. Unlock the front bezel.
6. [Remove the access panel](#).
7. [Remove the fan cage](#).
8. [Remove the secondary riser cage](#).
9. Remove the protective film from the thermal interface material.

CAUTION: To prevent mechanical damage or depositing oil on your hands or other contaminants to the heatsink contact surface, hold the heatsink only by the edge of its base plate. Do not touch the heatsink fins.

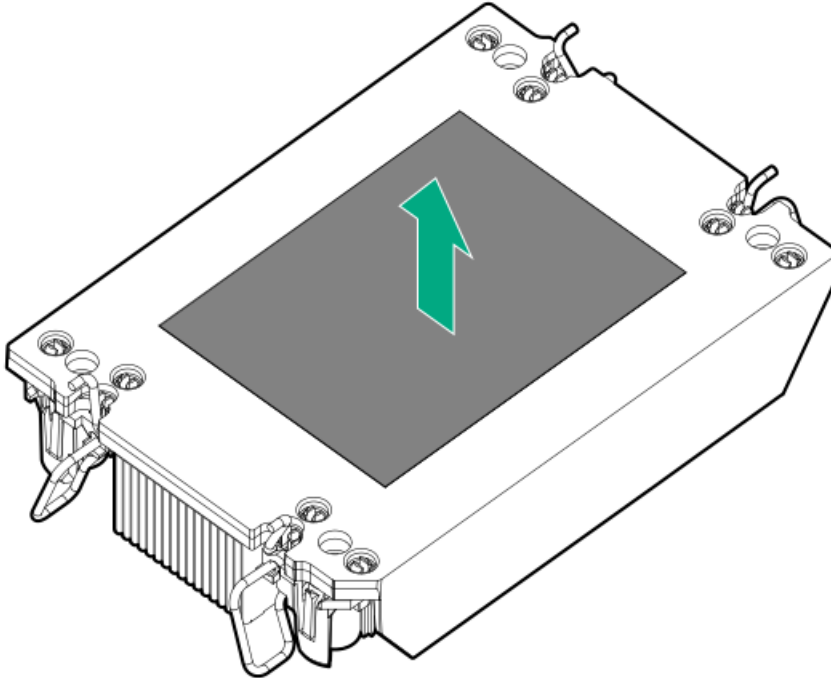

10. Set the anti-tilt wires to the locked position.

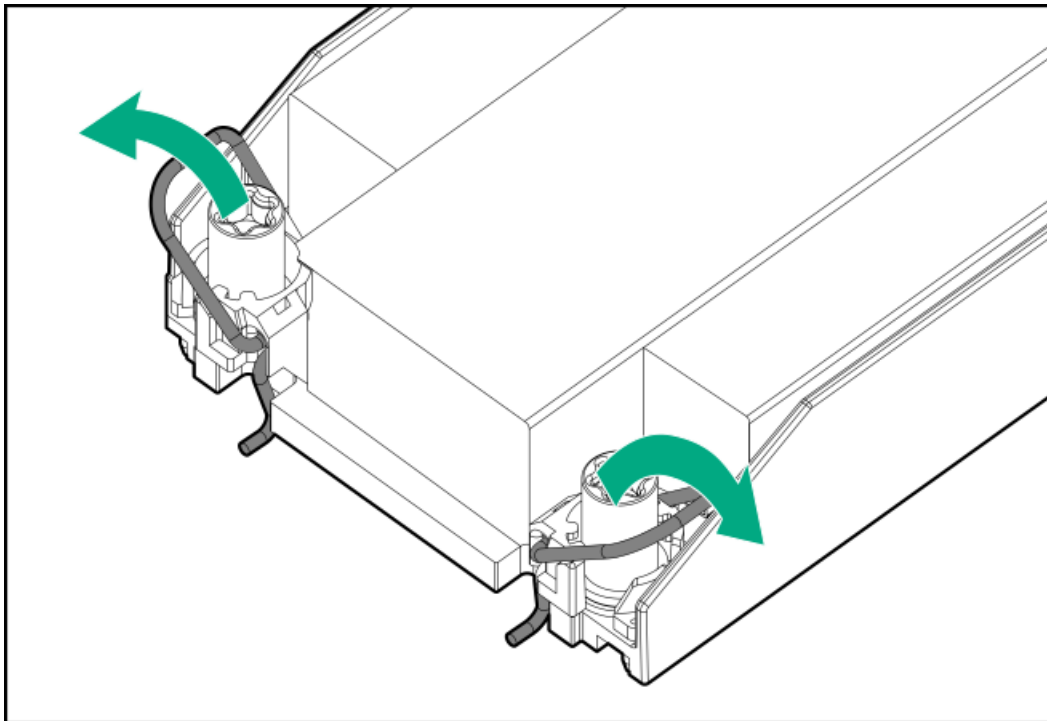

11. Verify that the processor is securely latched to the processor carrier.

The following illustration calls out the keying feature tabs that secure the processor. Different processor carriers will have these tabs in different locations.



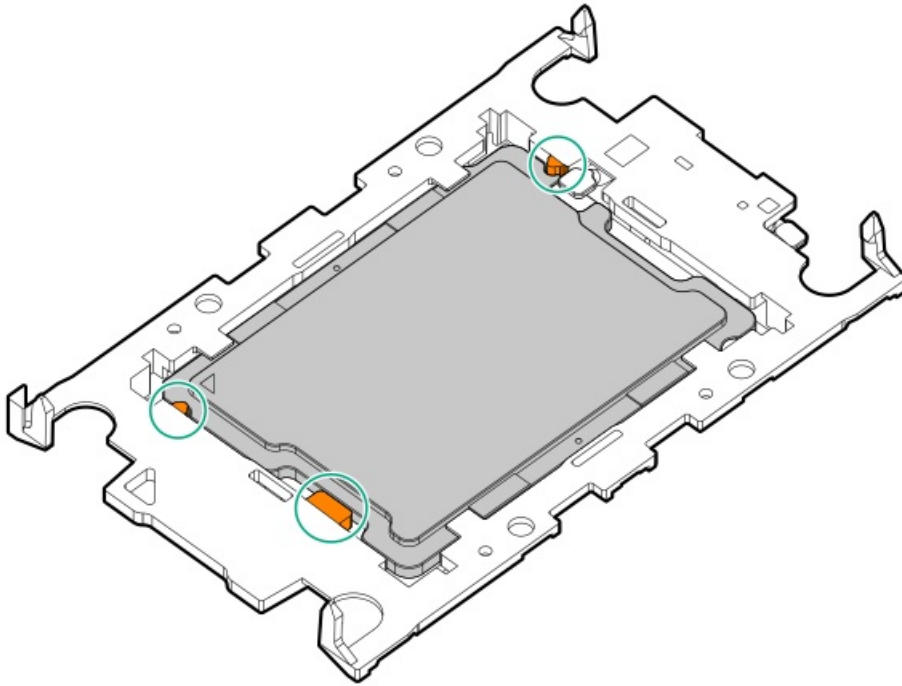

12. Attach the heatsink to the processor carrier:

- a. Align the pin 1 indicator on the processor carrier with that on the heatsink.

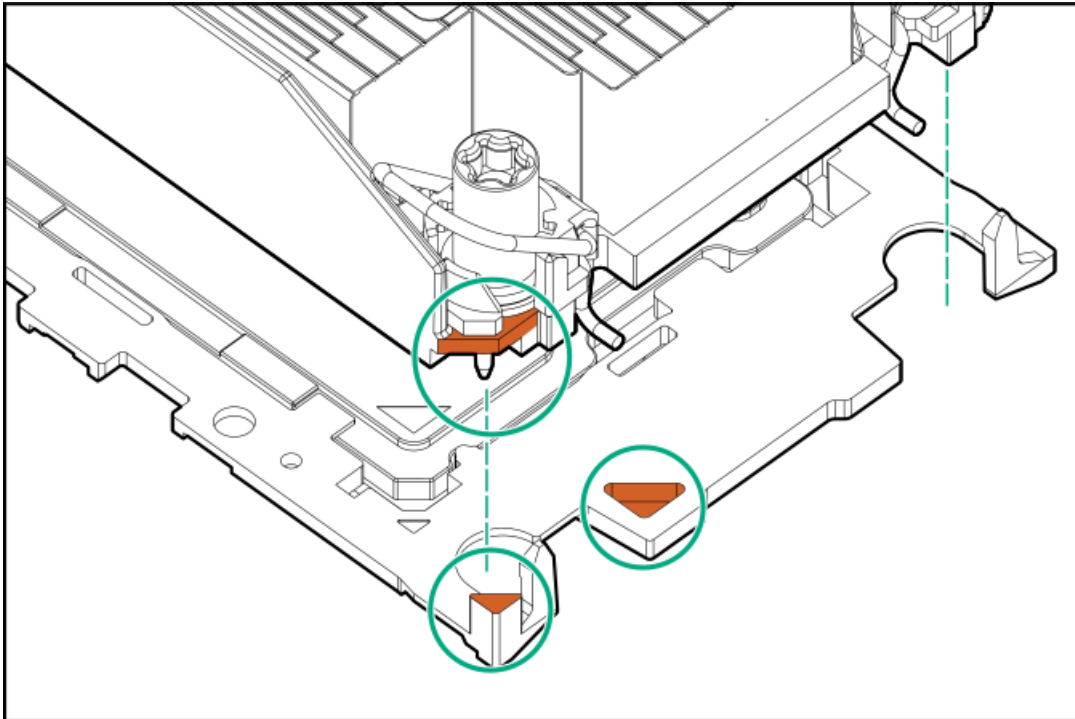

- b. Lower the heatsink on the processor carrier until the carrier tabs snap into place.

There will be an audible click to indicate that the heatsink is properly latched on the processor carrier.

- Standard heatsink



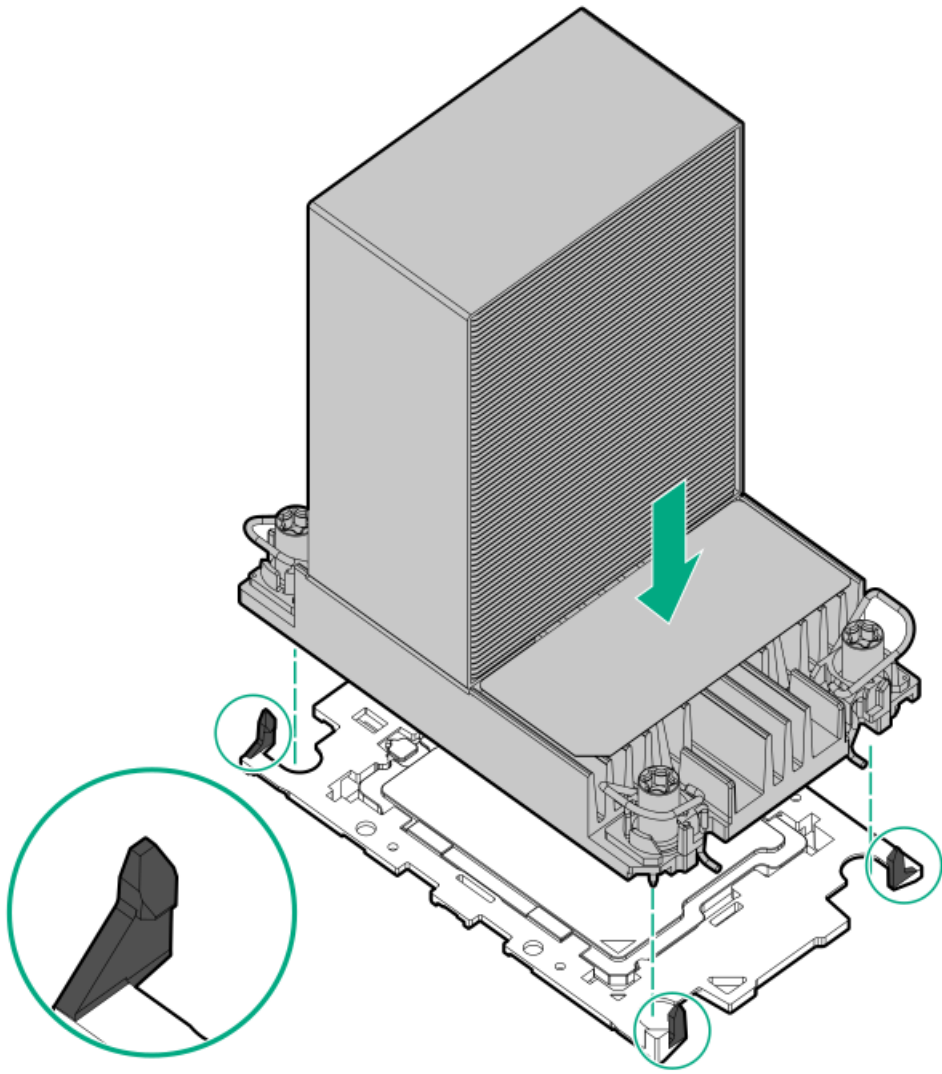

- Performance heatsink

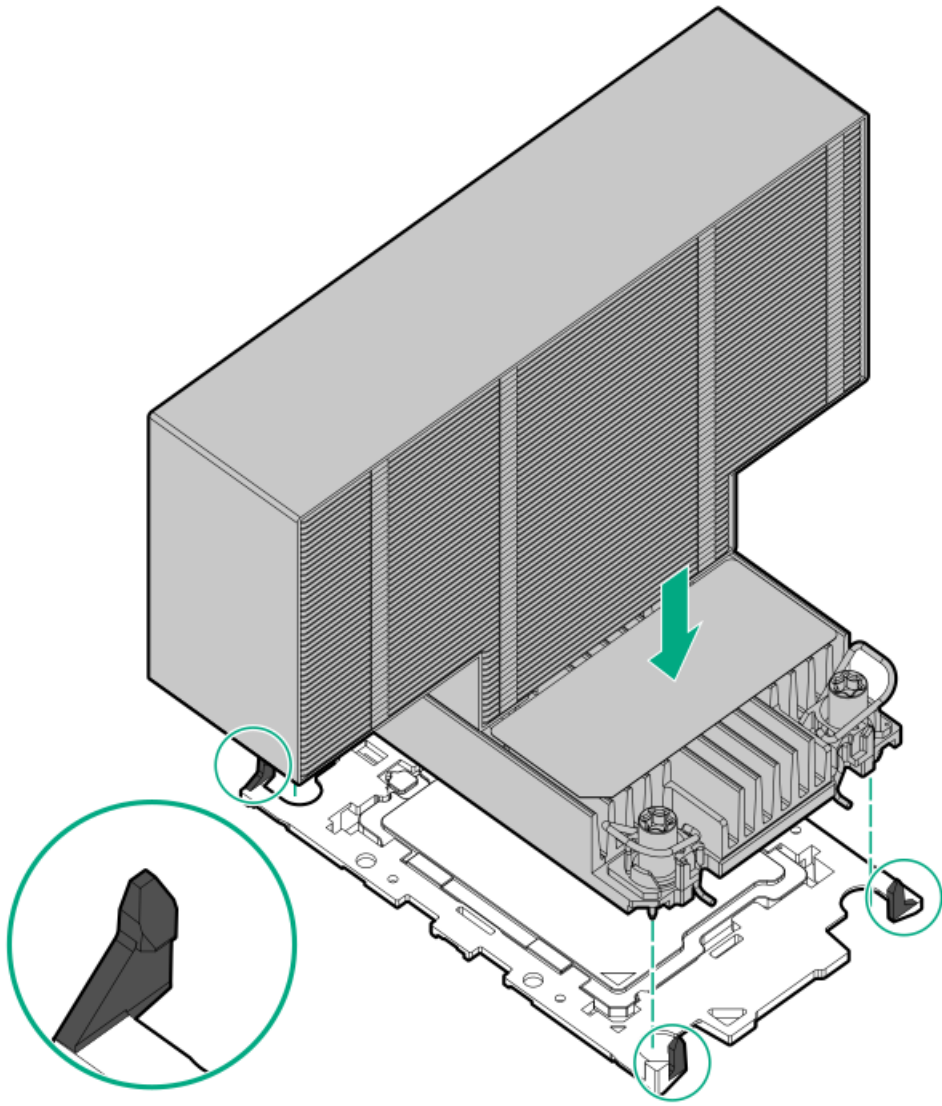

13. Perform the following verification steps:

- a. Verify that the tabs on the processor carrier are securely latched on the heatsink.

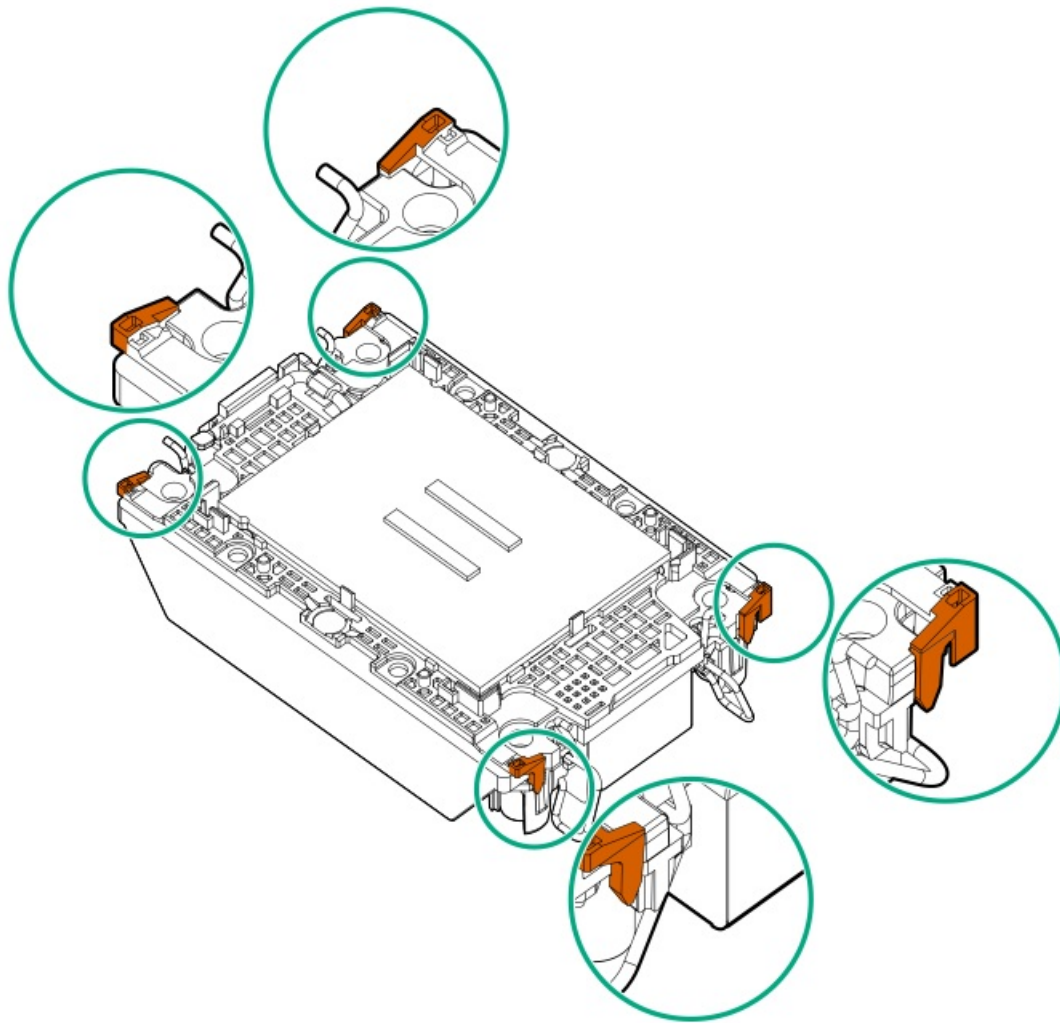

b. Verify that the pin 1 indicators on the processor and processor carrier are aligned.

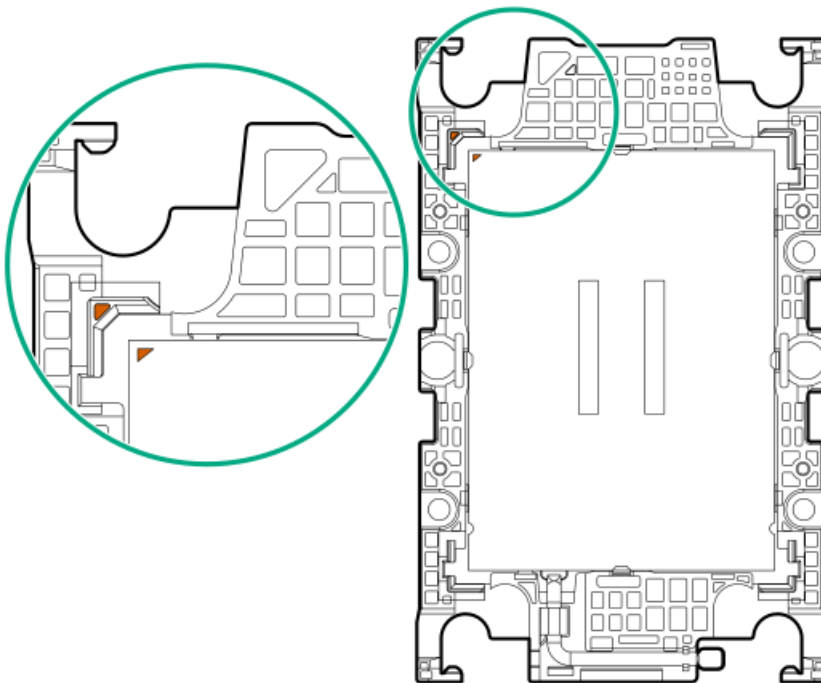

c. Verify that the processor is properly secured by the carrier snaps.



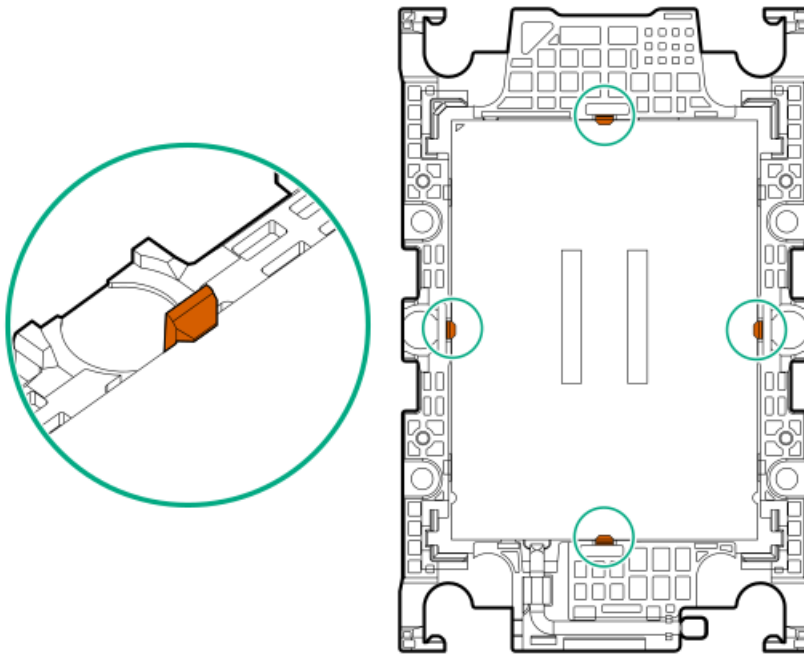

14. Remove the dust cover from the processor socket:

- a. Press and hold the grip tabs on the dust cover.
- b. Lift the dust cover away from the bolster plate.

Retain the cover for future use.

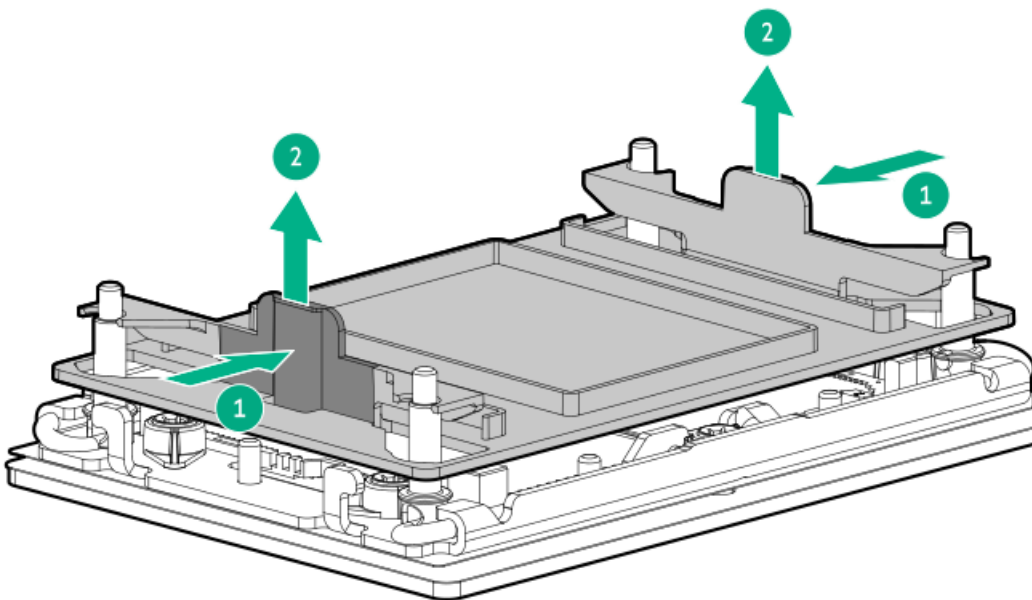

15.  **CAUTION:**

To prevent thermal failure or component damage, do not move the heatsink once the bottom of its base plate touches the top of the processor. Excessive heatsink movement can cause the thermal grease to smear and become uneven. Voids in the compound can adversely impact the transfer of heat away from the processor.

Install the processor-heatsink module:

- a. When using a torque wrench to tighten the heatsink screws, set 0.9 N-m (8 in-lb) of torque .
- b. Note the **Front of server** text on the heatsink label to correctly orient the processor-heatsink module over the bolster plate.

c. Carefully lower the processor-heatsink module straight down onto the bolster plate guide posts.

The posts are keyed so that the module can only be installed one way. Make sure that the module is properly seated on the bolster plate before securing the screws.

- Standard heatsink

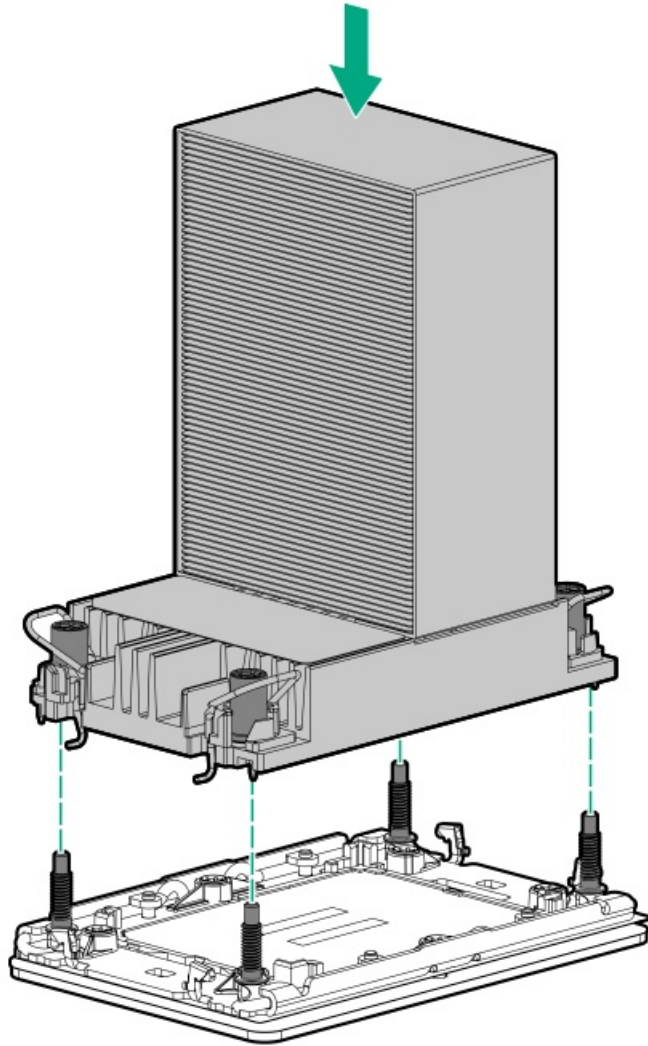

- Performance heatsink

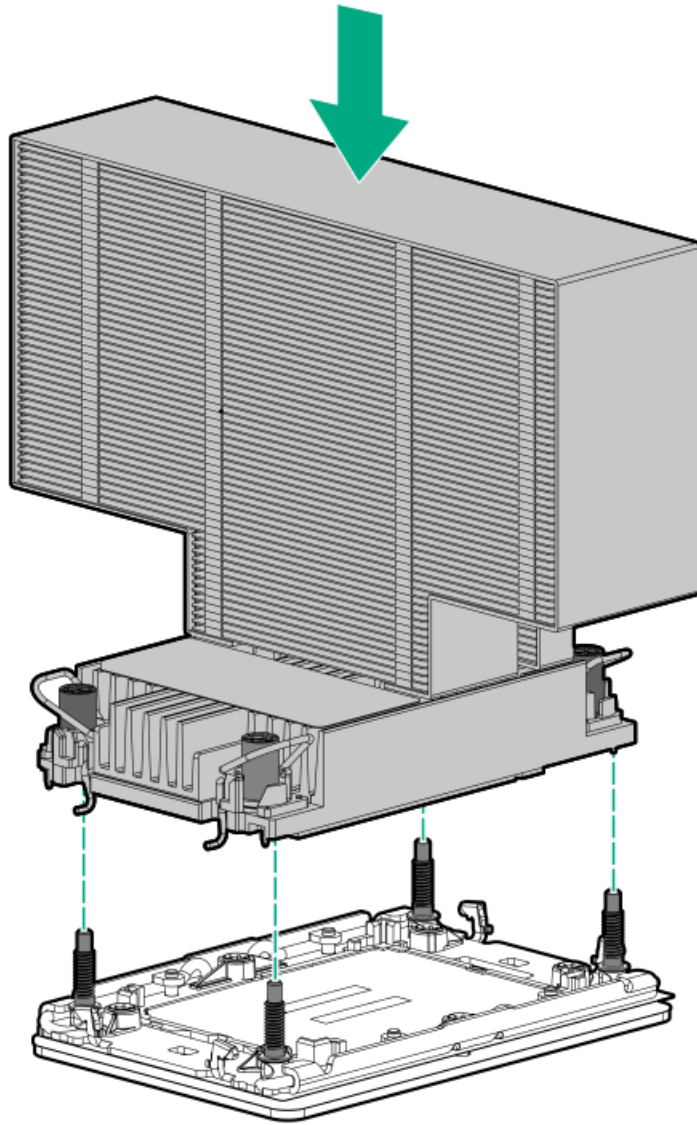

d. Set the anti-tilt wires to the locked position.

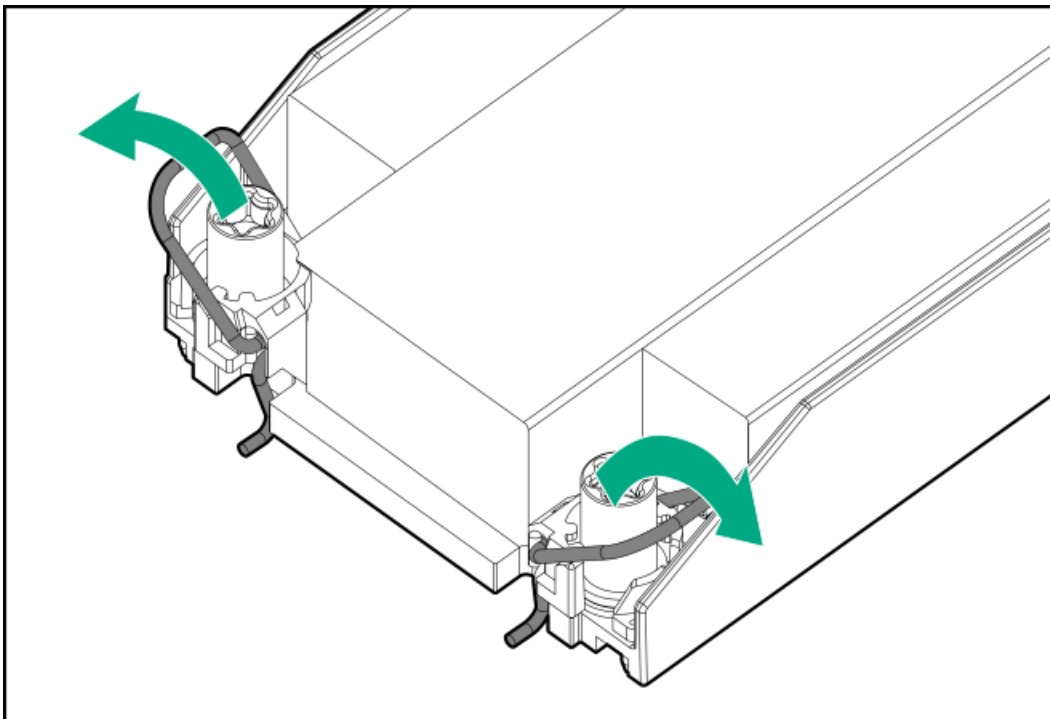

e. Tighten one pair of diagonally opposite heatsink screws, and then tighten the other pair of heatsink screws.

- Standard heatsink

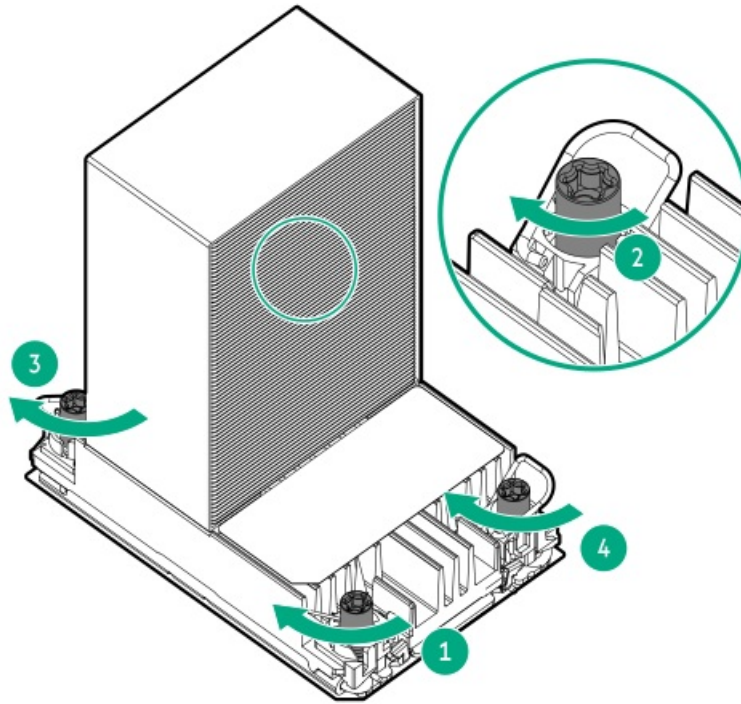

- Performance heatsink

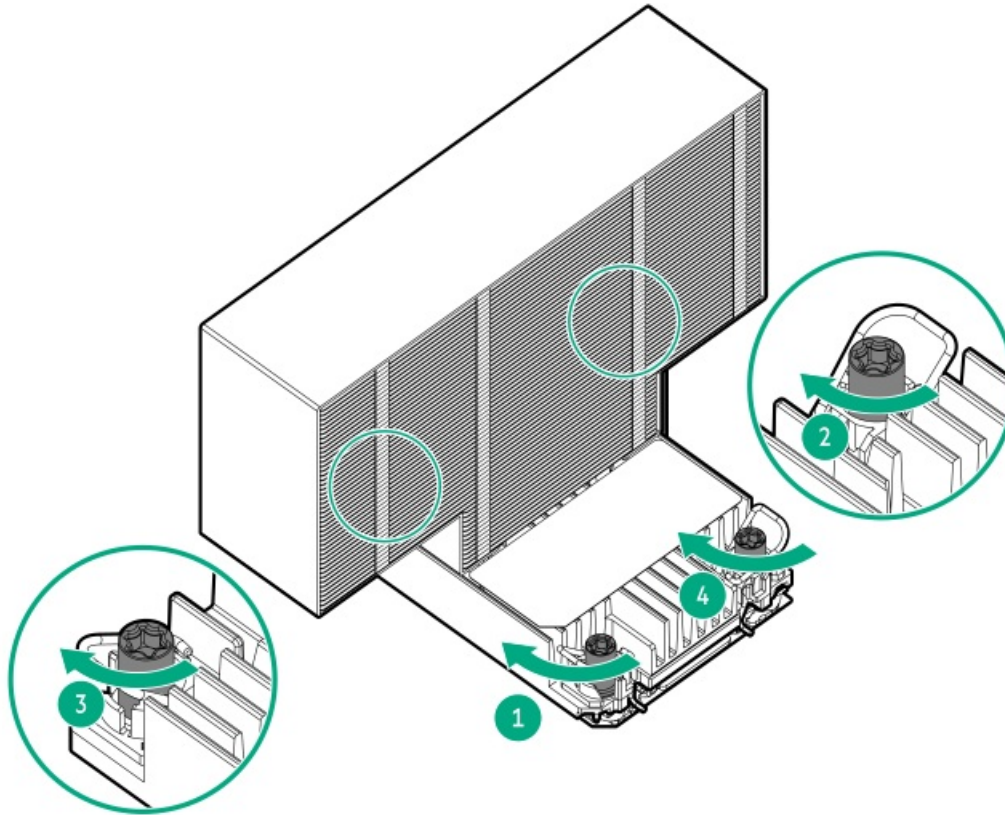

16. If installing the performance heatsink, remove the fan cage baffle from the fan cage.



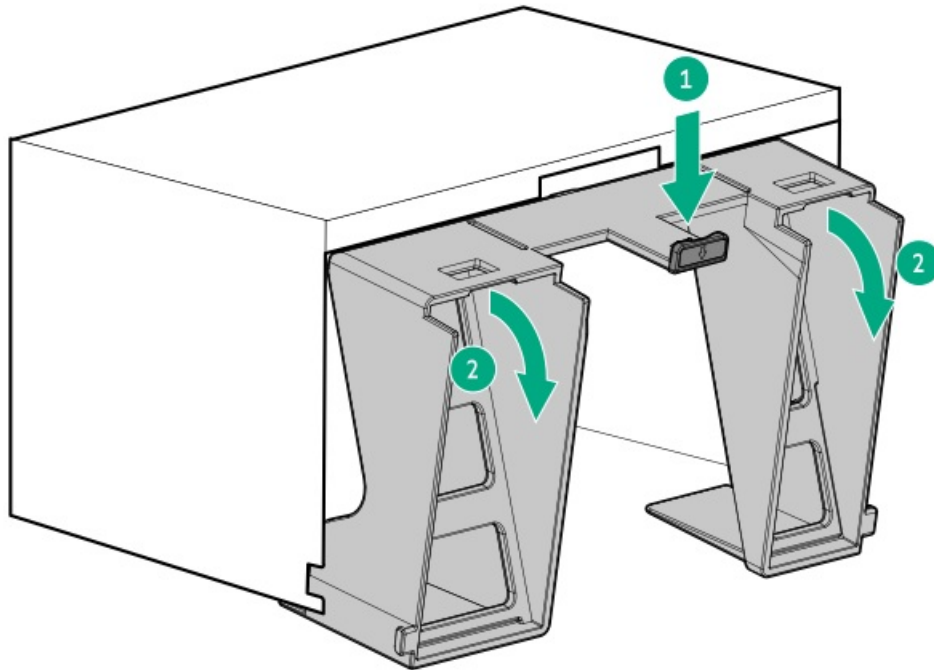

17. Install the fan cage.
18. Install the access panel.
19. Lock the front bezel.
20. Do one of the following:
 - Orient the server back in tower mode.
 - Install the server into the rack.
21. Connect all peripheral cables to the server.
22. Connect each power cord to the server.
23. Connect each power cord to the power source.
24. Power up the server.

Results

The installation is complete.

HPE NS204i-u Boot Device option

Note the following information about the HPE NS204i-u Boot Device option:

- The HPE NS204i-u Gen11 NVMe Hot Plug Boot Optimized Storage Device is a PCIe5 custom form factor module that includes two hot-pluggable 2280 M.2 NVMe SSDs.
- This boot device enables the deployed OS to be mirrored through a dedicated hardware RAID 1.
- The boot device auto-creates a RAID1 volume during boot. This means the boot device does not require further RAID configuration.
- This boot device is compatible with the following native OS:
 - Windows
 - Linux

- VMware
- This boot device uses native inbox OS NVMe drivers.

Subtopics

[NS204i-u enablement option](#)

[Installing the HPE NS204i-u Boot Device](#)

NS204i-u enablement option

This server supports the installation of the NS204i-u boot device on top of the power supply cage that requires the NS204i-u enablement option.

Kit contents

- Boot device baffle
- Boot device latch
- Boot device SlimSAS and power cables
- T-15 screws (3)

Installing the HPE NS204i-u Boot Device

Prerequisites

- Before you perform this procedure, make sure the following:
 - [Fan 1 is installed.](#)
 - The server is updated with the latest operating system firmware and drivers.
 - [Identify the HPE NS204i-u Boot Device components.](#)
 - Review the [Limited operating inlet ambient temperature requirements for HPE NS204i-u Boot Device](#) for a specific system operating temperature requirement.
- Before you perform this procedure, make sure that you have the following items available:
 - [NS204i-u enablement option kit](#)
 - T-10 Torx screwdriver
 - T-15 Torx screwdriver
 - Phillips No. 1 screwdriver

About this task

 **CAUTION:** A discharge of static electricity from a finger or other conductor might damage system boards or other static-sensitive devices. To prevent damage, observe [antistatic precautions](#).

 **CAUTION:** To prevent improper cooling and thermal damage, do not operate the server unless all bays are populated with either a component or a blank.

Procedure

Installing drives onto the boot device

1. Remove the boot device carrier:

- a. Press and hold the carrier latch.
- b. Pivot the latch to open.
- c. Slide the carrier out from the boot device cage.

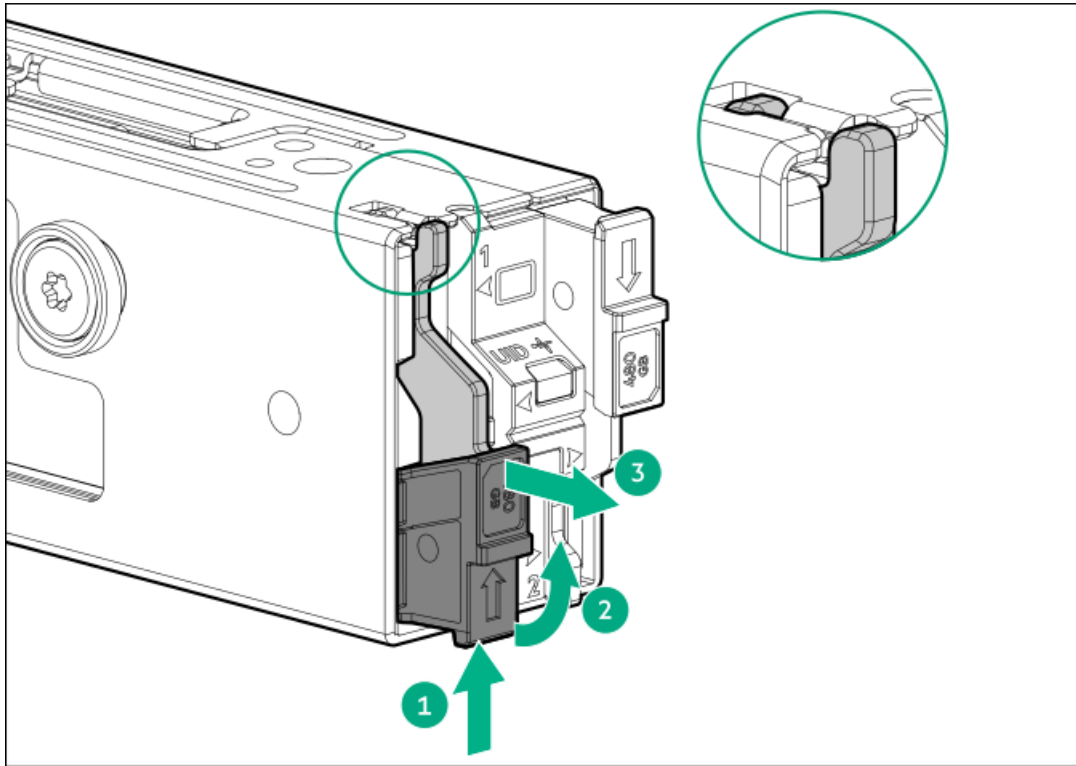

2. Install the SSD on the boot device carrier:

- a. Remove the SSD mounting screw.

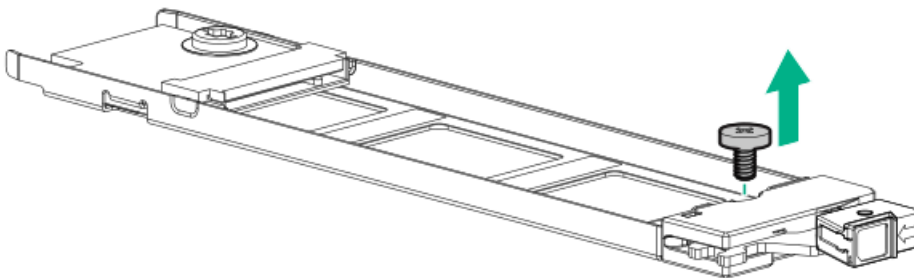

- b. Insert the SSD into the M.2 slot at a 45° angle.
- c. Carefully press the SSD down to the horizontal position.
- d. Install the SSD mounting screw.

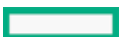

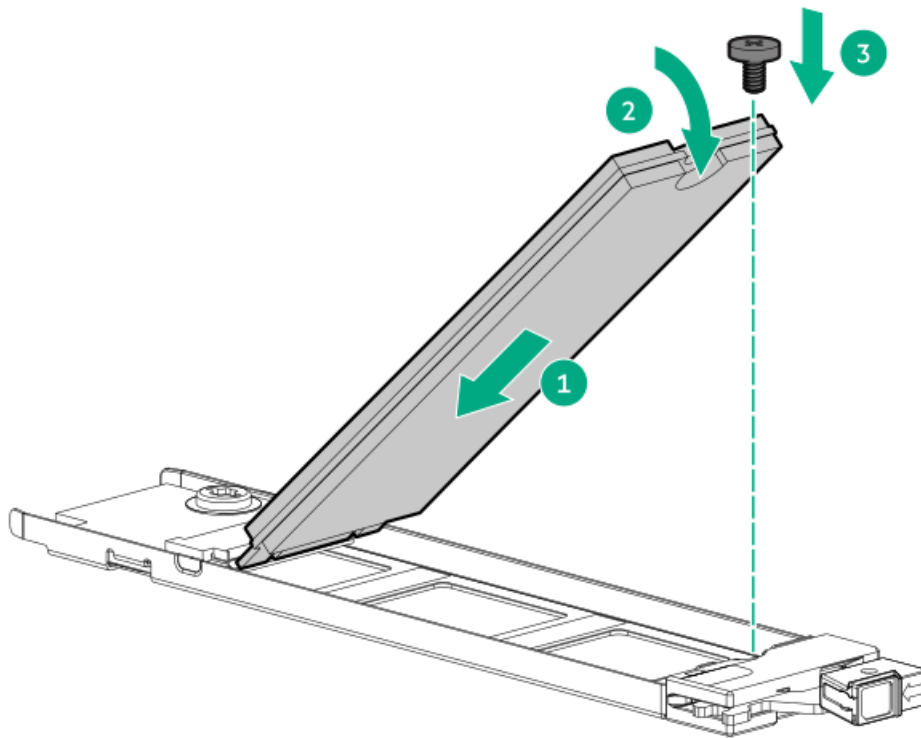

3. Install the boot device carriers:

- a. If closed, pivot the carrier latch to open.
- b. Slide the carrier into the boot device cage.
- c. Pivot the latch to close.

Make sure that the carrier latch is locked on the boot device cage.

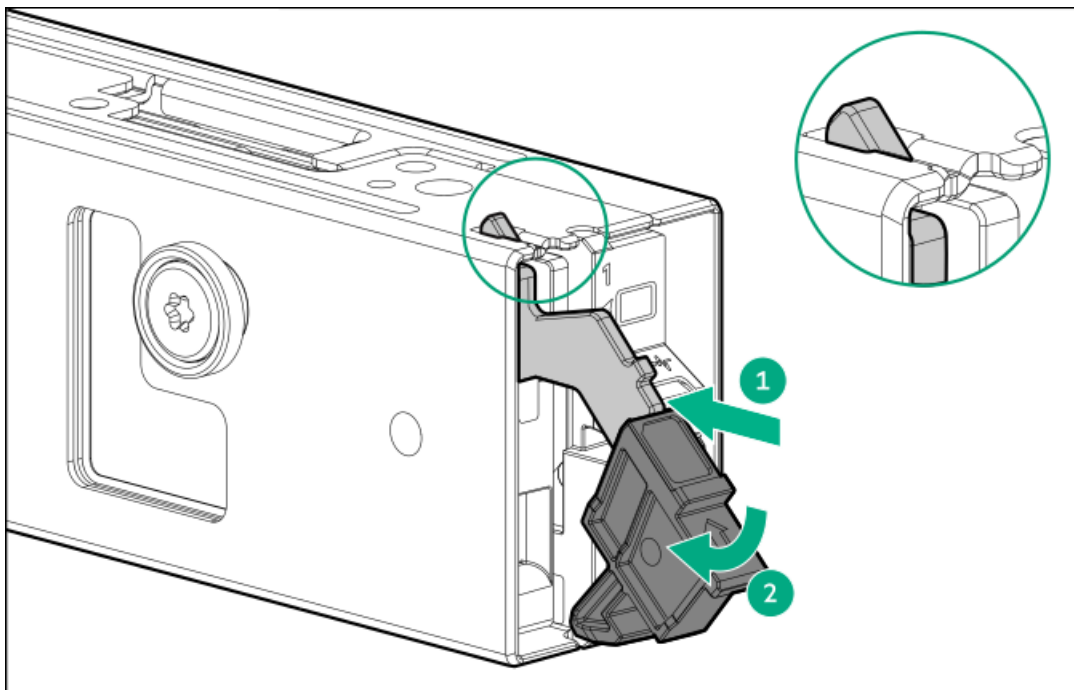

Installing the boot device

4. Power down the server.

5. Remove all power:

- a. Disconnect each power cord from the power source.



- b. Disconnect each power cord from the server.
6. Disconnect all peripheral cables from the server.
7. Do one of the following:
 - If the server is in tower mode, place the server on a flat, level surface with the access panel facing up.
 - If the server is in rack mode, remove the server from the rack.
8. Unlock the front bezel.
9. Remove the access panel.
10. Install the boot device latch:
 - a. Insert the boot device latch on the boot device.
 - b. Install the latch screw provided in the accessory bag.

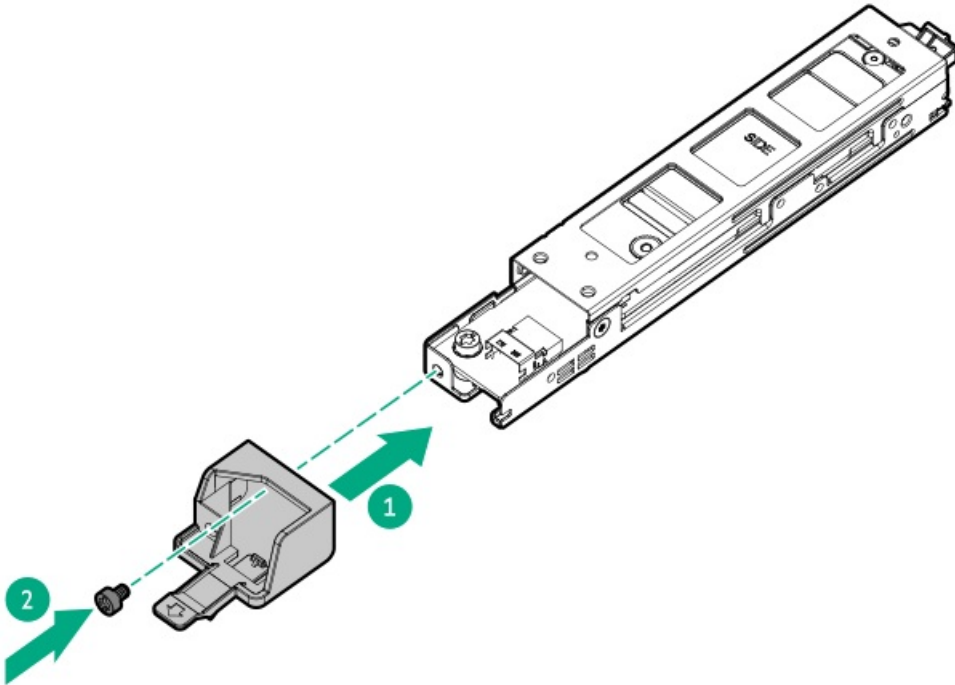

11. Install the boot device baffle:
 - a. Install the baffle on top of the boot device.
 - b. Install the boot device baffle screws provided in the accessory bag.

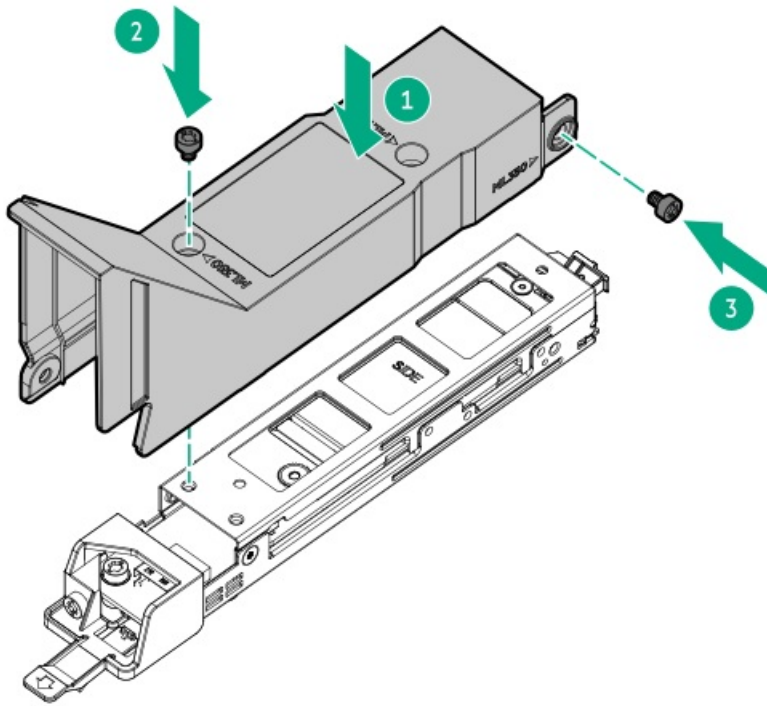

12. Connect the SlimSAS signal and power cables to the boot device.
13. Align the pins on the boot device with holes on the chassis side wall to slide the boot device.

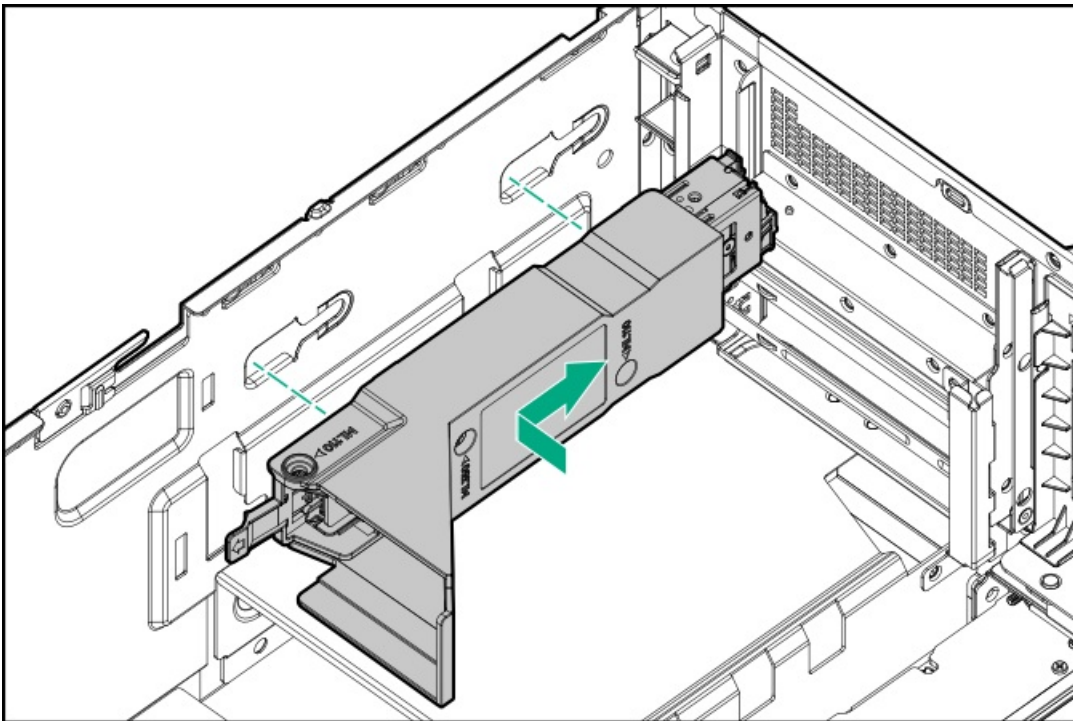

14. Connect the boot device signal and power cables to the system board.
15. To allow hot-plug access to the SSDs on the boot device, remove the security cover.

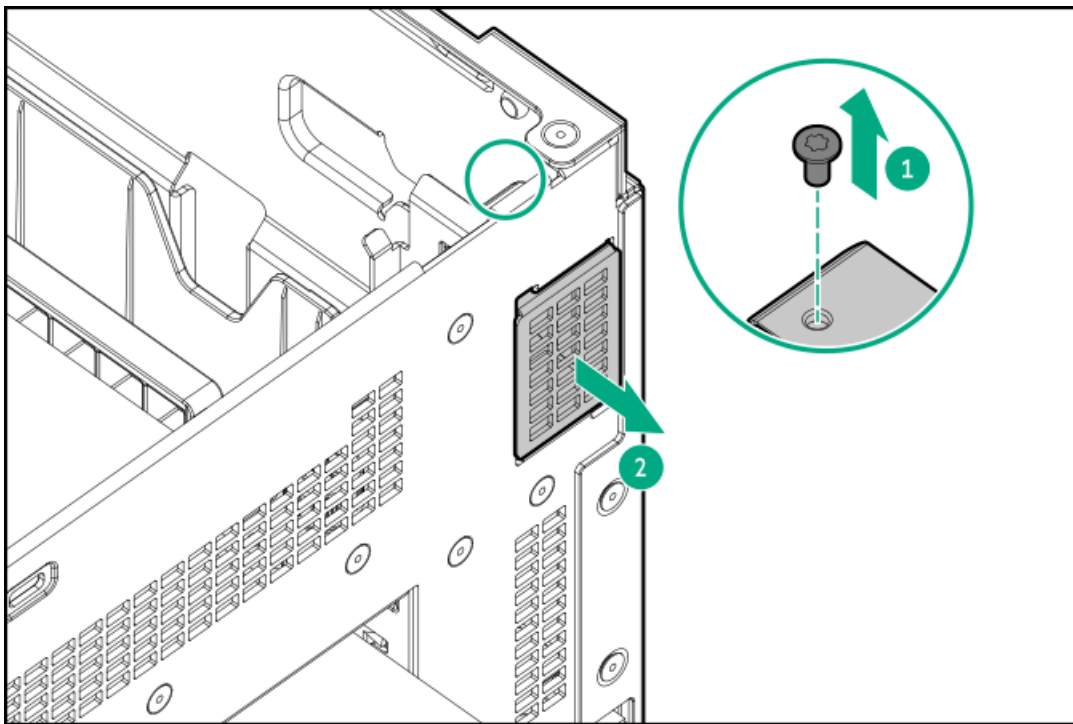

16. Install the access panel.
17. Lock the front bezel.
18. Do one of the following:
 - Orient the server back in tower mode.
 - Install the server into the rack.
19. Connect all peripheral cables to the server.
20. Connect each power cord to the server.
21. Connect each power cord to the power source.
22. Power up the server.

Results

The installation is complete.

OCP NIC 3.0 adapter option

The server supports SFF dual-port and quad-port OCP NIC 3.0 adapter options with various interfaces and advanced interconnect features for high-bandwidth applications.

Subtopics

[OCP slot population rules](#)

[Installing the OCP NIC 3.0 adapter](#)

OCP slot population rules



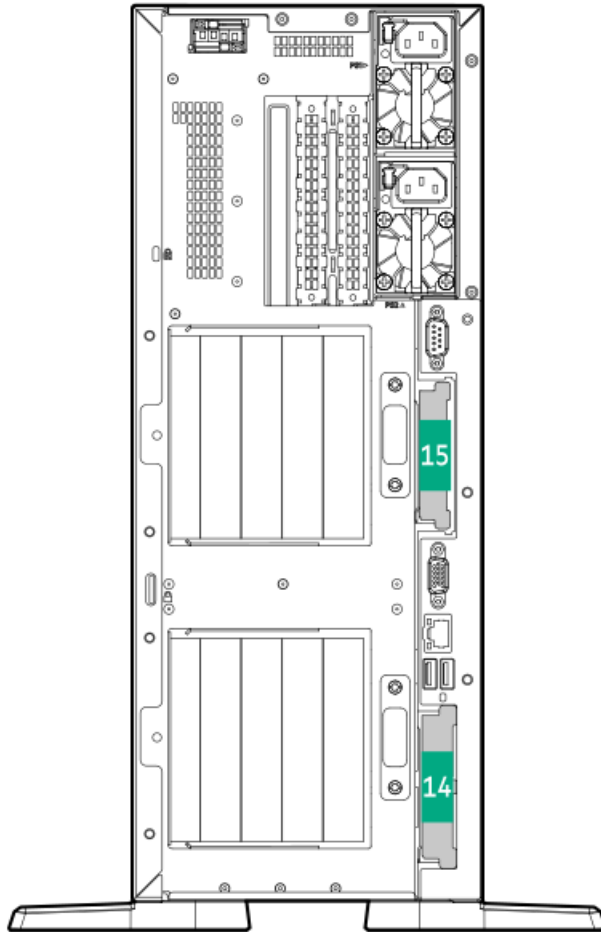

Slot number	Supported hardware components
Slot 14 OCP PCIe5 x8 ¹	Type-o storage controller OCP NIC adapter
Slot 15 OCP PCIe5 x8 ²	OCP NIC adapter

- ¹ Slot 14 does not support Wake on LAN (WOL) and shared NIC functions.
² When installing a single OCP NIC 3.0 adapter, install it in Slot 15.

Installing the OCP NIC 3.0 adapter

Prerequisites

- Review the [OCP slot population rules](#).
- Before you install an OCP NIC 3.0 adapter in OCP slot 15, make sure that [the server is in a dual-processor configuration](#).
- Before you perform this procedure, make sure that you have the following items available:
 - T-10 Torx screwdriver
 - Compatible OCP bandwidth upgrade cable:
 - OCP bandwidth upgrade cable for OCP slot 14 (P47230-B21)—This cable is required only if you are installing an OCP NIC 3.0 x16 adapter in the OCP slot 14



- OCP bandwidth upgrade cable for OCP slot 15 (P47231-B21)—This cable option kit is required only if you are installing an OCP NIC 3.0 adapter in the OCP slot 15

About this task

 **CAUTION:** A discharge of static electricity from a finger or other conductor might damage system boards or other static-sensitive devices. To prevent damage, observe antistatic precautions.

 **CAUTION:**
The port blank provides EMI shielding and helps maintain proper thermal status inside the server. Do not operate the server when a port blank is removed without the corresponding I/O port option installed.

Procedure

1. Power down the server.
2. Remove all power:
 - a. Disconnect each power cord from the power source.
 - b. Disconnect each power cord from the server.
3. Disconnect all peripheral cables from the server.
4. Do one of the following:
 - If the server is in tower mode, place the server on a flat, level surface with the access panel facing up.
 - If the server is in rack mode, remove the server from the rack.
5. Unlock the front bezel.
6. Remove the access panel.
7. If installing an OCP adapter in Slot 14, remove the primary riser cage.
8. If installing an OCP adapter in Slot 15, and the secondary riser cage is installed, remove the secondary riser cage.
9. Remove the OCP slot blank:
 - a. Remove the blank screw.
 - b. Use a plastic spudger to pry the top side of the blank from the chassis.
 - c. Remove the blank.

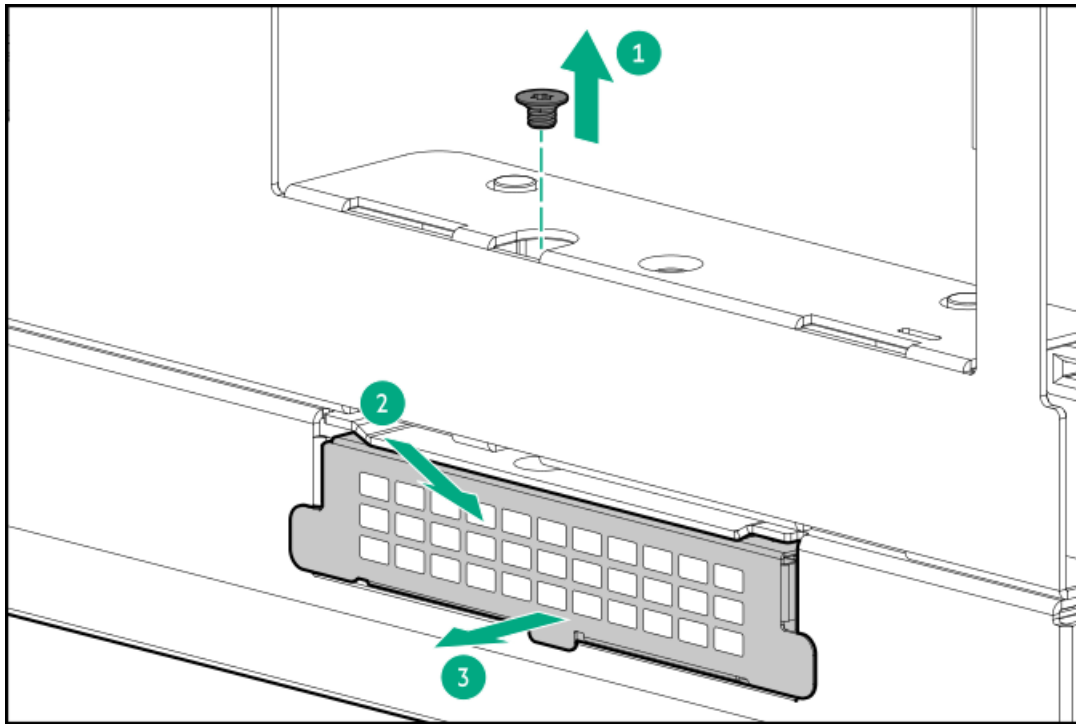

10. Install the OCP NIC 3.0 adapter:

- a. Rotate the locking pin to the open (vertical) position.
- b. Slide the adapter into the bay until it clicks into place.
Make sure that the adapter is seated firmly in the slot.
- c. Rotate the locking pin to the close (horizontal) position.

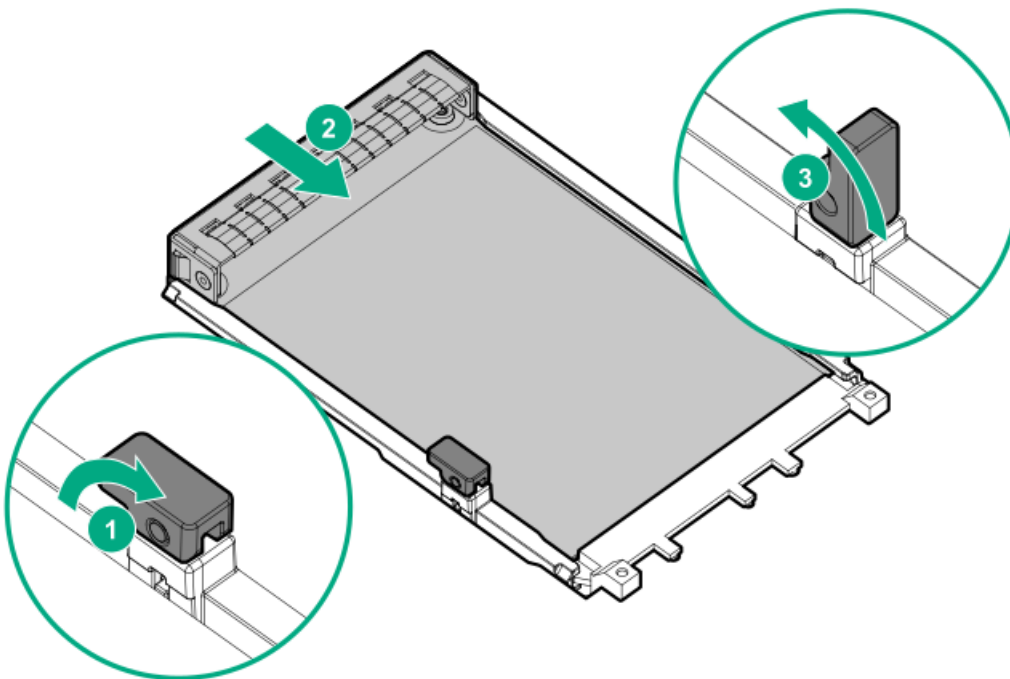

11. If you are installing an OCP NIC 3.0 x16 adapter, connect the OCP bandwidth upgrade cable.
12. If removed, install the riser cage.
13. Install the access panel.
14. Do one of the following:



- Orient the server back in tower mode.
 - Install the server into the rack.
15. Connect all peripheral cables to the server.
 16. Connect each power cord to the server.
 17. Connect each power cord to the power source.
 18. Power up the server.

Results

The installation is complete.

Chassis intrusion detection switch option

The chassis intrusion detection switch enables iLO to record an event in the Integrated Management Log (IML) whenever the access panel is physically opened or removed. An alert is also sent to the BIOS whenever a chassis intrusion is detected. The chassis intrusion detection occurs as long as the server is plugged in, regardless of whether the server is powered on or off.

Subtopics

Installing the chassis intrusion detection switch

Installing the chassis intrusion detection switch

Procedure

1. Power down the server.
2. Remove all power:
 - a. Disconnect each power cord from the power source.
 - b. Disconnect each power cord from the server.
3. Disconnect all peripheral cables from the server.
4. Do one of the following:
 - If the server is in tower mode, place the server on a flat, level surface with the access panel facing up.
 - If the server is in rack mode, remove the server from the rack.
5. Unlock the front bezel.
6. Remove the access panel.
7. Install the chassis intrusion detection switch:
 - a. Insert the switch tab into the chassis slot until the switch clicks into place.
 - b. Connect the switch cable and secure it in the cable clamp.

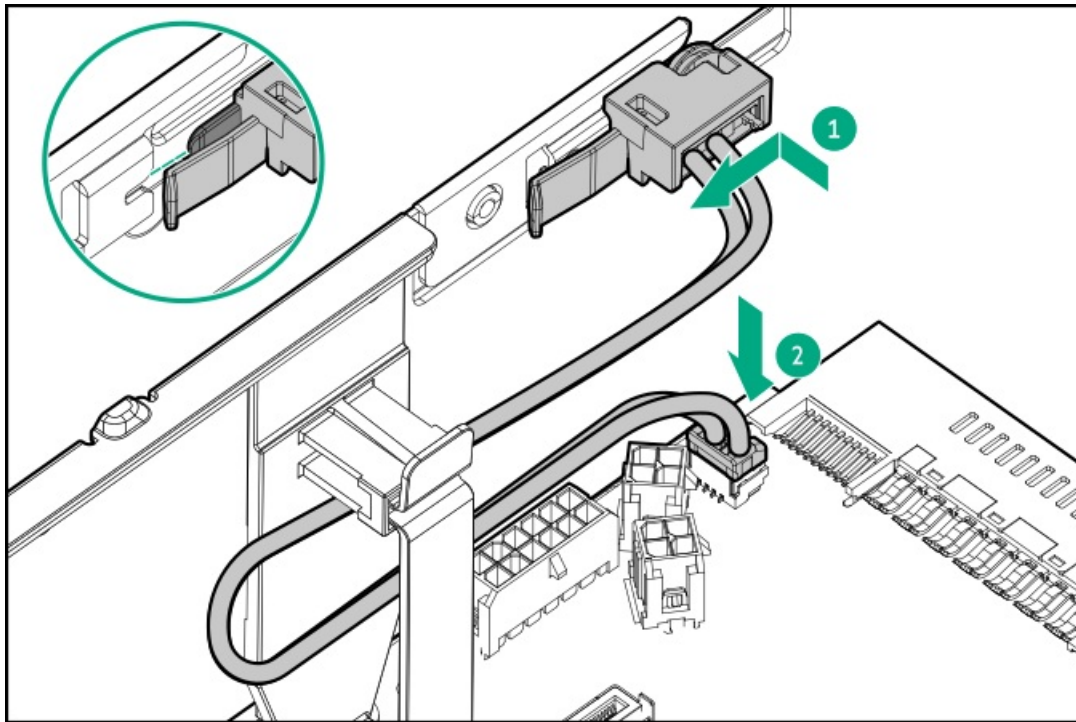

8. Install the access panel.
9. Lock the front bezel.
10. Do one of the following:
 - Orient the server back in tower mode.
 - Install the server into the rack.
11. Connect all peripheral cables to the server.
12. Connect each power cord to the server.
13. Connect each power cord to the power source.
14. Power up the server.

Results

The installation is complete.

Serial port option

Install the serial port option to enable communication to physical serial devices. You can also use the serial connection to remotely access the system BIOS and view POST error messages.

Subtopics

Installing the serial port

Installing the serial port

Prerequisites



Before you perform this procedure, make sure that you have a hex screwdriver available.

About this task

CAUTION: A discharge of static electricity from a finger or other conductor might damage system boards or other static-sensitive devices. To prevent damage, observe [antistatic precautions](#).

CAUTION:
The port blank provides EMI shielding and helps maintain proper thermal status inside the server. Do not operate the server when a port blank is removed without the corresponding I/O port option installed.

Procedure

1. [Power down the server](#).
2. Remove all power:
 - a. Disconnect each power cord from the power source.
 - b. Disconnect each power cord from the server.
3. Disconnect all peripheral cables from the server.
4. Do one of the following:
 - If the server is in tower mode, [place the server on a flat, level surface with the access panel facing up](#).
 - If the server is in rack mode, [remove the server from the rack](#).
5. Unlock the front bezel.
6. [Remove the access panel](#).
7. [Remove the secondary riser cage](#).
8. Remove the serial port blank.

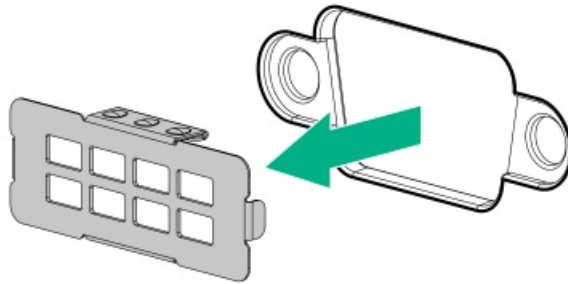

9. Install the serial port cable:
 - a. Insert the serial port into the rear panel opening.
 - b. Install the hex screws.

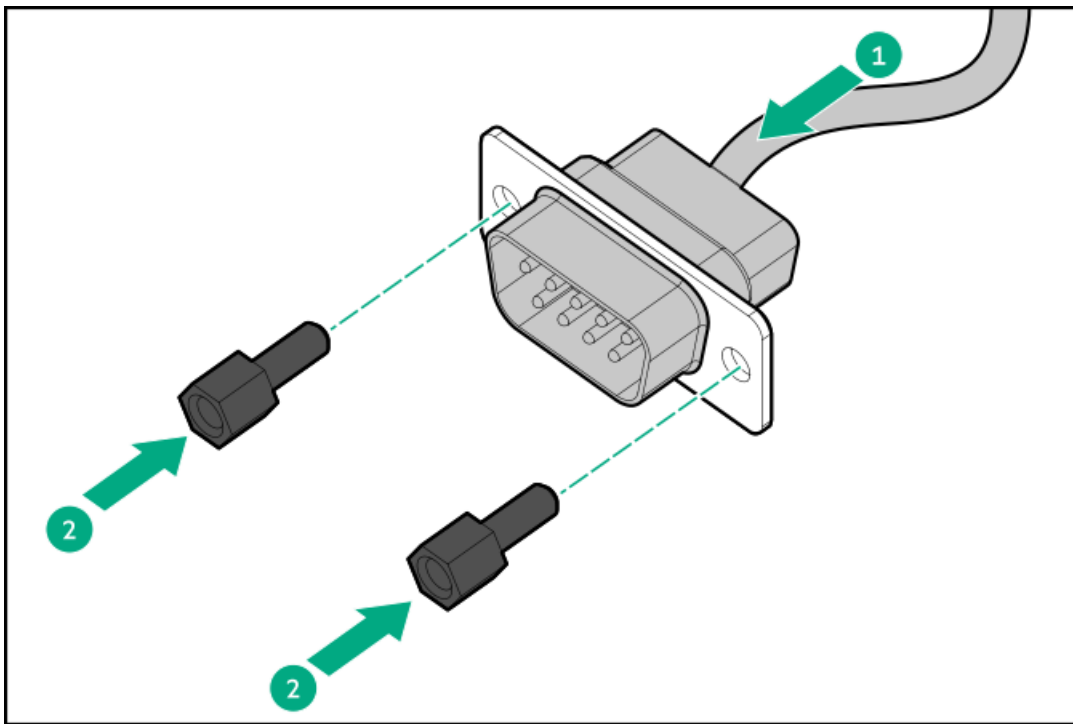

10. Connect the serial port cable to the system board.

11. Install the secondary riser cage.

12. Install the access panel.

13. Lock the front bezel.

14. Do one of the following:

- Orient the server back in tower mode.
- Install the server into the rack.

15. Connect all peripheral cables to the server.

16. Connect each power cord to the server.

17. Connect each power cord to the power source.

18. Power up the server.

Configuring the serial port

19. To configure the serial port setting:

- a. From the boot screen, press **F9** to access the UEFI System Utilities.
- b. From the System Utilities screen, select System Configuration > BIOS/Platform Configuration (RBSU) > System Options > Serial Port Options > Embedded Serial Port.
- c. Select a setting.
- d. Press **F12** key to save your selection.
- e. Click Yes-Save Changes.
- f. Click Reboot.

Results

The installation is complete.



Internal USB device options

The server has one internal USB 2.0 port and one USB 3.2 Gen 1 port . Use these ports to install internal USB devices such as:

- USB flash media devices for booting up from flash solutions or for data backup/redundancy.
- USB RDX drives for an inexpensive and reliable way to securely store your data backups.

For RDX drive installation, see [Installing a USB RDX docking station](#).

Subtopics

[Installing an internal USB device](#)

Installing an internal USB device

Procedure

1. [Power down the server](#).
2. Remove all power:
 - a. Disconnect each power cord from the power source.
 - b. Disconnect each power cord from the server.
3. Disconnect all peripheral cables from the server.
4. Do one of the following:
 - If the server is in tower mode, [place the server on a flat, level surface with the access panel facing up](#).
 - If the server is in rack mode, [remove the server from the rack](#).
5. Unlock the front bezel.
6. [Remove the access panel](#).
7. Plug in the USB device into the USB port.

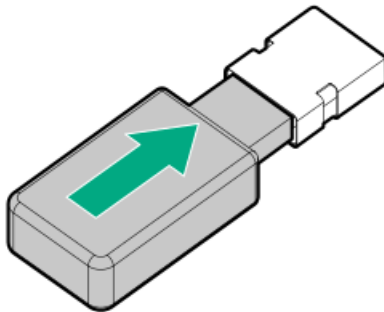

8. [Install the access panel](#).
9. Lock the front bezel.
10. Do one of the following:
 - [Orient the server back in tower mode](#).
 - [Install the server into the rack](#).
11. Connect all peripheral cables to the server.

12. Connect each power cord to the server.
13. Connect each power cord to the power source.
14. Power up the server.

Results

The installation is complete.

Cabling

This chapter includes cabling guidelines and diagrams for internal component cabling.

Subtopics

Cabling guidelines

Cabling diagrams

Internal cabling management

Storage cabling

Media device cabling

GPU auxiliary power cabling

Fan cabling

HPE NS204i-u Boot Device cabling

OCP upgrade cabling

Tertiary riser signal cabling

Serial port cabling

Chassis intrusion detection switch cabling

Front I/O cabling

Cabling guidelines

Observe the following:

- For cable option kits, see the product QuickSpecs.
- For cable spare part numbers, see the Illustrated parts catalog in the maintenance and service guide.
- Some diagrams show alphabetical callouts such as A, B, C, etc. These callouts correspond to labels near the connectors on the cable.
- Some cables have more than one connector, such as a Y-cable, but not all connectors are used.
- The cable colors in the cabling diagrams used in this chapter are for illustration purposes only.
- Observe all guidelines when working with server cables.

Before connecting cables

- Note the port labels on the PCA components. Not all these components are used by all servers:



- System board ports
- Drive and power supply backplane ports
- Expansion board ports (controllers, retimers, adapters, expanders, risers, and similar boards)
- Note the label near each cable connector. This label indicates the destination port for the cable connector.
- Some data cables are prebent. Do not unbend or manipulate the cables.
- To prevent mechanical damage or depositing oil that is present on your hands, and other contamination, do not touch the ends of the connectors.

When connecting cables

- Before connecting a cable to a port, lay the cable in place to verify the length of the cable.
- Use the internal cable management features to properly route and secure the cables.
- When routing cables, be sure that the cables are not in a position where they can be pinched or crimped.
- Avoid tight bend radii to prevent damaging the internal wires of a power cord or a server cable. Never bend power cords and server cables tight enough to cause a crease in the sheathing.
- Make sure that the excess length of cables is properly secured to avoid excess bends, interference issues, and airflow restriction.
- To prevent component damage and potential signal interference, make sure that all cables are in their appropriate routing position before installing a new component and before closing up the server after hardware installation/maintenance.

When disconnecting cables

- Grip the body of the cable connector. Do not pull on the cable itself because this action can damage the internal wires of the cable or the pins on the port.
- If a cable does not disconnect easily, check for any release latch that must be pressed to disconnect the cable.



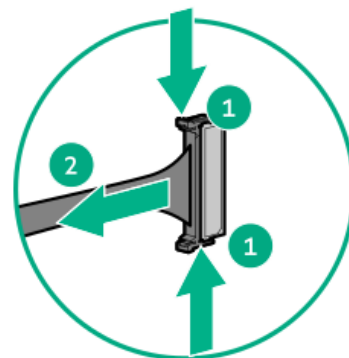
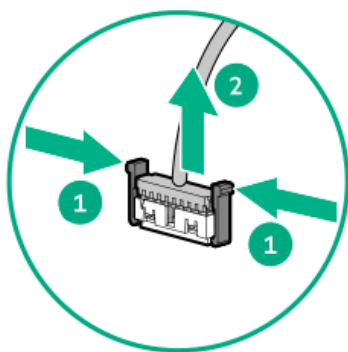
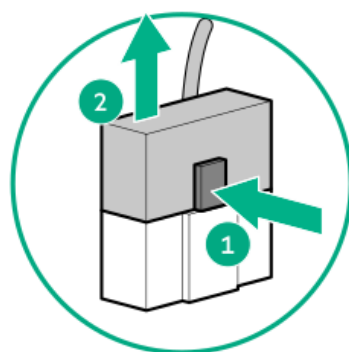
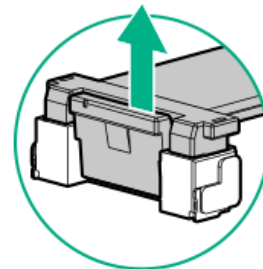
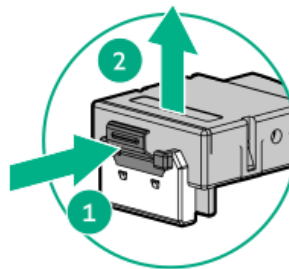
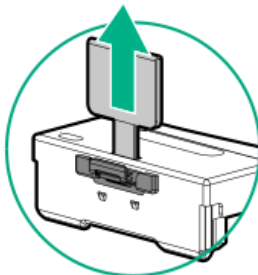
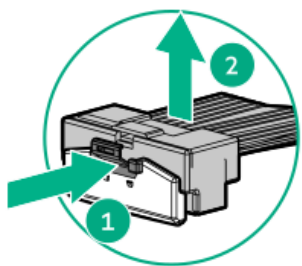
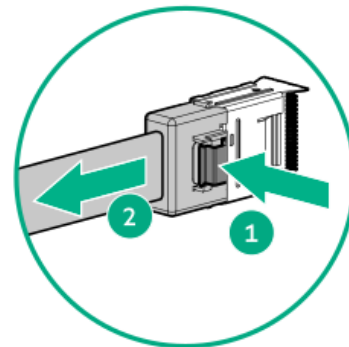
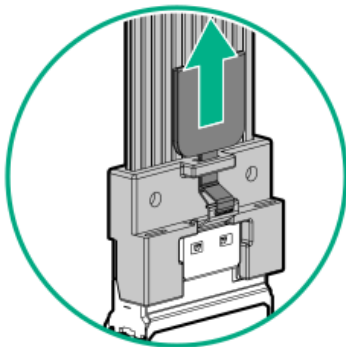
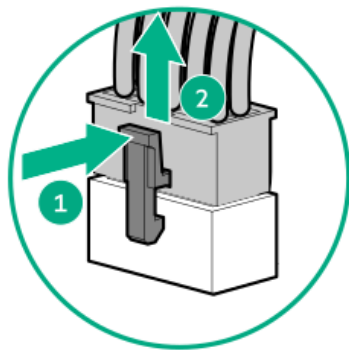

- Remove cables that are no longer being used. Retaining them inside the server can restrict airflow. If you intend to use the removed cables later, label and store them for future use.

Cabling diagrams

Observe the following:

Component cabling	Cable part number
Storage cabling	—
4/8/12 LFF drive onboard SATA cable	P45298-001 P45299-001
8 SFF drive onboard SATA cable	P45293-001



Component cabling	Cable part number
8 SFF drive onboard NVMe cable	<u>P45294-001</u>
12 E3.S drive onboard NVMe cable	<u>P50268-001</u>
	<u>P49078-001</u>
	<u>P49004-001</u>
4/8/12 LFF SAS/SATA drive controller cable: type-o controller in Slot 14	<u>P45306-001</u>
	<u>P49936-001</u>
4/8/12 LFF SAS/SATA drive controller cable: type-p controller in the primary riser	<u>P45301-001</u>
	<u>P45300-001</u>
8/16 SFF SAS/ NVMe x1 drive controller cable: type-o controller in Slot 14	<u>P45304-001</u>
8 SFF SAS/ NVMe x1 drive controller cable: type-p controller in the primary riser	<u>P45297-001</u>
16 SFF SAS/ NVMe x1 drive controller cable: type-p controller in the primary riser	<u>P45296-001</u>
	<u>P45297-001</u>
8 SFF NVMe x4 drive controller cable	<u>P45297-001</u>
4 LFF + 8 SFF / 4 LFF + 16 SFF drive controller cable	<u>P45296-001</u>
	<u>P45306-001</u>
Drive power cabling	—
LFF/SFF drive power cable	<u>869825-001</u>
E3.S drive power cable	<u>P49005-001</u>
Energy pack cabling	—
Energy pack extension cable	<u>873905-001</u>
Storage controller backup power cable	<u>877850-001</u>
Media device cabling	—
USB RDX docking station cable	<u>P45303-001</u>
	<u>876507-002</u>
Optical drive cable	<u>756914-001</u>
HPE NS204i-u Boot Device cabling	<u>P54092-001</u>
	<u>P54089-001</u>
GPU auxiliary power cabling	—
GPU auxiliary power Y-cable	<u>P58422-001</u>
GPU auxiliary power straight cable	<u>869820-001</u>
External fan cabling	<u>P45291-001</u>
OCP upgrade cabling	—
OCP bandwidth upgrade cable	<u>P43734-001</u>
	<u>P43736-001</u>
Dual OCP slot upgrade cable for single-processor server	<u>P56686-001</u>
Tertiary riser signal cabling	<u>P52240-001</u>
Miscellaneous cabling	—
Serial port cable	<u>P45623-001</u>

Component cabling

Cable part number

Chassis intrusion detection switch cable

P47751-001

Front I/O cable

P45292-001

Internal cabling management

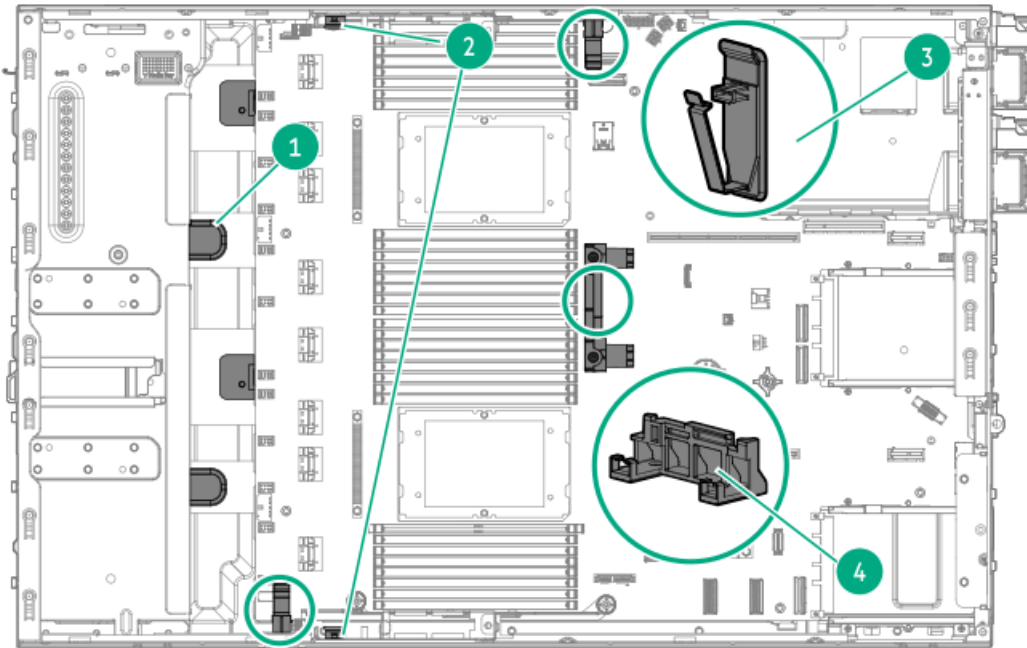

Item	Description
1	Metal tabs
2	Tabs on the fan cage brackets
3	Cable clamps
4	System board handle

Storage cabling

Subtopics

Storage controller cabling

Drive power cabling

Energy pack cabling

Storage controller backup power cabling

Storage controller cabling

4/8/12 LFF drive: Onboard SATA cabling

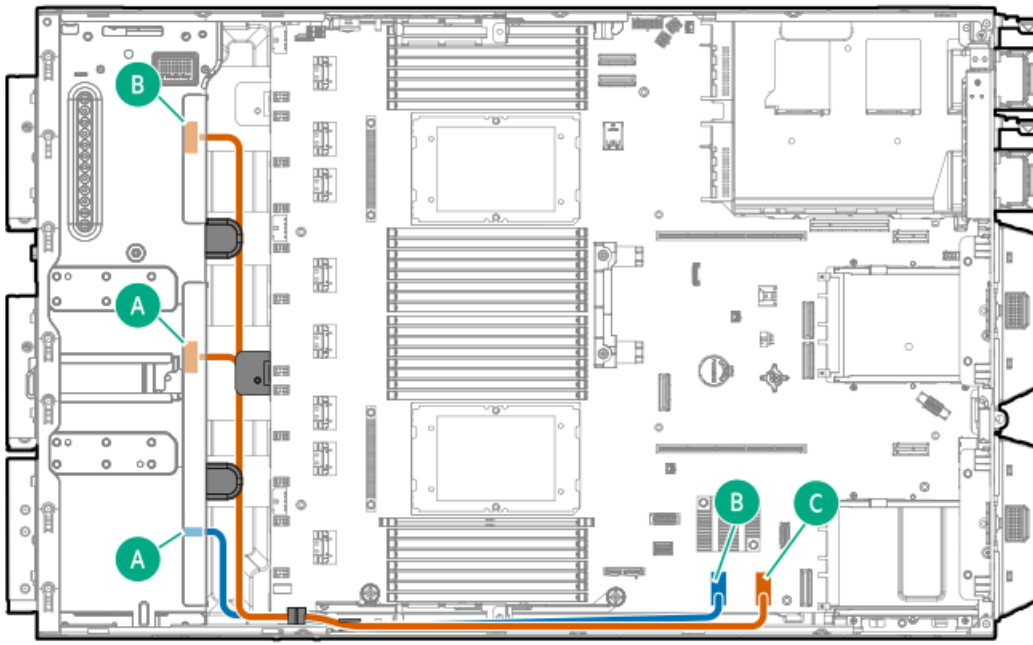

Cable part number	Color	From	To
P45298-001 ¹	Orange	Box 1 port 1 and Box 2 port 1	PCH LP SlimSAS port 2
P45299-001 ¹	Blue	Box 3 port 1	PCH LP SlimSAS port 1

¹ Option kit: P47225-B21

8 SFF drive: Onboard SATA cabling

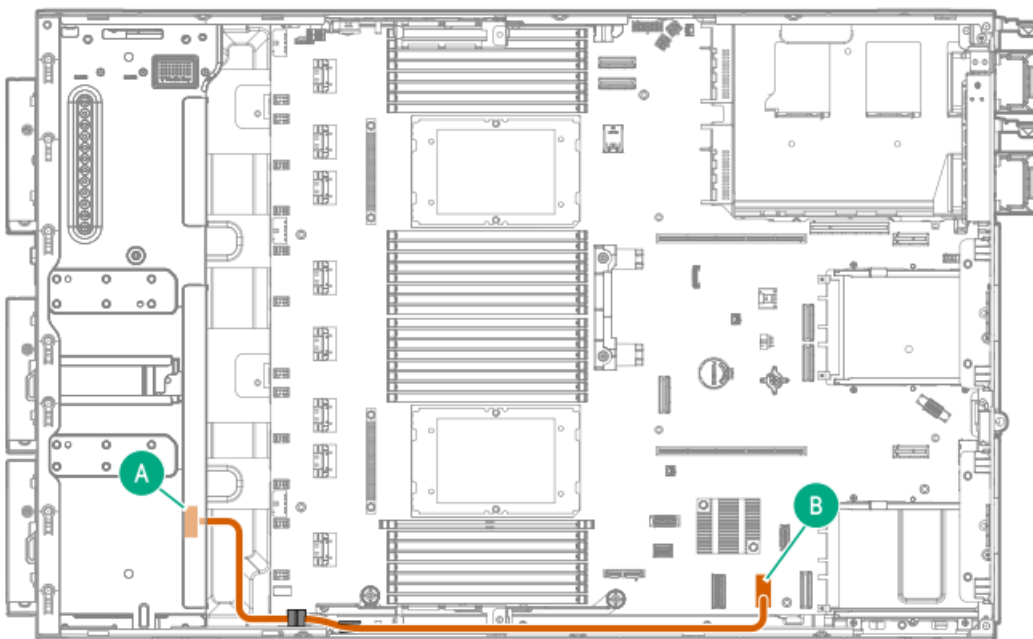

Cable part number	Color	From	To
P45293-001 ¹	Orange	Box 3 port 1	PCH LP SlimSAS port 2

¹ Option kit: P47232-B21

8 SFF drive: Onboard NVMe cabling

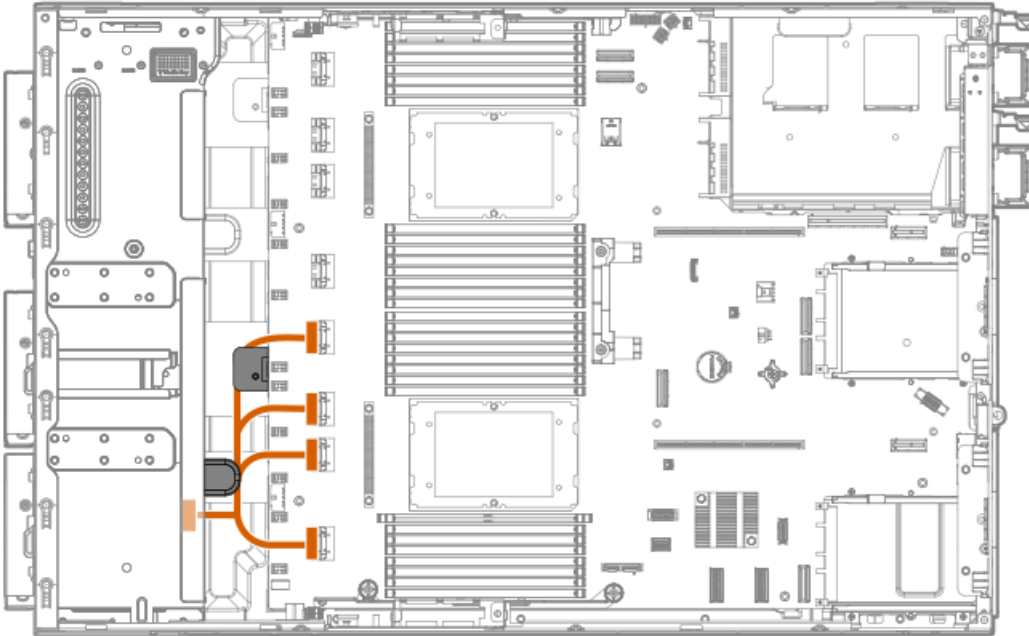

Cable part number	Color	From	To
P45294-001 ¹	Orange	Box 3 ports 1-4	x8 SlimSAS ports 1A-4A

¹ Option kit: P48399-B21

12 E3.S drive: Onboard NVMe cabling



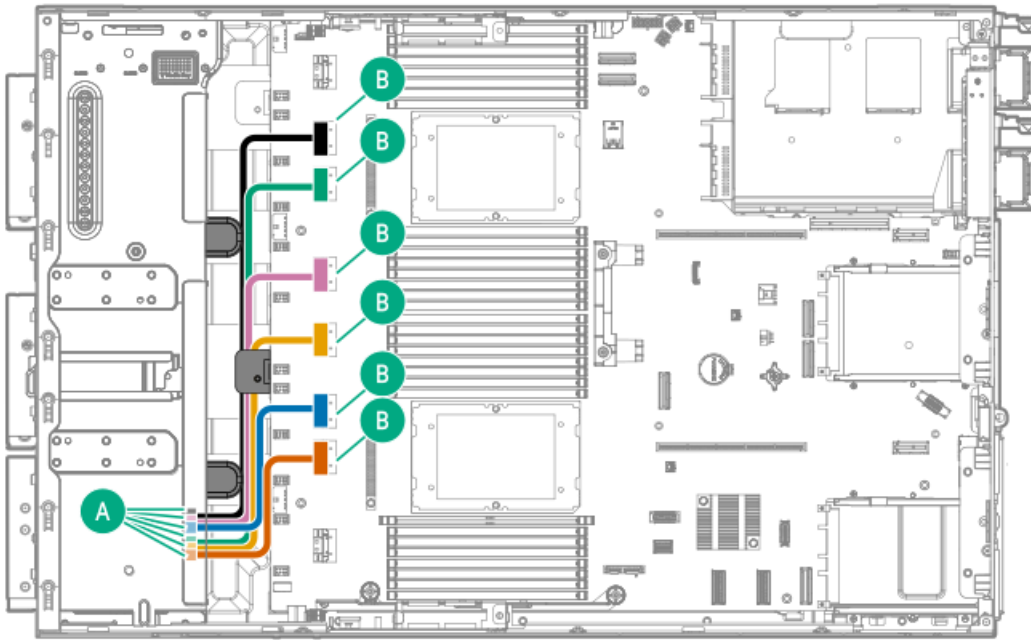

Cable part number	Color	From	To
P50268-001 ¹	Orange	Box 3 port 1	x8 SlimSAS port 3A
	Blue	Box 3 port 2	x8 SlimSAS port 2A
P49078-001 ¹	Gold	Box 3 port 3	x8 SlimSAS port 1A
	Pink	Box 3 port 4	x8 SlimSAS port 4B
P49004-001 ¹	Green	Box 3 port 5	x8 SlimSAS port 3B
	Black	Box 3 port 6	x8 SlimSAS port 2B

¹ Option kit: P48400-B21

4/8/12 LFF SAS/SATA drive controller cabling: Type-o controller in Slot 14

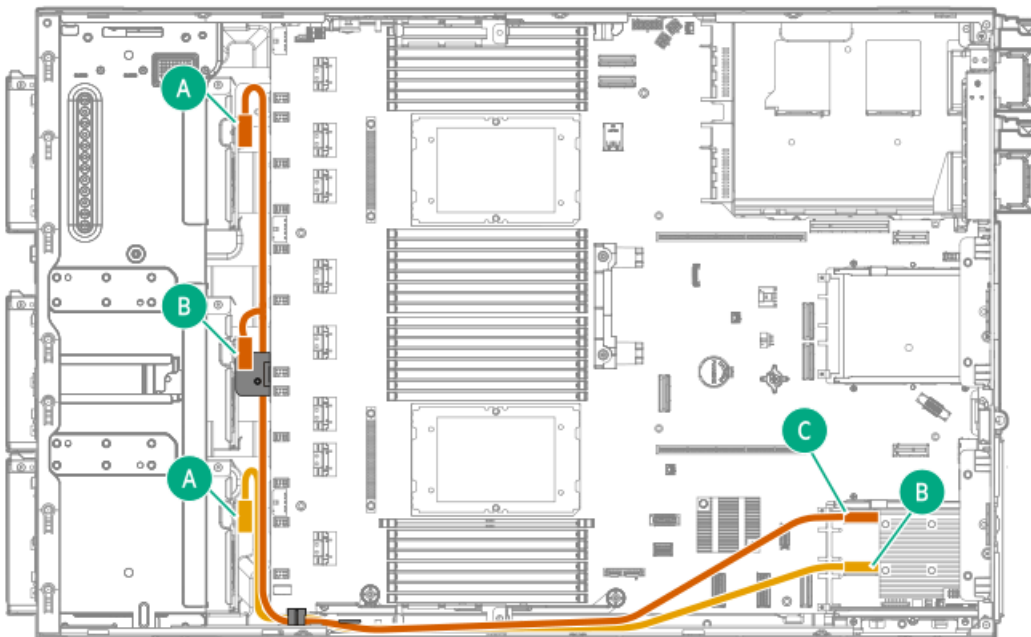

Cable part number	Color	From	To
P45306-001 ¹	Orange	Box 1 port 1 and Box 2 port 1	Type-o storage controller port 2
P49936-001 ¹	Gold	Box 3 port 1	Type-o storage controller port 1

¹ Option kit: P47229-B21

4/8/12 LFF SAS/SATA drive controller cabling: Type-p controller in the primary riser

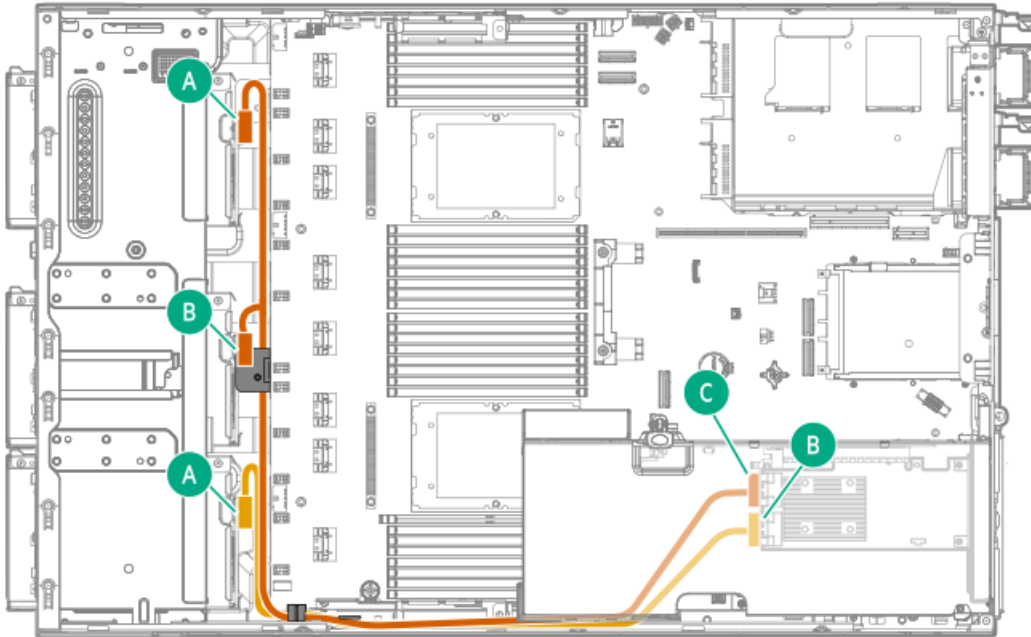

Cable part number	Color	From	To
P45301-001 ¹	Orange	Box 1 port 1 and Box 2 port 1	Primary type-p storage controller port 2
P45300-001 ¹	Gold	Box 3 port 1	Primary type-p storage controller port 1

¹ Option kit: P47227-B21

8/16 SFF SAS/ NVMe x1 drive controller cabling: Type-o controller in Slot 14



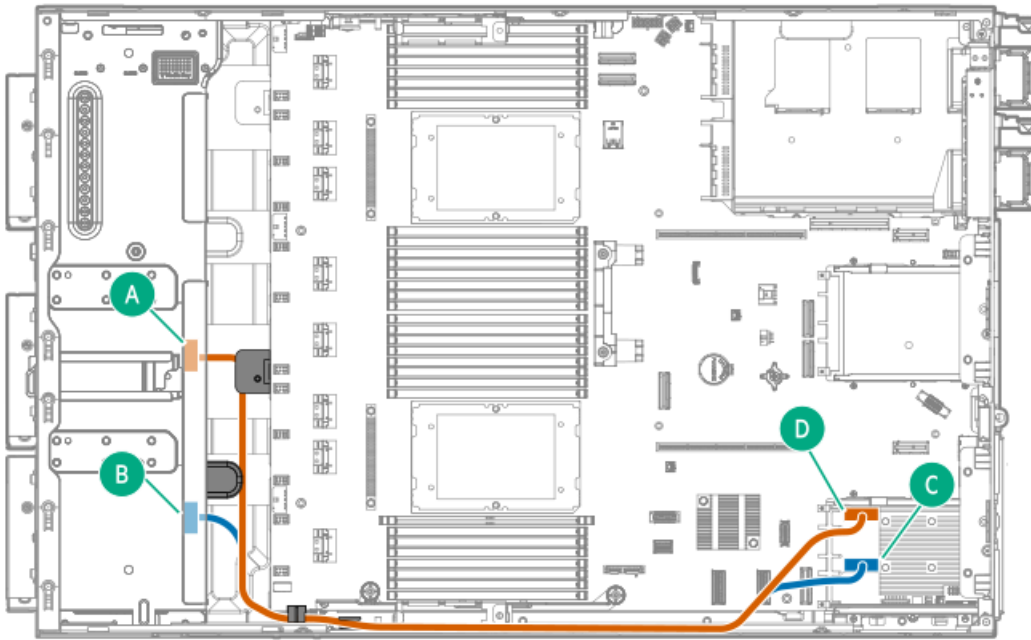

Cable part number	Color	From	To
P45304-001 ¹	Orange	Box 2 port 1	Type-o storage controller port 2
	Blue	Box 3 port 1	Type-o storage controller port 1

¹ Option kit: P47235-B21

8 SFF SAS/ NVMe x1 drive controller cabling: Type-p controller in the primary riser

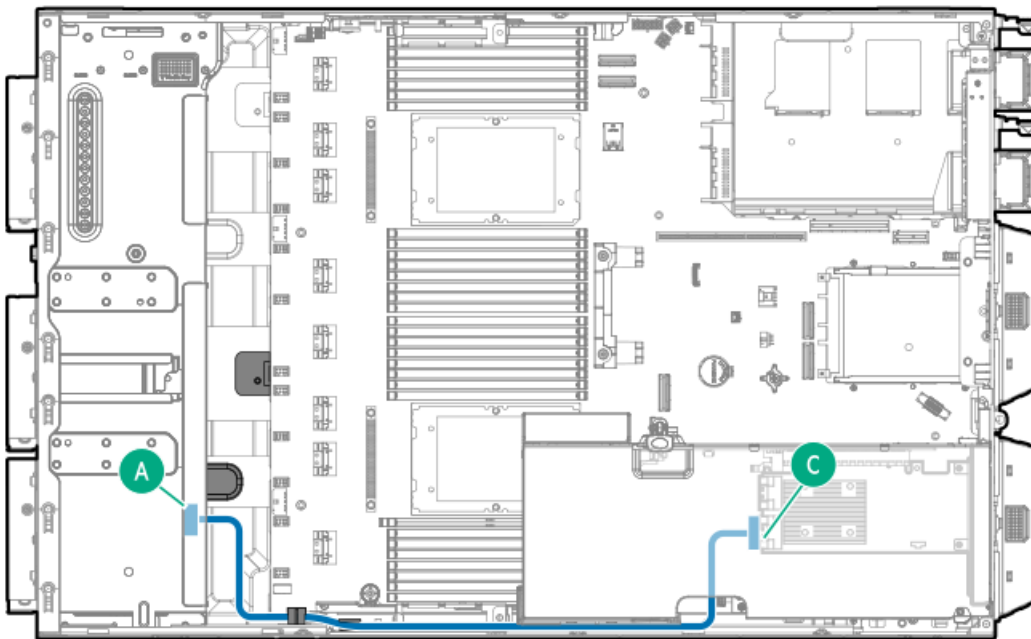

Cable part number	Color	From	To
P45297-001 ¹	Blue	Box 3 port 1	Primary type-p storage controller port 1



1 Option kit: P47233-B21

16 SFF SAS/ NVMe x1 drive controller cabling: Type-p controller in the primary riser

- Box 2 and Box 3

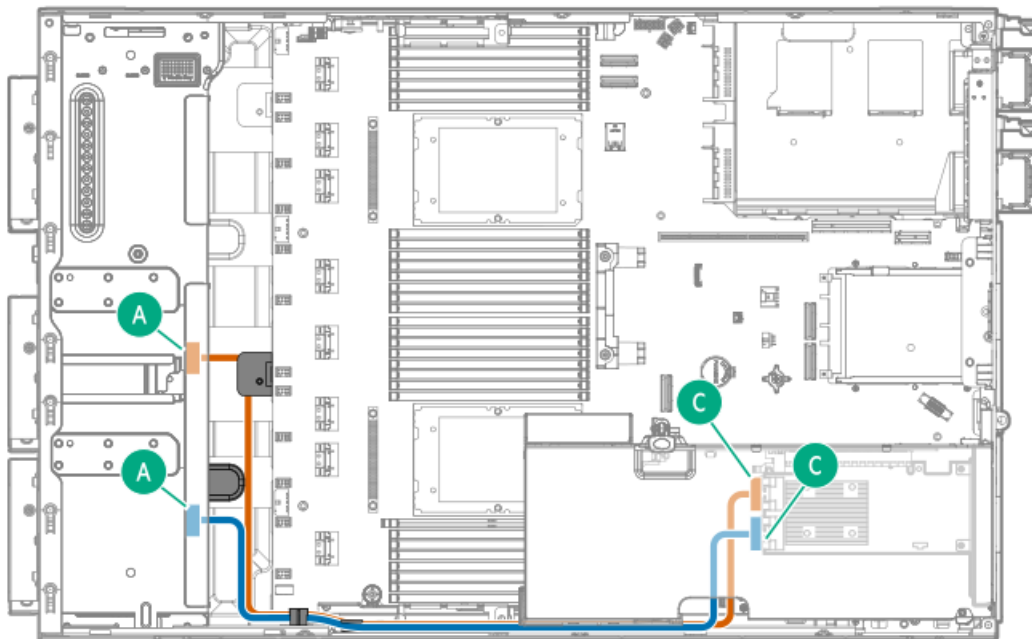

Cable part number	Color	From	To
P45296-001 ¹	Orange	Box 2 port 1	Primary type-p storage controller port 2
P45297-001 ¹	Blue	Box 3 port 1	Primary type-p storage controller port 1

1 Option kit: P47233-B21

- Box 1 and Box 2



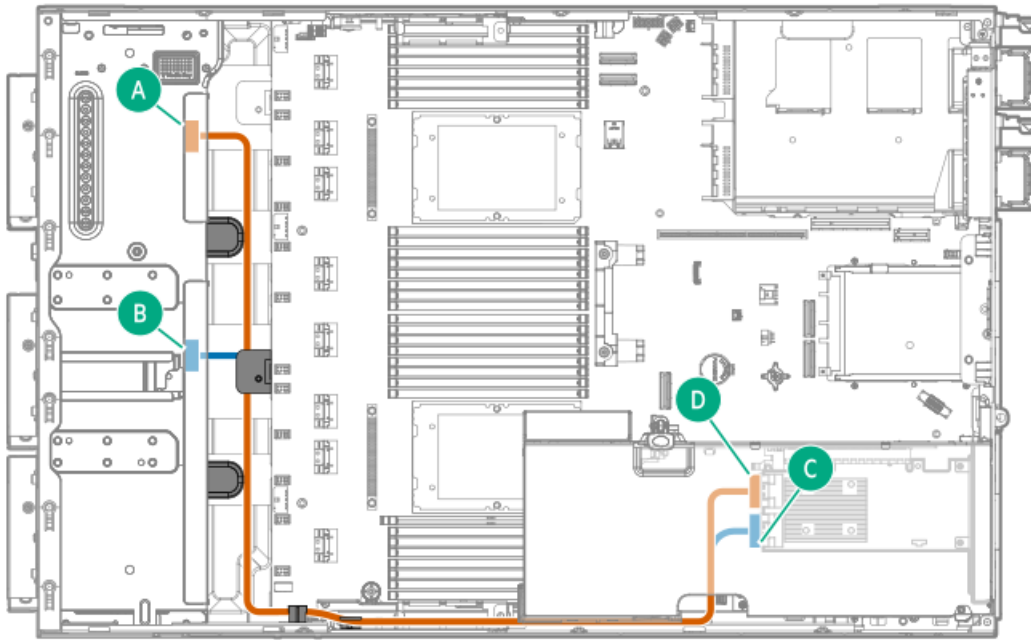

Cable part number	Color	From	To
P45296-001 ¹	Orange	Box 1 port 1	Primary type-p storage controller port 2
	Blue	Box 2 port 1	Primary type-p storage controller port 1

¹ Option kit: P47233-B21

8 SFF NVMe x4 drive controller cabling

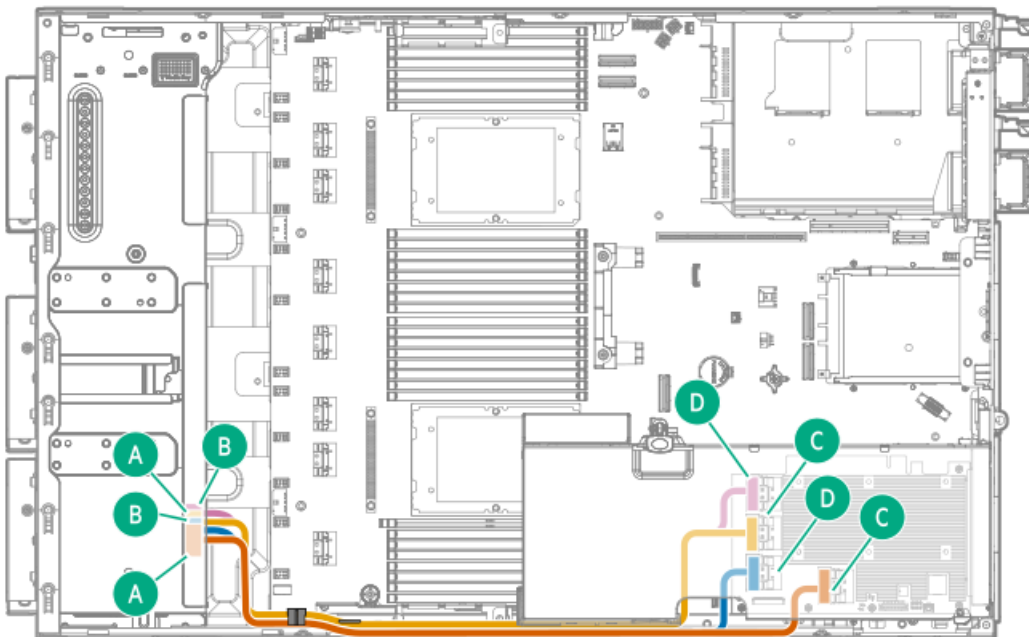

Cable part number	Color	From	To
P45297-001 ¹ ²	Orange	Box 3 port 1	Primary type-p storage controller port 1
	Blue	Box 3 port 2	Primary type-p storage controller port 2
	Gold	Box 3 port 3	Primary type-p storage controller port 3
	Pink	Box 3 port 4	Primary type-p storage controller port 4

¹ Option kit: P47234-B21
This is a splitter cable. Ports 1-2 use one cable; Ports 3-4 use one cable.

² 4 LFF + 8 SFF / 4 LFF + 16 SFF drive controller cabling

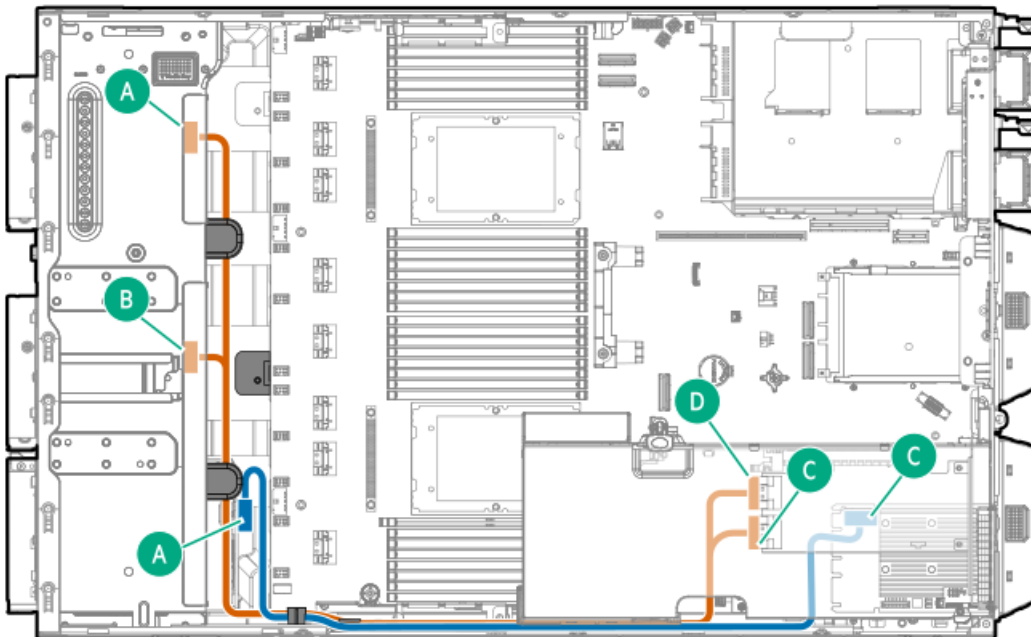

Cable part number	Color	From	To
P45296-001 ¹	Orange	Box 1 port 1 and Box 2 port 1	Primary type-p storage controller ports 1-2
P45306-001 ²	Blue	Box 3 port 1	Type-o storage controller port 1

¹ Option kit: P47233-B21
² Option kit: P47229-B21

Drive power cabling

Drive power cables are either preinstalled in the server or structured under the relevant storage controller cable option kit.

LFF/SFF drive power cabling

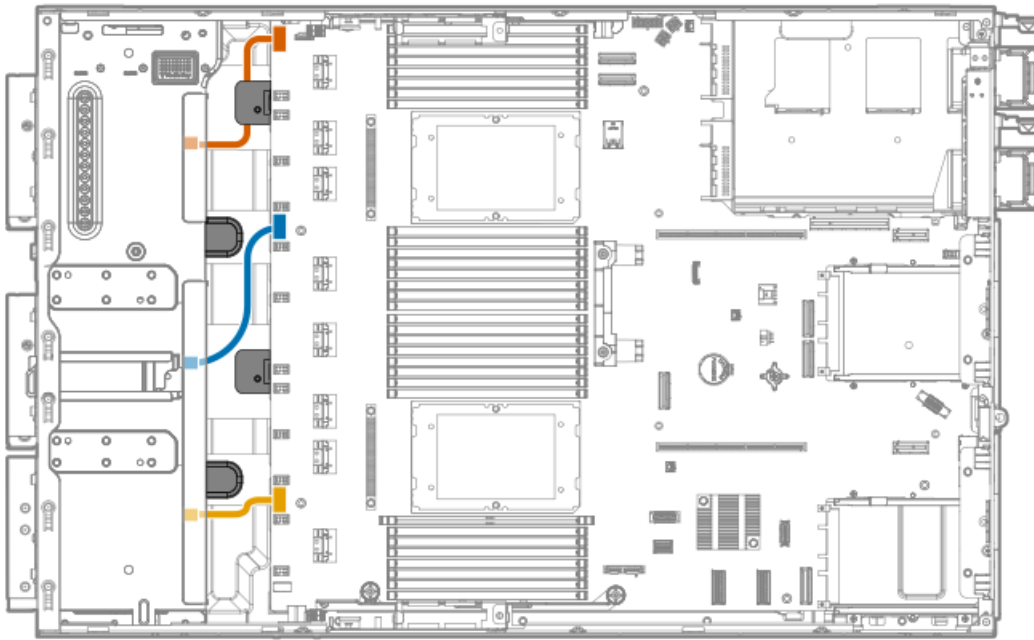

Cable part number	Color	From	To
869825-001	Orange	Box 1 power connector	Drive box 1 power connector
	Blue	Box 2 power connector	Drive box 2 power connector
	Gold	Box 3 power connector	Drive box 3 power connector

E3.S drive power cabling

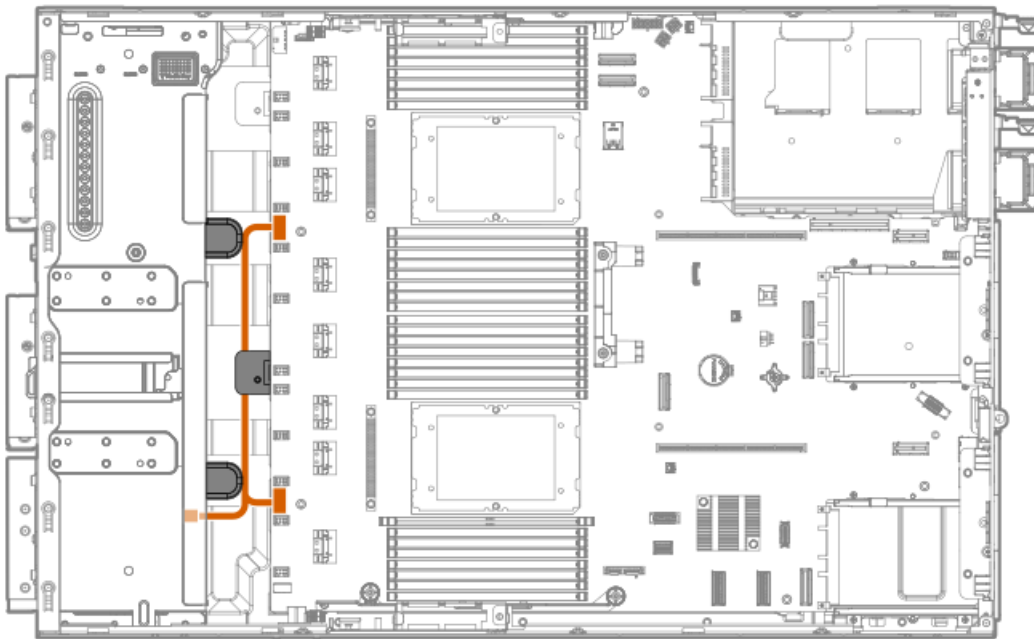

Cable part number	Color	From	To
P49005-001	Orange	Box 3 power connector	<ul style="list-style-type: none"> • Drive box 3 power connector • Drive box 2 power connector

Energy pack cabling

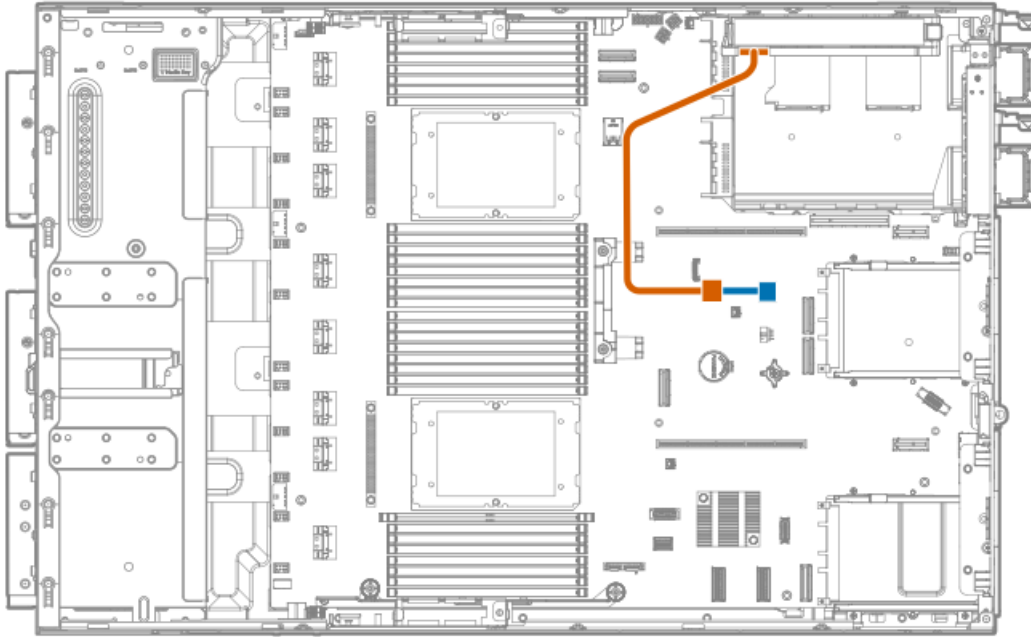

Cable part number	Color	From	To
873905-001 ¹	Blue	Energy pack cable	Energy pack connector

¹ Option kit: P58199-B21

Storage controller backup power cabling

The exact route of the storage controller backup power cabling will depend on:

- The riser slot where the controller is installed
- The location of the storage controller backup power connector on the controller

Use the following diagrams for reference only.

Storage controller backup power cabling from type-o storage controller in Slot 14



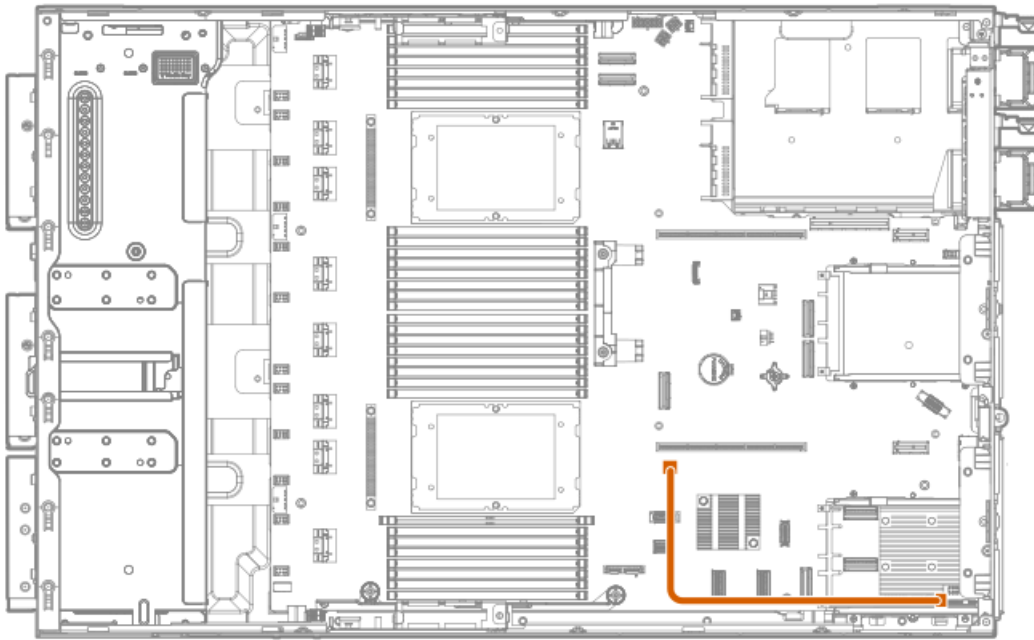

Color	From	To
Orange	Type-o controller	Slot 14 OCP storage backup power connector

Storage controller backup power cabling from type-p storage controller in the primary riser

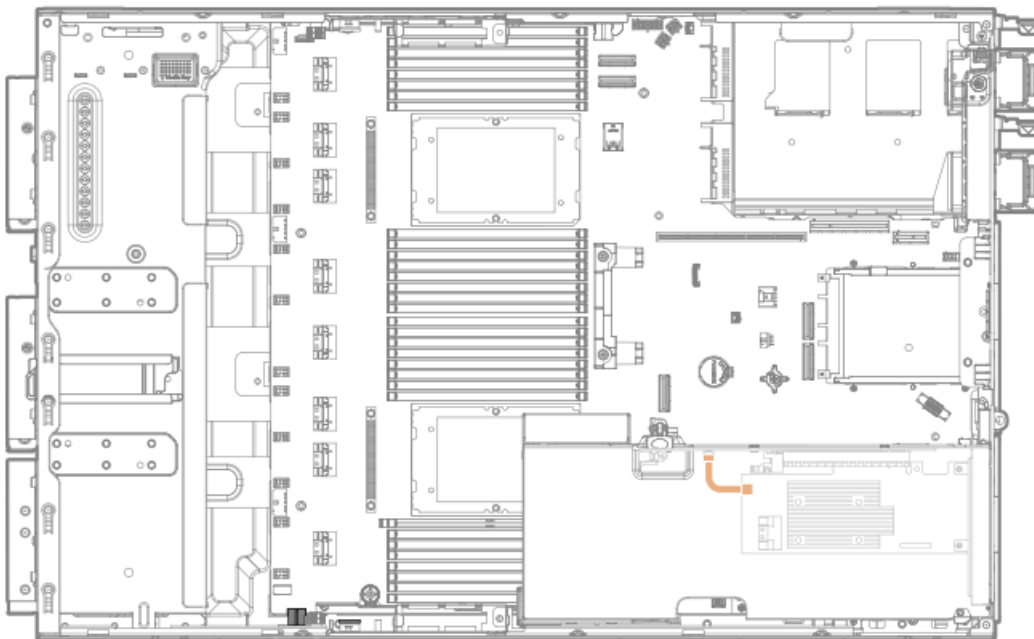

Color	From	To
Orange	Type-p controller	Storage controller backup power connector

Media device cabling



Subtopics

[USB RDX docking station cabling](#)

[Optical drive cabling](#)

USB RDX docking station cabling

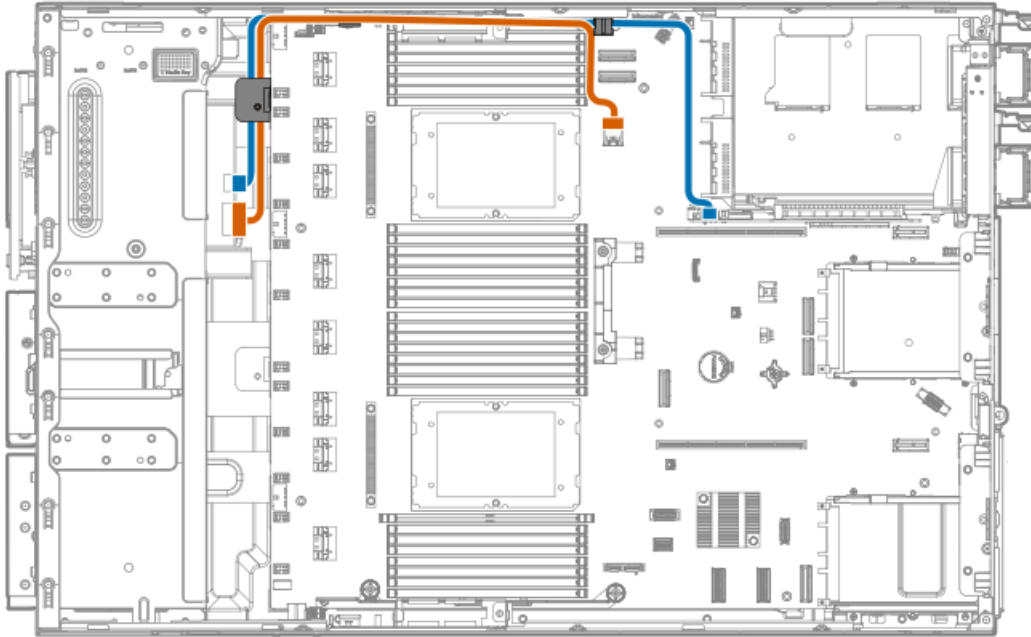

Cable part number	Color	From	To
P45303-001 ¹	Blue	RDX power connector	RDX power connector on the tertiary riser
876507-002 ¹	Orange	RDX USB port	USB 3.2 Gen 1 port

¹ Option kit: P49694-B21

Optical drive cabling



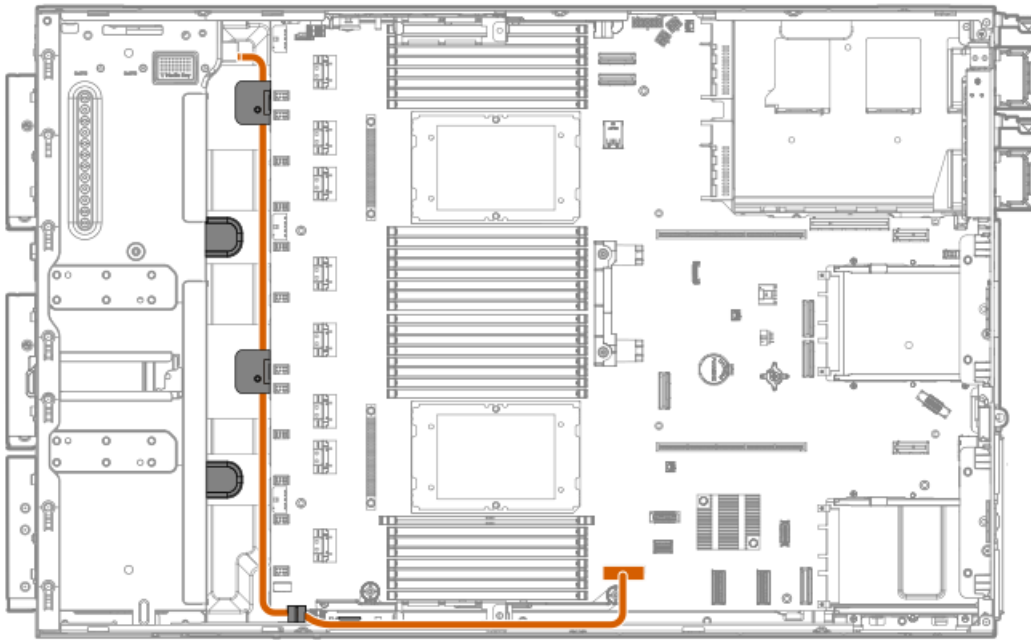

Cable part number	Color	From	To
756914-001 ¹	Orange	Optical drive	Optical drive SATA-power connector

¹ This cable ships with the optical drive option.

GPU auxiliary power cabling

The exact route of the GPU auxiliary power cabling will depend on the:

- The riser cage where the accelerator is installed.
- The location of the power connector on the accelerator.

Use the following diagrams for reference only.

GPU auxiliary power Y-cable



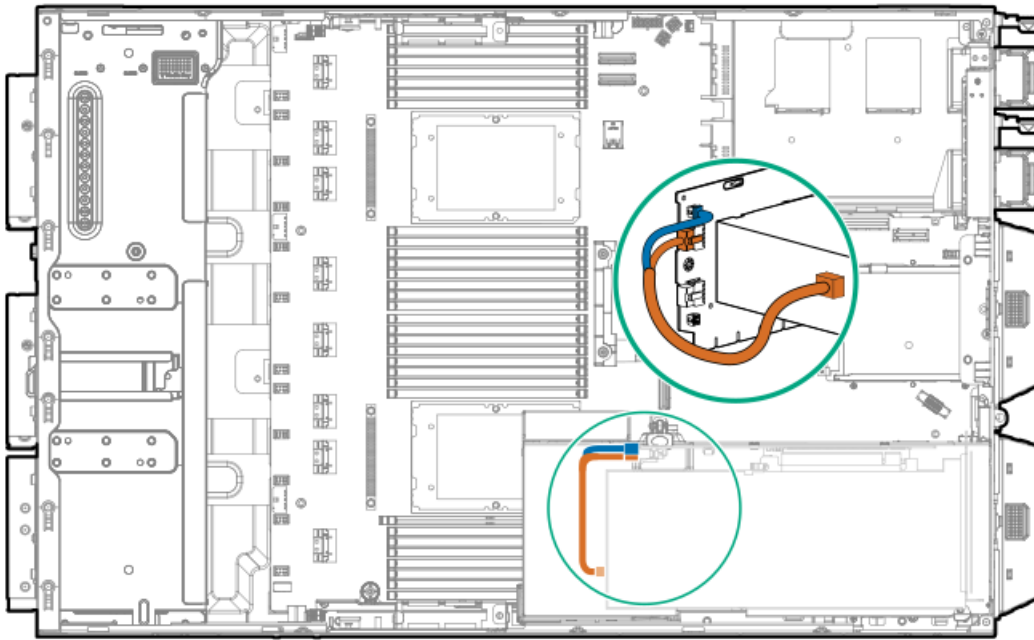

Cable part number	Color	From	To
P58422-001 ¹	Orange	Accelerator power connector	<u>GPU auxiliary power connector on the PCIe 2 x16 riser</u>
	Blue		<u>GPU sideband connector on the PCIe 2 x16 riser</u>

¹ Option kit: P47221-B21

GPU auxiliary power straight cable

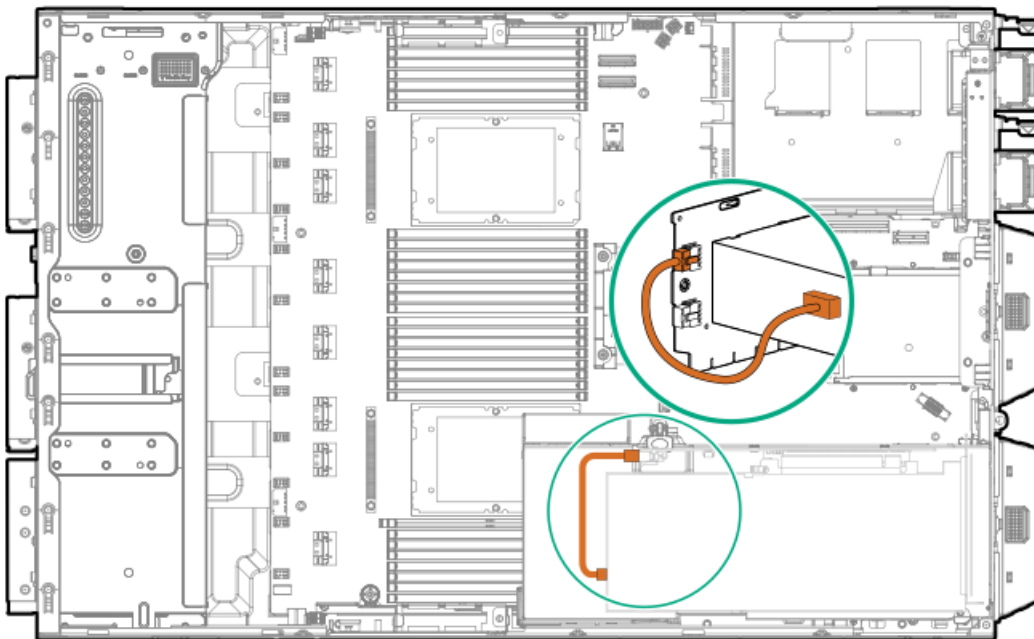

Cable part number	Color	From	To
869820-001 ¹	Orange	Accelerator power connector	<u>GPU auxiliary power connector on the PCIe5 2 x16 riser</u>

¹ Option kit: P39102-B21

Fan cabling

Internal fans 1–8

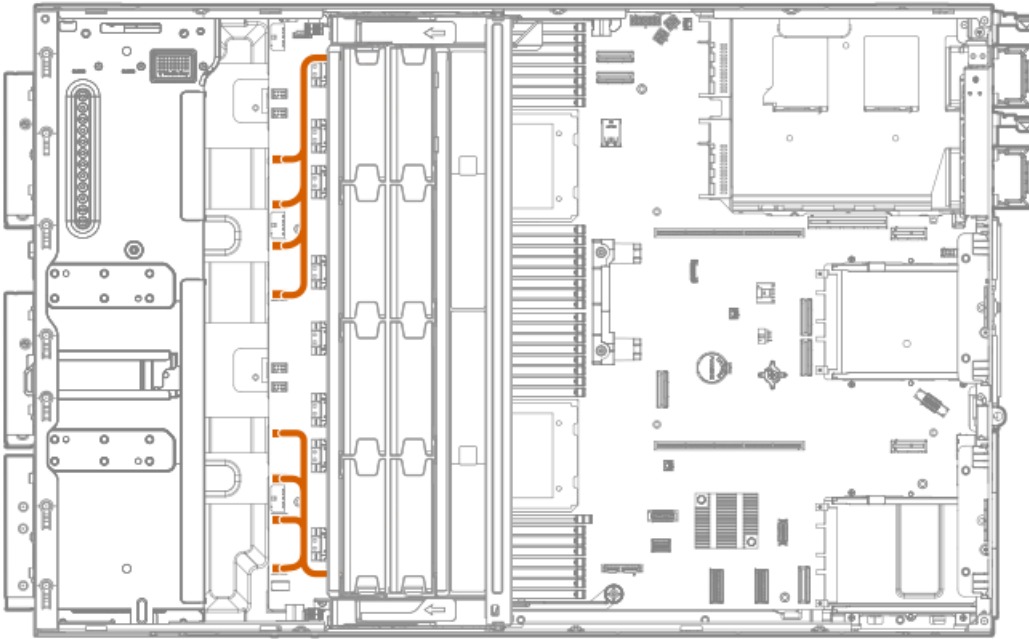

External fans 9–10



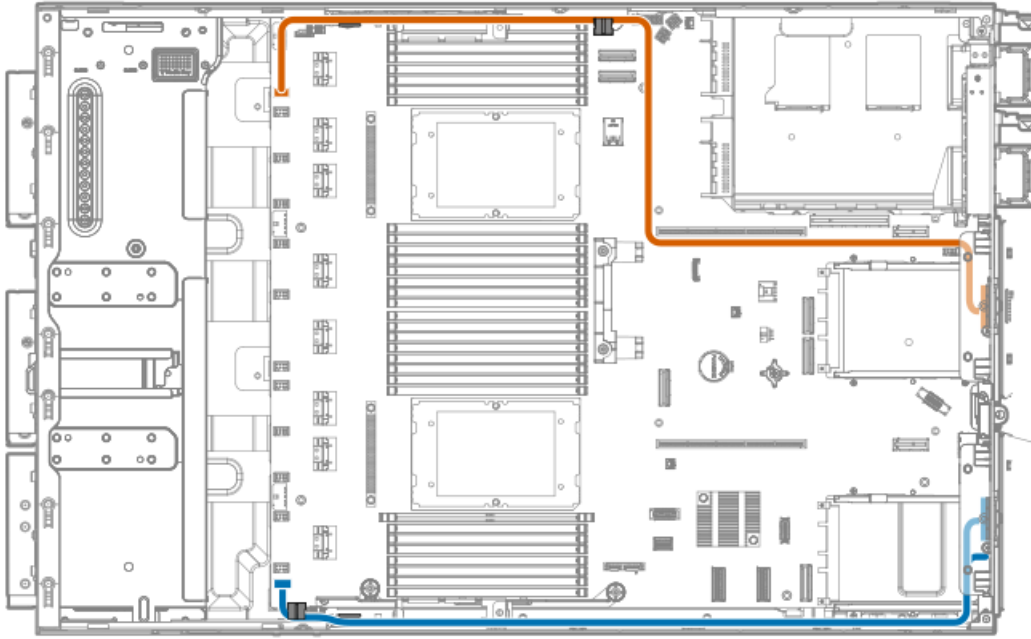

Cable part number	Color	From	To
P45291-001 ¹	Orange	External fan 9	Fan connector 9
	Blue	External fan 10	Fan connector 10

¹ Option kit: P47220-B21

HPE NS204i-u Boot Device cabling

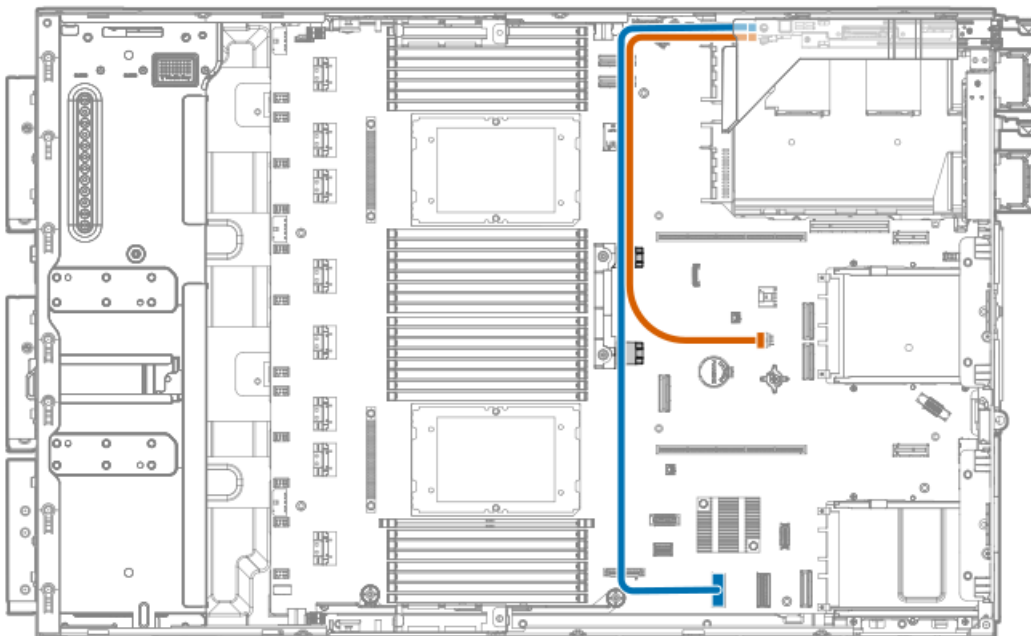

Cable part number	Color	From	To
P54092-001 ¹	Blue	Boot device signal connector	PCH LP SlimSAS port 1
P54089-001 ¹	Orange	Boot device power connector	NS204i-u power connector

¹ Option kit: P48403-B21

OCP upgrade cabling

OCP bandwidth upgrade cabling

The OCP bandwidth upgrade cable is required to support a x16 OCP expansion option.

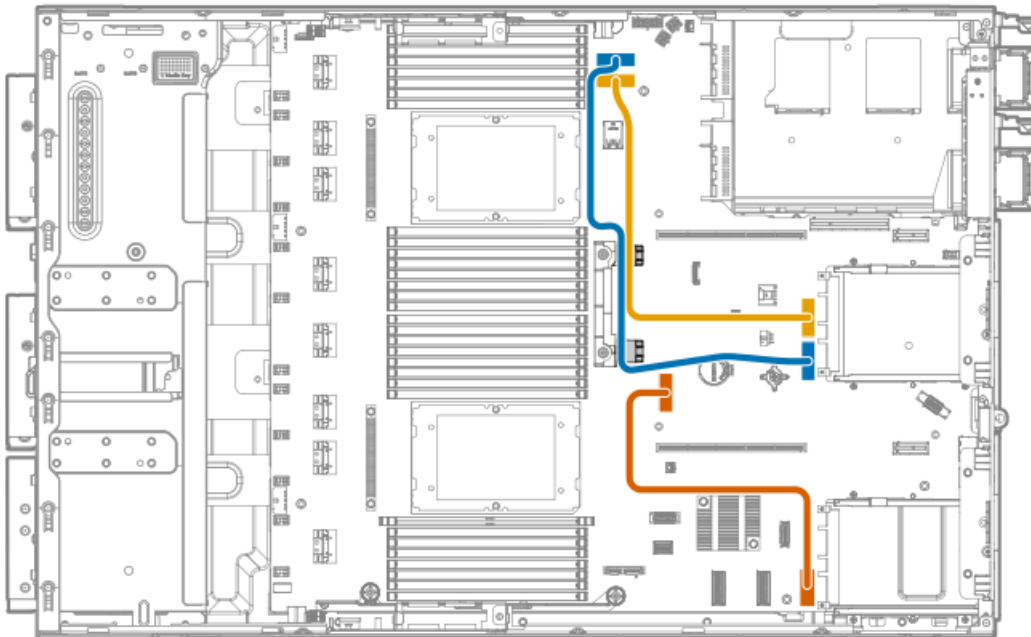

Cable part number	Color	From	To
P43734-001 ¹	Gold	CPU 2 MCIO port 1	Slot 15 OCP port 1
	Blue	CPU 2 MCIO port 2	Slot 15 OCP port 2
P43736-001 ²	Orange	CPU 1 MCIO port 1	Slot 14 OCP port 2

¹ Option kit: P47231-B21

² Option kit: P47230-B21

Dual OCP slot upgrade cabling for single-processor server

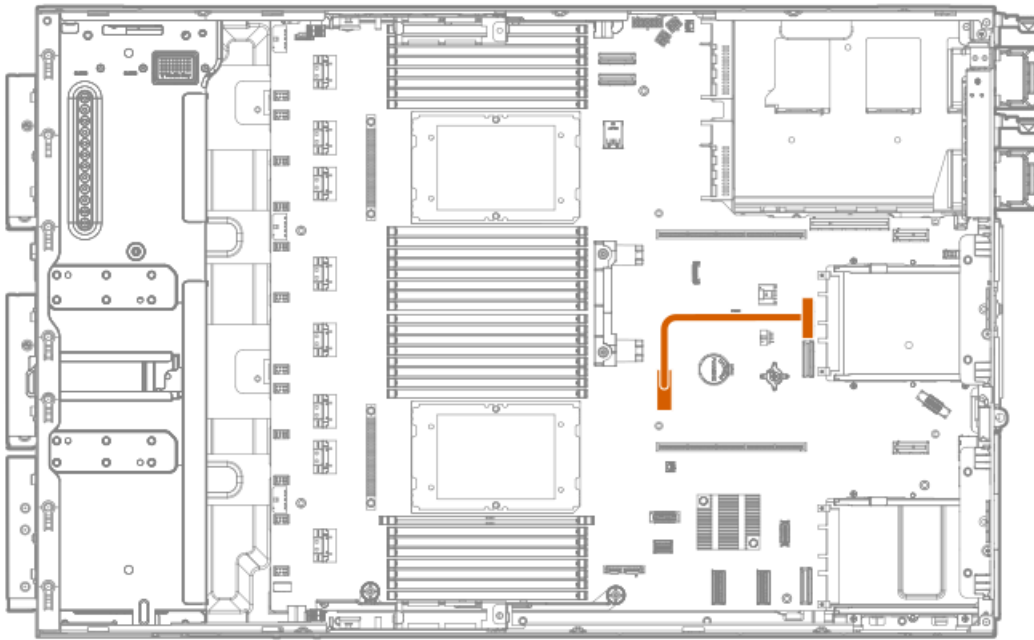

Cable part number	Color	From	To
P43735-001 ¹	Orange	CPU 1 MCIO port 1	Slot 15 OCP port 1

¹ Option kit: P47231-B21

Tertiary riser signal cabling

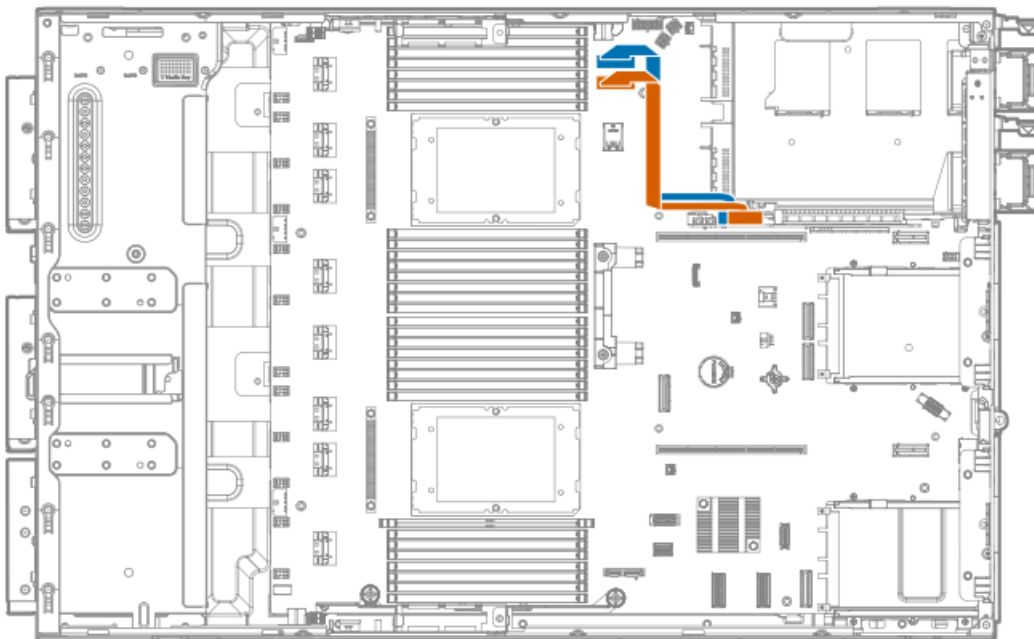

Cable part number	Color	From	To
P52240-001 ¹	Blue	CPU 2 MCIO port 2	PCIe SlimSAS port 3
	Orange	CPU 2 MCIO port 1	PCIe SlimSAS port 1

¹ Option kit: P49693-B21

Serial port cabling

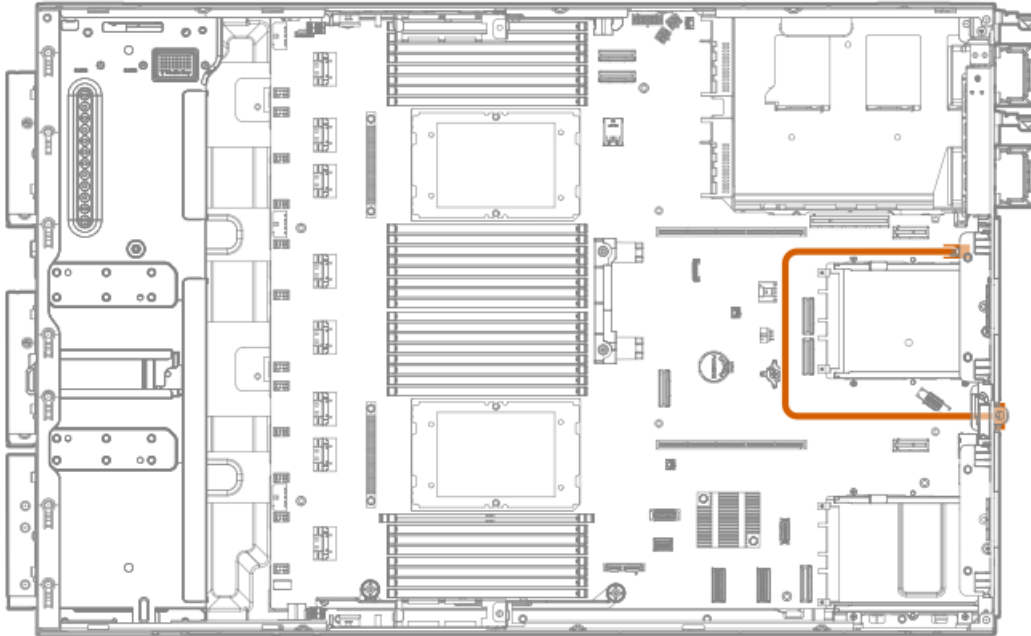

Cable part number	Color	From	To
P45623-001 ¹	Orange	Serial port	Serial port cable connector

¹ Option kit: P55062-B21

Chassis intrusion detection switch cabling



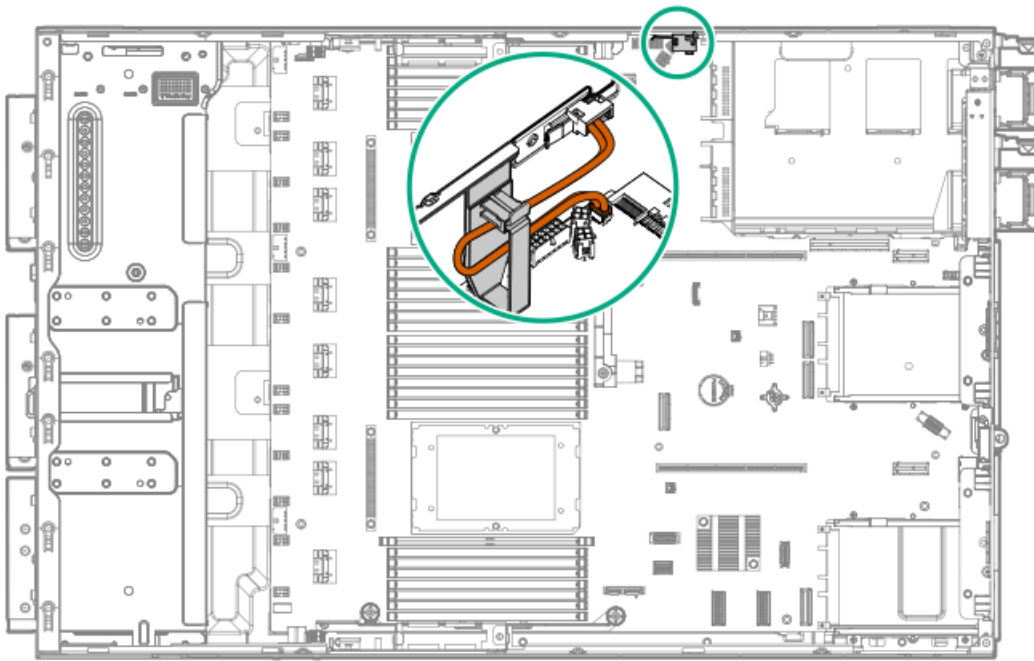

Front I/O cabling

Front I/O cables are preinstalled in the server.

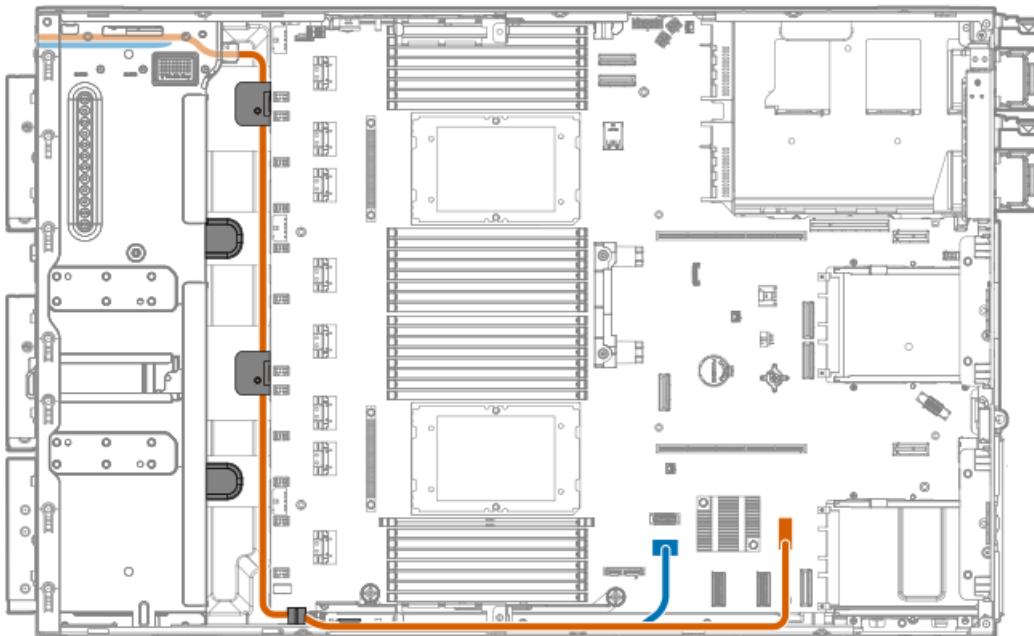

Cable part number	Color	From	To
P45292-001	Orange	Optical drive cage	DisplayPort connector
	Blue		Front I/O & USB 3.2 Gen 1 port connector



Configuration resources

Use the following resources to find documentation for configuring and managing your server.

- Some utilities might not apply to your server. For information about server compatibility with the products listed in this chapter, see the product QuickSpecs (<https://www.hpe.com/info/quickspecs>).
- Products ordered from HPE Factory Express might have already been configured with some or all the configurations in this chapter. To determine if any additional setup is required, see your HPE Factory Express order.
- For the most recent changes, feature enhancements, and bug fixes, see the latest product release notes.

Subtopics

[Updating firmware or system ROM](#)

[Configuring the server](#)

[Configuring storage controllers](#)

[Managing the HPE NS204i-u Boot Device](#)

[Deploying an OS](#)

[Configuring security](#)

[Optimizing the server](#)

[Server management](#)

[Managing Linux-based high performance compute clusters](#)

Updating firmware or system ROM

To	Use
Download service packs	Service Pack for ProLiant (SPP) https://www.hpe.com/servers/spp/download
Deploy service packs to a single server	Smart Update Manager (SUM) https://www.hpe.com/info/sum-docs
Deploy service packs to multiple servers	HPE OneView https://www.hpe.com/support/oneview-docs
<ul style="list-style-type: none">• Enable policy-based management of server or server group firmware for distributed server infrastructure• Monitor server compliance with a configured firmware baseline• Receive automatic iLO firmware updates• Receive baseline update alerts	HPE GreenLake for Compute Ops Management https://www.hpe.com/info/com-docs

Configuring the server

To configure	Use
Single server (GUI)	<ul style="list-style-type: none">• Intelligent Provisioning https://www.hpe.com/info/intelligentprovisioning/docs• iLO remote console or web interface https://www.hpe.com/support/ilo6• UEFI System Utilities https://www.hpe.com/info/UEFI-manuals• HPE GreenLake for Compute Ops Management https://www.hpe.com/info/com-docs
Single server (scripting)	<ul style="list-style-type: none">• RESTful Interface Tool https://www.hpe.com/support/restfulinterface/docs• Python iLO Redfish Library (python-iloest-library) https://github.com/HewlettPackard/python-iloest-library• Scripting Tools for Windows Powershell https://www.hpe.com/info/powershell/docs• iLO RESTful API https://servermanagementportal.ext.hpe.com/docs/redfishservices/ilos/ilo6/• HPE GreenLake for Compute Ops Management API https://developer.greenlake.hpe.com/
Multiple servers (either UI or scripting)	<ul style="list-style-type: none">• HPE OneView ¹ https://www.hpe.com/support/oneview-docs• HPE GreenLake for Compute Ops Management https://www.hpe.com/info/com-docs<ul style="list-style-type: none">◦ Server settings: Define server-specific parameters such as firmware baselines, and then apply them to server groups.◦ Server groups: Organize servers into custom-defined sets with associated server settings, and then apply group-specific policies to create a consistent configuration across the servers in the group.

¹ For servers running HPE OneView, do not use another tool, such as iLO, to delete or change certain settings. For more information about using HPE OneView and iLO to manage the same server, see the iLO user guide at <https://www.hpe.com/support/ilo6>.

Configuring storage controllers

Controller type	Documentation
HPE SR Gen11 controllers	<p>HPE SR Gen11 Controller User Guide</p> <p>https://hpe.com/support/SR-Gen11-UG</p> <p>Configuration guides:</p> <ul style="list-style-type: none"> • HPE Smart Storage Administrator GUI User Guide https://www.hpe.com/support/SSA-UG • HPE Smart Storage Administrator CLI User Guide https://www.hpe.com/support/SSACLI-UG
HPE MR Gen11 controllers	<p>HPE MR Gen11 Controller User Guide</p> <p>https://hpe.com/support/MR-Gen11-UG</p> <p>Configuration guides:</p> <ul style="list-style-type: none"> • HPE MR Storage Administrator User Guide https://www.hpe.com/support/MRSA • HPE StorCLI User Guide https://www.hpe.com/support/StorCLI
Intel VROC for HPE Gen11	<p>Intel Virtual RAID on CPU for HPE Gen11 User Guide</p> <p>https://hpe.com/support/VROC-Gen11-UG</p> <p>OS-specific configuration guides:</p> <ul style="list-style-type: none"> • Intel Virtual RAID on CPU (Intel VROC) for Windows User Guide https://www.intel.com/content/dam/support/us/en/documents/memory-and-storage/338065_Intel_VROC_UserGuide_Windows.pdf • Intel Virtual RAID on CPU (Intel VROC) for Linux User Guide https://www.intel.com/content/dam/support/us/en/documents/memory-and-storage/linux-intel-vroc-userguide-333915.pdf • Intel Volume Management Device Driver for VMware ESXi User Guide https://www.intel.com/content/dam/support/us/en/documents/memory-and-storage/ESXi-Intel-VROC-UserGuide.pdf

Managing the HPE NS204i-u Boot Device

For more information on supported features and maintenance information for the HPE NS204i-u Boot Device, see the HPE NS204i-u Boot Device User Guide:

<https://www.hpe.com/support/NS204-UG>

Deploying an OS

For a list of supported operating systems, see the HPE Servers Support & Certification Matrices:

<https://www.hpe.com/support/Servers-Certification-Matrices>

To	See
Configure the server to boot from a SAN	HPE Boot from SAN Configuration Guide https://www.hpe.com/info/boot-from-san-config-guide
Configure the server to boot from a PXE server	UEFI System Utilities User Guide for HPE ProLiant Gen11 Servers and HPE Synergy https://www.hpe.com/support/UEFIGen11-UG-en
Deploy an OS using iLO virtual media	iLO user guide https://www.hpe.com/support/ilo6
Deploy an OS using Intelligent Provisioning	Intelligent Provisioning user guide https://www.hpe.com/info/intelligentprovisioning/docs

Configuring security

To	See
Implement server security best practices.	<ul style="list-style-type: none">HPE Compute Security Reference Guide https://www.hpe.com/info/server-security-reference-enHPE iLO 6 Security Technology Brief https://www.hpe.com/support/ilo6-security-en
Configure and use the Server Configuration Lock feature on HPE Trusted Supply Chain servers and other servers that have the Server Configuration Lock feature enabled.	Server Configuration Lock User Guide for HPE ProLiant servers and HPE Synergy https://www.hpe.com/info/server-config-lock-UG-en

Optimizing the server

To	See
Optimize server performance through management and tuning features.	HPE Server Performance Management and Tuning Guide https://www.hpe.com/info/server-performance-management-tuning-en
Obtain recommendations for resolving incorrect settings.	HPE InfoSight for Servers User Guide https://www.hpe.com/support/InfoSight-for-Servers-UG-en

Server management

To monitor	See
Single server	HPE iLO https://www.hpe.com/support/ilo6
Multiple servers	HPE OneView https://www.hpe.com/support/oneview-docs
Single or multiple servers	HPE GreenLake for Compute Ops Management https://www.hpe.com/info/com-docs

Managing Linux-based high performance compute clusters

To	Use
Provision, manage, and monitor clusters.	HPE Performance Cluster Manager https://www.hpe.com/support/hpcm_manuals
Optimize your applications.	HPE Performance Analysis Tools https://www.hpe.com/info/perftools
Optimize software library for low latency and high bandwidth, both on-node and off-node, for point-to-point and collective communications.	HPE Cray Programming Environment User Guide https://www.hpe.com/info/cray-pe-user-guides

Troubleshooting

Subtopics

[NMI functionality](#)

[Troubleshooting resources](#)

NMI functionality

An NMI crash dump enables administrators to create crash dump files when a system is not responding to traditional debugging methods.

An analysis of the crash dump log is an essential part of diagnosing reliability problems, such as hanging operating systems, device drivers, and applications. Many crashes freeze a system, and the only available action for administrators is to cycle the system power. Resetting the system erases any information that could support problem analysis, but the NMI feature preserves that information by performing a memory dump before a hard reset.

To force the OS to initiate the NMI handler and generate a crash dump log, the administrator can use the iLO Generate NMI feature.



Troubleshooting resources

Troubleshooting resources are available for HPE Gen11 server products in the following documents:

- Troubleshooting Guide for HPE ProLiant Gen11 servers provides procedures for resolving common problems and comprehensive courses of action for fault isolation and identification, issue resolution, and software maintenance.

<https://www.hpe.com/info/gen11-troubleshooting>

- Integrated Management Log Messages for HPE ProLiant Gen10, Gen10 Plus, and Gen11 servers and HPE Synergy provides IML messages and associated troubleshooting information to resolve critical and cautionary IML events.

<https://www.hpe.com/info/Troubleshooting-IML-en>

System battery replacement

If the server no longer automatically displays the correct date and time, then replace the battery that provides power to the real-time clock. Under normal use, battery life is 5–10 years.

Subtopics

[System battery information](#)

[Removing and replacing the system battery](#)

System battery information

The server contains an internal lithium manganese dioxide, a vanadium pentoxide, or an alkaline battery that provides power to the real-time clock.



WARNING: If this battery is not properly handled, a risk of fire or burning exists. To reduce the risk of personal injury:

- Do not attempt to recharge the battery.
 - Do not expose the battery to temperatures higher than 60°C (140°F).
 - Do not expose the battery to low air pressure as it might lead to explosion or leakage of flammable liquid or gas.
 - Do not disassemble, crush, puncture, short external contacts, or dispose of the battery in fire or water.
-

Removing and replacing the system battery

Prerequisites

Before you perform this procedure, make sure that you have a small flat-bladed, nonconductive tool available.

About this task



IMPORTANT: After replacing the system battery and applying power, wait for 10 minutes before powering on the server. This lead time is required for the server to reset and reinitialize the iLO configuration settings stored in SRAM.

Procedure

1. Power down the server.
2. Remove all power:
 - a. Disconnect each power cord from the power source.
 - b. Disconnect each power cord from the server.
3. Disconnect all peripheral cables from the server.
4. Do one of the following:
 - If the server is in tower mode, place the server on a flat, level surface with the access panel facing up.
 - If the server is in rack mode, remove the server from the rack.
5. Unlock the front bezel.
6. Remove the access panel.
7. If installed, remove the secondary riser cage.
8. Locate the battery on the system board.
9. Remove the system battery:
 - a. Use a small flat-bladed, nonconductive tool to press the battery latch.
 - b. Remove the system battery from the socket.

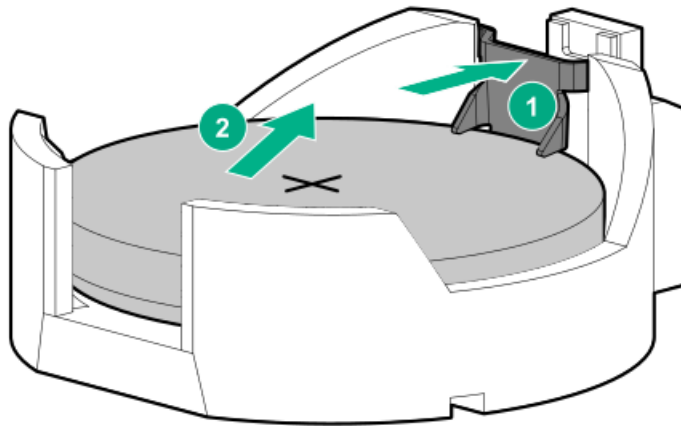

10. Install the system battery:
 - a. With the side of the battery showing the "+" sign facing up, insert the battery into the socket.
 - b. Press the system battery down until it clicks into place.

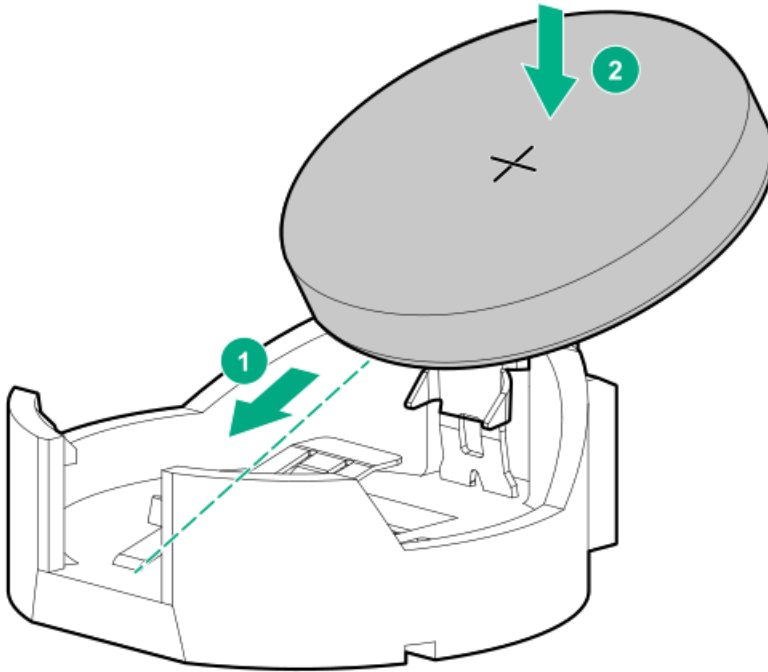

11. Install the secondary riser cage.
12. Install the access panel.
13. Do one of the following:
 - Orient the server back in tower mode.
 - Install the server into the rack.
14. Connect all peripheral cables to the server.
15. Connect each power cord to the server.
16. Connect each power cord to the power source.
17. Wait for 10 minutes for the server to reset and reinitialize the iLO configuration settings stored in SRAM.

i **IMPORTANT:** If iLO security is disabled, the configuration will not be restored. To restore the configuration manually, see <https://www.hpe.com/support/ilo6>.

18. Power up the server.
19. Properly dispose of the old battery.

For more information about proper battery disposal, contact an authorized reseller or an authorized service provider.

Results

The installation is complete.

Safety, warranty, and regulatory information

Subtopics

[Regulatory information](#)

[Warranty information](#)

Regulatory information

To view the regulatory information for your product, view the [Safety and Compliance Information for Server, Storage, Power, Networking, and Rack Products](#), available at the Hewlett Packard Enterprise Support Center:

<https://www.hpe.com/support/Safety-Compliance-EnterpriseProducts>

Additional regulatory information

Hewlett Packard Enterprise is committed to providing our customers with information about the chemical substances in our products as needed to comply with legal requirements such as REACH (Regulation EC No 1907/2006 of the European Parliament and the Council). A chemical information report for this product can be found at:

<https://www.hpe.com/info/reach>

For Hewlett Packard Enterprise product environmental and safety information and compliance data, including RoHS and REACH, see:

<https://www.hpe.com/info/ecodata>

For Hewlett Packard Enterprise environmental information, including company programs, product recycling, and energy efficiency, see:

<https://www.hpe.com/info/environment>

Subtopics

[Notices for Eurasian Economic Union](#)

[Turkey RoHS material content declaration](#)

[Ukraine RoHS material content declaration](#)

Notices for Eurasian Economic Union



Manufacturer and Local Representative Information

Manufacturer information:

Hewlett Packard Enterprise Company, 1701 E Mossy Oaks Road, Spring, TX 77389 U.S.

Local representative information Russian:

- **Russia**
ООО "Хьюлетт Паккард Энтерпрайз", Российская Федерация, 125171, г. Москва, Ленинградское шоссе, 16А, стр.3, Телефон: +7 499 403 4248 Факс: +7 499 403 4677
- **Kazakhstan**
ТОО «Хьюлетт-Паккард (К)», Республика Казахстан, 050040, г. Алматы, Бостандыкский район, проспект Аль-Фараби, 77/7, Телефон/факс: + 7 727 355 35 50

Local representative information Kazakh:

- **Russia**
ЖШС "Хьюлетт Паккард Энтерпрайз", Ресей Федерациясы, 125171, Мәскеу, Ленинград тас жолы, 16А блок 3, Телефон: +7 499 403 4248 Факс: +7 499 403 4677
- **Kazakhstan**
ЖШС «Хьюлетт-Паккард (К)», Қазақстан Республикасы, 050040, Алматы қ., Бостандық ауданы, Эл-Фараби даңғ ылы, 77/7, Телефон/факс: +7 727 355 35 50

Manufacturing date:

The manufacturing date is defined by the serial number.

CCSYWWZZZZ (product serial number format)

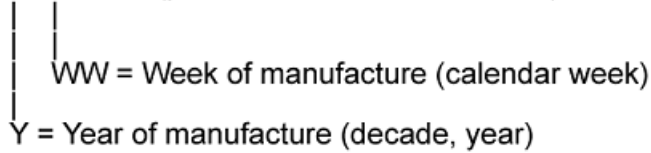

If you need help identifying the manufacturing date, contact tre@hpe.com.

Turkey RoHS material content declaration

Türkiye Cumhuriyeti: AEEE Yönetmeliğine Uygundur

Ukraine RoHS material content declaration

Обладнання відповідає вимогам Технічного регламенту щодо обмеження використання деяких небезпечних речовин в електричному та електронному обладнанні, затвердженого постановою Кабінету Міністрів України від 3 грудня 2008 № 1057

Warranty information

To view the warranty information for your product, see the [warranty check tool](#).

Specifications

Subtopics

[Environmental specifications](#)

[Limited operating inlet ambient temperature requirements](#)

[Mechanical specifications](#)

[Power supply specifications](#)

Environmental specifications



Specifications	Value
Temperature range*	—
Operating	10°C to 35°C (50°F to 95°F)
Nonoperating	-30°C to 60°C (-22°F to 140°F)
Relative humidity (noncondensing)	—
Operating	8% to 90% 28°C (82.4°F) maximum wet bulb temperature, noncondensing
Nonoperating	5% to 95% 38.7°C (101.7°F) maximum wet bulb temperature, noncondensing
Altitude	—
Operating	3050 m (10,000 ft) This value may be limited by the type and number of options installed. Maximum allowable altitude change rate is 457 m/min (1,500 ft/min).
Nonoperating	9144 m (30,000 ft) Maximum allowable altitude change rate is 457 m/min (1,500 ft/min).

Standard operating support

10° to 35°C (50° to 95°F) at sea level with an altitude derating of 1.0°C per every 305 m (1.8°F per every 1,000 ft) above sea level to a maximum of 3,050 m (10,000 ft), no direct sustained sunlight. Maximum rate of change is 20°C/hr (36°F/hr). The upper limit and rate of change may be limited by the type and number of options installed.

System performance during standard operating support might be reduced in the following conditions:

- A fan failure occurs.
- The server operates above 30°C (86°F).

Extended ambient operating support

For approved hardware configurations, the supported system inlet range is extended to be:

- 5° to 10°C (41° to 50°F) and 35° to 40°C (95° to 104°F) at sea level with an altitude derating of 1.0°C per every 175 m (1.8°F per every 574 ft) above 900 m (2,953 ft) to a maximum of 3050 m (10,000 ft).
- 40°C to 45°C (104°F to 113°F) at sea level with an altitude derating of 1.0°C per every 125 m (1.8°F per every 410 ft) above 900 m (2953 ft) to a maximum of 3,050 m (10,000 ft).

The approved hardware configurations for this system are listed in the Extended Ambient Temperature Guidelines for Gen11 HPE ProLiant servers:

<https://www.hpe.com/support/ASHRAEGen11>

Limited operating inlet ambient temperature requirements

The maximum operating inlet ambient temperature value for most components installed in the server is 35°C (95°F). However, installing some components in specific configurations is subject to temperature limitations. To ensure safe and reliable system operation, identify the limited operating inlet ambient temperature required for these configurations.

In the following tables, the processor thermal design power (TDP) is set at a default value. Use the UEFI System Utilities to adjust the TDP setting within preset limits—configurable TDP (cTDP).

From the System Utilities screen, select System Configuration > BIOS/Platform Configuration (RBSU) > Processor Options. Enter the number in milliwatt (mW) for the Processor RAPL wattage value field.

Subtopics

[Limited operating inlet ambient temperature requirements for DDR5 4800 256 GB DIMM](#)

[Limited operating inlet ambient temperature requirements for HPE InfiniBand HDR100 / Ethernet 100GB 2-port QSFP56 PCIe4 x16 Adapter](#)

[Limited operating inlet ambient temperature requirements for HPE NS204i-u Boot Device](#)

[Limited operating inlet ambient temperature requirements for E3.S drive configuration](#)

Limited operating inlet ambient temperature requirements for DDR5 4800 256 GB DIMM

The following temperature values are valid for all drive configurations.

Fan presence	Fan redundancy	Maximum inlet ambient temperature
Fans 2-4	Not supported	25°C (77°F)
Fans 1-4	Not supported	25°C (77°F)
Fans 1-8	Supported	30°C (86°F)

Limited operating inlet ambient temperature requirements for HPE InfiniBand HDR100 / Ethernet 100GB 2-port QSFP56 PCIe4 x16 Adapter

AOC stands for active optical cable, while DAC stands for direct attach copper cable.



IMPORTANT:

High-bandwidth HDR InfiniBand and Ethernet adapters might cause the fans to operate at high speeds to maintain optimum system cooling. This high-speed fan operation can generate excessive fan noise and lead the system to be on standby mode.

Drive configuration	Cable type	Processor TDP	Maximum inlet ambient temperature
4 LFF / 8 SFF	DAC	All	30°C (86°F)
	AOC	≤ 270 W	30°C (86°F)
		> 270 W	25°C (77°F)
8 LFF / 16 SFF	DAC	All	30°C (86°F)
	AOC	≤ 270 W	30°C (86°F)
		> 270 W	25°C (77°F)
8 NVMe x4	DAC	All	30°C (86°F)
	AOC	All	25°C (77°F)
12 LFF / 24 SFF	DAC	All	30°C (86°F)
	AOC	All	25°C (77°F)

Limited operating inlet ambient temperature requirements for HPE NS204i-u Boot Device

i IMPORTANT:

When used in high performance compute workloads, the HPE NS204i-u Boot Device might cause the fans to operate at high speeds to maintain optimum system cooling. This high-speed fan operation can generate excessive fan noise and lead the system to be on standby mode.

Drive configuration	Fan configuration	Maximum inlet ambient temperature
4 LFF / 8 SFF	Four fans (Fans 1–4), nonredundant	30°C (86°F)
	Eight fans (Fans 1–8), redundant	30°C (86°F)
8 LFF / 16 SFF	Four fans (Fans 1–4), nonredundant	30°C (86°F)
	Eight fans (Fans 1–8), redundant	30°C (86°F)
8 NVMe x4	Four fans (Fans 1–4), nonredundant	30°C (86°F)
	Eight fans (Fans 1–8), redundant	30°C (86°F)
12 LFF / 24 SFF	Four fans (Fans 1–4), nonredundant	25°C (77°F)
	Eight fans (Fans 1–8), redundant	30°C (86°F)

Limited operating inlet ambient temperature requirements for E3.S drive configuration

With eight internal fans and external fan 10 are installed, the maximum operating inlet ambient temperature value for the E3.S drive configuration is 25°C (77°F).

Mechanical specifications

Tower orientation

Specification	Value
Dimensions	—
Height (with chassis feet)	46.2 cm (18.19 in)
Depth	71.26 cm (28.06 in)
Width	17.4 cm (6.85 in)
Weight, approximate values	—
Minimum	23.48 kg (51.76 lb)
Maximum	36.61 kg (80.71 lb)

Rack orientation

Specification	Value
Dimensions	—
Height	17.4 cm (6.85 in)
Depth	71.26 cm (28.06 in)
Width	44.50 cm (17.52 in)
Weight, approximate values	—
Minimum	23.48 kg (51.76 lb)
Maximum	36.61 kg (80.71 lb)

Power supply specifications

Depending on the installed options and the regional location where the server was purchased, the server can be configured with one of the following power supplies. For detailed power supply specifications, see the QuickSpecs on the [Hewlett Packard Enterprise website](#).

Subtopics

[HPE 500 W Flex Slot Platinum Hot-plug Low Halogen Power Supply](#)

[HPE 800 W Flex Slot Platinum Hot-plug Low Halogen Power Supply](#)

[HPE 1000 W Flex Slot Titanium Hot-plug Power Supply](#)

[HPE 1600 W Flex Slot Platinum Hot-plug Low Halogen Power Supply](#)

[HPE 1600 W Flex Slot -48 VDC Hot-plug Power Supply](#)

[HPE 1800-2200 W Flex Slot Titanium Power Supply](#)

HPE 500 W Flex Slot Platinum Hot-plug Low Halogen Power Supply



Specification	Value
Input requirements	—
Rated input voltage	100 VAC to 240 VAC 240 VDC for China
Rated input frequency	50 Hz to 60 Hz Not applicable to 240 VDC
Rated input current	5.8 A at 100 VAC 2.8 A at 200 VAC 2.4 A at 240 VDC for China
Maximum rated input power	580 W at 100 VAC 560 W at 200 VAC 558 W at 240 VDC for China
BTUs per hour	1999 at 100 VAC 1912 at 200 VAC 1904 at 240 VDC for China
Power supply output	—
Rated steady-state power	500 W at 100 VAC to 127 VAC input 500 W at 100 VAC to 240 VAC input 500 W at 240 VDC input for China
Maximum peak power	500 W at 100 VAC to 127 VAC input 500 W at 100 VAC to 240 VAC input 500 W at 240 VDC input for China

HPE 800 W Flex Slot Platinum Hot-plug Low Halogen Power Supply



Specification	Value
Input requirements	—
Rated input voltage	100 VAC to 127 VAC 200 VAC to 240 VAC 240 VDC for China only
Rated input frequency	50 Hz to 60 Hz Not applicable to 240 VDC
Rated input current	9.4 A at 100 VAC 4.5 A at 200 VAC 3.8 A at 240 VDC for China only
Maximum rated input power	940 W at 100 VAC 900 W at 200 VAC 897 W at 240 VDC for China only
BTUs per hour	3067 at 100 VAC 2958 at 200 VAC 2949 at 240 VAC for China only
Power supply output	—
Rated steady-state power	800 W at 100 VAC to 127 VAC input 800 W at 100 VAC to 240 VAC input 800 W at 240 VDC input for China only
Maximum peak power	800 W at 100 VAC to 127 VAC input 800 W at 100 VAC to 240 VAC input 800 W at 240 VDC input for China only

HPE 1000 W Flex Slot Titanium Hot-plug Power Supply



Specification	Value
Input requirements	—
Rated input voltage	100 VAC to 127 VAC 200 VAC to 240 VAC 240 VDC for China
Rated input frequency	50 Hz to 60 Hz
Rated input current	11.3 A at 100 VAC 6.1 A at 200 VAC
Maximum rated input power	1130 W at 100 VAC 1090 W at 200 VAC
BTUs per hour	3764 at 100 VAC 3629 at 200 VAC
Power supply output	—
Rated steady-state power	1000 W at 100 VAC to 127 VAC 1000 W at 200 VAC to 240 VAC input
Maximum peak power	1000 W at 100 VAC to 127 VAC 1000 W at 200 VAC to 240 VAC

HPE 1600 W Flex Slot Platinum Hot-plug Low Halogen Power Supply

Specification	Value
Input requirements	—
Rated input voltage	200 VAC to 240 VAC 240 VDC for China only
Rated input frequency	50 Hz to 60 Hz
Rated input current	8.7 A at 200 VAC 7.5 A at 230 VAC 7.2 A at 240 VDC
Maximum rated input power	1734 W at 200 VAC 1720 W at 240 VAC
BTUs per hour	5918 at 200 VAC 5891 at 230 VAC
Power supply output	—
Rated steady-state power	1600 W at 200 VAC to 240 VAC input 1600 W at 240 VDC input
Maximum peak power	2200 W for 1 ms (turbo mode) at 200 VAC to 240 VAC input

HPE 1600 W Flex Slot -48 VDC Hot-plug Power Supply

Specification	Value
Input requirements	—
Rated input voltage	-40 VDC to -72 VDC
Rated input frequency	DC
Nominal input current	45 A DC at -40 VDC input 36.6 A DC at -48 VDC input 24.4 A DC at -72 VDC input
Maximum Rated Input Wattage Rating	1798 W at -40 VDC input 1758 W at -48 VDC input 1755 W at -72 VDC input
BTUs per hour	6026 at -40 VDC input 6000 at -48 VDC input 5989 at -72 VDC input
Power supply output	—
Rated steady-state power	1600 W at -40 VDC to -72 VDC
Maximum peak power	1600 W at -40 VDC to -72 VDC

HPE 1800-2200 W Flex Slot Titanium Power Supply



Specification	Value
Input requirements	—
Rated input voltage	200 VAC to 240 VAC 240 VDC for China only
Rated input frequency	50 Hz to 60 Hz
Rated input current	10 A at 200 VAC 10 A at 240 VAC 10 A at 240 VDC for China only
Maximum rated input power	1946 W at 200 VAC 2375 W at 240 VAC 2375 W at 240 VDC for China only
BTUs per hour	6497 at 200 VAC 7962 at 240 VAC
Power supply output	—
Rated steady-state power	1800 W at 200 VAC 2200 W at 240 VAC
Maximum peak power	2200 W for 1 ms (turbo mode) at 200 VAC to 240 VAC input

Websites

General websites

Single Point of Connectivity Knowledge (SPOCK) Storage compatibility matrix

<https://www.hpe.com/storage/spock>

Product white papers and analyst reports

<https://www.hpe.com/us/en/resource-library>

For additional websites, see [Support and other resources](#).

Product websites

HPE ProLiant ML350 Gen11 Server user documents

<https://www.hpe.com/info/ml350gen11-docs>

Support and other resources

Subtopics

[Accessing Hewlett Packard Enterprise Support](#)

[HPE product registration](#)

[Accessing updates](#)

[Customer self repair](#)

[Remote support](#)

[Documentation feedback](#)

Accessing Hewlett Packard Enterprise Support

- For live assistance, go to the Contact Hewlett Packard Enterprise Worldwide website:

<https://www.hpe.com/info/assistance>

- To access documentation and support services, go to the Hewlett Packard Enterprise Support Center website:

<https://www.hpe.com/support/hpesc>

Information to collect

- Technical support registration number (if applicable)
- Product name, model or version, and serial number
- Operating system name and version
- Firmware version
- Error messages
- Product-specific reports and logs
- Add-on products or components
- Third-party products or components

HPE product registration

To gain the full benefits of the Hewlett Packard Enterprise Support Center and your purchased support services, add your contracts and products to your account on the HPESC.

- When you add your contracts and products, you receive enhanced personalization, workspace alerts, insights through the dashboards, and easier management of your environment.
- You will also receive recommendations and tailored product knowledge to self-solve any issues, as well as streamlined case creation for faster time to resolution when you must create a case.

To learn how to add your contracts and products, see <https://www.hpe.com/info/add-products-contracts>.

Accessing updates

- Some software products provide a mechanism for accessing software updates through the product interface. Review your product documentation to identify the recommended software update method.
- To download product updates:

Hewlett Packard Enterprise Support Center

<https://www.hpe.com/support/hpesc>

My HPE Software Center

<https://www.hpe.com/software/hpesoftwarecenter>

- To subscribe to eNewsletters and alerts:

<https://www.hpe.com/support/e-updates>

- To view and update your entitlements, and to link your contracts and warranties with your profile, go to the Hewlett Packard Enterprise Support Center More Information on Access to Support Materials page:

<https://www.hpe.com/support/AccessToSupportMaterials>

i IMPORTANT:

Access to some updates might require product entitlement when accessed through the Hewlett Packard Enterprise Support Center. You must have an HPE Account set up with relevant entitlements.

Customer self repair

Hewlett Packard Enterprise customer self repair (CSR) programs allow you to repair your product. If a CSR part needs to be replaced, it will be shipped directly to you so that you can install it at your convenience. Some parts do not qualify for CSR.

For more information about CSR, contact your local service provider.

Remote support

Remote support is available with supported devices as part of your warranty or contractual support agreement. It provides intelligent event diagnosis, and automatic, secure submission of hardware event notifications to Hewlett Packard Enterprise, which initiates a fast and accurate resolution based on the service level of your product. Hewlett Packard Enterprise strongly recommends that you register your device for remote support.

If your product includes additional remote support details, use search to locate that information.

HPE Get Connected

<https://www.hpe.com/services/getconnected>

HPE Tech Care Service

<https://www.hpe.com/services/techcare>

HPE Complete Care Service

<https://www.hpe.com/services/complecare>

Documentation feedback

Hewlett Packard Enterprise is committed to providing documentation that meets your needs. To help us improve the documentation, use the Feedback button and icons (at the bottom of an opened document) on the Hewlett Packard Enterprise Support Center portal (<https://www.hpe.com/support/hpesc>) to send any errors, suggestions, or comments. This process captures all document information.