

JP1 Version 13

**JP1/Automatic Job Management System 3
Linkage Guide**

3021-3-L50-10(E)

Notices

■ Relevant program products

For details about the applicable OS versions, and the service packs and patches required for JP1/Automatic Job Management System 3, see the *Release Notes*.

JP1/Automatic Job Management System 3 - Manager (For Windows):

P-2A12-3KDL JP1/Automatic Job Management System 3 - Manager version 13-10

The above product includes the following:

P-CC2A12-4KDL JP1/Automatic Job Management System 3 - Manager version 13-10 (For Windows Server 2022, Windows Server 2019, Windows Server 2016)

P-CC2912-39DL JP1/Automatic Job Management System 3 - Web Console version 13-10 (For Windows Server 2022, Windows Server 2019, Windows Server 2016)

P-CC8412-39DL JP1/Automatic Job Management System 3 - Web Console version 13-10 (For Linux 7, Linux 8, Linux 9, Oracle Linux 7, Oracle Linux 8, Oracle Linux 9, SUSE Linux 12, SUSE Linux 15)

P-CC2A12-3NDL JP1/Automatic Job Management System 3 - Print Option Manager version 13-10 (For Windows Server 2022, Windows Server 2019, Windows Server 2016)

P-CC2A2C-6LDL JP1/Base version 13-10 (For Windows Server 2022, Windows Server 2019, Windows Server 2016)

JP1/Automatic Job Management System 3 - Manager (For Linux):

P-8412-3KDL JP1/Automatic Job Management System 3 - Manager version 13-10

The above product includes the following:

P-CC8412-4KDL JP1/Automatic Job Management System 3 - Manager version 13-10 (For Linux 7, Linux 8, Linux 9, Oracle Linux 7, Oracle Linux 8, Oracle Linux 9, SUSE Linux 12, SUSE Linux 15)

P-CC2912-39DL JP1/Automatic Job Management System 3 - Web Console version 13-10 (For Windows Server 2022, Windows Server 2019, Windows Server 2016)

P-CC8412-39DL JP1/Automatic Job Management System 3 - Web Console version 13-10 (For Linux 7, Linux 8, Linux 9, Oracle Linux 7, Oracle Linux 8, Oracle Linux 9, SUSE Linux 12, SUSE Linux 15)

P-CC8412-3NDL JP1/Automatic Job Management System 3 - Print Option Manager version 13-10 (For Linux 7, Linux 8, Linux 9, Oracle Linux 7, Oracle Linux 8, Oracle Linux 9, SUSE Linux 12, SUSE Linux 15)

P-CC842C-6LDL JP1/Base version 13-10 (For Linux 7, Linux 8, Linux 9, Oracle Linux 7, Oracle Linux 8, Oracle Linux 9, SUSE Linux 12, SUSE Linux 15)

JP1/Automatic Job Management System 3 - Agent (For Windows):

P-2A12-33DL JP1/Automatic Job Management System 3 - Agent version 13-10

The above product includes the following:

P-CC2A12-43DL JP1/Automatic Job Management System 3 - Agent version 13-10 (For Windows Server 2022, Windows Server 2019, Windows Server 2016)

P-CC2A2C-6LDL JP1/Base version 13-10 (For Windows Server 2022, Windows Server 2019, Windows Server 2016)

JP1/Automatic Job Management System 3 - Agent (For AIX):

P-1M12-33DL JP1/Automatic Job Management System 3 - Agent version 13-10

The above product includes the following:

P-CC1M12-43DL JP1/Automatic Job Management System 3 - Agent version 13-10 (For AIX)

P-CC1M2C-6LDL JP1/Base version 13-10 (For AIX)

JP1/Automatic Job Management System 3 - Agent (For Linux):

P-8412-33DL JP1/Automatic Job Management System 3 - Agent version 13-10

The above product includes the following:

P-CC8412-43DL JP1/Automatic Job Management System 3 - Agent version 13-10 (For Linux 7, Linux 8, Linux 9, Oracle Linux 7, Oracle Linux 8, Oracle Linux 9, SUSE Linux 12, SUSE Linux 15)

P-CC842C-6LDL JP1/Base version 13-10 (For Linux 7, Linux 8, Linux 9, Oracle Linux 7, Oracle Linux 8, Oracle Linux 9, SUSE Linux 12, SUSE Linux 15)

JP1/Automatic Job Management System 3 - Agent Minimal Edition (For Windows):

P-2A12-38DL JP1/Automatic Job Management System 3 - Agent Minimal Edition version 13-10

The above product includes the following:

P-CC2A12-48DL JP1/Automatic Job Management System 3 - Agent Minimal Edition version 13-10 (For Windows Server 2022, Windows Server 2019, Windows Server 2016)

P-CC2A2C-6LDL JP1/Base version 13-10 (For Windows Server 2022, Windows Server 2019, Windows Server 2016)

JP1/Automatic Job Management System 3 - Agent Minimal Edition (For Linux):

P-8412-38DL JP1/Automatic Job Management System 3 - Agent Minimal Edition version 13-10

The above product includes the following:

P-CC8412-48DL JP1/Automatic Job Management System 3 - Agent Minimal Edition version 13-10 (For Linux 7, Linux 8, Linux 9, Oracle Linux 7, Oracle Linux 8, Oracle Linux 9, SUSE Linux 12, SUSE Linux 15)

P-CC842C-6LDL JP1/Base version 13-10 (For Linux 7, Linux 8, Linux 9, Oracle Linux 7, Oracle Linux 8, Oracle Linux 9, SUSE Linux 12, SUSE Linux 15)

JP1/Automatic Job Management System 3 - View (For Windows):

P-2A12-34DL JP1/Automatic Job Management System 3 - View version 13-10

The above product includes the following:

P-CC2A12-44DL JP1/Automatic Job Management System 3 - View version 13-10 (For Windows Server 2022, Windows Server 2019, Windows Server 2016, Windows 11, Windows 10)

P-CC2A12-3MDL JP1/Automatic Job Management System 3 - Print Option version 13-10 (For Windows Server 2022, Windows Server 2019, Windows Server 2016, Windows 11, Windows 10)

■ Trademarks

HITACHI, JP1, Job Management Partner 1, uCosminexus, HiRDB are either trademarks or registered trademarks of Hitachi, Ltd. in Japan and other countries.

Other company and product names mentioned in this document may be the trademarks of their respective owners.

This product includes software developed by the Apache Software Foundation (<http://www.apache.org/>).

Portions of this software were developed at the National Center for Supercomputing Applications (NCSA) at the University of Illinois at Urbana-Champaign.

This product includes software developed by the University of California, Berkeley and its contributors.

This software contains code derived from the RSA Data Security Inc. MD5 Message-Digest Algorithm, including various modifications by Spyglass Inc., Carnegie Mellon University, and Bell Communications Research, Inc (Bellcore).

Regular expression support is provided by the PCRE library package, which is open source software, written by Philip Hazel, and copyright by the University of Cambridge, England.

The original software is available from <ftp://ftp.csx.cam.ac.uk/pub/software/programming/pcre/>

1. This product includes software developed by the OpenSSL Project for use in the OpenSSL Toolkit. (<http://www.openssl.org/>)

2. This product includes cryptographic software written by Eric Young (ey@cryptsoft.com)

3. This product includes software written by Tim Hudson (tjh@cryptsoft.com)

4. This product includes the OpenSSL Toolkit software used under OpenSSL License and Original SSLeay License. OpenSSL License and Original SSLeay License are as follow:

LICENSE ISSUES

=====

The OpenSSL toolkit stays under a double license, i.e. both the conditions of the OpenSSL License and the original SSLeay license apply to the toolkit.

See below for the actual license texts.

OpenSSL License

/* =====

* Copyright (c) 1998-2019 The OpenSSL Project. All rights reserved.

*

* Redistribution and use in source and binary forms, with or without
* modification, are permitted provided that the following conditions
* are met:

*

* 1. Redistributions of source code must retain the above copyright
* notice, this list of conditions and the following disclaimer.

*

* 2. Redistributions in binary form must reproduce the above copyright
* notice, this list of conditions and the following disclaimer in
* the documentation and/or other materials provided with the
* distribution.

*

* 3. All advertising materials mentioning features or use of this
* software must display the following acknowledgment:
* "This product includes software developed by the OpenSSL Project
* for use in the OpenSSL Toolkit. (<http://www.openssl.org/>)"

*

* 4. The names "OpenSSL Toolkit" and "OpenSSL Project" must not be used to
* endorse or promote products derived from this software without
* prior written permission. For written permission, please contact
* openssl-core@openssl.org.

```

*
* 5. Products derived from this software may not be called "OpenSSL"
* nor may "OpenSSL" appear in their names without prior written
* permission of the OpenSSL Project.
*
* 6. Redistributions of any form whatsoever must retain the following
* acknowledgment:
* "This product includes software developed by the OpenSSL Project
* for use in the OpenSSL Toolkit (http://www.openssl.org/)"
*
* THIS SOFTWARE IS PROVIDED BY THE OpenSSL PROJECT ``AS IS" AND ANY
* EXPRESSED OR IMPLIED WARRANTIES, INCLUDING, BUT NOT LIMITED TO, THE
* IMPLIED WARRANTIES OF MERCHANTABILITY AND FITNESS FOR A PARTICULAR
* PURPOSE ARE DISCLAIMED. IN NO EVENT SHALL THE OpenSSL PROJECT OR
* ITS CONTRIBUTORS BE LIABLE FOR ANY DIRECT, INDIRECT, INCIDENTAL,
* SPECIAL, EXEMPLARY, OR CONSEQUENTIAL DAMAGES (INCLUDING, BUT
* NOT LIMITED TO, PROCUREMENT OF SUBSTITUTE GOODS OR SERVICES;
* LOSS OF USE, DATA, OR PROFITS; OR BUSINESS INTERRUPTION)
* HOWEVER CAUSED AND ON ANY THEORY OF LIABILITY, WHETHER IN CONTRACT,
* STRICT LIABILITY, OR TORT (INCLUDING NEGLIGENCE OR OTHERWISE)
* ARISING IN ANY WAY OUT OF THE USE OF THIS SOFTWARE, EVEN IF ADVISED
* OF THE POSSIBILITY OF SUCH DAMAGE.
* =====
*
* This product includes cryptographic software written by Eric Young
* (eay@cryptsoft.com). This product includes software written by Tim
* Hudson (tjh@cryptsoft.com).
*
*/
Original SSLeay License
-----
/* Copyright (C) 1995-1998 Eric Young (eay@cryptsoft.com)
* All rights reserved.
*
* This package is an SSL implementation written
* by Eric Young (eay@cryptsoft.com).
* The implementation was written so as to conform with Netscapes SSL.
*
* This library is free for commercial and non-commercial use as long as
* the following conditions are aheared to. The following conditions
* apply to all code found in this distribution, be it the RC4, RSA,
* lhash, DES, etc., code; not just the SSL code. The SSL documentation

```

- * included with this distribution is covered by the same copyright terms
- * except that the holder is Tim Hudson (tjh@cryptsoft.com).
- *
- * Copyright remains Eric Young's, and as such any Copyright notices in
- * the code are not to be removed.
- * If this package is used in a product, Eric Young should be given attribution
- * as the author of the parts of the library used.
- * This can be in the form of a textual message at program startup or
- * in documentation (online or textual) provided with the package.
- *
- * Redistribution and use in source and binary forms, with or without
- * modification, are permitted provided that the following conditions
- * are met:
- * 1. Redistributions of source code must retain the copyright
- * notice, this list of conditions and the following disclaimer.
- * 2. Redistributions in binary form must reproduce the above copyright
- * notice, this list of conditions and the following disclaimer in the
- * documentation and/or other materials provided with the distribution.
- * 3. All advertising materials mentioning features or use of this software
- * must display the following acknowledgement:
- * "This product includes cryptographic software written by
- * Eric Young (eay@cryptsoft.com)"
- * The word 'cryptographic' can be left out if the routines from the library
- * being used are not cryptographic related :-).
- * 4. If you include any Windows specific code (or a derivative thereof) from
- * the apps directory (application code) you must include an acknowledgement:
- * "This product includes software written by Tim Hudson (tjh@cryptsoft.com)"
- *
- * THIS SOFTWARE IS PROVIDED BY ERIC YOUNG ``AS IS" AND
- * ANY EXPRESS OR IMPLIED WARRANTIES, INCLUDING, BUT NOT LIMITED TO, THE
- * IMPLIED WARRANTIES OF MERCHANTABILITY AND FITNESS FOR A PARTICULAR PURPOSE
- * ARE DISCLAIMED. IN NO EVENT SHALL THE AUTHOR OR CONTRIBUTORS BE LIABLE
- * FOR ANY DIRECT, INDIRECT, INCIDENTAL, SPECIAL, EXEMPLARY, OR CONSEQUENTIAL
- * DAMAGES (INCLUDING, BUT NOT LIMITED TO, PROCUREMENT OF SUBSTITUTE GOODS
- * OR SERVICES; LOSS OF USE, DATA, OR PROFITS; OR BUSINESS INTERRUPTION)
- * HOWEVER CAUSED AND ON ANY THEORY OF LIABILITY, WHETHER IN CONTRACT, STRICT
- * LIABILITY, OR TORT (INCLUDING NEGLIGENCE OR OTHERWISE) ARISING IN ANY WAY
- * OUT OF THE USE OF THIS SOFTWARE, EVEN IF ADVISED OF THE POSSIBILITY OF
- * SUCH DAMAGE.
- *
- * The licence and distribution terms for any publically available version or
- * derivative of this code cannot be changed. i.e. this code cannot simply be

* copied and put under another distribution licence

* [including the GNU Public Licence.]

*/

This product includes the OpenSSL library.

The OpenSSL library is licensed under Apache License, Version 2.0.

<https://www.apache.org/licenses/LICENSE-2.0>

This product includes software developed by the Java Apache Project for use in the Apache JServ servlet engine project (<http://java.apache.org/>).

This product includes software developed by IAIK of Graz University of Technology.

This product includes software developed by Daisuke Okajima and Kohsuke Kawaguchi (<http://relaxngcc.sf.net/>).

This product includes software developed by Andy Clark.

Java is a registered trademark of Oracle and/or its affiliates.



■ Microsoft product name abbreviations

This manual uses the following abbreviations for Microsoft product names.

Abbreviation	Full name or meaning
Excel	Microsoft(R) Excel
	Microsoft(R) Office Excel
Exchange Server	Microsoft(R) Exchange 2000 Enterprise Server
	Microsoft(R) Exchange 2000 Server
	Microsoft(R) Exchange Server
Internet Explorer	Windows(R) Internet Explorer(R)
Microsoft Edge	Microsoft(R) Edge
Microsoft SQL Server	Microsoft(R) SQL Server
	Microsoft(R) SQL Server Enterprise Edition
MSMQ	Microsoft(R) Message Queue Server

Abbreviation		Full name or meaning
Outlook	Outlook 2016	Microsoft(R) Office Outlook(R) 2016
	Outlook 2019	Microsoft(R) Office Outlook(R) 2019
	Outlook 2021	Microsoft(R) Office Outlook(R) 2021
Outlook Express		Microsoft(R) Outlook(R) Express
Windows 10		Windows(R) 10 Enterprise
		Windows(R) 10 Pro
		Windows(R) 10 Home
Windows 11		Windows(R) 11 Enterprise
		Windows(R) 11 Pro
		Windows(R) 11 Home
Windows Server 2016		Microsoft(R) Windows Server(R) 2016 Datacenter
		Microsoft(R) Windows Server(R) 2016 Standard
Windows Server 2019		Microsoft(R) Windows Server(R) 2019 Datacenter
		Microsoft(R) Windows Server(R) 2019 Standard
Windows Server 2022		Microsoft(R) Windows Server(R) 2022 Datacenter
		Microsoft(R) Windows Server(R) 2022 Standard

Windows is sometimes used generically, referring to Windows Server 2022, Windows Server 2019, Windows Server 2016, Windows 11, and Windows 10.

■ Restrictions

Information in this document is subject to change without notice and does not represent a commitment on the part of Hitachi. The software described in this manual is furnished according to a license agreement with Hitachi. The license agreement contains all of the terms and conditions governing your use of the software and documentation, including all warranty rights, limitations of liability, and disclaimers of warranty.

Material contained in this document may describe Hitachi products not available or features not available in your country.

No part of this material may be reproduced in any form or by any means without permission in writing from the publisher.

■ Issued

Sep. 2024: 3021-3-L50-10(E)

■ Copyright

Copyright (C) 2023, 2024, Hitachi, Ltd.

Copyright (C) 2023, 2024, Hitachi Solutions, Ltd.



Summary of amendments

For details about the amendments, see the manual *JP1/Automatic Job Management System 3 Overview*.

Preface

This manual describes the linkage functionality of JP1/Automatic Job Management System 3 with other products (abbreviated hereafter to *JP1/AJS3*).

For details on the prerequisites before reading this manual, see the manual *JP1/Automatic Job Management System 3 Overview*.

■ Organization of this manual

This manual organized into the following chapters. The manual is a common reference for all supported operating systems. Any platform-dependent differences in functionality are noted in the manual.

1. Overview

Chapter 1 gives an overview of linking other products.

2. Linking Mail Systems

Chapter 2 describes how to link a mail system to send and receive mail.

3. Adding Custom Jobs

Chapter 3 describes how to add custom jobs to link other products.

4. Linking JP1/FTP

Chapter 4 describes how to link JP1/FTP to automatically transfer files.

5. Linking ERP Systems

Chapter 5 describes how to link ERP systems to automate ERP system processing.

6. Linking Mainframes Using JP1/OJE

Chapter 6 describes how to link JP1/OJE to execute mainframe processing.

7. Linking hp NonStop Server (Windows Only)

Chapter 7 describes how to link HP NonStop Server to execute jobs.

8. Linking JP1/Script

Chapter 8 describes how to execute a script file created with JP1/Script.

9. Monitoring Jobnets Using JP1/IM and JP1/IM2

Chapter 9 describes how to use JP1/IM and JP1/IM2 to monitor the execution state of JP1/AJS3.

If you are using JP1/IM3, the descriptions related to JP1/IM2 in this manual apply to JP1/IM3 unless otherwise specified. Differences between JP1/IM2 and JP1/IM3 are clearly specified in this manual.

10. Automatic Distribution Using JP1/Software Distribution

Chapter 10 describes how to use JP1/Software Distribution to distribute unit and calendar definition information.

11. Linking JP1/DH - AJE

Chapter 11 describes how to link JP1/DH - AJE to send and receive data to and from a JP1/DH - Server.

12. Linking JP1/PFM

Chapter 12 describes functionality that can be used, when JP1/AJS3 is linked with JP1/PFM, to examine the cause of a job delay or job failure that occurred because of a problem with system performance.

Contents

Notices 2

Summary of amendments 9

Preface 10

1 Overview 16

1.1 JP1/AJS3 functions for linking other products 17

2 Linking Mail Systems 19

2.1 Overview of linking mail systems 20

2.1.1 Overview of email reception 20

2.1.2 Behavior when receiving email 21

2.1.3 Overview of email sending 25

2.2 Setup for linking mail systems (for a Windows host when not using Outlook) 28

2.2.1 Prerequisite programs for linking mail systems 28

2.2.2 Setup for mail system linkage (when not using Outlook) 29

2.2.3 Undoing the environment setup for mail system linkage 34

2.2.4 Cautionary notes on the mail system linkage function 34

2.3 Setup for linking mail systems (for a Windows host when using Outlook) 36

2.3.1 Prerequisite programs for linking mail systems 36

2.3.2 Setup for mail system linkage (when using Outlook) 38

2.3.3 Creating profiles 39

2.3.4 Setting up the environment for the mail system linkage 41

2.3.5 Setup for operation while Outlook is running 48

2.3.6 Starting and ending the mail system linkage function 49

2.3.7 Undoing the environment setup for mail system linkage 50

2.3.8 Cautionary notes on the mail system linkage function 51

2.4 Setup for linking mail systems (for a UNIX host) 57

2.4.1 Email reception monitoring job and mail users 59

2.4.2 Setting up the environment for an email reception monitoring job 59

2.4.3 Setting up the mail delivery function 64

2.4.4 Starting and ending the mail system linkage function 64

2.4.5 Cautionary notes on the mail system linkage function 65

2.5 Mail filtering application specifications 67

2.5.1 Mail Filter Application Specifications 67

2.5.2 Specifications related to character set conversion 68

2.5.3 Specifications related to decoding MIME or other encoded email 69

2.5.4 Sample shell script for a mail filter application 69

2.5.5	Setting up a mail filter application	69
2.6	Defining email reception monitoring job	70
2.6.1	Defining an email reception monitoring job	70
2.6.2	Format of received email	71
2.6.3	List file for email reception monitoring job (Windows only)	72
2.6.4	Reception list file (UNIX only)	73
2.6.5	Cautionary note on defining an email reception monitoring job	74
2.7	Defining email sending job	75
2.7.1	Defining email sending job	75
2.7.2	Format of email to be sent	75
2.7.3	List of attached files to be sent (Windows only)	75
2.7.4	Cautionary notes on sending email (for a Windows host when not using Outlook)	76
2.7.5	Cautionary notes on sending email (for a Windows host when using Outlook)	77
2.7.6	Cautionary note on defining an email sending job	78
3	Adding Custom Jobs	79
3.1	Overview of custom jobs	80
3.1.1	Default custom jobs	80
3.1.2	Custom PC jobs and custom Unix jobs	81
3.2	Registering default custom jobs	83
3.3	Registering custom PC jobs or custom Unix jobs	84
3.3.1	Preparing the gif file for icons	84
3.4	Cautionary notes on custom jobs	86
4	Linking JP1/FTP	87
4.1	Overview of linking JP1/FTP	88
4.2	Setup for linking JP1/FTP	89
4.3	Transferring files using JP1/FTP	91
5	Linking ERP Systems	92
5.1	Overview of linking ERP systems	93
5.2	Setup for linking a SAP system or SAP BW system	94
5.3	Defining ERP linkage jobs	96
6	Linking Mainframes Using JP1/OJE	97
6.1	Overview of linking mainframes using JP1/OJE	98
6.2	Setup for executing QUEUE jobs or submit jobs	99
6.2.1	Specifying the port number	100
6.2.2	Registering user information	100
6.2.3	Registering VOS3 user information with JP1/AJS3 (JP1/OJE for VOS3 only)	101
6.3	Executing QUEUE jobs or submit jobs	102

7	Linking hp NonStop Server (Windows Only)	103
7.1	Overview of linking hp NonStop Server	104
7.2	Setup for linking hp NonStop Server	105
7.2.1	Specifying the port number	105
7.2.2	Registering user information	106
7.3	Entering jobs into hp NonStop Server	107
8	Linking JP1/Script	108
8.1	Overview of linking JP1/Script	109
8.2	Setup for linking JP1/Script	110
8.3	Executing script files	112
9	Monitoring Jobnets Using JP1/IM and JP1/IM2	113
9.1	Overview of monitoring jobnets using JP1/IM and JP1/IM2	114
9.1.1	Monitoring JP1/AJS3 by using JP1/IM	114
9.1.2	Monitoring JP1/AJS3 by using JP1/IM2	116
9.2	Setup for linking JP1/IM	121
9.2.1	Setup for displaying the job that has output the JP1 event in the Jobnet Monitor	123
9.2.2	Setup for displaying Web GUI (Job Portal) from the Event Console window of JP1/IM - View	124
9.2.3	Setup for displaying a hyperlink to Web GUI (Job Portal) in the Event Details window of JP1/IM - View	126
9.2.4	Setup for displaying a Web GUI (Job Portal) URL in emails sent by automated actions of JP1/IM	128
9.2.5	JP1 events supported by JP1/IM linkage	129
9.3	Setup for linking JP1/IM2	131
9.3.1	Setup procedure for linking JP1/IM2	131
9.3.2	Unsetup procedure for linking JP1/IM2	137
9.4	Monitoring jobnets using JP1/IM	138
9.4.1	Check JP1 events in the Event Console window	138
9.4.2	Displaying JP1/AJS3 - View from JP1/IM - View	138
9.4.3	Displaying Web GUI (Job Portal) from JP1/IM - View	139
9.5	About suggestion templates in JP1/IM2	141
9.5.1	Checking the root jobnets that are affected when an agent host stops	142
9.5.2	Checking the execution agents that are affected when an agent host stops	147
10	Automatic Distribution Using JP1/Software Distribution	153
10.1	Overview of linking JP1/Software Distribution	154
10.2	Setup for linking JP1/Software Distribution	155
10.3	Automatic distribution procedure	157
10.4	Packaging	158
10.5	Automatic distribution of packages	159
10.5.1	Automatic distribution using JP1/Software Distribution (for Windows)	159
10.5.2	Automatic distribution using JP1/Software Distribution (in UNIX)	160

11 Linking JP1/DH - AJE 162

- 11.1 Overview of linking JP1/DH - AJE 163
- 11.2 Setup for linking JP1/DH - AJE 164
- 11.3 Sending and receiving data using JP1/ DH - AJE 165

12 Linking JP1/PFM 166

- 12.1 Overview of linking JP1/PFM 167
- 12.2 Setup for linking JP1/PFM 168
- 12.3 Procedure for opening the PFM - Web Console window from the Web GUI (Job Portal) 170

Appendixes 171

- A Monitoring Jobnets Using HP NNM 172
 - A.1 Overview of monitoring 172
 - A.2 Setup for linking HP NNM (for a Windows host) 173
 - A.3 Setup for linking HP NNM (for a UNIX host) 179
 - A.4 SNMP traps 186
 - A.5 MIB objects (UNIX only) 190
- B Events Reported to HP NNM 192
- C Commands Used When Linking with HP NNM 193
 - C.1 ajsovsetup 193
 - C.2 ajsovremove 194
 - C.3 ajsovsymrem 195
 - C.4 ajsovtrap (UNIX only) 195
- D Version Revisions 198
- E Reference Material for This Manual 199
- F Glossary 200

Index 201

1

Overview

JP1/AJS3 can link other JP1 series products as well as many other products. This chapter describes an overview of linkage between JP1/AJS3 and other products.

1.1 JP1/AJS3 functions for linking other products

The table below provides an overview of programs linked with JP1/AJS3 and lists hardware and software required for the linkage.

Table 1–1: Overview of linked programs and setup required for the linkage

Linked program	Function	Hardware and software required	Chapter describing linkage
Mail system	Defines the transmission and reception of mail as jobs, and then executes them.	Mail server and mail client software	<i>Chapter 2</i>
JP1/FTP	Defines JP1/FTP processes as custom jobs, and then executes them.	JP1/FTP	<i>Chapter 4</i>
SAP system	Defines SAP system processes as custom jobs, and then executes them.	JP1/AJS3 for Enterprise Applications	<i>Chapter 5</i>
SAP BW system	Defines SAP BW system processes as custom jobs, and then executes them.	JP1/AJS3 for Enterprise Applications	<i>Chapter 5</i>
Mainframe (JP1/OJE)	Submits jobs to VOS3 or monitors jobs executed in mainframes.	JP1/OJE	<i>Chapter 6</i>
HP NonStop Server	Enters jobs into HP NonStop Server or executes jobs received from HP NonStop Server.	Job scheduler for MPP JP1 linkage option	<i>Chapter 7</i>
JP1/Script	Defines scripts created using JP1/Script as JP1/AJS3 jobs, and then executes them.	JP1/Script	<i>Chapter 8</i>
JP1/IM or JP1/IM2	Monitors the operation status of JP1/AJS3 using JP1/IM or JP1/IM2, or calls JP1/AJS3 - View from JP1/IM - View or JP1/IM2 - View to allow data to be defined or edited. If you are using JP1/IM3, the descriptions related to JP1/IM2 in this manual apply to JP1/IM3 unless otherwise specified. Differences between JP1/IM2 and JP1/IM3 are clearly specified in this manual.	JP1/IM - Manager, and JP1/IM - View JP1/IM2 - Manager, and JP1/IM2 - View JP1/IM3 - Manager, and JP1/IM3 - View	<i>Chapter 9</i>
JP1/Software Distribution	Puts jobnets and other data created using JP1/AJS3 into a package, and then distributes the package.	JP1/Software Distribution Manager and JP1/Software Distribution Client	<i>Chapter 10</i>
JP1/DH - AJE	Sends and receives data to and from JP1/DH - Server.	JP1/DH - AJE, and JP1/DH - Server	<i>Chapter 11</i>
JP1/PFM	Starts JP1/PFM - Web Console so that the user can examine the cause of a job error, or display the performance information of the manager host as a report.	JP1/PFM	<i>Chapter 12</i>
HP NNM	Monitors the operation status of JP1/AJS3 using HP NNM.	In Windows: <ul style="list-style-type: none"> • HP NNM • SNMP service In UNIX: <ul style="list-style-type: none"> • HP NNM • Job Management Partner 1/Consolidated Management 2/Extensible SNMP Agent 	<i>Appendix A</i>

Linked program	Function	Hardware and software required	Chapter describing linkage
HP NNM	Monitors the operation status of JP1/AJS3 using HP NNM.	or HP Software Extensible SNMP Agent	<i>Appendix A</i>

2

Linking Mail Systems

This chapter describes how to link with mail systems and define the reception and transmission of email in jobnets.

2.1 Overview of linking mail systems

In JP1/AJS3, you can define jobs for sending emails. You can also define monitoring jobs that detect the reception of emails under certain conditions, as an event.

By linking with a mail system, you can:

- Execute a job when an email matching specific conditions is received.
In this case, define an email reception monitoring job followed by the job you want to execute.
- Use part of the information in a received email in the succeeding job.
In this case, in the email reception monitoring job and the succeeding job, define the information passing.
- Send email to the administrator if a job ends abnormally.
In this case, define an email sending job following that job as a recovery job.

2.1.1 Overview of email reception

(1) Overview of email reception (in Windows)

In Windows, email reception monitoring jobs can only receive email via Outlook. Received messages are stored in the Inbox.

Email reception monitoring jobs reference and evaluate unread emails in the Inbox of Outlook until they find emails that meet the conditions defined for the job. For this reason, Outlook must be able to receive email from the mail server even when JP1/AJS3 is not running.

The following figure shows an overview of email reception in Windows:

Figure 2–1: Overview of email reception (in Windows)

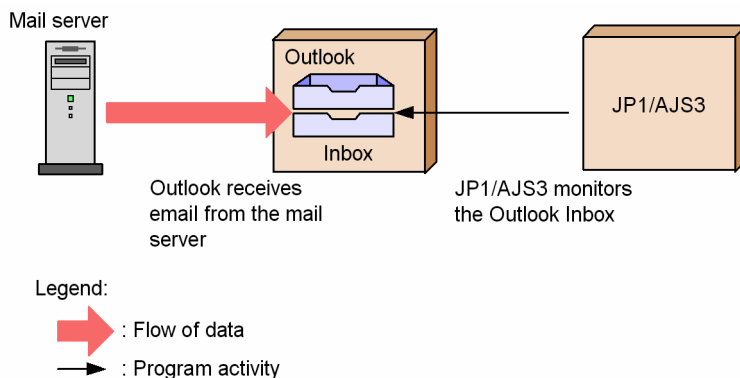

Note that if the Inbox of Outlook contains many unread emails that do not meet the defined conditions, the job might take a long time to determine applicable unread emails. You should therefore use the email system in a way that prevents many unread emails from remaining in the Inbox.

(2) Overview of email reception (in UNIX)

In UNIX, an email reception monitoring job receives email via sendmail or postfix. For this reason, sendmail or postfix must be able to receive email from the mail server even when JP1/AJS3 is not running. In a Linux environment, JP1/AJS3

can link with sendmail or postfix. In an AIX environment, JP1/AJS3 can link with sendmail. Received messages are stored in an internal email file.

The email reception monitoring job reviews the contents of the internal email file, and compares the messages in the file against the judgment conditions defined in the job.

The following figure shows an overview of email reception in UNIX:

Figure 2–2: Overview of email reception (in UNIX)

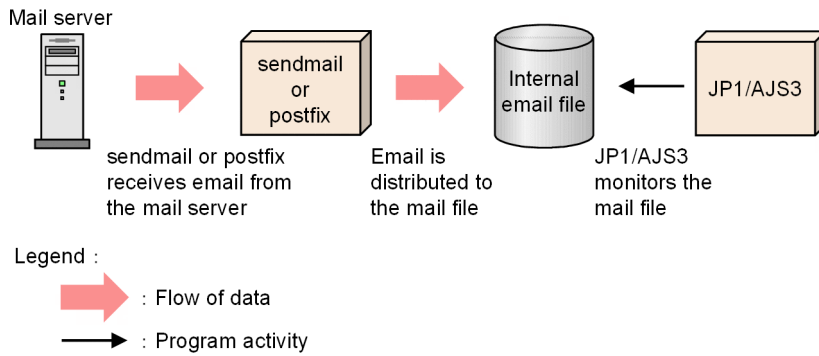

For details on the internal email file, see [2.1.2 Behavior when receiving email](#).

2.1.2 Behavior when receiving email

(1) Behavior when receiving email (for Windows)

The following figure shows the behavior of a Windows system at email reception.

Figure 2–3: Behavior at email reception (for Windows)

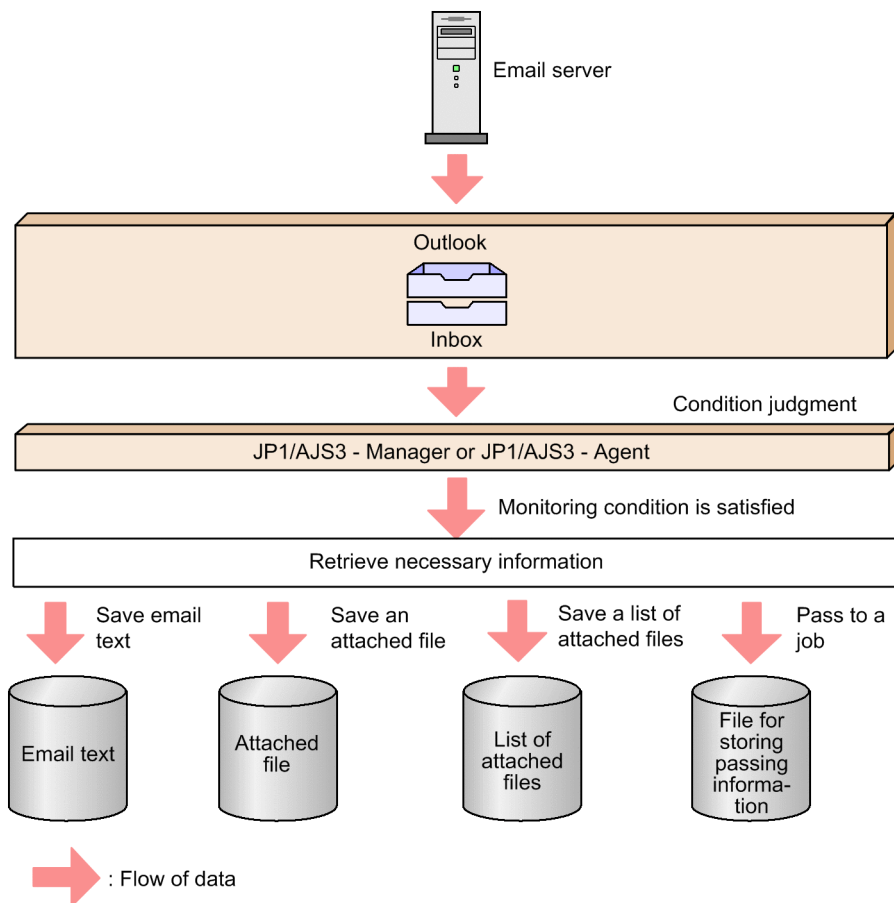

The details about the places for storing data in the above figure are as follows:

- Mail server
This stores received email.
- Inbox
This stores received email. Outlook manages this folder.
- Email text
If you specify the name of a message text file in the Detailed Definition - [Receive Mail] - [Option after Receive] dialog box used to define an email reception monitoring job, the message texts for emails that satisfy the monitoring condition are stored in the specified message text file. If there is a file with the same name in the folder, it will be overwritten.
- Attached file
If you specify the name of a folder for saving attached files in the Detailed Definition - [Receive Mail] - [Option after Receive] dialog box used to define an email reception monitoring job, the files attached to emails that satisfy the monitoring condition are stored in the specified file. The attached files are saved in the specified folder without their names being changed. If there is a file with the same name in the folder, it will be overwritten.
- List file for attached files
If you specify the name of a list file in the Detailed Definition - [Receive Mail] - [Option after Receive] dialog box used to define an email reception monitoring job, a list of the files attached to emails that satisfy the monitoring condition is stored in the specified list file. If there is a file with the same name in the folder, it will be overwritten. For details on the format of the list, see [2.6.3 List file for email reception monitoring job \(Windows only\)](#).

For details on the email text, attached files, and list file for attached files, and how to perform the **Option after receive** settings in the Detailed Definition - [Receive Mail] dialog box, see *12.4.20 Detailed Definition - [Receive Mail] dialog box* in the *JP1/Automatic Job Management System 3 Operator's Guide*. See also *12.4.21 Detailed Definition - [Receive Mail] - [Option after Receive] dialog box* in the *JP1/Automatic Job Management System 3 Operator's Guide*.

- File for storing passing information

If you specify passing information in the dialog box that opens when the **Pass Info** button in the Detailed Definition - [Receive Mail] dialog box is used to define an email reception monitoring job, the information about emails that satisfy the monitoring condition is stored when received emails are to be passed to the succeeding job.

The following information is stored in the `mail` folder in the folder specified in the `EvjobInfFile` environment setting parameter.

- Email text

Every time the email reception monitoring job in which `MLRCVBODY` is specified as passing information encounters email that satisfies the monitoring condition, a file is created (with an arbitrary name) and the email text is stored in the file.

- Attached file

Every time the email reception monitoring job in which `MLRCVATTACHFILExx` (where `xx` is a value from 01 to 20) is specified as passing information encounters email that satisfies the monitoring condition, a folder is created (with an arbitrary name) and the files attached to the email are stored in the folder (with the file name unchanged).

- List file for attached files

Every time the email reception monitoring job in which `MLRCVATTACHLIST` is specified as passing information encounters email that satisfies the monitoring condition, a file is created (with an arbitrary name) and details of the files attached to the email are stored in the file. For details on the format of the list file, see *2.6.3 List file for email reception monitoring job (Windows only)*.

If you do not specify any folder in the `EvjobInfFile` environment setting parameter, passing information is stored in the folder defined as the default folder for `EvjobInfFile`.

For details about the `EvjobInfFile` environment setting parameter, see *20.6.2(17) EvjobInfFile* in the *JP1/Automatic Job Management System 3 Configuration Guide*.

For details on the **Pass Info** button in the Detailed Definition - [Receive Mail] dialog box, see *12.4.20 Detailed Definition - [Receive Mail] dialog box* in the *JP1/Automatic Job Management System 3 Operator's Guide*.

For details about the `MLRCVBODY`, `MLRCVATTACHFILE`, and `MLRCVATTACHLIST` passing information, see *B. Information Passed by Event Jobs and Custom Event Jobs* in the *JP1/Automatic Job Management System 3 System Design (Work Tasks) Guide*.

Cautionary notes

- After email is received, the files are created for storing the email text, the attached files, the list of attached files, and passing information. However, JP1/AJS3 does not automatically delete these files. These files might use a large amount of system disk space, so delete them when they become unnecessary.
- In the environment for mail system linkage, if the action after email reception is set to `Open`, the opened email will remain in **Inbox** of Outlook. This email might use a large amount of system disk space in the mail server or in the computer where mail system linkage is performed. Activate Outlook with the profile for the mail system linkage on a regular basis to delete the opened email remaining in **Inbox**.

Note that before you delete email from **Inbox** of Outlook, you must stop the JP1/AJS3 mail monitoring process or the JP1/AJS3 Mail service.

For details on the procedures for starting and stopping the JP1/AJS3 mail monitoring process and the JP1/AJS3 Mail service, see *2.3.6 Starting and ending the mail system linkage function*.

(2) Behavior when receiving email (for UNIX)

The following figure shows the behavior of a UNIX system at email reception.

Figure 2–4: Behavior at email reception (for UNIX)

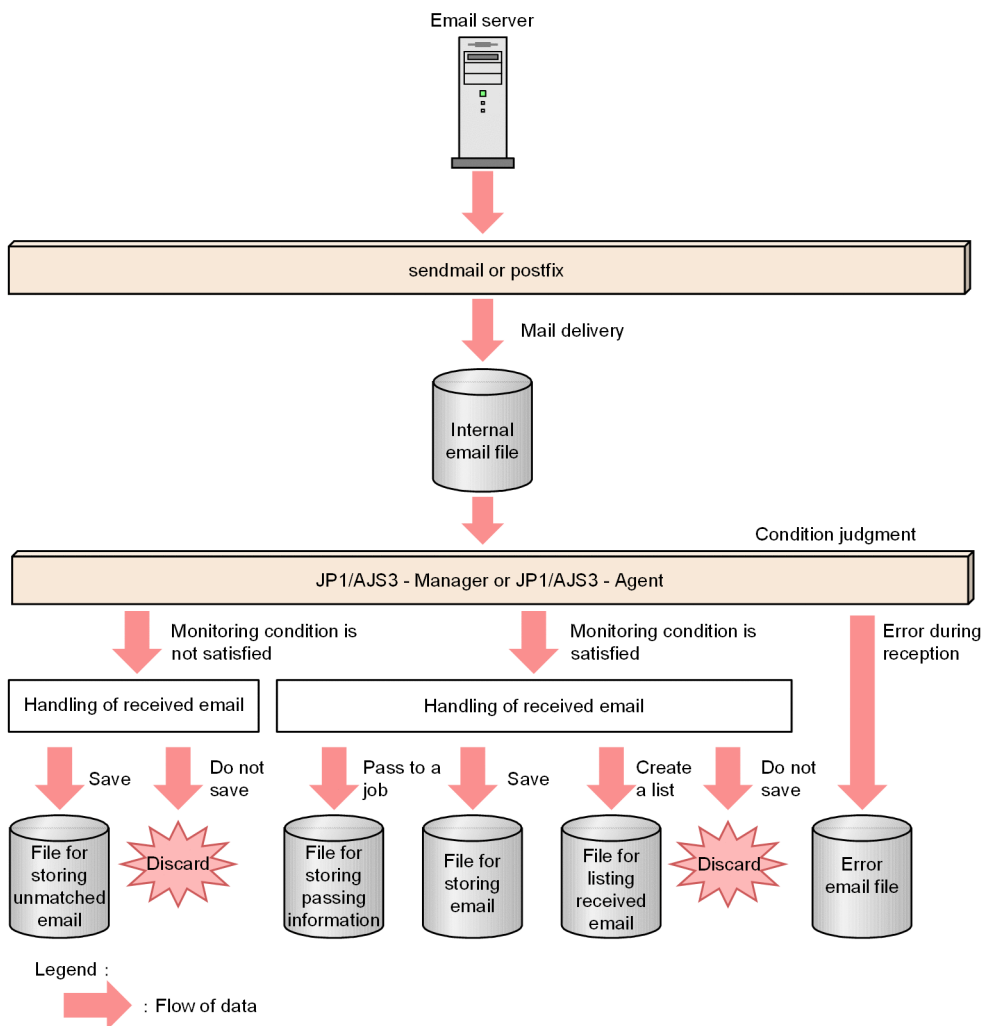

The details about the files for storing data in the above figure are as follows:

- Internal email file

This stores received email. This file can be used by the JP1/AJS3 mail linkage function. Upon reception of email, the `jpomailrcv` command (email delivery setting command) executed by the `sendmail` or the `postfix` appends the received email to the internal mail file.

The name of the internal email file is created by adding the monitoring user name to `/var/opt/jp1ajs2/tmp/mailbox/`.

- File for storing passing information

If you specify passing information in the dialog box that opens when the **Pass Info** button in the Detailed Definition - [Receive Mail] dialog box is used to define an email reception monitoring job, the information about emails that satisfy the monitoring condition is stored when received emails are to be passed to the succeeding job.

When received email is passed to the succeeding job, if the email reception monitoring job in which `MLRCVMAILBODY` is specified as passing information encounters email that satisfies the monitoring condition, a file is created and the received email is stored in the file.

A file for storing passing information is assigned a name that begins with `MLDT`. This file is stored in the `mail` directory under the event job or the custom event job information passing directory specified by the `EvjobInfFile` environment setting parameter of event/action control. The default directory is `/var/opt/jplajs2/sys/infoagt/tmp/infodir/`.

For details about the **Pass Info** button in the Detailed Definition - [Receive Mail] dialog box, see *12.4.20 Detailed Definition - [Receive Mail] dialog box* in the *JP1/Automatic Job Management System 3 Operator's Guide*.

For details about the `MLRCVMAILBODY` passing information, see *B. Information Passed by Event Jobs and Custom Event Jobs* in the *JP1/Automatic Job Management System 3 System Design (Work Tasks) Guide*.

- File for storing email

Received email is appended to this file when the email reception monitoring job instructed to save received email encounters the email that satisfies the monitoring condition.

The name of the email storage file is the value of the `MailFileName` environment setting parameter of event/action control.

- File for storing unmatched email

This stores (to the end) the email that does not satisfy the monitoring condition of the email reception monitoring job.

The name of the file for storing unmatched email is created by adding the monitoring user name to the directory specified for the `NotMatchMailDir` environment setting parameter of event/action control.

- File for listing received email

The mail header is appended to this file when the email reception monitoring job specifying the name of the file for listing received email encounters the email that satisfies the monitoring condition.

The name of the file for listing received email is specified for the email reception list of the email reception monitoring job.

- Error email file

If mail reception monitoring fails while judging email, the email is appended to this file.

The name of the error email file is `/var/opt/jplajs2/sys/infoagt/tmp/mail/errmail`.

Cautionary notes

- The email reception monitoring job creates files for storing passing information, email, unmatched email, received email listing, and error email. However, JP1/AJS3 does not automatically delete these files. These files might use a large amount of system disk space, so delete them when they become unnecessary.
- With the mail system linkage function of JP1/AJS3, email continues to accumulate in the internal email files created by the delivery function unless an email reception monitoring job is executed. The internal email files might use a large amount of system disk space, so periodically delete unnecessary internal email files.
Note that before you delete internal email files, you must stop the mail reception monitoring process and set the mail delivery function so that email is not delivered to the internal mail file.
For details on the mail delivery function, see *2.4.3 Setting up the mail delivery function*.

2.1.3 Overview of email sending

(1) Overview of email sending (in Windows)

In Windows, email sending jobs can send email either with or without using Outlook. For details on the differences between these two methods, see *4.3.4(1) Sending emails using the email sending job* in the *JP1/Automatic Job Management System 3 System Design (Configuration) Guide*.

(a) Overview of sending email without using Outlook (in Windows)

An email sending job that does not use Outlook sends data directly to the mail server.

The following figure shows an overview of sending email without using Outlook.

Figure 2–5: Overview of email sending (without using Outlook)

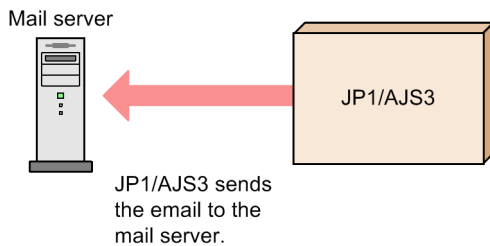

Legend:



(b) Overview of sending email using Outlook (in Windows)

An email sending job that uses Outlook places the data in the **Outbox** folder, and Outlook actually sends the email.

After email is sent, it is stored in the **Sent Items** folder in Outlook. For this reason, Outlook must be able to send email to the mail server even when JP1/AJS3 is not running.

The following figure shows an overview of sending email using Outlook.

Figure 2–6: Overview of email sending (using Outlook)

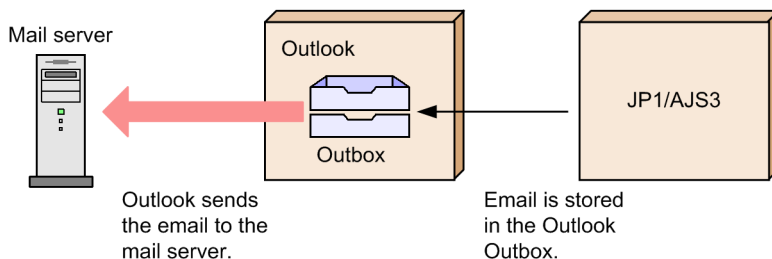

Legend:



(2) Overview of email sending (in UNIX)

In UNIX, the email sending job sends email via sendmail or postfix.

The email sending job stores email data in a temporary file, and sendmail or postfix actually sends the email. For this reason, sendmail or postfix must be able to send email to the mail server even when JP1/AJS3 is not running.

In a Linux environment, JP1/AJS3 can link with sendmail or postfix. In an AIX environment, JP1/AJS3 can link with sendmail.

The following figure shows an overview of email sending in UNIX.

Figure 2–7: Overview of email sending (in UNIX)

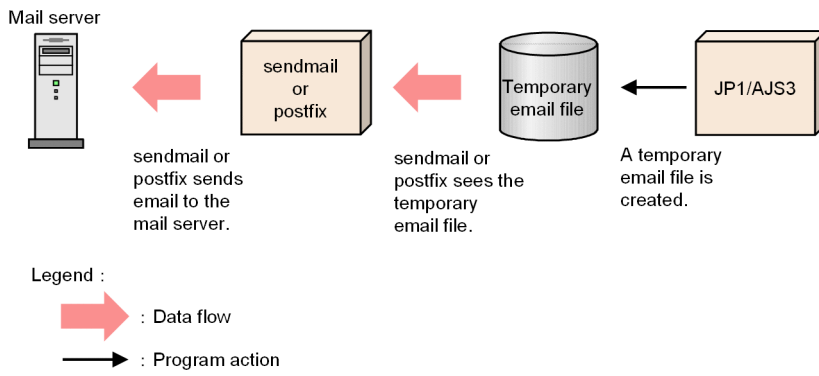

For details about sendmail and postfix, see the respective documentation for each.

2.2 Setup for linking mail systems (for a Windows host when not using Outlook)

This section describes the setup required on a Windows host when linking with a mail system that does not use Outlook.

2.2.1 Prerequisite programs for linking mail systems

The following describes the prerequisites for linked mail systems, and shows an example system configuration.

(1) Mail systems that support linkage

On a Windows host, JP1/AJS3 can link with mail systems that support the SMTP protocol. If the mail system uses POP before SMTP as the authentication method, it must also incorporate a mail server that supports POP3. Protocols that encrypt communications, such as SMTPS, are not supported.

Set up the required mail server software on the host to be linked with the mail system. This software does not need to be installed on the same host as JP1/AJS3 - Manager or JP1/AJS3 - Agent.

(2) Example system configuration

The following figure shows an example of a system configuration for linking with mail systems.

Figure 2–8: Example of a system configuration for linking with mail systems

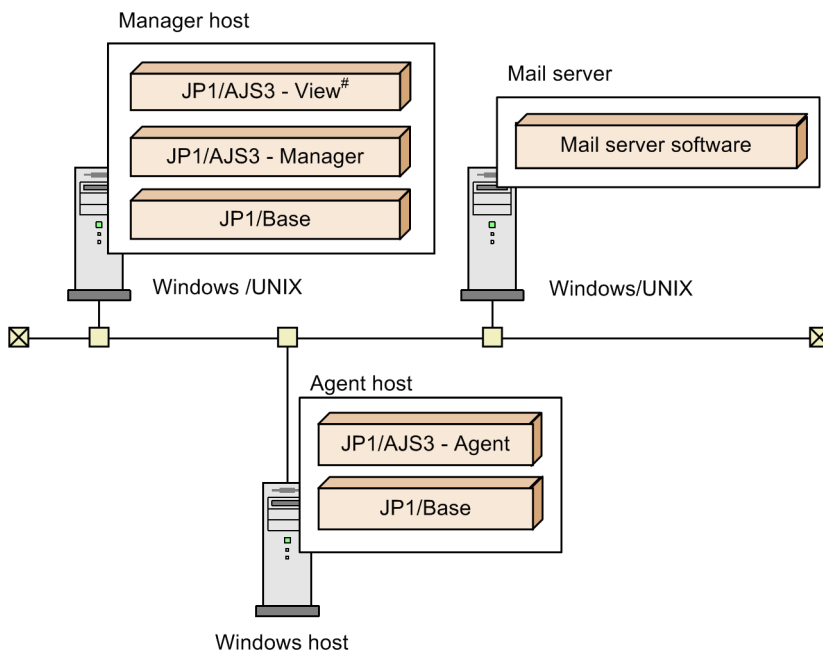

JP1/AJS3 - View is only available for Windows.

Cautionary note

The job execution host must be running version 10-00 or later of JP1/AJS3 - Manager or JP1/AJS3 - Agent.

2.2.2 Setup for mail system linkage (when not using Outlook)

When linking with a mail system to send email without Outlook, perform the setup procedure described below on hosts that will execute email sending jobs.

If you intend to use Outlook to send email, or will be using email reception monitoring jobs to receive email, see [2.3 Setup for linking mail systems \(for a Windows host when using Outlook\)](#).

Figure 2–9: Setup for linking mail systems

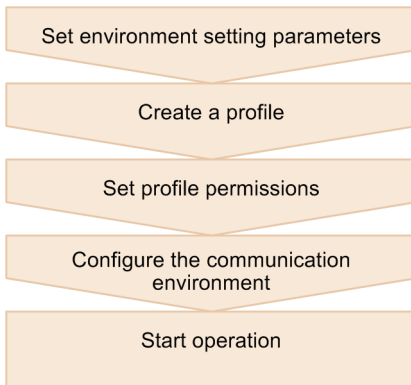

(1) Setting environment setting parameters

Execute the following command to set the environment setting parameters required for mail system linkage:

```
jajs_config -k [{{JP1_DEFAULT|logical-host-name}}\JP1AOMAGENT\mail_link]
"environment-setting-parameter-1"=definition-content-1
["environment-setting-parameter-2"=definition-content-2]
["environment-setting-parameter-3"=definition-content-3]
["environment-setting-parameter-4"=definition-content-4]
["environment-setting-parameter-5"=definition-content-5]
["environment-setting-parameter-6"=definition-content-6]
["environment-setting-parameter-7"=definition-content-7]
["environment-setting-parameter-8"=definition-content-8]
```

You do not need to restart the JP1/AJS3 service after setting these parameters.

The table below describes each of the environment setting parameters required for environment system linkage.

Table 2–1: Environment setting parameters used for mail system linkage

No.	Definition key	Environment setting parameter	Defined information
1	[{{JP1_DEFAULT logical-host-name}}\JP1AOMAGENT\mail_link]	"EmbeddedMailSender"=	Whether to run email sending jobs without Outlook
2		"ConnectTimeout"=	Connection timeout
3		"RecvTimeout"=	Timeout when waiting for a response
4		"RetryInterval"=	How long the system waits before trying again after an attempt to send an email fails
5		"RetryCount"=	How many times the system tries sending an email if previous attempts have failed

No.	Definition key	Environment setting parameter	Defined information
6	[{JP1_DEFAULT <i>logical-host-name</i> }\JP1AOMAGENT\mail_link]	"EmbeddedMailTimeout" =	Timeout for email sending jobs
7		"LogSize_EmbeddedMail" =	Size of operations logs for sending email without using Outlook
8	[JP1_DEFAULT\JP1AOMAGENT\mail_link]	"SendCutOffExcessiveData" =	Whether to send an email whose data size exceeds a prescribed number of bytes

The following describes details of the environment setting parameter definitions:

"EmbeddedMailSender"="{Y|N}"

Specify whether to send emails without using Outlook.

If you specify Y in this parameter, JP1/AJS3 will send email without using Outlook regardless of the value specified in the ExecMode parameter.

If you specify N or omit this environment setting parameter, mail system linkage will operate using Outlook.

Specifiable values

Y

Send email without using Outlook.

N

Operate mail system linkage through Outlook.

Default value

N

Recommended value

Set a value appropriate for the operating environment.

When the setting takes effect

When an email sending job is executed.

Cautionary note

Make sure that all email sending jobs have ended before you change the setting for this parameter.

"ConnectTimeout"=dword:setting-value

When sending email without using Outlook, specify how long before the connection to the mail server times out.

Specifiable values

000003E8 to 0036EE80 in hexadecimal (1,000 to 3,600,000 in decimal) (in milliseconds)

Default value

dword:00002710 (10,000 in decimal, which is 10 seconds)

Recommended value

Set a value appropriate for the operating environment.

When the setting takes effect

When an email sending job is executed.

Cautionary note

If you specify a small value for ConnectTimeout, a timeout might occur before the connection is completed, and a TCP/IP connection error might result. If the TCP/IP connection timeout period set in the OS is shorter than the period specified in this environment setting parameter, the setting in the OS overrides this environment setting parameter.

"RecvTimeout"=dword:*setting-value*

When sending email without using Outlook, specify how much time must pass before the system times out when waiting for a response from the mail server.

Specifiable values

000003E8 to 0036EE80 in hexadecimal (1,000 to 3,600,000 in decimal) (in milliseconds)

Default value

dword:00002710 (10,000 in decimal, which is 10 seconds)

Recommended value

Set a value appropriate for the operating environment.

When the setting takes effect

When an email sending job is executed.

"RetryInterval"=dword:*setting-value*

When sending email without using Outlook, specify how long (in seconds) to wait after a failed attempt to send an email before trying again.

Specifiable values

000003E8 to 0000EA60 in hexadecimal (1,000 to 60,000 in decimal) (in milliseconds)

Default value

dword:00001388 (5,000 in decimal, which is 5 seconds)

Recommended value

Set a value appropriate for the operating environment.

When the setting takes effect

When an email sending job is executed.

"RetryCount"=dword:*setting-value*

When sending email without using Outlook, specify how many times to try connecting to the mail server when previous attempts have failed.

Specifiable values

00000000 to 000005A0 in hexadecimal (0 to 1,440 in decimal) (number of times)

Default value

dword:00000000 (0 in decimal)

Recommended value

Set a value appropriate for the operating environment.

When the setting takes effect

When an email sending job is executed.

"EmbeddedMailTimeout"=dword:*setting-value*

When sending email without using Outlook, specify the total time after which an email sending job times out.

Specifiable values

00002710 to 0036EE80 in hexadecimal (10,000 to 3,600,000 in decimal) (in milliseconds)

Default value

dword:000927C0 (600,000 in decimal, which is 600 seconds)

Recommended value

Set a value appropriate for the operating environment.

When the setting takes effect

When an email sending job is executed.

Cautionary note

If the total size of the attachments for an email sending job exceeds 10 megabytes, specify a value in seconds of at least the attached file size (in megabyte) x 2.

"LogSize_EmbeddedMail"=dword:*log-size*

When sending email without using Outlook, specify the size of output log files.

Specifiable values

00080000 to 009C3C00 in hexadecimal (524,288 to 10,238,976 in decimal) (in bytes)

Default value

dword:00200000 (2,097,152 in decimal) (in bytes)

Recommended value

Set a value appropriate for the operating environment.

When the setting takes effect

When an email sending job is executed.

"SendCutOffExcessiveData"="{Y|N}"

When executing an email sending job that contains a macro variable in the message text or subject line, specify whether to send the email with excess data truncated in the following cases:

- The following data exceeds 512 bytes:
 - The message text
 - The character strings that replace the macro variables in the message text at job execution
- The following data exceeds 256 bytes:
 - The subject line
 - The character strings that replace the macro variables in the subject line at job execution

Specifiable values

Y

The email sending job sends the email with the excess data truncated.

The message KAVT3207-W is output to the integrated trace log and the Execution Result Details dialog box.

N

The email sending job does not send the mail and its status changes to *Ended abnormally*.

The message KAVT4255-E is output to the Execution Result Details dialog box.

Default value

N

Recommended value

Set a value appropriate for the operating environment.

When the setting takes effect

When an email sending job is executed.

(2) Creating profiles

To create a profile, execute the `jpomailprof` command with the `-add` option and the necessary parameters (such as the source email address and the SMTP server name) specified in the command line. You can create a maximum of 16 profiles.

The following is an example of creating a profile with the name `profile1` for a mail server that does not require authentication.

```
jpomailprof -add -n profile1 -m mail@mail.com -s smtp.com
```

To display a list of profiles or check the contents of a profile, execute the `jpomailprof` command with the `-show` option specified.

For details about the `jpomailprof` command, see *jpomailprof (Windows only)* in *3. Commands Used for Normal Operations* in the manual *JP1/Automatic Job Management System 3 Command Reference*.

In a cluster environment, create profiles on the executing host only, while the shared disk is accessible. There is no need to create profiles on the standby host.

(3) Setting profile permissions

When you execute the `jpomailprof` command, JP1/AJS3 creates the following folder in which to store profiles and log files.

```
profile-storage-folder\sys\prf
```

In the command line above, replace *profile-storage-folder* with the value specified in the `WaitInfFileOutDir` environment setting parameter in the definition key `[{JP1_DEFAULT|logical-host-name}\JP1AOMAGENT]`. For details on the `WaitInfFileOutDir` parameter, see *20.6.2(16) WaitInfFileOutDir (for agent processes)* in the *JP1/Automatic Job Management System 3 Configuration Guide*.

All users will initially have read, write, and delete permissions for the folder created by the `jpomailprof` command and its contents. If allowing all users to have read and write permissions is a problem in your environment, you can change the permissions for the folder and files provided that the following criteria are met.

Table 2–2: Permissions required for the profile storage folder

Folder or file	Permission required by	Required permissions
<ul style="list-style-type: none"> <i>prf_path</i> folder Files in the <i>prf_path</i> folder 	User with Administrators permission	<ul style="list-style-type: none"> Read Write Delete
<ul style="list-style-type: none"> <i>prf_path\profile-name</i> folder Folders and files in the <i>prf_path\profile-name</i> folder 	<ul style="list-style-type: none"> User with Administrators permission OS user mapped to the JP1 user who executes email sending jobs that specify the profile with the same name as the <i>profile-name</i> folder. 	<ul style="list-style-type: none"> Read Write Delete

Legend:

prf_path: The folder containing the profiles.

Cautionary note

In a cluster environment, these permissions must be assigned to users on the standby host as well as the executing host.

(4) Setting up the communication environment

The following describes the setup required to send email without using Outlook.

(a) Name resolution

Configure the `hosts` file or DNS so that the name of the mail server can be resolved.

If you send email without using Outlook, JP1/AJS3 will not reference the `jp1hosts` or `jp1hosts2` information when performing name resolution.

If the host name resolves to multiple IP addresses, JP1/AJS3 will attempt to access each IP address in the order in which they were acquired until a connection is established.

(b) Firewall

Because email sending jobs communicate directly with the mail server, the firewall must be configured to allow communication between the execution host and the mail server.

As shown in the table below, the default port numbers and connection-target mail servers differ according to the used authentication method.

Table 2–3: Connection-target port numbers

No.	Authentication method	Port number	Target mail server
1	None	25/tcp	SMTP server
2	POP before SMTP	110/tcp	POP3 server
		25/tcp	SMTP server
3	SMTP-AUTH PLAIN or SMTP-AUTH LOGIN	587/tcp	SMTP server

For details on using JP1/AJS3 behind a firewall, see *2.3.2 Firewall and communication basics* in the *JP1/Automatic Job Management System 3 System Design (Configuration) Guide*.

2.2.3 Undoing the environment setup for mail system linkage

To undo the settings associated with the mail system linkage function:

1. Set the parameter that disables the mail system linkage function.

Execute the following command:

```
jajs_config -k [{JP1_DEFAULT|logical-host-name}\JP1AOMAGENT\mail_link] "EmbeddedMailSender"="N"
```

You do not need to restart the JP1/AJS3 service after setting the `EmbeddedMailSender` environment setting parameter.

2.2.4 Cautionary notes on the mail system linkage function

This subsection gives some cautionary notes on the mail system linkage function.

(1) Backing up and restoring profiles

You can back up and restore profiles even while the JP1/AJS3 service is running. However, if you attempt to back up or restore a profile while an email sending job or the `jpomailprof` command is being executed, the backup or restoration process might end with an error, or the email sending job or `jpomailprof` command might terminate abnormally.

In a cluster environment, make sure that the shared disk is accessible while you back up or restore profiles.

After restoring a profile, set the folder and file permissions as necessary.

For details on backup and recovery in a JP1/AJS3 system, see 2. *Backup and Recovery* in the *JP1/Automatic Job Management System 3 Administration Guide*. For details on setting permissions, see 2.2.2(3) *Setting profile permissions*.

(2) Action to take after changing the environment for mail system linkage

The following describes the action to take when changes are made to the environment in which mail system linkage is operating.

- If the name of the SMTP server is changed:
Change the SMTP server name in the profile.
- If the IP address of the SMTP server is changed:
Change the IP address specified for the SMTP server name in the profile. This step is not necessary if you specified the SMTP server name in the `-s` option of the `jpomailprof` command.
- If the name of the POP3 server is changed:
Change the POP3 server name in the profile.
- If the IP address of the POP3 server is changed:
Change the IP address specified for the POP3 server name in the profile. This step is not necessary if you specified the POP3 server name in the `-r` option of the `jpomailprof` command.
- If the value of the `WaitInFileOutDir` parameter in the definition key [`{JP1_DEFAULT|logical-host-name}\JP1AOMAGENT`] is changed:
Create the profile again.

(3) Action to take after changing how emails are sent

If you change an email sending job that does not use Outlook into a job that uses Outlook, perform the setup needed for the job to send email using Outlook. If you give the new profile the same name as the profile the job had been using, you can do so without changing the job definition.

For details on the setup needed to send emails using Outlook, see 2.3 *Setup for linking mail systems (for a Windows host when using Outlook)*.

2.3 Setup for linking mail systems (for a Windows host when using Outlook)

This section describes the setup required on a Windows host when linking with a mail system that uses Outlook.

2.3.1 Prerequisite programs for linking mail systems

This subsection describes the programs and setup prerequisites for the mail system linkage function that uses Outlook in Windows.

Outlook is a prerequisite program for mail system linkage function, and must be installed on the same host as JP1/AJS3 - Manager or JP1/AJS3 - Agent.

Outlook conforms to the MAPI standard developed by Microsoft, and for this reason Outlook-based mail system linkage function is implemented using MAPI.

(1) Mail systems that support linkage

On a Windows host, the mail system linkage function supports linkage with the following mail systems:

- Exchange Server
- SMTP/POP3

Set up the mail server software of your choice on the host where mail system linkage will operate. The software does not need to be installed on the same host as JP1/AJS3 - Manager or JP1/AJS3 - Agent. Exchange Online is not supported.

You can use the mail system linkage function from a service or from the desktop. You must select one or the other to use the mail system linkage function.

The following table shows the correspondence between supported mail systems and the mail system linkage function.

Table 2–4: Supported mail systems and options of the mail system linkage function

Linked mail system	Mail system linkage function	
	Desktop-based	Service-based
Exchange Server	Y	Y
SMTP/POP3 [#]	Y	N
Exchange Online	N	N

Legend:

Y: Linkage is supported.

N: Linkage is not supported.

#

Includes mail servers that support the SMTP/POP3 protocol (such as Lotus Notes Domino).

When you use the mail system linkage function from a service, the JP1/AJS3 Mail service must be running when you execute an email sending job or email reception monitoring job. When using the function from the desktop, the JP1/AJS3 email monitoring process must be running when you execute the job.

The option you select determines whether you need to log on to Windows to use the mail system linkage function. When you use the mail system linkage function with a service, you do not need to log on to Windows provided that the JP1/AJS3 Mail service is running. If you use the function on the desktop, you cannot start the JP1/AJS3 mail monitoring process without first logging on to Windows.

For details on how to specify whether mail linkage takes place from a service or the desktop, see [2.3.4 Setting up the environment for the mail system linkage](#). For details on how to start the JP1/AJS3 mail monitoring process or the JP1/AJS3 Mail service, see [2.3.6 Starting and ending the mail system linkage function](#).

Support for mail system linkage depends on the operating system. The software prerequisites also differ between operating systems. The following table describes the support for mail system linkage by operating system, and the prerequisite programs for the mail system linkage function in each environment. Office 365 is not supported.

Table 2–5: Support and prerequisite programs for mail system linkage by operating system

OS	Prerequisite program					
	Outlook 2021 (64-bit)	Outlook 2021 (32-bit)	Outlook 2019 (64-bit)	Outlook 2019 (32-bit)	Outlook 2016 (64-bit)	Outlook 2016 (32-bit)
Windows Server 2022	N	Y	N	Y	N	N
Windows Server 2019	N	Y	N	Y	N	N
Windows Server 2016	N	N	N	N	N	Y

Legend:

Y: Supports mail system linkage.

N: Does not support mail system linkage.

In the following operating systems, you can use the mail system linkage function by running Outlook 2021 (32-bit), Outlook 2019 (32-bit), or Outlook 2016 (32-bit) in a WOW64 environment:

- Windows Server 2022
- Windows Server 2019
- Windows Server 2016

The mail system linkage function cannot link to the Outlook 2021 (64-bit), Outlook 2019 (64-bit), or Outlook 2016 (64-bit) in any operating system.

The versions of Outlook you can use with the mail system linkage function depends on the environment (Windows and JP1/AJS3 version) on the host that executes the email sending job or email reception monitoring job. When linking with a mail system, check which versions of Outlook are supported by reading the *Release Notes* provided with the version of JP1/AJS3 installed on the host that will execute the email sending job or email reception monitoring job.

(2) Example system configuration

The following figure shows an example of a system configuration for linking with mail systems.

Figure 2–10: Example of a system configuration for linking with mail systems

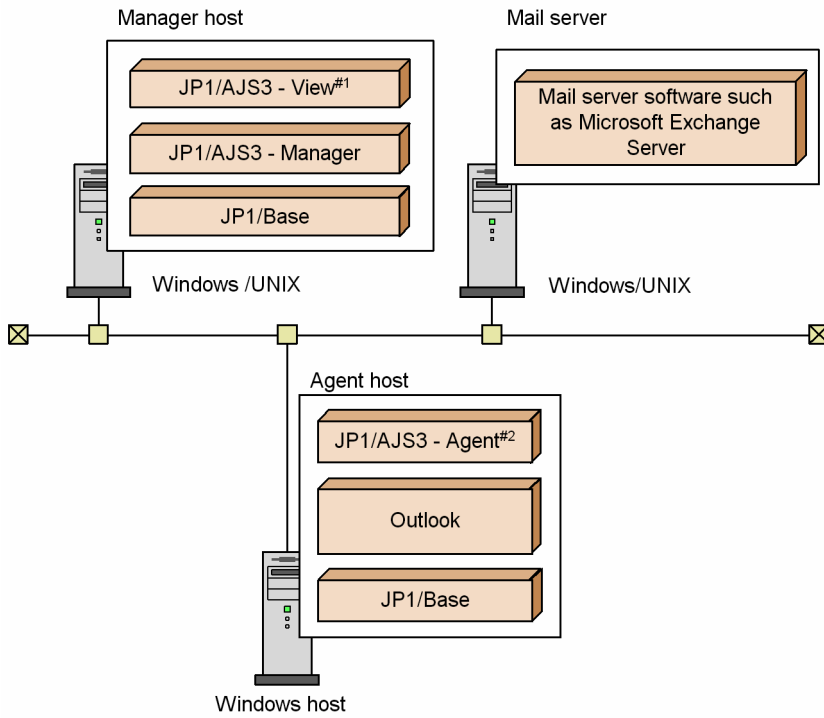

#1

JP1/AJS3 - View is only available for Windows.

#2

JP1/AJS3 - Agent on the agent host executes email sending jobs and email reception monitoring jobs requested from JP1/AJS3 - Manager on the manager host.

2.3.2 Setup for mail system linkage (when using Outlook)

When linking with a mail system, perform the setup procedure shown in the figure below on hosts that will execute email sending jobs or email reception monitoring jobs.

Figure 2–11: Setup procedure for linking mail systems

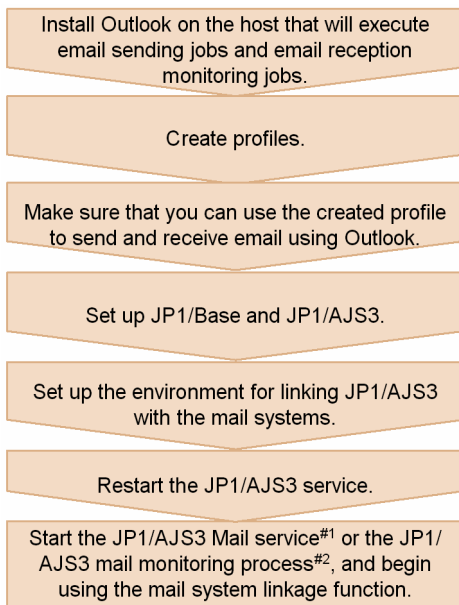

#1
When linked through a service

#2
When linked from the desktop

2.3.3 Creating profiles

JP1/AJS3 logs in to linked mail systems via Outlook. For this reason, you need to create a profile in advance.

To create a profile, log on to Windows using either of the following accounts:

When using a service to link with the mail system

The account set for (operated by) the JP1/AJS3 Mail service

When linking with the mail system from the desktop

The account for logging into Windows

In addition, when creating a profile, specify a unique profile name. For details, see [2.3.4 Setting up the environment for the mail system linkage](#).

(1) Creating a profile and performing checks after creating the profile

1. In the Windows **Control Panel**, choose the **Mail** icon. Alternatively, from the Windows Start menu, choose **Run**, enter `control "Microsoft-Office-installation-folder\mlcfg32.cpl"` in the dialog box that opens, and then click **OK**.

The Mail dialog box appears.

The Mail dialog box does not appear if a profile has already been created. In that case, open the Mail Setting - *profile-name* dialog box and then click **Profiles** to display the Mail dialog box.

2. In the Mail dialog box, click **Add** to display the Email Account dialog box. Follow the instructions in the dialog box to create a profile.

In the screen for specifying the server type, select the mail system you want to use.

3. Make sure that you can start Outlook.

4. Set Outlook as the default email program for the system.

For details on how to do so, see the Outlook Help.

An attempt to execute the email sending job or email reception monitoring job before this setting has been specified fails, causing Outlook to display the following message in a dialog box: Please run Microsoft Outlook and set it as the default mail client.

5. Make sure that you can send and receive emails by using Outlook.

Without starting JP1/AJS3, verify that both the email sending processing and the email reception processing in Outlook work correctly. When making the verification, make sure that the following conditions are the same as the conditions for the mail system linkage function used in JP1/AJS3:

- Computer used
- Profile used
- Email recipient
- Sender, subject, and body of the email
- Account that Outlook uses to log on to the mail system

Note that you must verify that both email sending and reception work correctly even if you execute only the email sending job or the email reception monitoring job.

If Outlook is being used offline, open the **File** menu of Outlook, and then switch the Outlook mode from offline to online.

When in offline mode, Outlook is not connected to any mail server. As a result, the emails sent by the email sending job might remain in the Outbox of Outlook or the running email reception monitoring job might be unable to detect emails that are being received.

6. Make sure that the following types of dialog box do not appear when you start Outlook or use Outlook to send and receive email:

- Dialog boxes that prompt the user to enter a server name, user name, or password.
- Dialog boxes that require some kind of action by the user such as clicking a button.

Automatic operation that involves mail system linkage is not possible in an environment where such a dialog box is displayed. If this situation arises, review and correct the profile settings so that the dialog box is no longer displayed.

(2) Using the mail system linkage function with a different user account

Assume that you need to send email from another user's account while the administrator is absent. In order to allow different users to use the desktop-based mail system linkage function, create a profile having the same name and contents for each user account. This enables you to modify the sender of mail without modifying job definitions or the current profile.

Suppose, for example, a user named `mail master` usually sends mail using an email sending job. Usually, the `mail master` logs on to Windows to operate the JP1/AJS3 mail monitoring process. You can create a profile with the same name as the `mail master` for the administrator account, so that the administrator can take over when the `mail master` is absent. The administrator can then log on to Windows and read that profile to send mail from the administrator account. However, we do not recommend you use this method in a system where email sending jobs and email reception monitoring jobs are used in the same environment, because an email that an email sending job sends from a different account will not match the sender specified in the conditions for the email reception monitoring job.

2.3.4 Setting up the environment for the mail system linkage

This subsection describes the environment setup procedure in JP1/AJS3 and items to be specified for linking a mail system on a Windows host.

(1) Procedure for environment setup

To set up the environment:

1. Register the mail system linkage function in Windows.

For details on how to register the mail system linkage function, see [\(2\) Registering the mail system linkage function](#).

2. Set the environment setting parameters required by the mail system linkage function.

For details on setting these parameters, see [\(3\) Setting environment setting parameters for the mail system linkage function](#).

For details on the environment setting parameters that the mail system linkage function uses, see [\(4\) Environment setting parameters used by the mail system linkage function](#).

3. Set up Windows automatic logon.

If you are using desktop-based mail system linkage, set up Windows automatic logon as required. The user account specified in the Windows automatic logon settings will be used to execute the JP1/AJS3 mail monitoring process. At this stage, specify the user account that you used to create the profile. If you specify any other user account, the system cannot reference the profile when starting the JP1/AJS3 mail monitoring process, and cannot connect to the mail server. This prevents the JP1/AJS3 mail monitoring process from starting.

For details on how to set up Windows automatic logon, see the documentation provided by Microsoft.

4. Restart the JP1/AJS3 service and the JP1/AJS3 mail monitoring process or JP1/AJS3 Mail service.

After restarting the JP1/AJS3 service, restart the JP1/AJS3 mail monitoring process if implementing mail system linkage from the desktop, and the JP1/AJS3 Mail service if implementing mail system linkage with a service. The environment is set up with the defined information, and you can now use the mail system linkage function.

Also restart the process or service described above not only when mail system linkage is initially set up, but also after you have changed the settings of the environment setting parameters for mail system linkage. Restarting the process or service enables you to use mail system linkage with the new parameter settings.

For details when mail system linkage is used within the service, see [2.3.8\(15\) Notes on using mail system linkage in a service](#).

(2) Registering the mail system linkage function

The following describes how to register the mail system linkage function in Windows.

- When using the mail system linkage function from the desktop

The following shows the procedure for using the mail system linkage function from the desktop. Note that each user who has created a profile used for mail system linkage must log on separately to perform the following procedure:

1. Create a shortcut file for `JP1/AJS3-installation-folder\bin\jpomldsk.exe`.
2. Rename the shortcut file Mail Monitoring Process.
3. Store the shortcut file.

Store the created shortcut file in the following folder:

`%USERPROFILE%`

`\AppData\Roaming\Microsoft\Windows\Start Menu\Programs\StartUp`

The default of the `%USERPROFILE%` value is `system-drive\Users\user-name`.

If you might terminate and then restart the mail monitoring process while you are logged on, use the following procedure to make it possible to start the process by opening the Windows Start menu, and then selecting **Mail Monitoring Process**:

1. Open the Windows Start screen.
2. If the Start screen does not include a shortcut to the mail monitoring process, create a shortcut, and then pin the shortcut you created to the Start screen or task bar.

Supplementary note

If you are no longer using the mail system linkage function on the desktop or if you have uninstalled JP1/AJS3, delete the folder and the shortcut file.

- When using the mail system linkage function from a service

Execute the following command to register the JP1/AJS3 Mail service:

```
sc create JP1_AJS2_MAIL binPath= "\"JP1/AJS3-installation-folder\bin\jpoml
srv.exe\" type= own start= demand error= normal obj= LocalSystem DisplayN
ame= "JP1/AJS3 Mail"
```

For example, if JP1/AJS3 is installed in C:\Program Files (x86)\HITACHI\JP1AJS2, execute the command as follows:

```
sc create JP1_AJS2_MAIL binPath= "\"C:\Program Files (x86)\HITACHI\JP1AJS2
\bin\jpomlsrv.exe\" type= own start= demand error= normal obj= LocalSyste
m DisplayName= "JP1/AJS3 Mail"
```

Because the JP1/AJS3 Mail service must be run from the account that you used to log on to Windows when you created the profile used by the mail system linkage function, ensure that this user account is set in the properties window of the JP1/AJS3 Mail service.

The `sc` command is provided by Microsoft. For details on this command, see the Microsoft documentation.

Also, when you execute the `sc` command, specify the settings (other than the JP1/AJS3 installation folder name) as shown in the above example. If you change the settings other than the JP1/AJS3 installation folder name, you might not be able to use the mail system linkage function.

(3) Setting environment setting parameters for the mail system linkage function

Execute the following command:

```
jajs_config -k definition-key-name "environment-setting-parameter-1"=definit
ion-content-1
["environment-setting-parameter-2"=definition-content-2]
["environment-setting-parameter-3"=definition-content-3]
["environment-setting-parameter-4"=definition-content-4]
["environment-setting-parameter-5"=definition-content-5]
["environment-setting-parameter-6"=definition-content-6]
["environment-setting-parameter-7"=definition-content-7]
["environment-setting-parameter-8"=definition-content-8]
["environment-setting-parameter-9"=definition-content-9]
["environment-setting-parameter-10"=definition-content-10]
["environment-setting-parameter-11"=definition-content-11]
```

For details, see [\(4\) Environment setting parameters used by the mail system linkage function](#).

(4) Environment setting parameters used by the mail system linkage function

The table below describes the environment setting parameters for the mail system linkage function that are related to event and action control. For details on the environment setting parameters that relate to event/action control in general, see *20.6 Setting up the event/action control environment* in the *JP1/Automatic Job Management System 3 Configuration Guide*.

Parameters not described in the manual are intended for maintenance purposes. Do not change these values.

Table 2–6: Environment setting parameters used for mail system linkage

No.	Definition key	Environment setting parameter	Defined information
1	[JP1_DEFAULT\JP1AOMAGE NT\mail_link]	"ExecMode"=	Whether to use the mail system linkage function
2		"ProfileName1"=	The name of the profile used to log in to the mail system
3		"ProfileName2"=	
4		"ProfileName3"=	
5		"ProfileName4"=	
6		"AfterReceiveMail"=	
7		"NextAddress"=	The type of information set as the MLRCVADDRESS passing information of the email reception monitoring job
8		"ReceiveIntervalC"=	Interval at which email reception is monitored
9		"ImmediateSendRecv"=	Whether to send and receive email immediately
10		"SendCutOffExcessiveData"=	Whether to send email if the data size exceeds the predefined number of bytes
11		"WrapTextWithOutlookOption"=	Whether to wrap message text according to the Outlook options

The following describes details of the environment setting parameter definitions:

(a) ExecMode

Specify whether to enable or disable the mail system linkage function. The default is N.

Format

"ExecMode"="{ S | D | N }"

Specifiable values

- S
Use the mail system linkage function with a service.
- D
Use the mail system linkage function from the desktop.
- N
Do not use the mail system linkage function.

Default value

N

Recommended value

Set a value appropriate for the operating environment.

When the setting takes effect

The next time the JP1/AJS3 service is started, or the next time the JP1/AJS3 mail monitoring process or the JP1/AJS3 Mail service is started.

(b) ProfileName1

Specify the name of the profile to use to log in to the mail system.

You can specify a maximum of four profiles using the parameters `ProfileName1` to `ProfileName4`.

Specify a profile name that is different from the environment setting parameters `ProfileName2` to 4. If profile names are not unique, you might not be able to use the mail system linkage function.

Format

```
"ProfileName1"="profile-name"
```

Specifiable values

A character string of no more than 256 bytes

Multi-byte characters are specifiable.

Default value

Blank

Recommended value

Set a value appropriate for the operating environment.

When the setting takes effect

The next time the JP1/AJS3 service is started, or the next time the JP1/AJS3 mail monitoring process or the JP1/AJS3 Mail service is started.

(c) ProfileName2

Specify a profile name that is different from the environment setting parameters `ProfileName1`, and 3 to 4. If profile names are not unique, you might not be able to use the mail system linkage function.

Format

```
"ProfileName2"="profile-name"
```

(d) ProfileName3

Specify a profile name that is different from the environment setting parameters `ProfileName1` to 2, and 4. If profile names are not unique, you might not be able to use the mail system linkage function.

Format

```
"ProfileName3"="profile-name"
```

(e) ProfileName4

Specify a profile name that is different from the environment setting parameters `ProfileName1` to 3. If profile names are not unique, you might not be able to use the mail system linkage function.

Format

```
"ProfileName4"="profile-name"
```

(f) AfterReceiveMail

Determine how to treat received mail that matches the monitoring conditions after the email reception monitoring job has terminated.

Format

```
"AfterReceiveMail"="{O|D}"
```

Specifiable values

- O
Mail that matches the monitoring conditions is marked as read.
- D
Mail that matches the monitoring conditions is deleted.

Default value

O

Recommended value

Set a value appropriate for the operating environment.

When the setting takes effect

The next time the JP1/AJS3 service is started, or the next time the JP1/AJS3 mail monitoring process is started.

(g) NextAddress

Select the type of information to be set in the passing information MLRCVADDRESS of the email reception monitoring job.

- MLRCVADDRESS is information representing the sender specified in the email reception monitoring job.
- This setting affects all email reception monitoring jobs that run on the host where the setting has been made.

For details about MLRCVADDRESS, see *B. Information Passed by Event Jobs and Custom Event Jobs* in the *JP1/Automatic Job Management System 3 System Design (Work Tasks) Guide*.

Format

```
"NextAddress"="{Address|Nickname}"
```

Specifiable values

Address

Sets the mail address as passing information.

If the Internet Mail profile is used, the succeeding email sending job can use the mail address as the destination.

Nickname

Sets the display name (nickname) as passing information.

If Exchange Server is specified in the profile as the connection destination, the succeeding email sending job can use the nickname as the destination.

If the connection destination specified in the profile is not Exchange Server, the succeeding email sending job inherits a null value.

Default value

Address

Recommended value

Set a value appropriate for the operating environment.

When the setting takes effect

The next time the JP1/AJS3 service is started, or the next time the JP1/AJS3 mail monitoring process or the JP1/AJS3 Mail service is started.

(h) ReceiveIntervalC

Specify the time interval for checking whether email has been received, as a hexadecimal value. Specify a value from 1 to 5A0 (in minutes).

Format

```
"ReceiveIntervalC"=dword:time-interval
```

Specifiable values

1 to 5A0 in hexadecimal (1 to 1,440 in decimal) (in minutes)

Default value

A (10 in decimal) (in minutes)

Recommended value

Set a value appropriate for the operating environment.

When the setting takes effect

The next time the JP1/AJS3 service is started, or the next time the JP1/AJS3 mail monitoring process or the JP1/AJS3 Mail service is started.

(i) ImmediateSendRecv

Specify whether to send and receive mail immediately when using the mail system linkage function on the desktop.

Format

```
"ImmediateSendRecv"="{ Y | N } "
```

Specifiable values

Y

When email sending and email reception monitoring jobs are running as JP1/AJS3 jobs, the **Send/Receive** button of Outlook can be used from JP1/AJS3 to immediately send and receive emails.

N

When email sending and email reception monitoring jobs are running as JP1/AJS3 jobs, Outlook is started from JP1/AJS3 and sending and receiving emails becomes the responsibility of Outlook.

Outlook sends and receives emails at the send and receive intervals defined as options in Outlook.

For details about the Outlook option settings, see the Help in Outlook.

After the jobs end, Outlook remains active and the Outlook icon remains on the taskbar.

Note that if Outlook is already running when a job starts, Outlook is not started a second time when the job starts.

Default value

Y

Recommended value

Set a value appropriate for the operating environment.

When the setting takes effect

The next time the JP1/AJS3 service is started, or the next time the JP1/AJS3 mail monitoring process is started.

For details about this parameter, see *2.3.5 Setup for operation while Outlook is running*.

(j) SendCutoffExcessiveData

Specify whether to truncate mail data when the email sending job sends mail for which macro variables are defined in the body and subject line in the following cases:

- When the following data length exceeds 512 bytes:
The length of the text in the body + the length of the character strings that replace the macro variables in the body during job execution
- When the following data length exceeds 256 bytes:
The length of the text in the subject line + the length of the character strings that replace the macro variables in the subject line during job execution

Format

```
"SendCutoffExcessiveData"="{Y|N}"
```

Specifiable values

Y

The email sending job sends the mail minus the excess data.

The KAVT3207-W message, which reports that data has been truncated, is output to the integrated trace log and Execution Result Details dialog box.

N

The email sending job does not send the mail and its status changes to Ended abnormally.

The KAVT4255 message, which reports an invalid data length, is output to Execution Result Details dialog box.

Default value

N

Recommended value

Set a value appropriate for the operating environment.

When the setting takes effect

The next time the JP1/AJS3 service is started, or the next time the JP1/AJS3 mail monitoring process or the JP1/AJS3 Mail service is started.

(k) WrapTextWithOutlookOption

Specify whether to wrap text as defined in the Outlook options when you use mail system linkage from the desktop and connect to the mail server using standard Internet email protocols (SMTP/POP3).

Format

```
"WrapTextWithOutlookOption"="{Y|N}"
```

Specifiable values

Y

The message text of an email sending job is wrapped after the number of characters specified in the **Automatically wrap text at** field in the Internet Format dialog box, accessed from the Mail Format page of the Outlook options.

N

The message text of an email sending job is wrapped after 72 bytes.

Default value

N

Recommended value

Set a value appropriate for the operating environment.

When the setting takes effect

The next time the JP1/AJS3 service is started, or the next time the JP1/AJS3 mail monitoring process is started.

Cautionary notes

- Text wrapping is applied to incoming email.
- In the following circumstances, text wrapping is not applied regardless of the value specified in this parameter:
 - You use the mail system linkage function from a service
 - You connect to a mail server running Exchange Server

2.3.5 Setup for operation while Outlook is running

If the mail system linkage function is used on the desktop, the email sending job or email reception monitoring job program starts Outlook and uses the **Send/Receive** button to immediately send or receive emails.

If Outlook starts according to specification while an email sending or email reception monitoring job is running, the program for the job might be unable to operate Outlook. In this case, the job status might change to *Ended abnormally*, or some other unexpected problem might occur. If you need to start Outlook while an email sending or email reception monitoring job is running, specify the environment setting parameter below so that the job will not immediately send or receive emails.

The following environment setting parameter determines whether email is sent and received immediately:

Definition key

[JP1_DEFAULT\JP1AOMAGENT\mail_link]

Environment setting parameter

"ImmediateSendRecv"="{Y|N}"

Specifies whether to immediately send and receive email.

The default is Y.

Y

When email sending and email reception monitoring jobs are running as JP1/AJS3 jobs, the **Send/Receive** button of Outlook can be used from JP1/AJS3 to immediately send and receive emails.

N

When email sending and email reception monitoring jobs are running as JP1/AJS3 jobs, Outlook is started from JP1/AJS3 and sending and receiving emails becomes the responsibility of Outlook.

Outlook sends and receives emails at the send and receive intervals defined as options in Outlook.

For details on setting the Outlook options, see Outlook Help.

After the jobs end, Outlook remains active and the Outlook icon remains on the taskbar.

Note that if Outlook is already running when a job starts, Outlook is not started a second time when the job starts.

Setting procedure:

To set the environment setting parameter:

1. Execute the following command:

```
jajs_config -k
[JP1_DEFAULT\JP1AOMAGENT\mail_link] "ImmediateSendRecv"="N"

or

jajs_config -k
[JP1_DEFAULT\JP1AOMAGENT\mail_link] "ImmediateSendRecv"="Y"
```

2.3.6 Starting and ending the mail system linkage function

This subsection describes the procedures for starting up and ending the mail system linkage function. The subsection consists of two parts. One part is dedicated to use of the function on the desktop, and the other part, to use of the function with a service.

(1) Procedures for starting and ending the mail system linkage function used on the desktop

To use the mail system linkage function on the desktop, you must start the JP1/AJS3 mail monitoring process.

If a shortcut file for the JP1/AJS3 mail monitoring process is registered in the startup group in Windows, the JP1/AJS3 mail monitoring process starts automatically when you log on to Windows.

If you need to start the JP1/AJS3 mail monitoring process after you have manually stopped it, click or double-click one of the following shortcuts to the JP1/AJS3 mail monitoring process:

- The shortcut file registered in the startup group of Windows
- The shortcut file registered in **JP1_Automatic Job Management System 3 - Manager** or **JP1_Automatic Job Management System 3 - Agent**, which appears when you open the Windows Start menu

For details about how to register the shortcut file for the JP1/AJS3 mail monitoring process in the startup group and on the Windows Start menu, see *When using the mail system linkage function from the desktop in 2.3.4(2) Registering the mail system linkage function*.

To stop the JP1/AJS3 mail monitoring process manually, select one of the following three methods:

- Right-click the JP1/AJS3 mail monitoring process icon displayed in the task tray, then choose **Close JP1/AJS2 mail monitoring process** from the menu displayed.
- Make users who are logged on to Windows log out, or
- Stop all JP1/AJS3 services on the system.

If the JP1/AJS3 mail monitoring process is not running when you execute an email sending job or email reception monitoring job, the job status changes to *Ended abnormally*. In this case, the system cannot send the email defined in an email sending job, or monitor for messages that match the monitoring conditions in an email reception monitoring job.

Note that the JP1/AJS3 mail monitoring process is terminated together with a JP1/AJS3 service if it is the one and only JP1/AJS3 service in the system. Also note that the JP1/AJS3 mail monitoring process is terminated together with the last JP1/AJS3 service to be stopped if there are two or more JP1/AJS3 services in the system.

Cautionary note

If you use the mail system linkage function on the desktop, do not start the JP1/AJS3 Mail service.

(2) Procedures for starting and ending the mail system linkage function used with a service

If you use the mail system linkage function with a service, you must start the JP1/AJS3 Mail service. You must also register the JP1/AJS3 Mail service that will be started in the system. For details about how to register the service in the system, see *When using the mail system linkage function from a service* in [2.3.4\(2\) Registering the mail system linkage function](#).

In the properties of the JP1/AJS3 Mail service registered in the system, the startup type is set to **Manual** and the account is set to **System**.

Because the JP1/AJS3 Mail service must be run from the account that you used to log on to Windows when you created the profile used by the mail system linkage function, ensure that this user account is set in the properties window of the JP1/AJS3 Mail service. Also, if necessary, change the startup type from **Manual** to **Auto**.

In addition, the JP1/AJS3 Mail service is not terminated together with the JP1/AJS3 service. When you manually stop the JP1/AJS3 service, you need to stop the JP1/AJS3 Mail service manually. Do one of the following to stop manually:

- From **Service** in the Control Panel, select **JP1/AJS3 Mail service**, then click the **Stop** button.
- Execute the `net stop JP1_AJS2_Mail` command.

If the JP1/AJS3 Mail service is not running when you execute an email sending job or email reception monitoring job, the job status changes to *Ended abnormally*. In this case, the system cannot send the email defined in an email sending job, or monitor for messages that match the monitoring conditions in an email reception monitoring job.

If you need the JP1/AJS3 Mail service to terminate together with the JP1/AJS3 service, you can set up service dependency relationships or use the activation management function of JP1/Base.

For details when mail system linkage is used within the service, see [2.3.8\(15\) Notes on using mail system linkage in a service](#).

Cautionary note

If you use the mail system linkage function with a service, do not start the JP1/AJS3 mail monitoring process.

2.3.7 Undoing the environment setup for mail system linkage

To undo the settings associated with the mail system linkage function:

1. Stop the JP1/AJS3 service.
2. End the mail system linkage function.
For details on how to end the mail system linkage function, see [2.3.6 Starting and ending the mail system linkage function](#).
3. Set the parameter that disables the mail system linkage function.
Execute the following command:

```
jajs_config -k [JP1_DEFAULT\JP1AOMAGENT\mail_link] "ExecMode"="N"
```

4. De-register the mail system linkage function from Windows.
 - When using the mail system linkage function from the desktop:

Delete the shortcut file you created in [2.3.4\(2\) Registering the mail system linkage function](#). Deleting the shortcut file disables starting of the mail monitoring process when you log on to Windows.

If you have pinned the shortcut file for the mail monitoring process to the Window Start screen and taskbar of Windows, unpin it. Also delete the shortcut file you created for the mail monitoring process.

If you have enabled Windows automatic logon, disable it if necessary. For details about how to disable Windows automatic logon, see the documentation provided by Microsoft.

- When using the mail system linkage function with a service:

Execute the following command:

```
sc delete JP1_AJS2_MAIL
```

This command deletes the JP1/AJS3 Mail service.

The `sc` command is provided by Microsoft. For details on this command, see the Microsoft documentation.

5. Restart the JP1/AJS3 service as required.

2.3.8 Cautionary notes on the mail system linkage function

This subsection gives some cautionary notes on the mail system linkage function.

(1) Using the Windows automatic logon function

- Holding down the **Shift** key during startup of Windows stops the starting of the Windows automatic logon function and displays the dialog box for logging on to Windows. If another user uses this dialog box to log on to Windows, the automatic Windows logon function might fail when Windows starts next time.
- Do not let any other user to log on to Windows when you are using the Windows automatic logon function. If you logged on as another user, make sure that the Windows automatic logon settings are not changed before using the Windows automatic logon function the next time. For details on how to check the Windows automatic logon settings, see the documentation provided by Microsoft.

(2) Linking a mail system other than Exchange Server using a service

- Although the mail system linkage service is registered using the name `JP1/AJS2 Mail`, type `JP1_AJS2_Mail` when you use the service name in a command such as `net start`.
- To link a SMTP/POP3 mail system, configure Exchange Server and a gateway and use them as a mail server. Note that you can use addresses included in the global address list (the name of an entity such as a mailbox managed by Exchange Server) and user addresses in other mail systems that are created and saved in personal address books. For details on linking mail systems from the desktop, see [2.3 Setup for linking mail systems \(for a Windows host when using Outlook\)](#).

(3) Mail system linkage function and cluster operation

- When used from the desktop:
JP1/AJS3 mail monitoring process does not support the cluster operation.
- When used with a service:
JP1/AJS3 Mail service does not support more than one logical host. Use the JP1/AJS3 Mail service on one of the logical hosts.

In a cluster environment, if you register the mail system linkage function as a resource in the cluster system and are using passing information, specify a folder on the shared disk as the destination for the passing information file. You specify this folder in the `EvjobInffile` environment setting parameter.

(4) Action to take after changing the environment set up for mail system linkage

If you change settings for any environment setting parameter used for the mail system linkage function, restart the JP1/AJS3 service.

If you are using the mail system linkage function on the desktop, also restart the JP1/AJS3 mail monitoring process. If you are using the mail system linkage function with a service, also restart the JP1/AJS3 Mail service.

(5) Deleting a file created after mail reception

JP1/AJS3 does not automatically delete body text, attached files, list file for attached files, or passing information files. These files are created after mail reception. Delete these files manually once they have become unnecessary, because they reduce the amount of available disk space.

For details on the location of these files, see *2.1.2(1) Behavior when receiving email (for Windows)*.

(6) Switching between desktop and service-based mail system linkage

- The JP1/AJS3 mail monitoring process does not terminate automatically when you switch the mail system linkage function from use on the desktop to use with a service, or disable the mail system linkage function. In these circumstances, terminate the JP1/AJS3 mail monitoring process manually.
- The JP1/AJS3 Mail service is created when you switch the mail system linkage function from use on the desktop to use with a service. Because the JP1/AJS3 Mail service must be run from the account that you used to log on to Windows when you created the profile used by the mail system linkage function, ensure that this user account is set in the properties window of the JP1/AJS3 Mail service.

(7) When a profile is configured to use personal folders

When a profile specified in the definition of an email sending or email reception monitoring job is configured to use a personal folder, an error might occur if the corresponding personal folder file is being used by another job program. This corresponding folder has extension `.pst`. The error occurs when the email sending or email reception monitoring job program accesses Outlook to send an email or monitor email reception. If this error occurs, the job status changes to *Ended abnormally*. For this reason, ensure that none of the following is taking place when you use an email sending job or email reception monitoring job:

- Another application process or mail account is viewing, updating, or deleting the personal folder.
- The profile or mail account is being configured.
- The personal folder file is open for editing in another program such as Notepad.
- On a desktop on which the mail system linkage function is used, Outlook is controlled by the email sending job or email reception monitoring job that remotely accesses the desktop from another desktop.

If an error occurs, make sure that none of these operations is taking place with respect to the personal folder file.

Then, re-execute the error email sending job or email reception monitoring job.

(8) Procedure for calculating the mail monitoring interval

For the email reception monitoring job, specify a monitoring interval that is shorter than the result of the following calculations. The default is 10 minutes.

1. In Outlook, measure how long it takes to complete transmission or reception of a single email message.
Measure this time using the profile that is actually used for the mail system linkage. Round the calculated time to the number of seconds and set this as the processing time for one email.
2. Calculate the monitoring processing time.
The expression is shown below.
$$\text{monitoring-processing-time} = (\text{maximum-number-of-email-reception-monitoring-jobs-monitored-concurrently-on-the-host}) \times \text{processing-time-for-one-email}$$
3. Calculate the send processing time.
The expression is shown below.
$$\text{sending-processing-time} = (\text{maximum-number-of-email-sending-jobs-executed-while-monitoring-an-email-reception-monitoring-jobs-on-the-host}) \times \text{processing-time-for-one-email}$$
4. Add the monitoring processing time and the send processing time determined in step 2 and step 3, and round the seconds to minutes.
5. Add one minute to the value determined in step 4 and set it as the mail monitoring interval (lower limit). However, we recommend that you set a value greater than the lower limit in actual operation.

(9) Notes on using Outlook

Before using Outlook, set it as the system's default email program. For details on how to do so, see Outlook Help. Unless Outlook is the default mail client, mail cannot be sent or received at execution of an email sending job or email reception monitoring job. A dialog box appears, prompting you to run Microsoft Outlook and set it as the default mail client.

(10) Outlook behavior and notes

The following describes Outlook behavior when the email sending job and email reception monitoring job are executed, and provides notes on Outlook that apply to when these jobs are executed.

- The mouse pointer might change to an hourglass that indicates that the application is performing processing.
- The active window might become inactive.
- The progress of the email sending job or email reception monitoring job is displayed.
- If you do not want to display the progress window, from Outlook menu bar, choose **Tools, Send/Receive, Show Progress**, and then select **Don't show this dialog box**.
- An Outlook button appears in the task bar.
- Do not use this icon to terminate Outlook during execution of the email sending job or email reception monitoring job.
- The Outlook window appears momentarily, at the start and end of the email sending job or email reception monitoring job.
- If virus-checking software is active, the logo of the software might appear.
- If the size of an email that Outlook is receiving is too large, email reception might be unable to finish. If email reception fails, set and apply the following environment variable in the user environment or system environment, as described below, and then re-execute the email reception monitoring job.

Environment variable name:

JP1AJS2_REC2

Description:

Set a value from 5 to 1,800 (in seconds).

When you execute an email reception monitoring job, the email receiving time for the job is extended by the time set in this environment variable. If you specify a value outside the 5 to 1,800 range, the email receiving time is not extended.

Regardless of whether the receiving time is extended, when the size of an email is 500 kilobytes, the required receiving time is about six seconds. When the size of an email is 1 megabyte, the required receiving time is about 12 seconds. Use these times as guidelines when setting the environment variable.

Note that the actual receiving time changes depending on the environment. Measure the email receiving time beforehand by using Outlook, and leave a sufficient margin when setting the environment variable.

- If it takes a long time for Outlook to receive email, the email reception monitoring job might be unable to detect the email being received. If the job cannot detect the email, the job will detect the email at the next execution cycle of email reception monitoring.
- Email reception monitoring job and unread emails in the Inbox of Outlook
An email reception monitoring job references and evaluates unread emails in the Inbox of Outlook until it finds emails that meet the conditions defined for the job. Therefore, if the Inbox of Outlook contains many unread emails that do not meet the defined conditions, the job might take a long time to determine the unread emails. To avoid this problem, use the email system in a way that prevents many unread emails from remaining in the Inbox.
- If you manually activate Outlook, while the email sending job or email reception monitoring job is sending or receiving email through activation of Outlook, then the Outlook window that you activated manually might be minimized into a task bar button. To use the instance of Outlook that you activated manually, in the task bar, right-click the **Outlook** button to display a menu, and then choose **Resize** or **Maximize**.

(11) Note on using Remote Desktop

Do not run the JP1/AJS3 mail monitoring process on Remote Desktop, because the mail system linkage might not operate correctly.

If you use Remote Desktop to log on remotely, remove the JP1/AJS3 mail monitoring process icon from the startup items so that the process will not start automatically. Note that if the icon is removed from the startup items, the process also does not start when you log in to the system console. Therefore, before using mail system linkage, make sure that the JP1/AJS3 mail monitoring process can be started on the system console, and start the process manually.

To manually start the mail monitoring process, click the icon for the JP1/AJS3 mail monitoring process that is pinned to the Windows Start screen or taskbar of Windows.

(12) If the environment settings cannot be read

If the settings cannot be read for the environment setting parameters to be used for the mail system linkage function, the JP1/AJS3 mail monitoring process and the JP1/AJS3 Mail service will start as usual. However, when an email sending job or email reception monitoring job is executed, the message `KAVT3409-E The environment definition could not be read.` is output to the integrated trace log and the job status changes to *Ended abnormally*. As a result, the system cannot send the email defined in an email sending job, or monitor for messages that match the monitoring conditions in an email reception monitoring job.

In this case, check whether message KAVT3409-E was output to the integrated trace log, and review the settings for the environment setting parameters used for the mail system linkage function. For details, see 4. *Messages beginning with KAVT (Messages about the event/action control)* in the manual *JP1/Automatic Job Management System 3 Messages*. After changing the settings for the environment setting parameters used for the mail system linkage function, you must restart the JP1/AJS3 mail monitoring process or the JP1/AJS3 Mail service, as well as the JP1/AJS3 service.

(13) Notes on Outlook licenses and certificate expiration

If you start an unlicensed copy of Outlook more than a predetermined number of times, or attempt to run Outlook with an expired certificate, Outlook will not start.

If you execute an email sending job or email reception monitoring job in this state, the job status changes to *Ended abnormally*, and the system is unable to send email or detect received email.

- Licenses

You can start an unlicensed copy of Outlook a limited number of times, beyond which the program will no longer start. Because the number of times you can start a particular instance of Outlook differs depending on its specifications, do not execute an email sending job or email reception monitoring job if JP1/AJS3 is linked to an unlicensed copy of Outlook.

- Certificates

If you use a certificate to send and receive email, Outlook will not start if the certificate has expired. Check the expiration date of the certificate. Because different certificates have different expiration dates, check with the authority that issued the certificate.

For details on how to use certificates to send and receive email in Outlook, see Outlook Help.

(14) Email encryption and digital signature

Mail encryption and digital signatures are not supported for email sending jobs and email reception monitoring jobs.

When you use the mail system linkage function, do not encrypt the mail or add a digital signature to it.

(15) Notes on using mail system linkage in a service

To use mail system linkage in a service in an environment in which Outlook 2021, Outlook 2019, or the Click-to-Run version of Outlook 2016 is installed, start the JP1/AJS3 Mail service while Outlook is not running. The JP1/AJS3 Mail service cannot start while Outlook is running.

If you start the JP1/AJS3 Mail service after starting Outlook, log off from the PC running Outlook, and then log in again and start the JP1/AJS3 Mail service.

To check whether your version of Outlook is the Click-to-Run version, see the publicly available information from Microsoft.

(16) Action to take after changing how emails are sent

If you change an email sending job that uses Outlook into a job that does not use Outlook, perform the setup needed for the job to send email without Outlook. For details on the setup needed to send emails without using Outlook, see [2.2 Setup for linking mail systems \(for a Windows host when not using Outlook\)](#).

Some differences between an email sending job that uses Outlook and one that does not use Outlook might require you to change job definitions. For the differences between an email sending job that uses Outlook and one that does not use Outlook, see [4.3.4 Environment settings for action jobs](#) in the *JP1/Automatic Job Management System 3 System Design (Configuration) Guide*.

If the differences do not affect job operations, you do not need to change any job definitions. Instead, use the name of the existing profile as the name of the profile that will be created.

(17) Troubleshooting

For details on how to troubleshoot problems associated with mail system linkage, see *2.9 Troubleshooting problems related to mail system linkage (for Windows only)* in the manual *JP1/Automatic Job Management System 3 Troubleshooting*.

2.4 Setup for linking mail systems (for a UNIX host)

For UNIX hosts to link with mail systems, the sendmail or the postfix mail software is required. On the host on which the email sending job and email reception monitoring job are to be executed, use sendmail or postfix to set up an SMTP mail server so that the host can send and receive emails by itself.

You must also set up the host so that it can send and receive emails (mail that complies with RFC822) delivered from the SMTP mail server.

The following figure shows an example of a system configuration that uses mail system linkage.

Figure 2–12: Example of a system configuration using mail system linkage

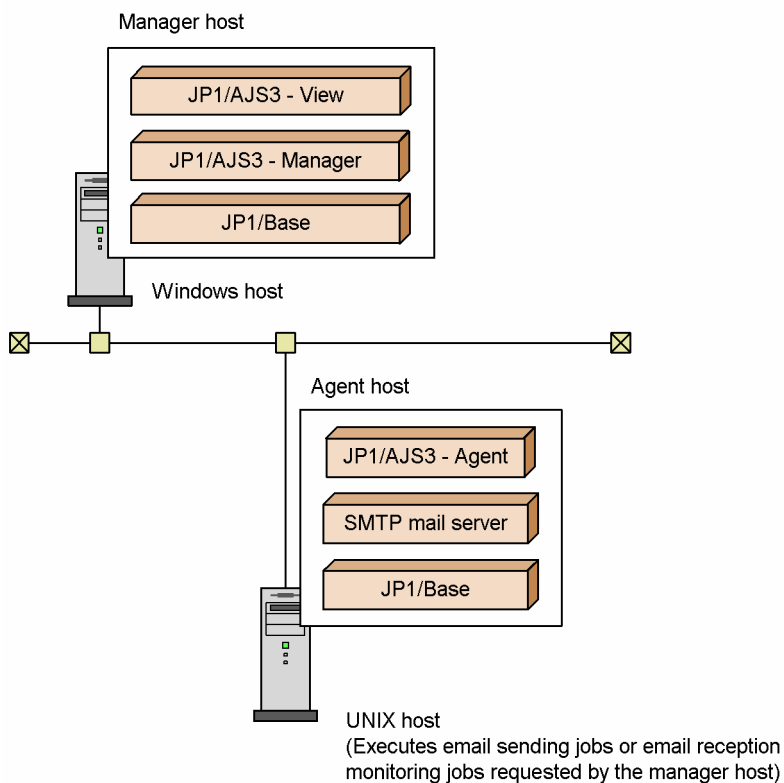

The following figure shows the agent host setup procedures for linking mail systems. Note that you need not set up the manager host for the mail system linkage.

Figure 2–13: Agent host setup procedures for linking mail systems

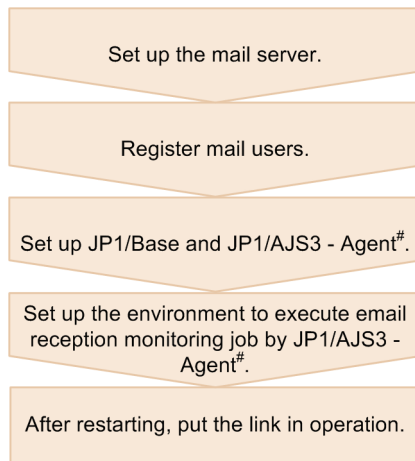

JP1/AJS3 - Manager can be used as an agent host.

If you execute the email sending job, verify that email can normally be sent after the mail server has been set up. When you do this verification, execute the following `sendmail` command without starting JP1/AJS3:

```
/usr/lib/sendmail -i -t < file-name
```

In *file-name*, specify the name of a text file that is in the following format:

The entry format depends on the version of `sendmail` used to send emails.

If the version of `sendmail` is earlier than 8.14.0:

```
To:Δrecipient
Subject:Δsubject
(Linefeed)
mail-body
. (A line containing only a period indicates the end of data.)
```

Legend:

Δ: Space

The recipient specification must follow the keyword `To:`, `Cc:`, or `Bcc:`. The first letter of each keyword must be upper case and the other letters must be lower case. A space must be placed between the keyword (`To:`, `Cc:`, or `Bcc:`) and *recipient*.

The subject line specification must follow the keyword `Subject:`. The first letter of the keyword must be upper case and the other letters must be lower case. A space must be placed between `Subject:` and *subject*.

If the version of `sendmail` is 8.14.0 or later, or if postfix is used:

```
To:recipient
Subject:subject
(Linefeed)
mail-body
. (A line containing only a period indicates the end of data.)
```

The recipient specification must follow the keyword `To:`, `Cc:`, or `Bcc:`. The first letter of each keyword must be upper case and the other letters must be lower case.

The subject line specification must follow the keyword `Subject:`. The first letter of the keyword must be upper case and the other letters must be lower case.

Unlike the `sendmail` from versions earlier than 8.14.0, `sendmail` version 8.14.0 or later does not require you to enter a single-byte space before *recipient* and *subject*.

When you execute the `sendmail` command shown above, make sure the OS user account is the same as the user account used when the email sending job is executed.

The following provides detailed information that is required after the mail server has been set up.

2.4.1 Email reception monitoring job and mail users

On the mail server, you must register the mail users that will be monitored by an email reception monitoring job. Register these mail users as JP1/AJS3-specific mail users on the mail server.

2.4.2 Setting up the environment for an email reception monitoring job

This subsection describes the environment setup procedure in JP1/AJS3 and items to be specified for using an email reception monitoring job on a UNIX host.

Note that if you use the email sending job on a UNIX host, the job can be used regardless of the settings of environment setting parameters described below.

(1) Procedure for setting up the environment

To set up the environment:

1. Use the environment setting parameters for event/action control to set up the environment for an email reception monitoring job.

For details on how to do so, see [\(2\) Procedure for setting up event/action control](#).

2. Set up the mail delivery function.

For further details regarding setting up the mail delivery function, see [2.4.3 Setting up the mail delivery function](#).

3. Set up a mail filter application (code conversion tool), as required.

To enable reception monitoring of emails that use multi-byte characters and MIME-encoded emails, you need to set up separately the mail filter application that will be used for linking with the mail system. For details on a mail filter application, see [2.5 Mail filtering application specifications](#).

4. After executing the command, restart JP1/AJS3.

The email reception monitoring job becomes usable with the specified settings.

(2) Procedure for setting up event/action control

To change the definition of the environment setting parameters:

1. Execute the following command to set the environment setting parameters that define the environment for email reception monitoring jobs.

```
jajs_config -k definition-key-name "environment-setting-parameter-1"=definition-content-1
["environment-setting-parameter-2"=definition-content-2]
["environment-setting-parameter-3"=definition-content-3]
```

```
[ "environment-setting-parameter-4"=definition-content-4]
["environment-setting-parameter-5"=definition-content-5]
["environment-setting-parameter-6"=definition-content-6]
["environment-setting-parameter-7"=definition-content-7]
```

For details on the environment setting parameters required to define the environment for email reception monitoring jobs, see (3) *Environment setting parameters used for email reception monitoring jobs*.

In the default environment, email reception monitoring jobs are disabled. To enable the use of email reception monitoring jobs, specify U for the ExecMode environment setting parameter.

(3) Environment setting parameters used for email reception monitoring jobs

The table below lists the event/action control environment setting parameters associated with email reception monitoring jobs. For details on the environment setting parameters that relate to event/action control in general, see 20.6 *Setting up the event/action control environment* in the *JP1/Automatic Job Management System 3 Configuration Guide*.

Parameters not described in the manual are for maintenance. Do not change these values.

Table 2–7: Environment setting parameters related to an email reception monitoring job

Definition key	Environment setting parameter	Defined information
[{JP1_DEFAULT <i>logical-host-name</i> }\JP1AOMAGENT\mail_link]#	"ReceiveIntervalC"=	Interval at which mail reception is monitored
	"UserName"=	User name
	"MailFileDir"=	Mail file directory name
	"MailFileName"=	Mail storage file name
	"NotMatchMailDir"=	Directory in which the file for storing unmatched email is stored
[JP1_DEFAULT\JP1AOMAGENT\mail_link]	"ExecMode"=	Whether to use the mail system linkage function

#

Item selection in the {JP1_DEFAULT|*logical-host-name*} part depends on whether the host is a physical host or a logical host. If the host is a physical host, specify JP1_DEFAULT. If the host is a logical host, specify *logical-host-name*.

For details about the specification on a logical host, see 10.6.1(4) *Cautionary notes on the execution environment for event jobs and custom event jobs* in the *JP1/Automatic Job Management System 3 Administration Guide*.

The following describes details of the environment setting parameter definitions:

"ReceiveIntervalC"=dword:*time-interval*

Specify the interval at which email reception is monitored.

Specifiable values

A hexadecimal value (in minutes) from 00000001 to 000005A0 (1 to 1,440 in decimal)

Default value

dword:0000000A (10 in decimal)

Recommended value

Set a value appropriate for the operating environment.

When the setting takes effect

The next time the JP1/AJS3 service starts

"UserName"="user-name"

Specify the name of a user for which you want to monitor the reception of email.

Note that email which is subject to reception monitoring is stored in a file that has the same name as the user name specified in this parameter. The directory in which the file is stored is specified by using the MailFileDir environment setting parameter.

Specifiable values

A character string of no more than 256 bytes

Default value

Blank

Recommended value

Set a value appropriate for the operating environment.

When the setting takes effect

The next time the JP1/AJS3 service starts

"MailFileDir"="mail-file-directory-name"

Specify the name of the mail file directory storing email for the user specified with the UserName environment setting parameter. In JP1/AJS3, email is received using the mail delivery function. Therefore, always specify /var/opt/jplajs2/tmp/mailbox. If you do not specify the mail file directory name, /var/opt/jplajs2/tmp/mailbox is assumed. For further details regarding setting up the mail delivery function, see [2.4.3 Setting up the mail delivery function](#).

Specifiable values

A character string of no more than 180 bytes

Default value

/var/opt/jplajs2/tmp/mailbox

Recommended value

/var/opt/jplajs2/tmp/mailbox

When the setting takes effect

The next time the JP1/AJS3 service starts

"MailFileName"="mail-storage-file-name"

Specify the full path name of the file storing the email that satisfies the monitoring condition.

Specify a file different from the mail file with the user name specified for the UserName environment setting parameter for storage in the directory specified by using the MailFileDir environment setting parameter.

Specifiable values

A character string of no more than 255 bytes

Default value

Blank

Recommended value

Set a value appropriate for the operating environment.

When the setting takes effect

The next time the JP1/AJS3 service starts

"NotMatchMailDir"="*directory-in-which-file-for-storing-unmatched-email-is-stored*"

Specify the full path name of the directory that contains the file storing email that does not satisfy the monitoring condition.

- Specify a different directory from the directory specified for the MailFileDir environment setting parameter.
- If you do not specify a directory name, the system deletes any email that does not satisfy the monitoring condition.

Specifiable values

A character string of no more than 180 bytes

Default value

Blank

Recommended value

Set a value appropriate for the operating environment.

When the setting takes effect

The next time the JP1/AJS3 service starts

"ReceivedMailFormat"=dword:{0|1}

Specify the data format of the mail header of the emails to be received.

The data format you specify is determined by the combination of mail system versions that will be linked.

Specifiable values

0

This data format includes the single-byte space that is automatically inserted into the mail header data of the emails to be received.

Example:Subject:ΔTITLE (Δ indicates a single-byte space.)

Specify 0 if the sendmail version for one or both of the sending and receiving hosts is earlier than 8.14.0.

1

This data format does not include the single-byte space that is automatically inserted into the mail header data of the emails to be received.

Example:Subject:TITLE

Specify this value if the hosts that send and receive emails both use postfix or sendmail 8.14.0 or later.

Default value

0

Recommended value

Set a value appropriate for the operating environment.

When the setting takes effect

The next time the JP1/AJS3 service starts

Supplementary note

The following table describes the version combinations of sendmail on the sending and receiving hosts and the value to be specified for each combination.

Table 2–8: The combinations of mail systems and the values to be specified in the ReceivedMailFormat environment setting parameter

Version of sendmail on the host receiving email	Version of sendmail on host sending email (Sending by an email sending job in JP1/AJS3 or by sendmail alone)	
	Earlier than 8.14.0	8.14.0 or later
Earlier than 8.14.0	0	0
8.14.0 or later	0	1

Cautionary notes

- If you specify 0 in the ReceivedMailFormat environment setting parameter for the combination in the above table when 1 must be specified, the email reception monitoring job will not be able to detect any emails meeting the monitoring conditions defined for the job even if received.

If you specify 1 in the ReceivedMailFormat environment setting parameter for a combination when 0 must be specified, the MLRCVSUBJECT macro variable stores the subject data of an email detected by the email reception monitoring job where a single-byte space has been inserted at the beginning.

Because of this, specify a value that matches the combination of mail systems you are using.

- If the version of sendmail on the receiving host is 8.14.0 or later, set up the host so that it receives only the emails sent the sendmail whose version is earlier than 8.14.0, or so that it receives only the emails sent by the sendmail whose version is 8.14.0 or later.

Also, in the ReceivedMailFormat environment setting parameter, specify a value that matches the format of the emails to be sent.

- If emails are to be sent by using, for example, the telnet command, and not by using either an email sending job or sendmail, the format of the mail header to be sent is as follows:

- Header format corresponding to the data format used if the sendmail version is earlier than 8.14.0:

A single-byte space is inserted between the field name and the field data.

Example: "Subject: ΔTITLE" (Δ indicates a single-byte space.)

- Header format corresponding to the data format used if the sendmail version is 8.14.0 or later:

A single-byte space is not inserted between the field name and the field data.

Example: "Subject: TITLE"

"ExecMode"="{U|N}"

Specify whether to use an email reception monitoring job.

Specifiable values

U

An email reception monitoring job is used.

N

An email reception monitoring job is not used.

Default value

N

Recommended value

Set a value appropriate for the operating environment.

When the setting takes effect

The next time the JP1/AJS3 service starts

2.4.3 Setting up the mail delivery function

Before you can execute the email reception monitoring job, you must set up the mail delivery function. When the SMTP mail server receives emails, this function forwards them to mail files that JP1/AJS3 uses for receiving emails. The email reception monitoring job references the emails saved in those mail files, instead of the ones on the SMTP mail server. This is because direct access to the SMTP mail server might produce inconsistent results depending on when the emails are received.

The name of the mail file directory specified for reception is always `/var/opt/jplajs2/tmp/mailbox`. Be sure to specify `/var/opt/jplajs2/tmp/mailbox` as the mail file directory name in setting up the email reception monitoring job.

When setting up the mail delivery function, modify the alias file in the SMTP mail server so that you can receive mail from mail users to be monitored for mail reception.

To set up the mail delivery function:

1. In the alias file in the SMTP mail server, define the mail users to be monitored and enter the `jpomailrecv` command for enabling the users to send and receive mail.

Example: Specify `mailuser` for the mail user to be monitored and set the retry timeout to 10 minutes.

```
mailuser: "|/opt/jplajs2/bin/jpomailrecv -u mailuser -t 10"
```

For details about the `jpomailrecv` command, see *jpomailrecv (UNIX only)* in 2. *Commands Used during Setup* in the manual *JP1/Automatic Job Management System 3 Command Reference*.

The alias file is usually named `aliases`. For further details regarding the alias file, see the SMTP mail system documentation.

2. Execute the `newaliases` command or `sendmail -bi` command for the SMTP mail system.

The alias file you edited becomes effective.

Cautionary note on typing the alias file

When you type the `jpomailrecv` command in the alias file, use up to 250 bytes excluding pipes. If the command you want to enter is longer than 250 bytes, create a script file, type the command in it, then code the name of the script file in the alias file.

2.4.4 Starting and ending the mail system linkage function

This subsection describes how to start and end the mail system linkage function. Starting and ending procedures are described separately according to whether the operation uses an email sending job or an email reception monitoring job.

(1) Starting and ending the mail system linkage function if an email sending job is used

After starting the JP1/AJS3 service, you can use an email sending job regardless of the environment setting parameter settings for the mail system linkage function.

After stopping the JP1/AJS3 service, you will no longer be able to use the email sending job.

(2) Starting and ending the mail system linkage function if an email reception monitoring job is used

After starting the JP1/AJS3 service, you can use an email reception monitoring job if U is set in the ExecMode environment setting parameter for the mail system linkage function.

To switch the operating status of the email reception monitoring job from enabled to disabled, set N in the ExecMode environment setting parameter for the mail system linkage function, and then restart the JP1/AJS3 service.

After stopping the JP1/AJS3 service, you will no longer be able to use the email sending job.

For details on the ExecMode parameter, see [2.4.2 Setting up the environment for an email reception monitoring job](#).

2.4.5 Cautionary notes on the mail system linkage function

This subsection gives some cautionary notes on the mail system linkage function.

Cautionary notes on using the mail system linkage function on a UNIX host

- A mail file where mail is stored when an error occurs is created for each package activated by the service. The mail file is usually created in `/var/opt/jplajs2/sys/infoagt/tmp/mail/errmail`.
- During email reception monitoring, emails that meet the monitoring conditions of multiple email reception monitoring jobs are stored in the email storage file specified in the environment settings file. The emails are stored if saving emails is specified for at least one of the email reception monitoring jobs.
- JP1/AJS3 does not automatically delete the passing information storage file, mail storage file, mismatching mail storage file, received-mail list file, or error mail file created by the email reception monitoring job. Delete these files manually once they have become unnecessary, because they reduce the amount of available disk space.
- Email reception monitoring is executed after an email reception monitoring job starts. No emails are monitored until at least one email reception monitoring job starts.
- Although the mail system linkage function monitors mail files at the specified interval, if the mail file contains multiple emails, it picks up the emails one by one. It takes about one second to handle each email.
- Halfwidth spaces, tabs and linefeed codes in the body of received email are treated as follows:
Halfwidth spaces, tabs, and linefeed codes contained in a string in the body:
Conditional judgment eliminates the halfwidth spaces, tabs, and linefeed codes from the string. If the resulting string matches an expected monitoring condition string, the system assumes that a condition is met.
Example (Δ: Space):
Expected string: ABC
String in the body of received email: AΔBC
Halfwidth spaces, tabs, and linefeed codes before or after a string in the body:
If the string matches an expected monitoring condition string, the system assumes that a condition is met.
Example (Δ: Space):
Expected string: ABC
String in the body of received email: ABCΔ
- If you specify multi-byte characters (Japanese) or single-byte katakana characters in the subject line or message text in the definition of an email sending job, characters will be unreadable and the email will not be sent successfully. Therefore, do not specify multi-byte characters (Japanese) or single-byte katakana characters in the

subject line or message text. Note, however, that if you specify a message text file containing the text of an email converted to JIS encoding, the file can be sent successfully.

- The sendmail function might use a program that restricts the operation of mail delivery functions that are set up later than the sendmail function. That program might prevent the JP1/AJS3 mail delivery function from running normally. In such a case, see the documentation for the program that restricts mail delivery functions and set up the program so that the JP1/AJS3 mail delivery function can run normally. For details about the mail delivery function, see [2.4.3 Setting up the mail delivery function](#).

Example:

Emails cannot be delivered because the `jpomailrecv` command, which is a part of the mail delivery function, cannot be started from a sendmail alias because of the `smrsh` limitation on sendmail.

<Action to be taken>

Create a symbolic link to the `jpomailrecv` command.

Example of creating a symbolic link with the `ln` command:

```
ln -s /opt/jplajs2/bin/jpomailrecv /etc/smrsh/jpomailrecv
```

Note that the location for creating the symbolic link might vary according to the system environment. Note also that the `smrsh` limitation described above is only an example. For details about the sendmail limitations, see the sendmail Help and other sendmail documentation.

For details about the `ln` command, see the documentation for the OS.

For details about aliases, see the SMTP mail system documentation.

For details about the `jpomailrecv` command, see *jpomailrecv (UNIX only)* in *2. Commands Used during Setup* in the manual *JP1/Automatic Job Management System 3 Command Reference*.

- Attached files cannot be specified for an email sending job.
To run an email sending job on a UNIX host, you must specify **UNIX** for **Platform** in the definition of the email sending job. When **UNIX** is specified for **Platform**, you will not be able to specify any attached files for the email sending job.
If **PC** (Windows) is specified for **Platform** in the definition of the email sending job, you can specify attached files for the email sending job. However, if the email sending job with attached files specified is run on a UNIX host, the job ends abnormally because the specified platform type is invalid.

2.5 Mail filtering application specifications

The UNIX version of the JP1/AJS3 mail system linkage function supports email in the RFC822 format only. JP1/AJS3 can, however, handle the following email if you install an appropriate mail filter application:

- Email using Kanji or other multi-byte characters
- Email containing MIME or other encoded text

A mail filter application converts the above email to a character code system supported by the recipient host (language environment in which JP1/AJS3 is running).

The following figure gives an overview of how a mail filter application converts email.

Figure 2–14: Overview of mail conversion using a mail filter application

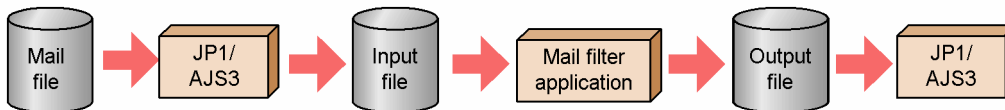

Email converted by the mail filter application is only used for mail reception by the mail system linkage function. When storing the received mail, the system stores the version before it is converted by the mail filter application.

Prepare a mail filter application when setting up mail system linkage.

The subsections below describe the specifications of a mail filter application. You can create any mail filter application as long as it satisfies the input/output and return value requirements described below.

2.5.1 Mail Filter Application Specifications

This subsection describes the specifications of a mail filter application.

(1) Files used by the mail filter application

The following table lists the files the mail filter application uses:

Table 2–9: Files used by the mail filter application

No.	File name	Description
1	/opt/jplajs2/usrtools/converter	Name of the mail filter application.
2	/opt/jplajs2/usrtools/converterin	Input file. This file stores a single email message JP1/AJS3 extracts from the email. JP1/AJS3 stores email in this file before starting the mail filter application.
3	/opt/jplajs2/usrtools/converterout	Output file. This file stores the email converted by the mail filter application. Once the mail filter application terminates normally, JP1/AJS3 extracts the email from this file and determines whether it satisfies the monitoring condition.

Specify the file name listed in No. 1 of the table as the name of the mail filter application. Specify the name listed in No. 2 of the table for the input file for the mail filter application. Specify the name listed in No. 3 of the table for the file to which the converted email is output.

If you specify a logical host name, the file names are assumed as follows:

Example: If the specified logical host name is `HOSTNAME1`

- Mail filter application name: `/opt/jplajs2/usrtools/converterHOSTNAME1`
- Input file name: `/opt/jplajs2/usrtools/converterinHOSTNAME1`
- Output file name: `/opt/jplajs2/usrtools/converteroutHOSTNAME1`

Note: Do not include a space between `/opt/jplajs2/usrtools/converter` and the logical host name, between `/opt/jplajs2/usrtools/converterin` and the logical host name, or between `/opt/jplajs2/usrtools/converterout` and the logical host name.

(2) Return values from the mail filter application

The mail filter application must pass one of the return values below to JP1/AJS3 upon the completion of conversion.

JP1/AJS3 behaves differently depending on the passed return value. The following table shows return values from the mail filter application and corresponding JP1/AJS3 action:

Table 2–10: Return values and corresponding JP1/AJS3 action

Return value	Meaning	JP1/AJS3 action
0	Ended normally	Extracts the email from the file output by the mail filter application and determines whether it satisfies the monitoring condition. Uses the mail filter application to convert the next email.
Non-0	Ended abnormally	Outputs a message and disables the mail system linkage function. Stores the email in the error email file. Does not convert the next mail until JP1/AJS3 is restarted.

How the mail filter application passes a return value depends on the language in which it is created. Use either of the following:

- For the shell language: `exit` command
- For the C language: `exit()` system call

2.5.2 Specifications related to character set conversion

This subsection describes specifications regarding how the mail filter application converts email containing Kanji or other multi-byte characters so that the JP1/AJS3 mail system linkage function can use the email.

If you want the mail system linkage function to handle email that contains Kanji or other multi-byte characters, it is necessary to convert its character set. Otherwise, the character set used in the email does not match that for the language with which JP1/AJS3 is running, thus failing to satisfy the condition for the email reception monitoring job. Create a mail filter application that converts the character set according to the language settings of the computer on which JP1/AJS3 is running.

JP1/AJS3 provides a sample shell script that converts a character set. To create a mail filter application, you can use and modify this sample. For details on the sample shell script, see [2.5.4 Sample shell script for a mail filter application](#).

2.5.3 Specifications related to decoding MIME or other encoded email

This subsection describes specifications regarding how the mail filter application converts email encoded in MIME or other formats so that the JP1/AJS3 mail system linkage function can use the email.

When the mail system receives MIME or other encoded email, it must detect encoding and decode the email accordingly.

Create a mail filter application that can decode encoded email. The mail filter application must also be able to convert the character code of the email text if the text uses a different character code than that of the language with which JP1/AJS3 is running.

2.5.4 Sample shell script for a mail filter application

JP1/AJS3 provides a sample shell script for a mail filter application that converts a character code. This shell script converts only the character code of the received email text; it does not decode MIME or other encoding.

The name of the file is `/opt/jp1ajs2/tools/converter`.

The character code conversion by this sample shell script varies according to the OS as follows:

- When the OS is Solaris and Linux: JIS to EUC
- When the OS is other than Solaris and Linux: JIS to Shift-JIS

Note that Solaris 11 does not support the sample shell script. If the OS is Solaris 11 and a mail filter application will be used, create a shell script that matches the character encoding used for the emails to be received and the character encoding being used by JP1/AJS3.

2.5.5 Setting up a mail filter application

The following shows the procedure for setting up a mail filter application.

To set up a mail filter application:

1. Prepare a mail filter application.
Prepare an appropriate program or shell script that complies with the mail filter application specifications, described above. Name the file `converter`.
2. Create the `/opt/jp1ajs2/usertools` directory.
3. Assign a read/write permission to the directory created in step 2.
4. Place the mail filter application in the directory created in step 2.
5. Assign an execution permission to the mail filter application.

2.6 Defining email reception monitoring job

An email reception monitoring job monitors the Inbox of the email client software, and detects when email that matches the monitoring conditions is received. Before executing such a job, you must define what kind of received email you want to satisfy the conditions.

The conditions you can set for an email reception monitoring job are the sender, the subject, and the body text. If a received email matches the conditions you define, the job ends normally. You must define at least one of these three items.

Only the unread emails in the Inbox of the email client software can be monitored to find out whether they satisfy the conditions. The system does not compare opened emails against the monitoring conditions.

This section describes how to define an email reception monitoring job.

2.6.1 Defining an email reception monitoring job

To receive email, define the mail reception using either of the following methods:

- In the Jobnet Editor window of JP1/AJS3 - View, define the email Receive Mail job.
- Define the necessary information in the unit definition file and execute the `ajsdefine` command.

As the details (or parameters) of email reception, specify the following items:

- Platform
- Profile name (for Windows)
- List of senders, list of subjects, list of message texts

In addition, you can specify the list file for attached files (in Windows) or the list of received email (in UNIX) as required.

(1) Judging whether received email satisfies the monitoring conditions

A list of senders, a list of subjects, and a list of message texts can be used as monitoring conditions for received email. You must set at least one of these three conditions. The system assumes that an event occurred when a message satisfies all the conditions you set. If any of the conditions is not satisfied, the system assumes that an event has not occurred.

The three monitoring conditions are described below.

- List of senders
Judgment is based on whether the sender of a received email matches a sender you specified.
This condition is satisfied if the email address of the sender matches an email address in the list of senders.
If a sender's email address or an email address set as a condition includes a single-byte space, the space is ignored for judgment purposes.
- List of subjects
Judgment is based on whether the subject line of a received email contains the specified character string.
This condition is satisfied if the subject line of the email contains a character string specified in the list of subjects. If you specify more than one character string in the list of subjects, an email message satisfies the condition if its subject line contains any one of those character strings.
If the subject of an email or a character string specified in the list of subjects includes a single-byte space, the space is ignored for judgment purposes.

- List of message texts

Judgment is based on whether the body of a received email contains the specified character string.

This condition is satisfied if the body of the email contains a character string specified in the list of message texts. If you specify more than one character string in the list of message texts, an email message satisfies the condition if its body contains any one of those character strings.

If the body of an email or a character string specified in the list of message texts includes a single-byte space, the space is ignored for judgment purposes.

Cautionary notes

- In UNIX, of files attached to an email in MIME format, only text files can be judged according to the list of message texts condition.
- Depending on the configuration of the mail system, information might be added to the sender's email address when email is received. For example, information might be added if the mail server is connected via a gateway.
- With the email reception monitoring job, the sender's email address satisfies the condition only when the whole address matches. The format of the email address set in received email as the sender address depends on what protocol the sender uses to connect to the mail server (for example, connecting with an SMTP server or Exchange Server). The sender address format might also change according to the mail system specifications or settings. After the mail system has been set up, try sending and receiving email so that you can check the sender address format actually set in the received email.

The procedure for checking the sender address format is as follows:

1. Define an email reception monitoring job and an email sending job.

In the definition of the email reception monitoring job, specify a monitoring condition for the subject line or body, and specify MLRCVADDRESS (sender of received email) as the passing information.

In addition, define an email sending job that will be executed after the email reception monitoring job has judged that the condition is satisfied, and that will receive MLRCVADDRESS and set it for the subject line or the body.

2. Execute the email reception monitoring job.
3. Send email.

Make sure that you send arbitrary email that satisfies the monitoring condition specified in step 1.

4. Check the data that has been passed.

In the subject line or the body of the email sent by the email sending job, executed after the monitoring condition in the email reception monitoring job is satisfied, check the data that has been passed via MLRCVADDRESS.

For details about MLRCVADDRESS, see *B. Information Passed by Event Jobs and Custom Event Jobs* in the *JPI/Automatic Job Management System 3 System Design (Work Tasks) Guide*.

- In Windows, a host can execute a maximum of 60 email reception monitoring jobs. An error occurs at execution of the 61st and subsequent jobs. The same restriction applies when more than one scheduler service is active.

2.6.2 Format of received email

All the received email is in text format. If rich text mail is sent, it is treated as plain text email when it is received. You cannot add character modification and font specification as reception conditions.

2.6.3 List file for email reception monitoring job (Windows only)

When an email reception monitoring job detects the reception of an email with attached files, you can have the system create a file that lists the attached files.

To create a list file, you need to specify the name of the list file, as well as the folder where the attached files are to be saved.

To specify this information, use one of the following methods:

- When defining the email reception monitoring job from the Jobnet Editor window of JP1/AJS3 - View
 1. In the Detailed Definition - [Receive Mail] dialog box, select the **PC** option for the **Platform** setting, and then click the **Set** button under **Option after receive**.
The Detailed Definition - [Receive Mail] - [Option after Receive] dialog box appears.
 2. In the Detailed Definition - [Receive Mail] - [Option after Receive] dialog box, enter the relevant settings in the **Folder for saving attached file** and **List file** fields.

For details on the definitions you can set, see *12.4.20 Detailed Definition - [Receive Mail] dialog box* in the *JP1/Automatic Job Management System 3 Operator's Guide*. See also *12.4.21 Detailed Definition - [Receive Mail] - [Option after Receive] dialog box* in the *JP1/Automatic Job Management System 3 Operator's Guide*.

- When defining the email reception monitoring job using the `ajsdefine` command
When writing the definition information for the job in the unit definition file, specify `PC` as the platform. Also specify the folder for saving attached files and the list file name.
For details on how to define these parameters, see `ajsdefine` in *3. Commands Used for Normal Operations* in the manual *JP1/Automatic Job Management System 3 Command Reference*, *5.1.1 Format of unit definition files* in the manual *JP1/Automatic Job Management System 3 Command Reference*. See also *5.2.11 Email reception monitoring job definition* in the manual *JP1/Automatic Job Management System 3 Command Reference*.

When the email reception monitoring job detects that an email has been received, information about the sender, when the email was received, the number of attached files, and details of each file is output to the list file for attached files.

The information output to the list file falls into two categories:

- File information
Information about a file attached to the received email.
The full path of the attached file (including the folder where the file is saved) is output to the list file.
- OLE object information
Information relating to an object embedded in the email message by the mail client software that sent the message (for example a Microsoft Outlook item).
Windows cannot handle these objects as system files. For this reason, OLE objects are not saved to the folder for saving attached files. Instead, the message `The attached file cannot be saved since it is an OLE object` is output to the list file.

The following table shows the format of list files.

Table 2–11: Format of list files

Place	Format	Output content
1 st line	<code>From: sender</code>	The sender of the email.
2 nd line	<code>Date: date</code>	The date and time when the email was received.

Place	Format	Output content
3 rd line	Files: <i>number-of-attached-files</i>	The number of files (files and OLE objects) attached to the email.
4 th and later lines	Information about individual attachments	Information about each attached file. Each line of information represents a different file. <ul style="list-style-type: none"> Files: The full path of the file OLE objects: The character string The attached file cannot be saved since it is an OLE object.

If you specify a list file name but not folder for saving attached files when defining an email reception monitoring job, 0 appears for Files (the number of files) in the list file. In this case, information about individual attachments is not output.

If the specified list file already exists, the system overwrites the existing file with the new information.

The following figure shows an example of the information output to a list file:

Figure 2–15: Example of output to list file

Example format

```

From:Sales
Date:20XX/08/01 12:34
Files:3
C:\USER\DEFAULT\customer-A\estimate.doc
The attached file cannot be saved since it is an OLE object.
C:\USER\DEFAULT\customer\order.xls

```

In this example, the list file presents the following information about the received email:

- The email sender was Sales.
- The email was received at 12:34 on 1 August 20XX.
- The email has three attachments (estimate.doc, an OLE object, and order.xls). The attached files, with the exception of the OLE object, were saved to the folder C:\USER\DEFAULT\customer-A.

2.6.4 Reception list file (UNIX only)

When a UNIX host receives email, it can extract the contents of the received email and create a file that records the extracts in a list format.

The following table shows the format of a reception list file.

Table 2–12: Format of a reception list file

Place	Format	Contents
1 st line	SENDER: <i>sender</i>	<i>sender</i> is replaced by the name of the actual email sender.
2 nd line	DATE: <i>date</i>	<i>date</i> is replaced by the actual date when the email is received.
3 rd line	SUBJECT: <i>subject</i>	<i>subject</i> is replaced by the title of the email.

An example format of a reception list file is as follows.

Figure 2–16: Example format of a reception list file

Example format

```
SENDER:Sales  
DATE:20XX/08/01 12:34  
SUBJECT:Test
```

2.6.5 Cautionary note on defining an email reception monitoring job

When specifying a body text file, attached file storage folder, or list file in an email reception monitoring job, specify a file or folder stored on a local drive. You cannot specify a file or folder on a network drive (a file or folder specified in the `\\computer-name\folder\` format or stored on a drive assigned as a network drive).

2.7 Defining email sending job

You can define the type of email to be sent when an email sending job is executed.

2.7.1 Defining email sending job

To send email, define an email sending job using either of the following two methods:

- In the Jobnet Editor window of JP1/AJS3 - View, define the email sending job.
- Define the necessary information in the unit definition file and execute the `ajsdefine` command.

As the details (or parameters) of the email sending job, specify the following items:

- Platform
- Recipient
- Profile name (for Windows)

Specify the subject and text when necessary.

2.7.2 Format of email to be sent

You can send email in text format. Write a message in the mail text or send the text file with a message. If you define both text and text file, the contents of text file take precedence.

Windows can also send attached files.

2.7.3 List of attached files to be sent (Windows only)

When you send attached files, you can create a list of attached files and automatically attach the files in the list to the mail.

Users create the list of attached files in plain text format. The following table shows the format of a list of attached files.

Table 2–13: Format of a list of attached files

Place	Format	Contents
1 st line	<code>Files: <i>number-of-files</i></code>	For <i>number-of-files</i> , write the number of attached files in the second and later lines. If the number of written files exceeds <i>number-of-files</i> , the excessive files are ignored. If the number of written files is smaller than <i>number-of-files</i> , all the files are valid.
2 nd and later lines	<code><i>full-path-name-of-a-file</i></code>	The full path name of an attached file is written in each line.

An example of a list of attached files is shown below.

Figure 2–17: Example of list of attached files

Example format

```
Files:3
C:\USERS\DEFAULT\common\charge-list.xls
C:\USERS\DEFAULT\common\product-explanation.doc
C:\USERS\DEFAULT\customer-A\transaction-history.xls
```

When both the attached file and the attached file list are defined, the contents of the attached file list take precedence and the files in the list are sent.

Cautionary notes

- You can specify a maximum of 20 files in an attached file list.
- Note the following when sending email without using Outlook:
 - The maximum size of attached files depends on the maximum size specified in the mail server settings.
 - We recommend that the total size of file attachments does not exceed 10 megabytes for any single email.
 - If you specify attached files exceeding 10 megabytes, specify a value in the `EmbeddedMailTimeout` parameter (in seconds) of at least the attached file size in megabyte x 2. For details on the `EmbeddedMailTimeout` parameter, see [2.2.2\(1\) Setting environment setting parameters](#).

2.7.4 Cautionary notes on sending email (for a Windows host when not using Outlook)

Note the following when sending email on a Windows host without using Outlook:

Keeping sent items

The mail system linkage function does not retain a local copy of email sent without using Outlook.

Format of recipients in email sending jobs

Recipients of emails sent by email sending jobs must be specified by a standard Internet email address.

How JP1/AJS3 behaves when a domain name is specified incorrectly in an email with multiple recipients

When an email contains a recipient with a domain name (the portion after the @ sign) specified incorrectly, the job enters *Ended abnormally* status and the email is not sent to the recipients whose addresses are specified correctly. Take care to avoid errors when specifying email recipients.

Timeout periods when sending emails

When sending an email via an email sending job, each of the following steps has its own timeout period:

- Waiting for a connection to the mail server
- Waiting for a response from the mail server
- Waiting for the process (`telsmail.exe`) to finish

These periods can be set by environment setting parameters in the definition key `[{JP1_DEFAULT|logical-host-name}\JP1AOMAGENT\mail_link]`.

The following table lists the environment setting parameters that define these timeout periods.

Table 2–14: Environment setting parameters that define timeout periods when sending email without using Outlook

No.	Type of timeout	Environment parameter that defines timeout period	Default
1	Waiting for a connection to the mail server	ConnectTimeout	10 seconds
2	Waiting for a response from the mail server	RecvTimeout	10 seconds
3	Waiting for the process (telmail.exe) to finish	EmbeddedMailTimeout	600 seconds

About attached files

If you send an email without using Outlook, Base64 encoding is applied to any attached files, so the size of the attached files in the email data increases about 1.33 times. As a result, when sending emails with one or more attached files, you need to make sure that the total size of the email data after Base64 encoding does not exceed the maximum value set for the mail server.

2.7.5 Cautionary notes on sending email (for a Windows host when using Outlook)

Note the following when sending email on a Windows host using Outlook:

Deleting sent email

The email sent by the email sending job remains in **Sent Items** of Outlook. This email data might use a large amount of system disk space on the mail server or on the computer where email is sent. Activate Outlook with the profile for the mail system linkage on a regular basis to delete the email remaining in **Sent Items**.

Note that before you delete email from **Sent Items** of Outlook, you must stop the JP1/AJS3 mail monitoring process or the JP1/AJS3 Mail service.

Formats that can be specified as recipients in the email sending job

The following table shows the formats that can be used to specify recipients.

Note that the profile specified for the email sending job must be configured according to the mail system that will be used.

Table 2–15: Formats that can be specified as recipients in the email sending job

Profile type	Format
Exchange Server [#]	<ul style="list-style-type: none"> • Display name • Alias • Internet mail address
Internet Mail (SMTP/POP3)	Internet mail address

#

Email sending jobs cannot send email to addresses in X.400 format.

The following is an example of an X.400-format address:

```
c=JP;p=MailServer;o=Exchange;g=Taro;s=Hitachi;
```

Using single-byte katakana characters in email sending jobs

Do not use single-byte katakana characters in the address, subject line, and message text in an email sending job. Depending on the linked mail system, single-byte katakana characters in the sent email might be converted to multi-byte katakana characters, preventing the contents of the job definition from being applied.

2.7.6 Cautionary note on defining an email sending job

When specifying a body text file, attached file, or attached file list in an email sending job, create a file on a local drive. You cannot use a file on a network drive (a file specified in the `\\computer-name\folder\` format or stored on a drive assigned as a network drive).

3

Adding Custom Jobs

This chapter describes how to add custom jobs.

3.1 Overview of custom jobs

A custom job is a type of job that is defined with the processes to be executed in programs other than JP1/AJS3.

You can define custom jobs in a jobnet in the same way you can define PC jobs and Unix jobs. To use a custom job, you must register the custom job with the Windows version of JP1/AJS3 - View. The registered custom job appears in the icon list in the Jobnet Editor window. You can define the job by dragging and dropping it in the same way as other jobs.

JP1/AJS3 supports two types of custom jobs: default custom jobs and custom PC/Unix jobs. The following subsections describe default custom jobs, custom PC jobs, and custom Unix jobs. Cautionary notes on custom jobs are also provided.

3.1.1 Default custom jobs

JP1/AJS3 provides default custom jobs as standard to link Windows versions of JP1 series products. If you want to link UNIX versions of JP1 series products, register a job as a custom Unix job.

(1) List of default custom jobs

The following table lists default custom jobs.

Table 3–1: List of default custom jobs

Default custom job name	Function
JP1FTP	This job works with JP1/FTP to transfer files.
JP1AMR3, JP1AMR3UX	This job works with JP1/AJS3 for Enterprise Applications to execute the background jobs of the SAP system.
JP1AMR3BW, JP1AMR3BWUX	This job works with JP1/AJS3 for Enterprise Applications to execute the info packages of the BW system.
JP1AMR3CP, JP1AMR3CPUX	This job works with JP1/AJS3 for Enterprise Applications to copy the background jobs of the SAP system.
ADSHPC, ADSHUX, ADSHAPPEXEC	This job works with JP1/Advanced Shell to execute the script file of JP1/Advanced Shell.
DHAJEW	This job works with JP1/DH - AJE to send and receive data to and from JP1/DH - Server.
CPALINK	This job works with JP1/CPA to start a job that has already been registered in JP1/CPA.

(2) Preparation for executing a default custom job

The preparation for executing a default custom job includes installing programs and registering the default custom job. Read the following for details.

- To use a default custom job, you need to install the following two programs:
 - Executable program for executing the default custom job
You need to install the program to be linked in the host containing JP1/AJS3 - Manager or JP1/AJS3 - Agent that executes the default custom job.
 - Definition program for defining the default custom job, which is provided by the program to be linked
If you install the program to be linked in a host different from JP1/AJS3 - View, you need to copy the definition program of the default custom job to the host where JP1/AJS3 - View exists.[#]
[#]: The availability of a definition program of a default custom job depends on the support status of the linked product. For details, see the manual or *Release Notes* for the linked product.

The following figure shows the system configuration when using a default custom job.

Figure 3–1: System configuration when using a default custom job

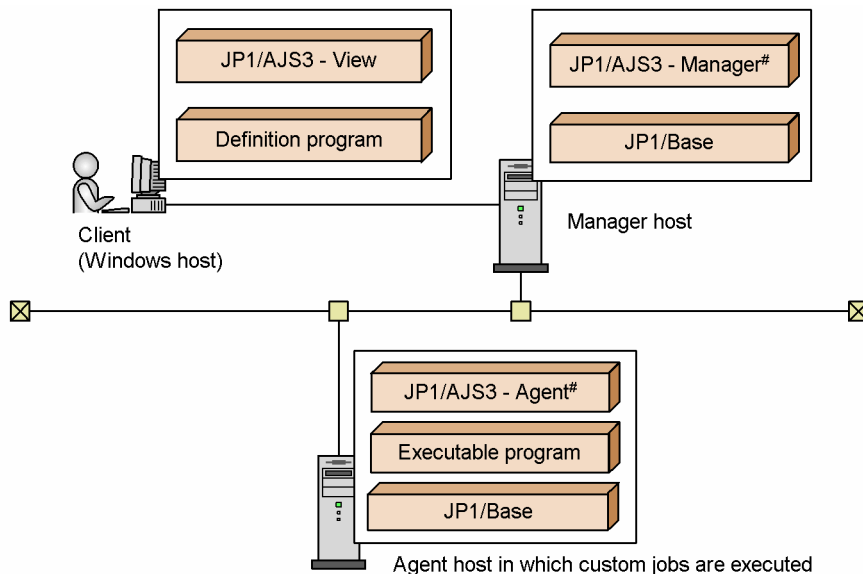

Usually, custom jobs are executed in the agent host. Executing custom jobs in the manager host requires that the executable program be installed in it.

- You need to register the target default custom job.

To display the icons of standard custom jobs in the Jobnet Editor window and Jobnet Monitor window, you need to register the standard custom jobs in each host where JP1/AJS3 - View is installed.

When JP1/AJS3 - View has just been installed, the **Custom Jobs** tab, which displays an icon list, does not appear in the Jobnet Editor window of JP1/AJS3 - View. To add a default custom job icon in the **Custom Jobs** page or display it in the map area in the Jobnet Editor window or the Jobnet Monitor window, you need to register the target default custom job in each host where JP1/AJS3 - View is installed. For details, see [3.2 Registering default custom jobs](#).

Icons for the following default custom jobs are provided with JP1/AJS3.

- For Windows
JP1FTP, JP1AMR3, JP1AMR3BW, JP1AMR3CP, DHAJEW, and CPALINK
- For UNIX
JP1FTP, JP1AMR3, JP1AMR3BW, JP1AMR3CP, JP1AMR3UX, JP1AMR3BWUX, and JP1AMR3CPUX

To obtain the icon for any other job, copy it from the linked program.

3.1.2 Custom PC jobs and custom Unix jobs

You can register a frequently used PC job or Unix job, associating any icon with it. Such jobs are called custom PC jobs or custom Unix jobs.

If you want to link UNIX versions of JP1 series products, use a custom Unix job.

(1) Preparation for executing a custom PC job or a custom Unix job

The preparation for executing a custom PC job or a custom Unix job is registering the target custom PC job or custom Unix job. Read the following for how to register a custom PC job or a custom Unix job.

- You need to prepare a GIF file for an icon.

Prepare a GIF file that represents an icon used to display the custom PC job or custom Unix job in the Jobnet Editor and Jobnet Monitor windows. For details on the format of the GIF file, see [3.3.1 Preparing the gif file for icons](#).

- You need to register the target custom PC job or custom Unix job.

To display the icon of a custom PC or custom Unix job in the Jobnet Editor window or Jobnet Monitor window, you need to register the custom PC or custom Unix job in each host where JP1/AJS3 - View is installed.

When JP1/AJS3 - View has just been installed, the **Custom Jobs** tab, which displays an icon list, does not appear in the Jobnet Editor window of JP1/AJS3 - View. To add a custom PC job icon or a custom Unix job icon in the **Custom Jobs** page or display it in the map area in the Jobnet Editor window or the Jobnet Monitor window, you need to register the target custom PC job or custom Unix job in each host where JP1/AJS3 - View is installed. For details, see [3.3 Registering custom PC jobs or custom Unix jobs](#).

A custom PC job or custom Unix job does not require the installation of an executable program or definition program.

3.2 Registering default custom jobs

To use JP1/AJS3 - View to define default custom jobs for a jobnet, you must register them.

The following shows the procedure for registering a default custom job. Information you specify when registering a job depends on the product you link. For more information, see the documentation for the product to be linked.

To register a custom job:

1. From the Start menu of Windows, choose **JP1_Automatic Job Management System 3 - View**, and then **Register Custom Jobs**.

The Register Custom Job dialog box appears.

2. To register a new custom job, click the **Add** button. To modify an existing custom job, select the custom job you want to modify and then click the **Change** button.

The Set Properties of Custom Job dialog box appears.

3. In this dialog box, specify the custom job name, the executable program, and other necessary items.

For details about the items displayed in the Set Properties of Custom Job dialog box and the items you specify in the Set Properties of Custom Job dialog box, see *12.13.2 Set Properties of Custom Job dialog box* in the *JP1/Automatic Job Management System 3 Operator's Guide*.

4. Click the **OK** button.

The Set Properties of Custom Job dialog box closes.

5. In the Register Custom Job dialog box, click the **Close** button.

The Register Custom Job dialog box closes.

6. In the Jobnet Editor window, click the **Custom Jobs** tab to ensure that the icon of the custom job is added.

The method of defining the custom job into a jobnet is the same as PC jobs and Unix jobs.

Cautionary note

After registering a custom job, always be sure to restart JP1/AJS3 - View. After restarting, the registered information becomes effective.

3.3 Registering custom PC jobs or custom Unix jobs

To use JP1/AJS3 - View to default define custom jobs into a jobnet, you must register them.

To link UNIX versions of JP1 series products, register a job as a custom Unix job. For details of information you specify when linking the UNIX version of a JP1 series product, see the documentation for the product.

Prepare a GIF file for an icon before registering a job.

To register a custom job:

1. From the Start menu of Windows, choose **JP1_Automatic Job Management System 3 - View**, and then **Register Custom Jobs**.

The Register Custom Job dialog box appears.

2. To register a new custom job, click the **Add** button. To modify an existing custom job, select the custom job you want to modify and then click the **Change** button.

The Set Properties of Custom Job dialog box appears.

3. In this dialog box, specify the custom job name, the executable program, and other necessary items.

For details about the items displayed in the Set Properties of Custom Job dialog box and the items you specify in the Set Properties of Custom Job dialog box, see *12.13.2 Set Properties of Custom Job dialog box* in the *JP1/Automatic Job Management System 3 Operator's Guide*.

4. Click the **OK** button.

The Set Properties of Custom Job dialog box closes.

5. In the Register Custom Job dialog box, click the **Close** button.

The Register Custom Job dialog box closes.

6. Store a created or selected icon GIF file in the *JP1/AJS3 - View-installation-folder\image\custom*.

The format of the `gif` file name differs depending on the job type.

For a custom PC job, which will be executed on a Windows host, the icon file name must have the following format:

```
CUSTOM_PC_USER_any-name.gif
```

For a custom Unix job, which will be executed on a UNIX host, the icon file name must have the following format:

```
CUSTOM_UX_USER_any-name.gif
```

The `USER_any-name` portion must match the class name. For details about class names, see *12.13.2 Set Properties of Custom Job dialog box* in the *JP1/Automatic Job Management System 3 Operator's Guide*.

7. In the Jobnet Editor window, click the **Custom Jobs** tab to ensure that the icon of the custom job is added.

The method of defining the custom job into a jobnet is the same as PC jobs and Unix jobs.

3.3.1 Preparing the gif file for icons

This section describes the `gif` file for icons, which is required to register custom PC jobs and custom Unix jobs.

Software to use

Use a graphics editor that can handle graphics in `gif` format.

Icon size

The maximum size of an icon is 32x32 pixels. However, if you create icons with the maximum size of 32x32 pixels, there is no room between the icons in the icon list in the Jobnet Editor window. Therefore, we recommend that you create icons in 30x30-pixel or a smaller area with a margin of at least one pixel placed around the area.

Colors

- The colors indicating the statuses (for example, red for abnormal termination and green for normal termination) are generated by applying an appropriate filter to a base color (RGB values of 255, 102, 255) in the program. Therefore, if you want to indicate the status in a portion of an icon, you must set the base color for the portion.
- For the portions you want to make transparent, use a transparent color.
- Depending on the display settings and the pallet you are using, JP1/AJS3 - View may be unable to correctly display the colors set with the graphics editor. Ensure that the colors you set are displayed correctly in JP1/AJS3 - View.

Supplementary note

For details about drawing (such as setting the RGB values and setting transparent colors), see the documentation for the graphics editor you are using.

3.4 Cautionary notes on custom jobs

Note the following when using custom jobs.

- The Windows version of JP1/AJS3 - View uses jobnet icons to display the custom jobs that are only registered in other JP1/AJS3 - Views. Such an icon can be changed to a question mark (?). For details, see *11.3.11 Displaying unregistered custom jobs with the jobnet icon* in the *JP1/Automatic Job Management System 3 Operator's Guide*.
- After you edit a registered custom job in the Register Custom Job dialog box, check whether the custom job you edited is not defined in the Jobnet Editor window. If the custom job is already defined, delete the custom job and then define it again.
- If a custom job has not been registered correctly, the custom job icon is not displayed. Make sure that the custom job has been registered correctly.

4

Linking JP1/FTP

JP1/FTP is a program that transfers files using the FTP protocol. By linking JP1/FTP, you can automate the transfer of files. This chapter describes how to define a job that uses JP1/FTP as a JP1/AJS3 job.

4.1 Overview of linking JP1/FTP

Linking JP1/FTP enables you to define file transfer as a job in a jobnet. This lets it automate the transfer of files using JP1/AJS3.

To transfer files as a job of a jobnet, you define a JP1/FTP custom job, provided by JP1/AJS3, in a jobnet and execute it.

To run this custom job, JP1/FTP is required both on the host on which you execute it (the host that transmits files) and the host that receives the files.

4.2 Setup for linking JP1/FTP

To define and execute JP1/FTP custom jobs, you must install JP1/FTP on the host where you execute the custom jobs. In addition, to define custom jobs using JP1/AJS3 - View, you have to copy the definition program for JP1/AJS3, which JP1/FTP provides, to the JP1/AJS3 - View host.

The following figure shows an example of a system configuration for linking JP1/FTP.

Figure 4–1: Example of a system configuration for linking JP1/FTP

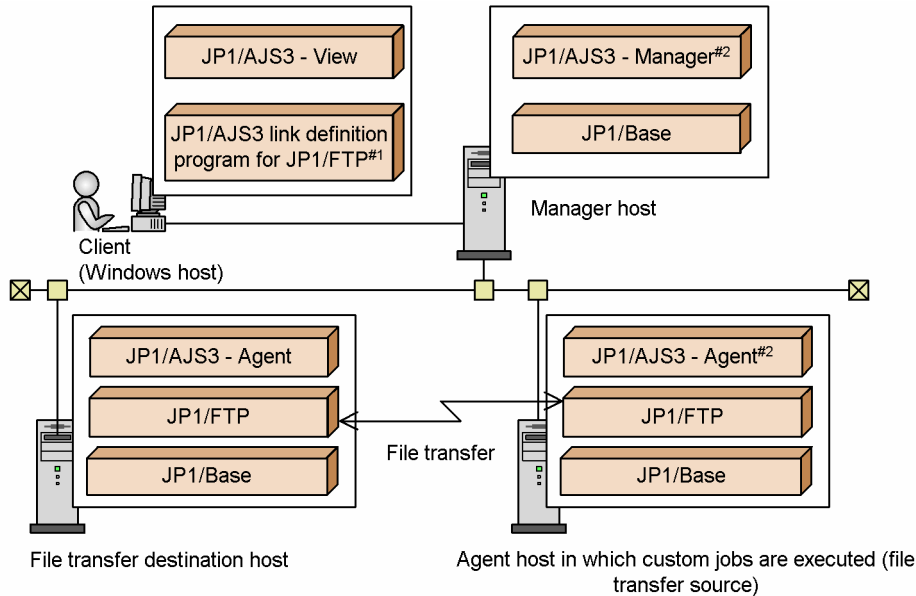

#1 You can install and use JP1/FTP instead of the definition program.

#2 Usually, JP1/FTP custom jobs are executed in the agent host.

Executing JP1/FTP custom jobs in the manager host requires that JP1/FTP be installed in it.

Commands for operating units while using the automatic startup program registration function of JP1/FTP for UNIX require you to start the JP1/FTP daemon by specifying the following environment variables.

- JP1FTS_AUTO_UID_OPTION=TRUE
- JP1FTS_AUTO_STDIO=*standard-I/O-file-name* and *standard-error-output-file-name*

The following example shows how to enter these variables:

```
# JP1FTS_AUTO_UID_OPTION=TRUE
# JP1FTS_AUTO_STDIO=/dev/null
# export JP1FTS_AUTO_UID_OPTION JP1FTS_AUTO_STDIO
# jftsd
```

The figure below shows the setup procedure for linking JP1/FTP.

Figure 4–2: Setup procedure for linking JP1/FTP

(1) Procedure for the Manager host

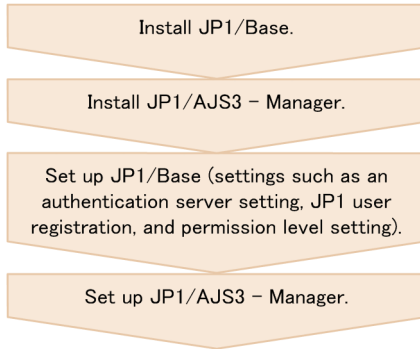

(2) Procedure for the Agent host (in which custom jobs are executed)

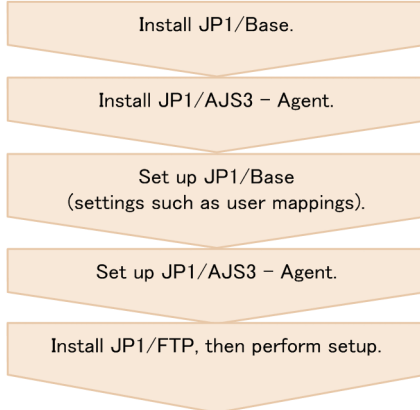

(3) Procedure for the Client

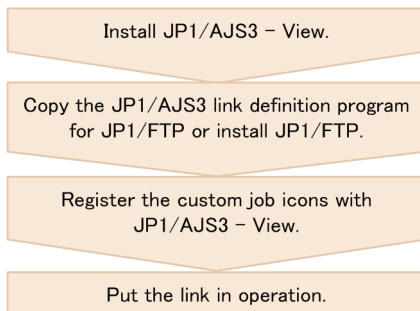

For details on how to register custom job icons, see [3.2 Registering default custom jobs](#).

4.3 Transferring files using JP1/FTP

This section describes procedures for defining a custom job for JP1/FTP in a jobnet.

To define a custom job for JP1/FTP in a jobnet:

1. Open the jobnet to be edited in the Jobnet Editor window.
Open the jobnet and then select the **Exclusive edit** check box.
2. Drag the icon of the custom job for JP1/FTP from the icon list and drop it into the map area.
Dropping the icon causes the Define Details - [Custom Job] dialog box to appear.
3. Define the unit name and other attributes.
4. Click the **Details** button.
The dialog box for specifying the transmission card appears.
5. Define details for the job to be executed and click the **OK** button.
6. Click the **OK** button in the Define Details - [Custom Job] dialog box.

5

Linking ERP Systems

JP1/AJS3 can link ERP systems, such as SAP. By linking ERP systems, you can define ERP processing as JP1/AJS3 jobs. This chapter describes how to define ERP processing as JP1/AJS3 jobs while linked with the ERP system.

5.1 Overview of linking ERP systems

JP1/AJS3 can be used to automate the processing of SAP or similar ERP systems. Using the JP1/AJS3 calendar function or job scheduling function, you can finely schedule and operate ERP system tasks.

Define tasks for the ERP system as ERP system custom jobs in a jobnet. By linking the custom jobs with other jobs, you can execute ERP tasks upon the occurrence of a specified event or automatically execute a recovery unit if an ERP task fails.

JP1/AJS3 can link the following ERP systems:

- SAP system
- SAP BW system

To link JP1/AJS3 with a SAP system or SAP BW system, you need JP1/AJS3 for Enterprise Applications. Install JP1/AJS3 for Enterprise Applications on the same host where JP1/AJS3 - Agent or JP1/AJS3 - Manager is installed to execute custom jobs. JP1/AJS3 for Enterprise Applications is renamed from the JP1/Application Manager for R/3(R) in JP1 Version 6.

5.2 Setup for linking a SAP system or SAP BW system

To define and execute a custom job for a SAP or SAP BW system, you need JP1/AJS3 for Enterprise Applications on the host where you define and execute the custom job. In addition, to define a custom job using JP1/AJS3 - View, you have to copy the definition program for JP1/AJS3, which is provided by JP1/AJS3 for Enterprise Applications, to the JP1/AJS3 - View host.

The following figure shows an example of a system configuration for linking a SAP system.

Figure 5–1: Example of a system configuration for linking a SAP system

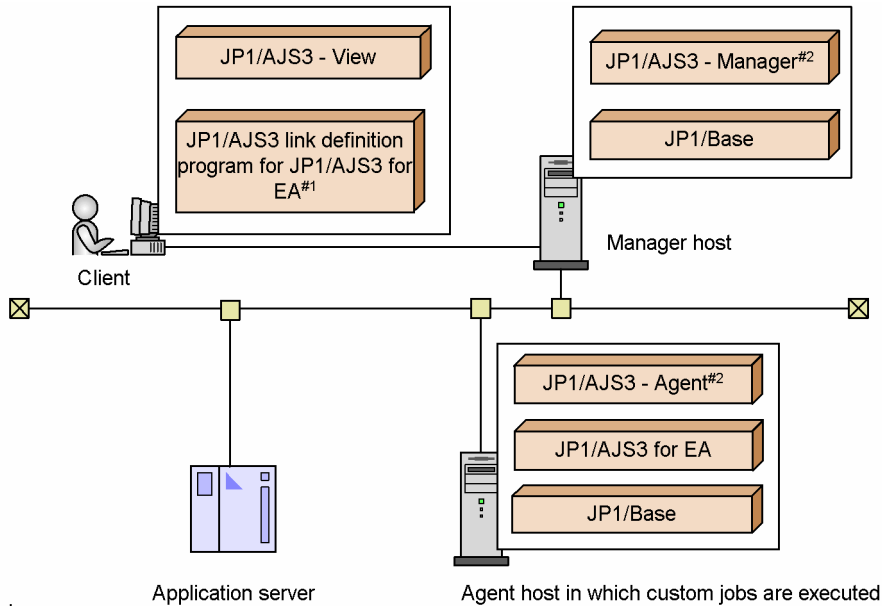

Legend:

JP1/AJS3 for EA: JP1/AJS3 for Enterprise Applications

#1 You can install and use JP1/AJS3 for EA instead of the definition program.

#2 Usually, custom jobs are executed in the agent host.

Executing custom jobs in the manager host requires that JP1/AJS3 for EA be installed in it.

The figure below shows the setup procedure for linking a SAP system.

Figure 5–2: Setup procedure for linking a SAP system

(1) Procedure for the Manager host

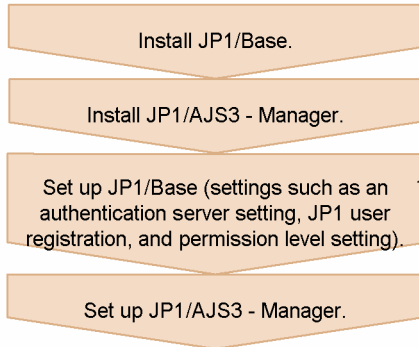

(2) Procedure for the Agent host (in which custom jobs are executed)

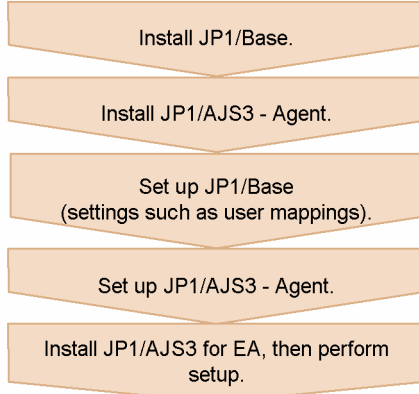

(3) Procedure for the Client

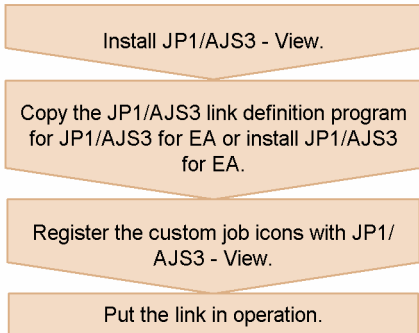

Legend:

JP1/AJS3 for EA : JP1/AJS3 for Enterprise Applications

For details on how to register custom job icons, see [3.2 Registering default custom jobs](#).

5.3 Defining ERP linkage jobs

This section describes procedures for defining a custom job for ERP in a jobnet.

To define a custom job for ERP in a jobnet:

1. Open the jobnet to be edited in the Jobnet Editor window.
Open the jobnet and then select the **Exclusive edit** check box.
2. Drag the custom job icon from the icon list and drop it in the map area.
The icon varies with the ERP system to be linked.
Dropping the icon causes the Define Details - [Custom Job] dialog box to appear.
3. Define the unit name and other attributes.
4. Click the **Details** button.
A dialog box appears to set up details for the job. The displayed dialog box varies with the program to be linked.
For details of information you set up, see the *JP1/Automatic Job Management System 3 for Enterprise Applications Description, User's Guide and Reference*.
5. Define details for the job to be executed and click the **OK** button.
6. Click the **OK** button in the Define Details - [Custom Job] dialog box.

6

Linking Mainframes Using JP1/OJE

This chapter describes how to use JP1/OJE to execute jobs and jobnets on mainframes.

6.1 Overview of linking mainframes using JP1/OJE

You can use JP1/OJE to enter jobs into mainframes (such as VOS3) or receive and execute jobs from mainframes. When you enter jobs from JP1/AJS3 to JP1/OJE, JP1/OJE automatically queues the jobs and executes them. You can check the execution result of the job using JP1/AJS3.

You can use JP1/OJE to link VOS3, AS/400, and other manufacturers' mainframes, including OSIV/MSP.

The following describes how to execute mainframe jobs from JP1/AJS3:

- **QUEUE jobs and submit jobs**

You can use QUEUE jobs and submit jobs to link VOS3, AS/400, and OSIV/MSP.

- **QUEUE jobs**

You can define the job to be executed and the queue for execution in a QUEUE job so that the jobnet can enter the job into the queue controlled by JP1/OJE.

- **Submit jobs**

You can use a job execution command (having a name starting with `j p q`) to directly register the job in the queue.

6.2 Setup for executing QUEUE jobs or submit jobs

This section describes the setup for linking JP1/OJE to execute QUEUE jobs or submit jobs.

The following figure shows an example of a system configuration for linking JP1/OJE.

Figure 6–1: Example of a system configuration for linking JP1/OJE to execute QUEUE jobs or submit jobs

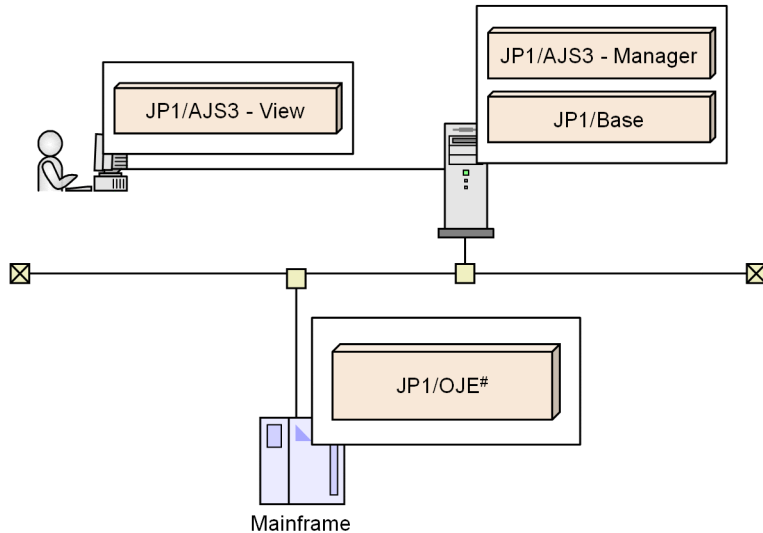

Linking AS/400 requires JP1/OJE for Midrange Computer.

In this example, JP1/AJS3 - Manager linked with JP1/OJE. JP1/AJS3 - Manager can use a QUEUE job or a submit job using a job execution command to issue a job execution request to JP1/OJE.

JP1/AJS3 - Manager can also receive an execution request issued by JP1/OJE.

The figure below shows the setup procedure for linking JP1/OJE.

Figure 6–2: Setup procedure for linking JP1/OJE

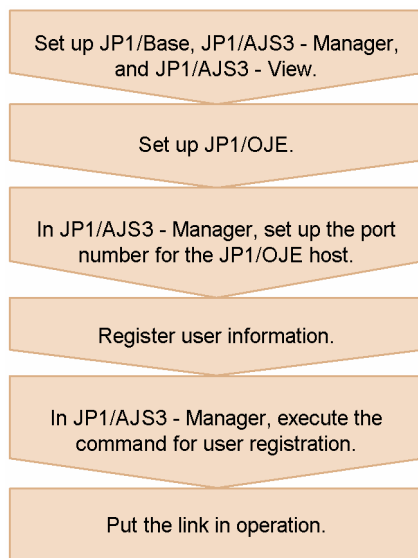

For details about the setup for JP1/OJE, see its manual.

The following subsections describe how to specify the port number and register the user information that are required for linking with JP1/AJS3.

6.2.1 Specifying the port number

Specify the port number for the `jp1ajs2qman` service of JP1/AJS3 - Manager according to the port number used for the linkage with JP1/OJE. The default for the `jp1ajs2qman` service is `20241/tcp`.

To specify the port number, change the `services` file.

6.2.2 Registering user information

You must register the user who issues a job execution request to JP1/OJE and the user who issues a job execution request from JP1/OJE.

The user to be registered varies with how a job is to be executed. (You can execute a job by any of the following three methods: defining a QUEUE job in a jobnet and requesting execution, requesting execution using a submit job, or requesting execution from JP1/OJE to JP1/AJS3). The following describes the registration procedure for each execution method.

(1) Defining QUEUE jobs to request job executions

When jobs are executed by defining QUEUE jobs in a jobnet, the users requesting jobs are JP1 users.

To manage jobs for JP1/OJE, register in advance the mainframe user information for JP1 users in JP1/AJS3 - Manager to which JP1/AJS3 - View logs in.

The following shows the user information you must specify on each host to request execution using QUEUE jobs.

JP1/AJS3 - Manager host

- Register a JP1 user
- Register VOS3 user information

JP1/OJE host

None (mainframe user information applied)

(2) Using submit jobs to request job executions

When jobs are executed by using submit jobs (jobs for which execution is requested using job execution commands beginning with `jpq`), the users requesting jobs are OS users who run the programs that issue these commands.

To manage jobs for JP1/OJE, register the mainframe user information beforehand for the OS users with the host from which executions are requested.

Be sure to type the OS user names accurately with regard to uppercase and lowercase letters. When you request job executions to JP1/AJS3 - Manager, we recommend that you specify the OS user names with all lowercase letters.

The following shows the user information you must specify on each host to request execution using submit jobs.

JP1/AJS3 - Manager host

Register VOS3 user information

JP1/OJE host

None (mainframe user information applied)

(3) Requesting job executions from JP1/OJE to JP1/AJS3

Register users who request job execution as JP1 users with the authentication server in JP1/AJS3 - Manager to which those users request execution. For details about how to register JP1 users, see *3.1.1 Setting up JP1/Base* in the *JP1/Automatic Job Management System 3 Configuration Guide* for a Windows host, or *13.1.1 Setting up JP1/Base* in the *JP1/Automatic Job Management System 3 Configuration Guide* for a UNIX host.

6.2.3 Registering VOS3 user information with JP1/AJS3 (JP1/OJE for VOS3 only)

By using the JP1/AJS3 - Manager from which job handling requests are issued, register the VOS3 user information to convert the JP1 users or OS users to mainframe users or mainframe user groups.

To register user information, execute the `jpqreguser` command in JP1/AJS3 - Manager. For details about the `jpqreguser` command, see *jpqreguser* in *2. Commands Used during Setup* in the manual *JP1/Automatic Job Management System 3 Command Reference*.

6.3 Executing QUEUE jobs or submit jobs

This section describes procedures for executing QUEUE jobs or submit jobs.

To execute QUEUE jobs or submit jobs:

Executing a QUEUE job

1. Open the jobnet to be edited in the Jobnet Editor window.
Open the jobnet and then select the **Exclusive edit** check box.
2. Drag the QUEUE job icon from the icon list and drop it in the map area.
Dropping the icon causes the Define Details - [Queue Job] dialog box to appear.
3. Define the queue name, job name, and other attributes.
The name of the file to be executed must not be omitted.
4. Click the **OK** button.

Executing a submit job

Specify the job to be executed and the queue to be used, and then execute the `jpqjobsub` command. For details about the `jpqjobsub` command, see *jpqjobsub* in *4. Commands Used for Special Operation* in the manual *JP1/Automatic Job Management System 3 Command Reference*.

7

Linking hp NonStop Server (Windows Only)

This chapter describes how to link hp NonStop Server to enter jobs into hp NonStop Server.

7.1 Overview of linking hp NonStop Server

You can link HP NonStop Server to enter jobs into HP NonStop Server or execute jobs received from HP NonStop Server. You can check the execution result of the job using JP1/AJS3.

To enter jobs from JP1/AJS3 to HP NonStop Server, queue the jobs as QUEUE jobs.

You must install the Job scheduler for the MPP JP1 linkage option for HP NonStop Server.

7.2 Setup for linking hp NonStop Server

This section describes the setup for linking HP NonStop Server to execute jobs.

The following figure shows an example of a system configuration for linking HP NonStop Server.

Figure 7–1: Example of a system configuration for linking HP NonStop Server

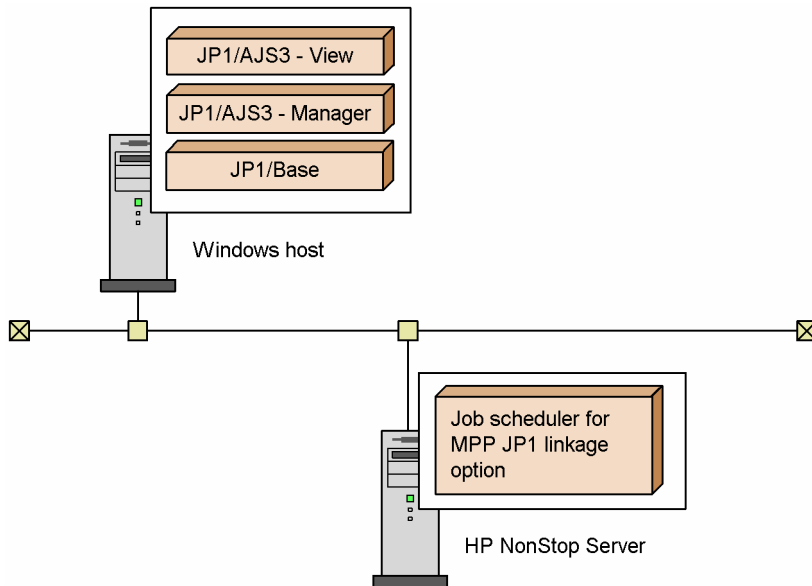

In this example, JP1/AJS3 - Manager is linked with HP NonStop Server.

The figure below shows the setup procedure for linking HP NonStop Server.

Figure 7–2: Setup procedure for linking HP NonStop Server

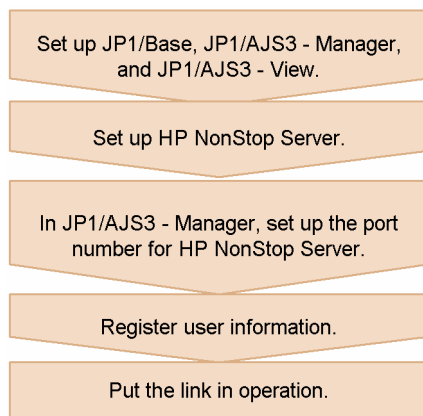

For details about the setup for HP NonStop Server, see the documentation supplied with the HP NonStop Server system.

7.2.1 Specifying the port number

Specify the port number for the `jp1ajs2qman` service of JP1/AJS3 - Manager according to the port number used for the linkage with HP NonStop Server. The default for the `jp1ajs2qman` service is `20241/tcp`.

To specify the port number, change the `services` file.

7.2.2 Registering user information

When issuing a job execution request to HP NonStop Server, you do not need to register the user requesting the job with HP NonStop Server. That is because the user name does not have a meaning during job execution in HP NonStop Server.

When issuing a job execution request from HP NonStop Server to JP1/AJS3, register users who request job execution as JP1 users in the authentication server of JP1/AJS3 - Manager that will receive the job execution request. For details about how to register JP1 users, see *3.1.1 Setting up JP1/Base* in the *JP1/Automatic Job Management System 3 Configuration Guide* for a Windows host, or *13.1.1 Setting up JP1/Base* in the *JP1/Automatic Job Management System 3 Configuration Guide* for a UNIX host.

7.3 Entering jobs into hp NonStop Server

Use QUEUE jobs to enter jobs into HP NonStop Server. This section describes the procedure for using a QUEUE job to enter a job into HP NonStop Server.

To enter a job into HP NonStop Server:

1. Open the jobnet to be edited in the Jobnet Editor window.
Open the jobnet and then select the **Exclusive edit** check box.
2. Drag the QUEUE job icon from the icon list and drop it in the map area.
Dropping the icon causes the Define Details - [Queue Job] dialog box to appear.
3. Define the queue name, job name, and other attributes.
4. Click the **OK** button.

8

Linking JP1/Script

JP1/AJS3 can execute script files you created with JP1/Script. This chapter describes how to define JP1/Script script files as JP1/AJS3 jobs.

8.1 Overview of linking JP1/Script

JP1/AJS3 can define and execute scripts created with JP1/Script version 06-00 or later as jobs.

When you link JP1/Script, you can display the graphical user interface (GUI) from JP1/AJS3 jobs. Usually, a JP1/AJS3 job cannot execute a program that displays the GUI and waits for input. You can, however, start a program using the GUI from a JP1/Script script file so that the GUI operates in the same way as when it is started on the desktop. If you display the GUI from a JP1/AJS3 job without using JP1/Script, the operation is not guaranteed.

Linking JP1/Script may also make jobs that do not use the GUI operable, such as a print job that depends on the logon space.

For details about creating script files, see the manual *JP1/Script Description and Reference*, for Windows Systems.

8.2 Setup for linking JP1/Script

The following figure shows an example of a system configuration for linking JP1/Script.

Figure 8–1: Example of a system configuration for linking JP1/Script

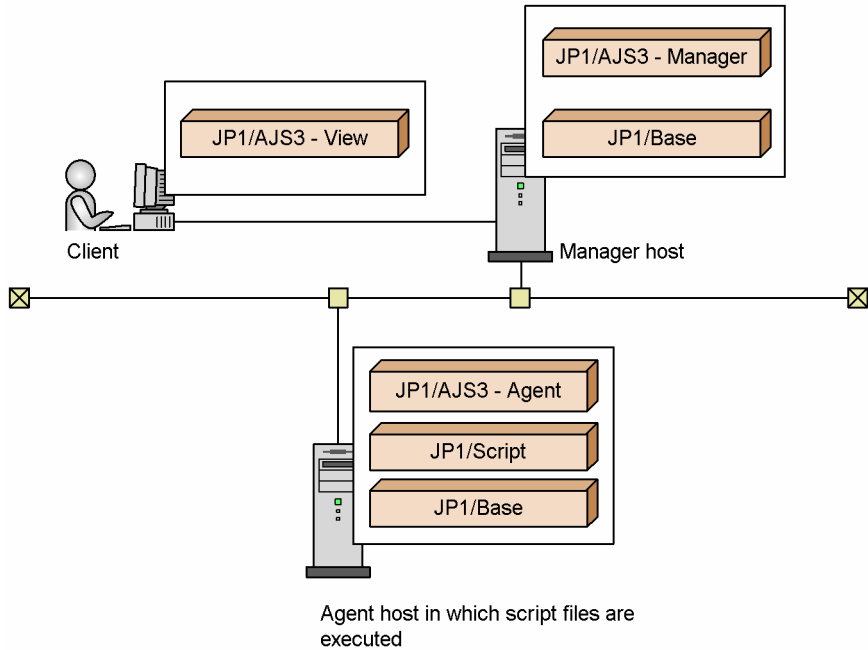

The manager host can define a job for requesting the agent host to execute a script file created by the agent host. This script file is executed when the specified execution time is reached.

For a host to execute a script file, JP1/Script must be installed in the host in advance.

The figure below shows the setup procedure for linking JP1/Script.

Figure 8–2: Setup procedure for linking JP1/Script

(1) Procedure for the Manager host

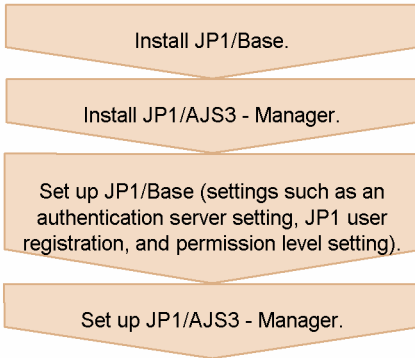

(2) Procedure for the Agent host (in which script files are executed)

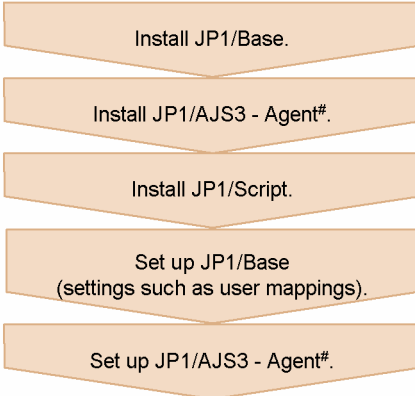

Either JP1/AJS3 - Agent# or JP1/Script can be installed first.

(3) Procedure for the Client

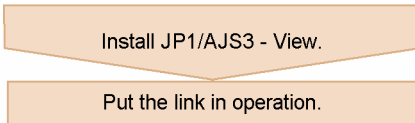

When executing JP1/Script jobs on the Manager host, set up the Manager host in the same way as with the Agent host.

You do not need to set up JP1/Script. JP1/AJS3 does not require a special setup for linking JP1/Script.

8.3 Executing script files

To execute a JP1/Script script file as a job, specify the script file created with JP1/Script in the executable file for a PC job or QUEUE job (PC).

The following shows the procedure for defining a JP1/Script script file as a job in a jobnet.

To define a JP1/Script script file as a job in a jobnet:

1. Open the jobnet to be edited in the Jobnet Editor window.
Open the jobnet and then select the **Exclusive edit** check box.
2. Drag the PC or QUEUE job icon from the icon list and drop it in the map area.
Dropping the icon causes the Define Details dialog box for the dropped job to appear.
3. Specify a JP1/Script script file as the executable file.
4. Click the **OK** button in the Define Details - [PC Job] or Define Details - [Queue Job] dialog box.

9

Monitoring Jobnets Using JP1/IM and JP1/IM2

This chapter describes the following functions: 1) A function that works with JP1/IM to monitor the JP1/AJS3 execution status from JP1/IM - View, 2) a function that works with JP1/IM2 to centrally monitor the statuses of root jobnets managed by multiple managers, and 3) a function that works with JP1/IM2 to display a chain of JP1 events passed across multiple managers. For details on JP1/IM and JP1/IM2, see the *JP1/Integrated Management 3 - Manager Overview and System Design Guide*.

9.1 Overview of monitoring jobnets using JP1/IM and JP1/IM2

You can use JP1/IM to monitor the execution status, including failures, of JP1/AJS3 and jobnets for JP1/AJS3. In addition, you can use JP1/IM2 to collectively monitor the statuses of multiple JP1/AJS3 managers and to display information passed across managers so that you can check the scope of impact when a failure occurs. JP1/IM and JP1/IM2 is a product for the integrated monitoring of JP1 series products and other related programs. You can link JP1/IM or JP1/IM2 with JP1/AJS3 to monitor JP1/AJS3 and other JP1 series products on the same window.

JP1/IM and JP1/IM2 performs monitoring using JP1 events issued by JP1/AJS3.

One method is available for JP1/IM and JP1/IM2 to monitor JP1/AJS3. The following describes how to monitor JP1/AJS3.

- Monitor using JP1 events

9.1.1 Monitoring JP1/AJS3 by using JP1/ IM

This subsection describes how to use JP1/IM to monitor JP1/AJS3.

(1) Monitoring using JP1 events

The JP1 events issued by JP1/AJS3 or other JP1 products are listed in the JP1/IM - View Event Console window. You can modify the display conditions for the Event Console window so that only the JP1 events you are interested in will appear in the list.

If a particular condition in JP1/AJS3 triggers a JP1 event, the event is passed through JP1/Base to JP1/IM - Manager and displayed in the JP1/IM - View Event Console window. You can select a listed JP1 event to display the JP1/AJS3 screen to identify the cause of the event.

For details about the events JP1/AJS3 issues, see *A. JP1 Events Issued by JP1/AJS3* in the *JP1/Automatic Job Management System 3 Administration Guide*.

This example describes how JP1/IM is used to monitor messages, output to the Hitachi integrated trace log and syslog, about errors that occurred on the JP1/AJS3 manager host and agent host.

A description of the numbered steps in the figure, from detection of an error to troubleshooting, follows.

Figure 9–1: Example of error detection using JP1/IM

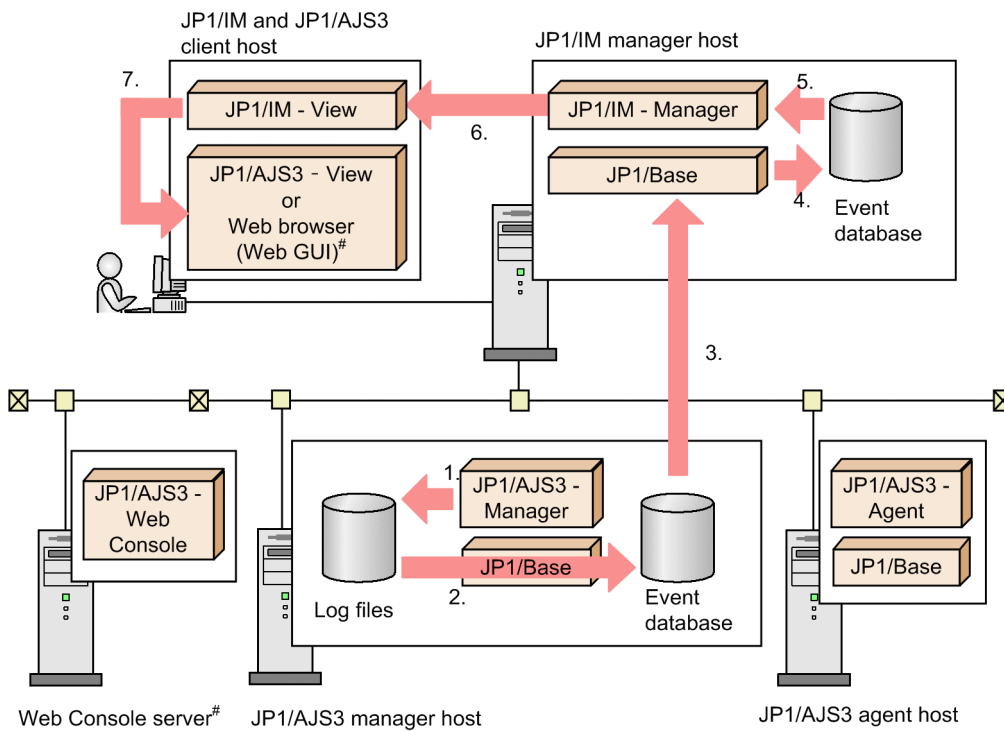

This procedure is unnecessary if Web GUI is not used.

1. An event such as an error occurred in JP1/AJS3 and a message was output to a log, such as the Hitachi integrated trace log.
2. JP1/Base, which uses log trapping (for Error- and Warning-level messages) to monitor the Hitachi integrated trace log and syslog, detected the message, and registers a JP1 event in the event DB.
3. The registered JP1 event is forwarded to the manager host that runs JP1/IM.
4. The received JP1 event is registered in the event DB.
5. JP1/IM acquires the JP1 event from the event DB.
6. The acquired JP1 event is displayed in JP1/IM - View, which notifies the user that a failure occurred on an agent host.
7. If user action, such as re-executing a unit, is required, the user starts JP1/AJS3 - View or Web GUI (Job Portal).

! Important

When you use JP1/IM, a large number of JP1 events might be output from the JP1/AJS3 manager host and agent host. If an excessive number of JP1 events are output, for example, consider using the filtering of events from JP1/Base to JP1/IM to stop forwarding the JP1 events issued by JP1/AJS3 itself.

(2) Other features supported by JP1/IM

In addition to the features described above, JP1/IM supports the following features:

- Calling the JP1/AJS3 - View or Web GUI (Job Portal)
While you are monitoring JP1/AJS3 from the JP1/IM - View window, you can call JP1/AJS3 - View or Web GUI (Job Portal) to redefine jobnets, or to check or temporarily change the execution schedule.
 - From Tool Launcher window of JP1/IM - View, you can display the JP1/AJS3 - View window.

- By specifying a particular JP1 event and clicking the **Monitor** button in the Event Console window of JP1/IM - View, you can open a screen that displays the unit related to the specified JP1 event.
Either of the following screens is displayed:
 - Jobnet Monitor window of JP1/AJS3 - View
 - Monitor screen of Web GUI (Job Portal)
- In the **Guide** area in the Event Details window of JP1/IM - View, you can display a hyperlink for opening the Monitor screen of Web GUI (Job Portal). Clicking the hyperlink displays the Monitor dialog box for the unit related to an issued JP1 event.
- Calling Web GUI (Job Portal) from an email sent by an automated action
The URL of the Monitor screen of Web GUI (Job Portal) can be included in an email that is sent by an automated action of JP1/IM. If you receive an email automatically sent when a failure occurred, you can use the URL to directly open the Monitor screen for the unit for which the failure occurred.
- Monitoring events and files output by JP1/AJS3
JP1/AJS3 itself cannot monitor events and files it outputs. Therefore, use JP1/IM to monitor events and files output by JP1/AJS3 and execute jobs automatically.

9.1.2 Monitoring JP1/AJS3 by using JP1/IM2

This subsection describes how to use JP1/IM2 to monitor JP1/AJS3.

For details about JP1/IM2, see the *JP1/Integrated Management 3 - Manager Overview and System Design Guide*.

(1) Monitoring the statuses of root jobnets managed by multiple instances of JP1/AJS3 - Manager

You can obtain jobnet information from multiple instances of JP1/AJS3 - Manager that are managed by JP1/IM2 to monitor their statuses on one screen. The status of a jobnet that was started by a manager host is updated by a JP1 event issued when the jobnet terminates.

The following figure shows an overview of the processing to update a jobnet status.

Figure 9–2: Overview of the processing to update a jobnet status

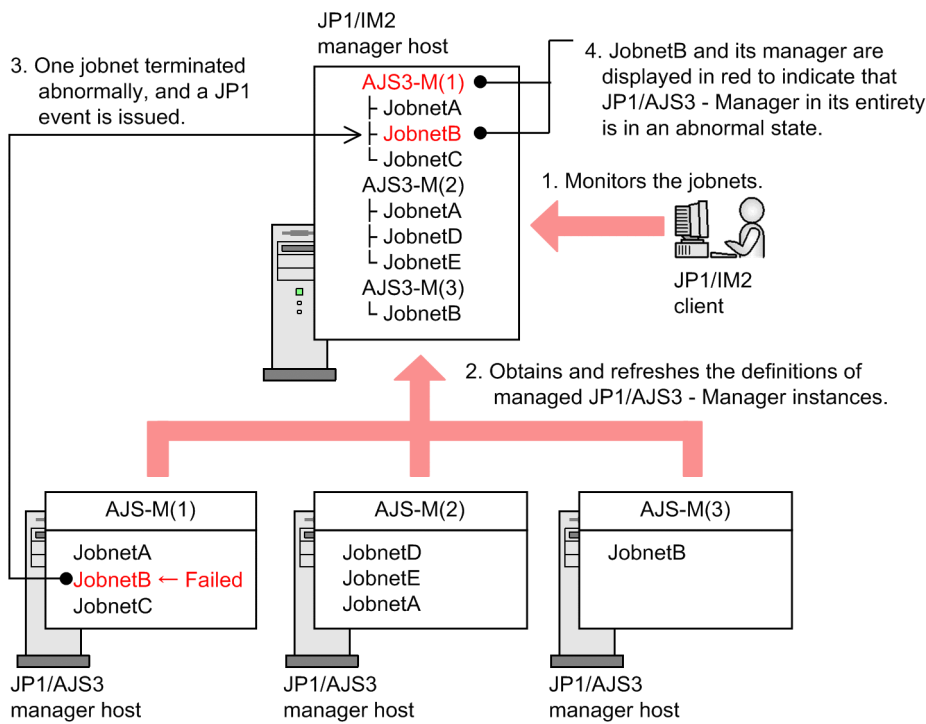

(2) Supporting determination of business impact

The Job flow tab of JP1/IM2 allows you to check links between jobnets. You can also check links between jobnets that are managed by multiple JP1/AJS3 - Manager instances. If an error is detected in a root jobnet, you can use this function to quickly check the impact, such as the scheduled start time of the succeeding job and whether the succeeding job is affected. This allows you to cope with failures in appropriate priority.

The following figure shows an overview of monitoring the status and links between jobnets managed by multiple JP1/AJS3 - Manager instances.

Figure 9–3: Monitoring the status and links between jobnets managed by multiple JP1/AJS3 - Manager instances

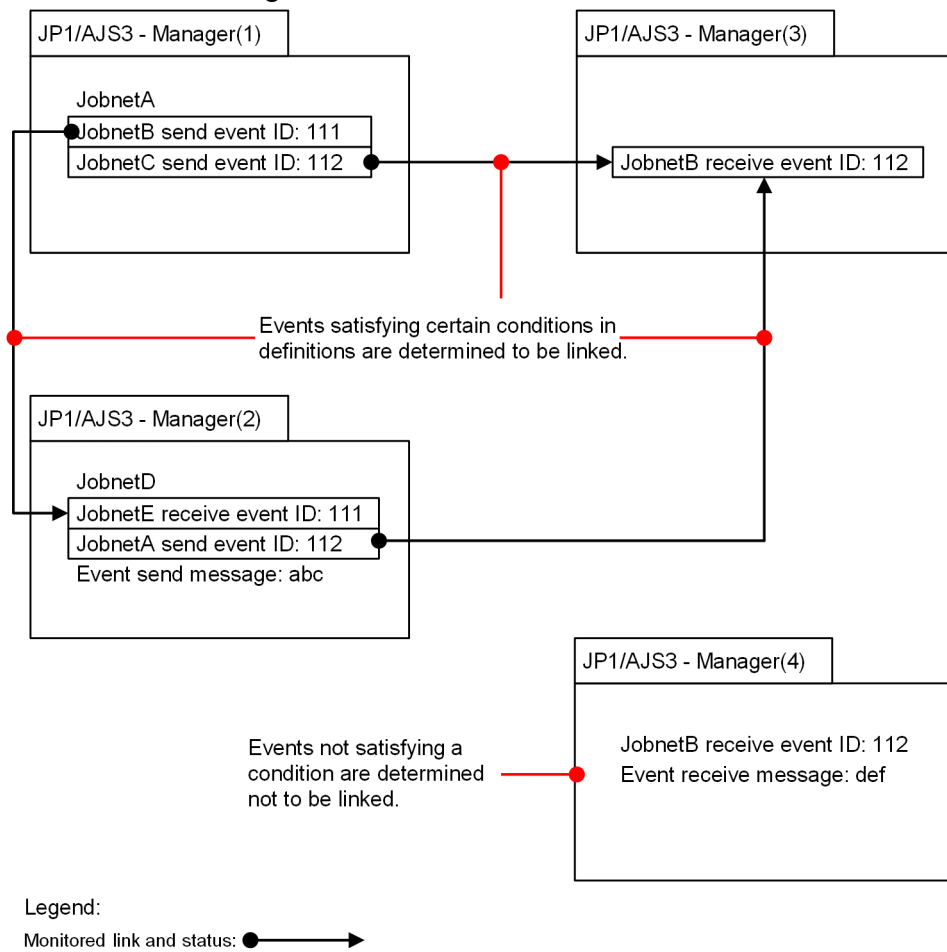

You can monitor units that have the following links:

- Links with JP1 events
- Links with wait conditions
- Links with jobnet connectors

In addition, clicking an icon in the **Job flow** tab opens the **Linked unit** dialog box. If a failure occurs in the preceding unit, you can use this dialog box to check the affected succeeding unit and understand the urgency of corrective actions for each unit job based on the scheduled time. You can also display the Monitor screen of Web GUI (Job Portal) by clicking the preceding or succeeding unit name. This allows you to check details about jobnets in each unit. The **Monitor** screen also allows you to change the wait statuses of units.

The following figure shows an overview of monitoring jobnet details by using the **Linked unit** dialog box.

Figure 9–4: Monitoring jobnet details by using the Linked unit dialog box

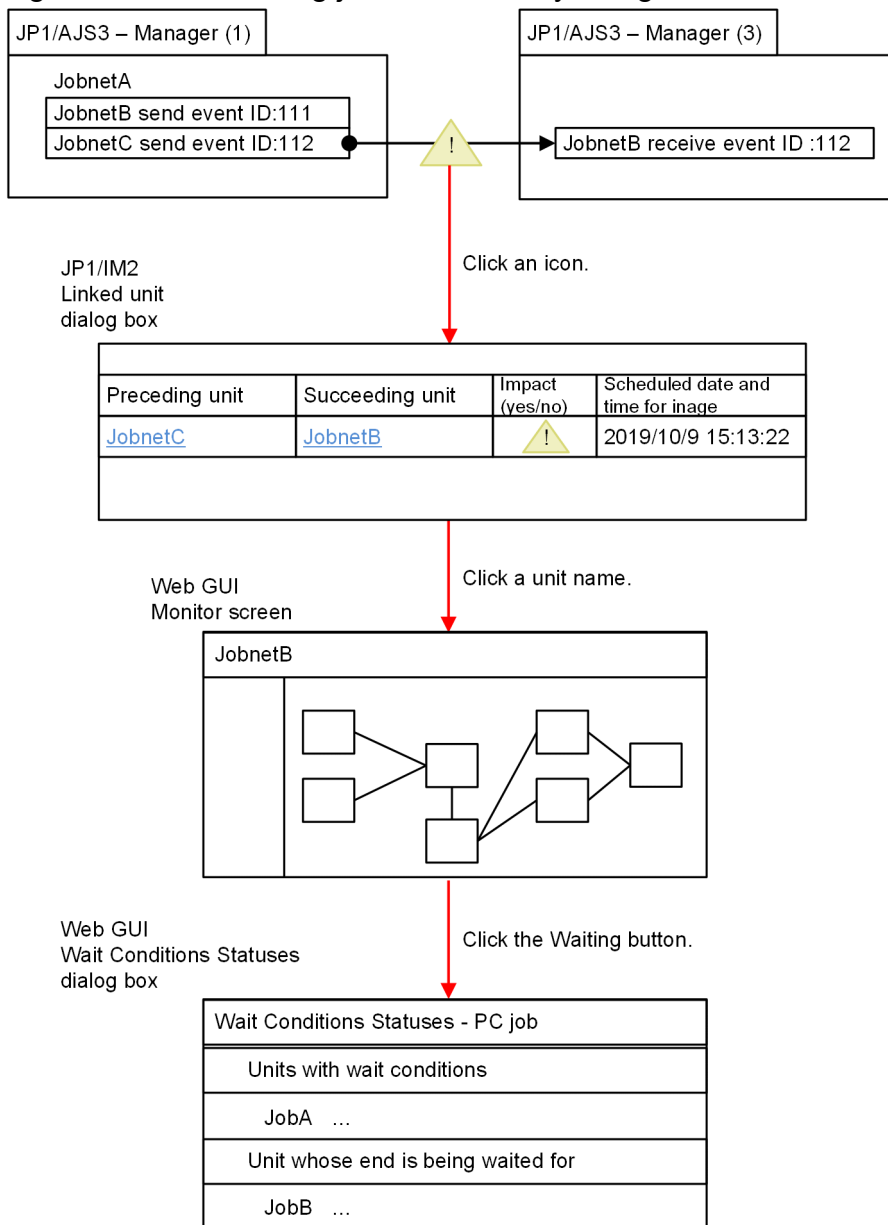

Cautionary note

To monitor wait-related links as described in *Supporting determination of business impact*, operate the system so that, for one root jobnet, the number of generations for a day does not exceed 1,000. The schedule dates and times related to the succeeding units of the 1,000th or later generations will not be displayed.

(3) Proactive monitoring

JP1/AJS3 issues a JP1 event to report that a factor that might stop job execution occurred. Early detection of such factors is possible by checking JP1 events from JP1/IM2. In addition, all performance data collected by JP1/AJS3 in performance reports is displayed as trend information in graphics format in JP1/IM2. This allows you to use trend information to check the operation status of the scheduler service and isolate the cause of any failure. This function is called proactive monitoring.

The following figure shows an overview of proactive monitoring.

Figure 9–5: Overview of proactive monitoring

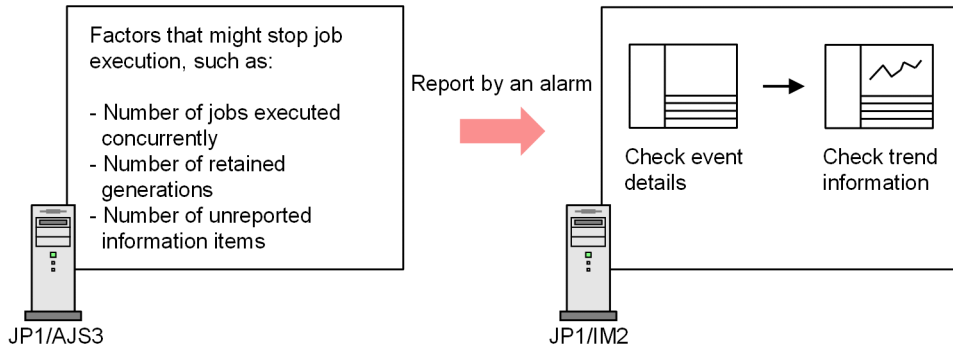

To perform proactive monitoring, the following settings are required:

- Settings for detecting factors that might stop job execution
- Settings for the performance report output function

For details about how to specify the settings for detecting factors that might stop job execution, see *21.7 Settings for detecting factors that might stop job execution* in the *JP1/Automatic Job Management System 3 Configuration Guide*.

For details about how to set the performance report output function, see *6.6 Settings related to the output of performance reports* in the *JP1/Automatic Job Management System 3 Configuration Guide* (in Windows) or *15.7 Settings related to the output of performance reports* in the *JP1/Automatic Job Management System 3 Configuration Guide* (in UNIX).

(4) Other features supported by JP1/IM2

The following describes other features supported by JP1/IM2.

(a) Displaying related node

By linking JP1/AJS3 and JP1/IM2, you can display the relation between root jobnets. You can also check the relation between a root jobnet and execution-target agent, and the relation between JP1/AJS3 - Manager and agent host.

You can display related IM management nodes from the IM management node selected as the starting point in the Integrated Operation Viewer window of JP1/IM2.

(b) Calling Web GUI (Job Portal)

You can call Web GUI (Job Portal) from JP1/IM2 that is monitoring JP1/AJS3. You can use the following methods to display Web GUI (Job Portal) screens.

- In the **Operating status** area in sunburst chart or tree chart format, select a node, and then click the URL of JP1/AJS3 - Web Console displayed in the property information. The Dashboard screen, List screen or Execution Agent screen of Web GUI (Job Portal) is displayed. If the Execution Agent screen was displayed from an agent host node, the execution agent list is filtered by the host name of the node that was selected in JP1/IM2.
- In the event list in the Integrated Operation Viewer window, click **Monitor** from the menu. The Monitor screen of Web GUI (Job Portal) is displayed.

9.2 Setup for linking JP1/IM

The following figure shows an example of a system configuration for linking with JP1/IM.

Figure 9–6: Example of a system configuration for linking with JP1/IM

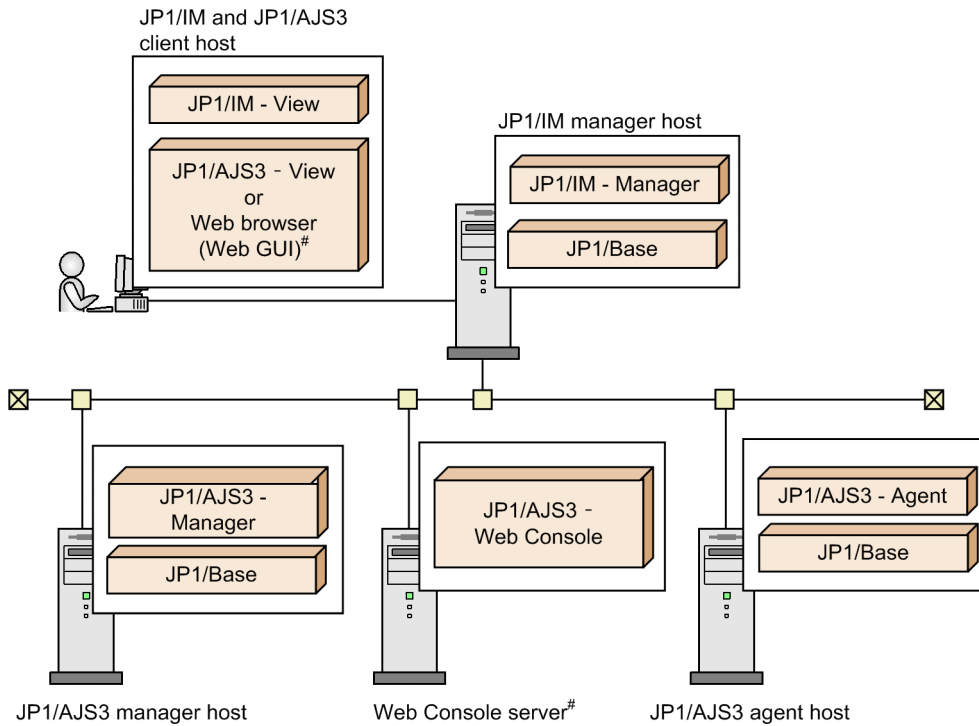

This procedure is unnecessary if Web GUI is not used.

To monitor the JP1/AJS3 status with an icon, JP1/IM - Manager is required.

In this example, events issued by JP1/AJS3 - Manager and JP1/AJS3 - Agent are passed through JP1/Base to JP1/IM - Manager. When JP1/IM - View logs in to JP1/IM - Manager, you can display the JP1 events collected in the manager in JP1/IM - View.

To call JP1/AJS3 - View from JP1/IM - View, install JP1/AJS3 - View and JP1/IM - View on the same host.

The following figure shows the setup procedures for linking JP1/IM - Console.

Figure 9–7: Setup procedures for linking JP1/IM

(1) Procedure for the JP1/IM manager host

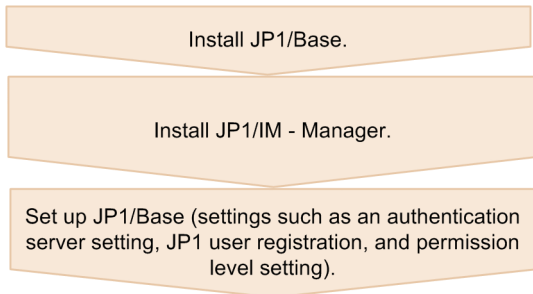

(2) Procedure for the JP1/AJS3 manager host

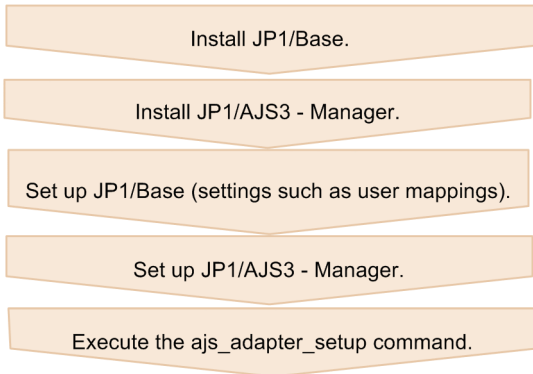

(3) Procedure for the JP1/AJS3 agent host

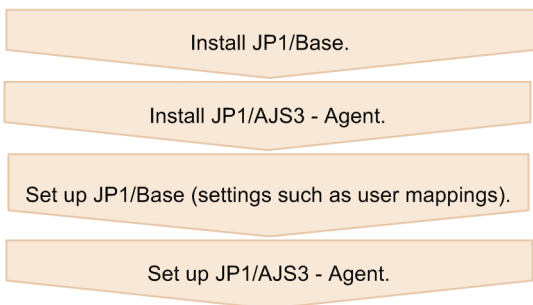

(4) Procedure for the Web Console server^{#1}

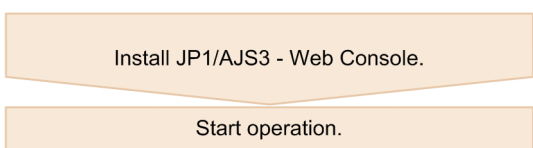

(5) Procedure for the JP1/IM and JP1/AJS3 client host

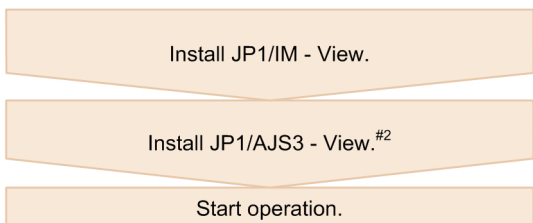

#1 This procedure is unnecessary if Web GUI is not used.

#2 This procedure is unnecessary if Web GUI is used.

To monitor the status of JP1/AJS3 by using icons, execute the `ajs_adapter_setup` command from the JP1/AJS3 manager host. This operation is required to enable JP1/IM to collect the JP1/AJS3 definition information. Use the following format to execute the `ajs_adapter_setup` command:

```
ajs_adapter_setup -i
```

To stop linkage with JP1/IM, execute `ajs_adapter_setup -u` command.

9.2.1 Setup for displaying the job that has output the JP1 event in the Jobnet Monitor

When you call the Jobnet Monitor window from JP1/IM - View to display the jobnets related to the issued JP1 event, the window displays the root jobnet to which the job causing the JP1 event belongs, by default. If the relevant job exists in a nested jobnet, you must perform the following procedure to display that nested jobnet.

- Changing the definition file for opening monitor windows
- Setting options for JP1/AJS3 - View

(1) Changing the definition file for opening monitor windows

Change the definition file for opening monitor windows, stored on the JP1/IM manager host, to the file supplied with JP1/AJS3 - View. To change this value:

Cautionary note

If you perform the setup described here on a JP1/IM manager host, the Jobnet Monitor window of JP1/AJS3 - View is displayed on all JP1/IM clients that are connected to the JP1/IM manager host. Note that this might confuse the users if operation based on Web GUI (Job Portal) has already started.

1. Terminate JP1/IM - View, if running.
2. Change the extension of the definition file for opening monitor windows and back up the file.
Change the extension of the following file:

- In Windows
`system-drive:\Program Files#\HITACHI\JP1Cons\conf\console\monitor\hitachi_jp1_ajs2_mon.conf`
or
`shared-folder\jp1cons\conf\console\monitor\hitachi_jp1_ajs2_mon.conf`
- In UNIX
`/etc/opt/jp1cons/conf/console/monitor/hitachi_jp1_ajs2_mon.conf`
or
`shared-directory/jp1cons/conf/console/monitor/hitachi_jp1_ajs2_mon.conf`

The following example shows how to change the extension of the file.

Before the change: `hitachi_jp1_ajs2_mon.conf`

After the change: `hitachi_jp1_ajs2_mon.conf.bak`

3. Copy the definition file for opening monitor windows from the JP1/AJS3 - View host to the JP1/IM host.
Copy the following file:

```
JP1/AJS3 - View-installation-folder\Conf\hitachi_jp1_ajs2_mon.conf.0700
```

4. Rename the file you have copied in step 3.

Before the change: hitachi_jp1_ajs2_mon.conf.0700

After the change: hitachi_jp1_ajs2_mon.conf

5. Restart the JP1/IM - Manager service.

#

For 64-bit versions of Windows, replace Program Files with Program Files (x86).

(2) Setting options for JP1/AJS3 - View

Specify the following option in the ajs2view_opt.conf file:

```
jajsExecJobnetMonitorAllJobName=Yes
```

For details about customizing the ajs2view_opt.conf file, see *11.1.1 Types of customization methods* in the *JP1/Automatic Job Management System 3 Operator's Guide*.

9.2.2 Setup for displaying Web GUI (Job Portal) from the Event Console window of JP1/IM - View

The default screen displayed when JP1/AJS3 is started by clicking the **Monitor** button in the Event Console window of JP1/IM - View is the Jobnet Monitor window of JP1/AJS3 - View. However, you can change the displayed screen to the Monitor screen of Web GUI (Job Portal) by changing the definition file for opening monitor windows.

Cautionary note

If you perform the setup described here on a JP1/IM manager host, the Monitor screen of Web GUI (Job Portal) is displayed on all JP1/IM clients that are connected to the JP1/IM manager host. Note that this might confuse the users if operation based on JP1/AJS3 - View has already started.

To change the definition file for opening monitor windows, use a model file provided by JP1/AJS3 - Web Console. You can select one of two model files.

- To use HTTPS communication, use the following model file:

```
hitachi_jp1_ajs2_mon_ssl.conf.model
```

- To use HTTP communication, use the following model file:

```
hitachi_jp1_ajs2_mon.conf.model
```

The following is the procedure for changing the definition file for opening monitor windows to a file provided by JP1/AJS3 - Web Console.

1. On all client hosts, terminate JP1/IM - View.
2. On the JP1/IM manager host, rename the definition file for opening monitor windows as a backup file.

Rename the following file:

- In Windows

system-drive: \Program
Files^{#1}\HITACHI\JP1Cons\conf\console\monitor\hitachi_jp1_ajs2_mon.conf^{#2}
or

shared-folder\jp1cons\conf\console\monitor\hitachi_jp1_ajs2_mon.conf^{#2}

- In UNIX

/etc/opt/jp1cons/conf/console/monitor/hitachi_jp1_ajs2_mon.conf^{#2}
or

shared-directory/jp1cons/conf/console/monitor/hitachi_jp1_ajs2_mon.conf^{#2}

#1

For 64-bit versions of Windows, replace Program Files with Program Files (x86).

#2

If the version of JP1/IM - Manager is earlier than 10-00, change the file name to hitachi_jp1_ajs2_mon_ja.conf (for the Japanese version of JP1/IM) or hitachi_jp1_ajs2_mon_en.conf (for the English version of JP1/IM).

3. From the Web Console server, copy the model file of the definition file for opening monitor windows to the JP1/IM manager host.

Copy the following file:

Communication method to be used	OS of the Web Console server	
	Windows	UNIX
HTTPS communication	<i>JP1/AJS3 - Web Console-installation-folder</i> \conf\hitachi_jp1_ajs2_mon_ssl.conf.model	/etc/opt/jplajs3web/conf/hitachi_jp1_ajs2_mon_ssl.conf.model
HTTP communication	<i>JP1/AJS3 - Web Console-installation-folder</i> \conf\hitachi_jp1_ajs2_mon.model	/etc/opt/jplajs3web/conf/hitachi_jp1_ajs2_mon.conf.model

4. Rename the model file you have copied.

On the JP1/IM manager host, rename the copied model file to hitachi_jp1_ajs2_mon.conf so that the model file becomes the new definition file for opening monitor windows. However, if the version of JP1/IM - Manager is earlier than 10-00, change the file name of the copied file to hitachi_jp1_ajs2_mon_ja.conf (for the Japanese version of JP1/IM) or hitachi_jp1_ajs2_mon_en.conf (for the English version of JP1/IM).

5. Open the definition file for opening monitor windows with a text editor, and edit the file.

The name of the host on which JP1/AJS3 - Web Console is installed is set as the host name of the Web Console server in the definition file for opening monitor windows. If you change the host name, use a different name, or change the default port number, you will need to edit the definition file for opening monitor windows.

In the definition file for opening monitor windows, change the Web Console server's host name and port number in the URL set for the PATH entry according to your environment.

6. Restart the JP1/IM - Manager service.

9.2.3 Setup for displaying a hyperlink to Web GUI (Job Portal) in the Event Details window of JP1/IM - View

A hyperlink to the Monitor screen of Web GUI (Job Portal) can be displayed in the Event Details window of JP1/IM - View. By opening the Monitor screen of Web GUI (Job Portal) from the Event Details window, the user can quickly check the status of the unit related to an issued JP1 event.

For details about the event guide function, see the *JP1/Integrated Management 3 - Manager Overview and System Design Guide*.

Before you can change the display of the Event Details window, you must set up the event guide function. To set up the event guide function, edit the following two files:

- Event-guide message file
File in which to write a message to be displayed in the Event Details window.
In an event guide message file, you can specify the message to be output for a JP1 event that occurs, and the URL for opening the Monitor screen of Web GUI (Job Portal).
- Event guide information file
A file managed by JP1/IM - Manager. This file contains the information about the mapping between JP1 events occurring in JP1/AJS3 and event guide message files.

The following is the procedure for setting up the event guide function by editing the above two files.

1. On all client hosts, terminate JP1/IM - View.
2. Create an event-guide message file.
Create (in HTML) a message to be displayed in the Event Details window. An example of an event-guide message file is as follows:

```
<HTML>
<HEAD>
</HEAD>
<BODY>
  A job terminated abnormally.<BR>
  <A HREF="URL-for-opening-the-Monitor-screen">Open the Monitor screen o
f Web GUI (Job Portal).</A>
</BODY>
</HTML>
```

You can specify one of the following two types of URLs as the URL for opening the Monitor screen:

URL supporting single sign-on (JP1/IM - Manager 11-10 or later):

If this type of URL is specified, the user can directly open the Monitor screen of Web GUI (Job Portal) from the Event Details window. The user logs in to JP1/AJS3 with a login account of JP1/IM.

This type of URL has the following format:

```
communication-protocol: //host-name-or-IP-address-of-Web-Console-server:port-number/ajs/
login.html?sign=jt
```

URL not supporting single sign-on (JP1/IM - Manager 09-50 or later):

If this type of URL is specified, the Web GUI (Job Portal) login screen opens first. To open the Monitor screen of Web GUI (Job Portal), the user must log in to JP1/AJS3.

This type of URL is formatted as follows (Δ indicates a one-byte space.):

```
communication-protocol: //host-name-or-IP-address-of-Web-Console-server:port-number/ajs/
login.html?
```

```
manager=$B.SOURCESERVER$URLENC
```

```
Δ&type=monitor&unitName=$E.OBJECT_NAME$URLENCΔ&execID=$E.A3$URLENCΔ&eou=1
```

In the following part, specify values appropriate for your environment:

communication-protocol: //host-name-or-IP-address-of-Web-Console-server:port-number

communication-protocol

Specify http or https as the communication protocol.

host-name-or-IP-address-of-Web-Console-server

Specify the host name or IP address of the Web Console server.

port-number

Specify the port number to be used for communication with the Web Console server. If SSL communication is disabled, the default port number is 22252. If SSL communication is enabled, the default port number is 22253.

The following shows an example of the URL that can be specified:

```
https://hostA:22253/ajs/login.html?sign=jt
```

3. Place the created event-guide message file in any path on the JP1/IM - Manager host.

4. Create the event guide information file.

You can omit this step if you have already created the event guide information file.

For details about the event guide information file, see the manual *JP1/Integrated Management 3 - Manager Command, Definition File and API Reference*.

The following shows the storage folders for the event guide information file.

- In Windows

```
system-drive:\Program Files#\HITACHI\JP1Cons\conf\guide\jco_guide.txt
```

or

```
shared-folder\jplcons\conf\guide\jco_guide.txt
```

- In UNIX

```
/etc/opt/jplcons/conf/guide/jco_guide.txt
```

or

```
shared-directory/jplcons/conf/guide/jco_guide.txt
```

#

For 64-bit versions of Windows, replace Program Files with Program Files (x86).

5. Edit the event guide information file to map JP1 events that can occur in JP1/AJS3 to event-guide message files.

Add the following entry (or substitute it for the existing description) in the event guide information file. You can add multiple entries of the event guide information.

For details and cautionary notes about the event guide information file, see the manual *JP1/Integrated Management 3 - Manager Command, Definition File and API Reference*.

```
DESC_VERSION=file-version
```

```
[EV_GUIDE_event-guide-number]
```

```
EV_COMP=B.IDBASE:event-ID
```

```
EV_COMP=E.PRODUCT_NAME:/HITACHI/JP1/AJS2
```

```
EV_FILE=location-of-the-event-guide-message-file
```

```
[END]
```

The following describes the value to be specified for each entry. Specify a value appropriate for your environment.

file-version

Specify 2.

event-guide-number

Specify a unique number.

event-ID

Specify the ID of a JP1 event to be mapped to an event-guide message file. For the JP1 events that can be specified, see [9.2.5 JP1 events supported by JP1/IM linkage](#).

location-of-the-event-guide-message-file

Specify the path that you specified in step 3.

The following shows an example of entries to be added to the event guide information file:

```
DESC_VERSION=2

[EV_GUIDE_1]
EV_COMP=B.IDBASE:00004102
EV_COMP=E.PRODUCT_NAME:/HITACHI/JP1/AJS2
EV_FILE=C:\\Program Files\\HITACHI\\JP1Cons\\conf\\guide\\guidemes01_Webcon.htm
[END]
[EV_GUIDE_2]
EV_COMP=B.IDBASE:00004103
EV_COMP=E.PRODUCT_NAME:/HITACHI/JP1/AJS2
EV_FILE=C:\\Program Files\\HITACHI\\JP1Cons\\conf\\guide\\guidemes02_Webcon.htm
[END]
```

6. Restart the JP1/IM - Manager service, or execute the `jco_spmc_reload` command.

Cautionary note

The maximum length of a URL that can be used as a hyperlink for an event guide in HTML format is 2,046 characters. For details on how to change the maximum length of a URL, see the Release Notes for JP1/IM.

9.2.4 Setup for displaying a Web GUI (Job Portal) URL in emails sent by automated actions of JP1/IM

You can include the URL of the Monitor screen of Web GUI (Job Portal) in emails sent by automated actions of JP1/IM. To change the settings for emails sent by automated actions, perform the following operations. For details, see the *JP1/Integrated Management 3 - Manager Configuration Guide*.

- Setting up an execution environment for the automated action function
- Setting the execution conditions and details of automated actions

For details about the IDs of JP1 events that can be specified in the definitions of automated actions, see [9.2.5 JP1 events supported by JP1/IM linkage](#).

- Setting email transmissions

Specify the URL for opening the Monitor screen of Web GUI (Job Portal) in the email body.

You can specify a URL in the following format:

```
communication-protocol://host-name-or-IP-address-of-Web-Console-server:port-number/ajs/login.html?manager=$EVHOST$URLENC#&type=monitor&unitName=$EV"OBJECT_NAME"$URLENC#&execID=$EV"A3"$URLENC#&eou=1
```

The variables \$EVHOST\$URLENC, \$EV"OBJECT_NAME"\$URLENC, and \$EV"A3"\$URLENC can be specified only in the command line for automated actions. You need to specify these variables as arguments in a script when you call the script from the command line, and write an email sending command and email text in the script.

In the following part, specify values appropriate for your environment:

communication-protocol: //host-name-or-IP-address-of-Web-Console-server:port-number

communication-protocol

Specify http or https as the communication protocol.

host-name-or-IP-address-of-Web-Console-server

Specify the host name or IP address of the Web Console server.

port-number

Specify the port number to be used for communication with the Web Console server. The default is 22252.

The following shows an example of defining an action in the automated action definition file and an example of the batch file to run:

Example of specifying an action:

```
# Example of action definition in the automated action definition file
cmd C:\launch_ajs_webcon.bat $EVHOST$URLENC $EV"OBJECT_NAME"$URLENC $EV"A3"
"$URLENC
```

Example of batch file:

```
rem Example of the batch file called by the automated action
rem launch_ajs_webcon.bat
"C:\Program Files (x86)\HITACHI\JP1Cons\bin\jimmail.exe" -s " Job error no
tification" -b "A job error was detected. Access the following URL, and ch
eck the details.\nhttp://hostA:22252/ajs/login.html?manager=%1&type=monito
r&unitName=%2&execID=%3&eou=1"
```

9.2.5 JP1 events supported by JP1/IM linkage

The following table lists the IDs of JP1 events supported by JP1/IM linkage of JP1/AJS3 - Web Console.

Table 9–1: List of JP1 events supported by JP1/IM linkage

Event ID	Event name
00004102	Jobnet start event
00004103	Jobnet normal end event
00004104	Jobnet abnormal end event
00004105	Job start event
00004106	Job normal end event

Event ID	Event name
00004107	Job abnormal end event
00004108	Jobnet warning end event
00004109	Job warning end event
0000410A	Queued job canceled event
00004120	Held jobnet event
00004121	Held job event
00004122	Jobnet delayed start event
00004123	Jobnet delayed end event
00004124	Next scheduled queued event
00004125	Job submission start event
00004127	Job delayed end event
00004145	End of start-condition monitoring wait event
00004146	Jobnet waiting-process start event
00004147	Jobnet waiting-process end event
00004148	Jobnet waiting-process retained event
00004149	Jobnet waiting-process resumed event
0000414A	Job waiting-process start event
0000414B	Job waiting-process end event
0000414C	Job waiting-process retained event
0000414D	Job waiting-process resumed event
00004155	Wait start event for the automatic retry interval
00004156	Start event for automatic retry execution
00004157	Error event that disables automatic retry execution
00004158	Start event for submitting jobs for automatic retry

9.3 Setup for linking JP1/IM2

This section describes the procedure for setting up linkage with JP1/IM2 and the procedure for undoing the setup (unsetup).

9.3.1 Setup procedure for linking JP1/IM2

The following figure shows an example of a system configuration for linking with JP1/IM2.

Figure 9–8: Example of a system configuration for linking with JP1/IM2

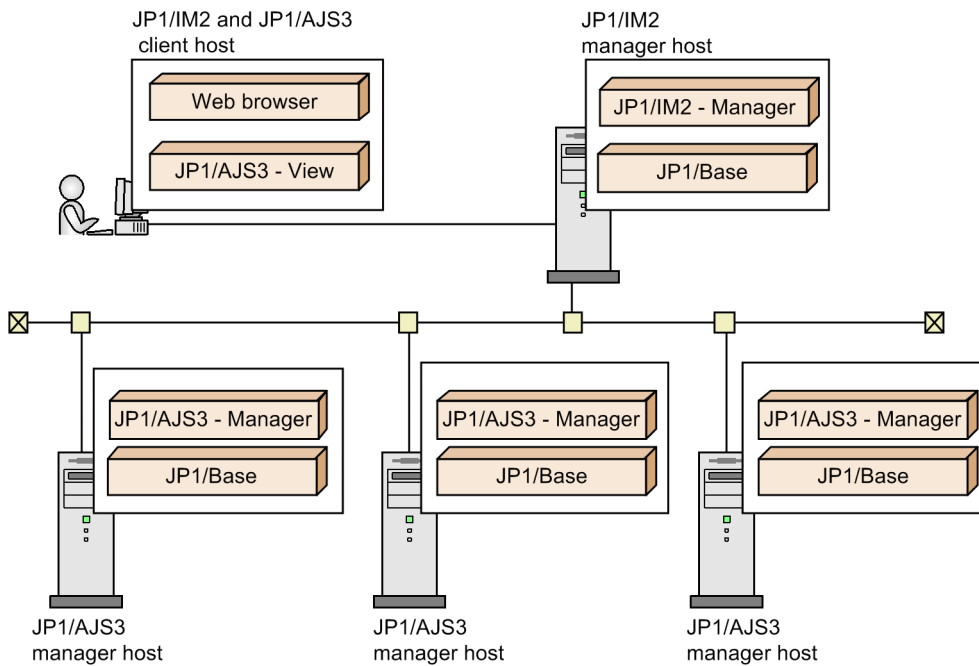

In the preceding example, JP1/IM2 is used to monitor three JP1/AJS3 hosts. In response to a request from JP1/IM2 - Manager, JP1/AJS3 - Manager on each manager host returns the configuration information of jobnets to JP1/IM2 - Manager. The events issued by all instances of JP1/AJS3 - Manager are collected by JP1/IM2 - Manager. All such communications are performed via JP1/Base.

A user who is logged in to JP1/IM2 - Manager from a web browser can view the following information: jobnet configuration information collected from the JP1/AJS3 manager hosts, jobnet statuses updated by events, and links between jobnets that use JP1 event linkage.

The following figure shows the setup procedures for linking JP1/IM2.

Figure 9–9: Setup procedures for linking JP1/IM2

(1) Procedure to be performed on the JP1/IM2 manager host

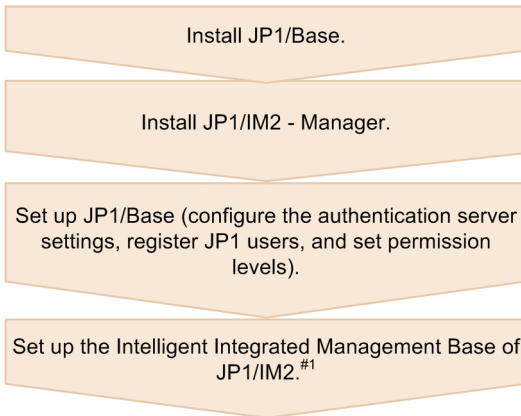

(2) Procedure to be performed on the JP1/AJS3 manager host

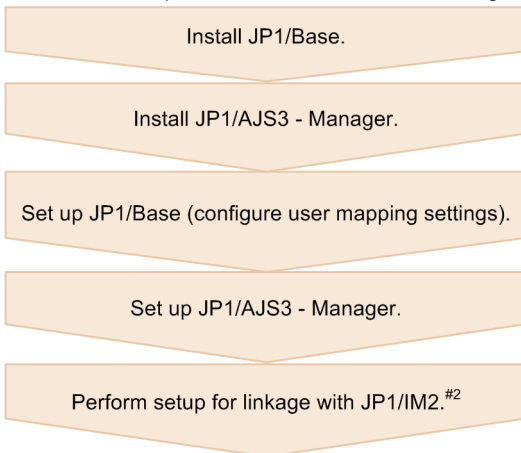

(3) Procedure to be performed on the JP1/IM2 and JP1/AJS3 client hosts

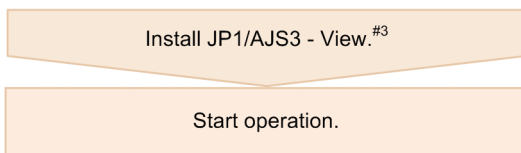

#1

For details about how to set up the JP1/AJS3 plugin settings file, see *(1) Setting up linkage with JP1/IM2 (procedure to be performed on the JP1/IM2 manager host)*.

For details about other settings, see the *JP1/Integrated Management 3 - Manager Configuration Guide*.

#2

For details, see *(2) Setting up linkage with JP1/IM2 (procedure to be performed on the JP1/AJS3 manager host)*.

#3

This procedure is unnecessary if Web GUI (Job Portal) is not used.

(1) Setting up linkage with JP1/IM2 (procedure to be performed on the JP1/IM2 manager host)

Set up the JP1/AJS3 plugin settings file on the manager host.

1. Open the JP1/AJS3 plugin settings file by using a text editor.

Open the following file:

- In Windows
`JP1/IM2-Manager-installation-folder\conf\imdd\plugin\jplajs\settings.conf`
or
`shared-folder\jplimm\conf\imdd\plugin\jplajs\settings.conf`
- In UNIX
`/etc/opt/jplimm/conf/imdd/plugin/jplajs/settings.conf`
or
`shared-directory/jplimm/conf/imdd/plugin/jplajs/settings.conf`

2. Modify the definitions to be changed.

Specify definitions in the following format.

```
{
  "ajswebconUrl": "value",
  "linkValueLimit": value,
  "prewaitLink": "{y|n}",
  "netcnLink": "{y|n}",
  "evRegexLink": "{y|n}",
  "evMacroLink": "{y|n}",
  "evotherLink": "{y|n}",
  "evIpLink": "{y|n}"
}
```

The following table shows the items to be set.

Table 9–2: Items to be set in the JP1/AJS3 plugin settings file

Item name	Value	Description of values
ajswebconUrl	<i>communication-protocol</i> : //server-name:port-number/ajs/login.html	<i>communication-protocol</i> Specify http or https as the communication protocol. <i>server-name</i> Specify the host name or IP address of the JP1/AJS3 - Web Console server. <i>port-number</i> Specify the port number to be used for communication with the JP1/AJS3 - Web Console server. If SSL communication is disabled, the default port number is 22252. If SSL communication is enabled, the default port number is 22253.
linkValueLimit	1 to 2,000	Specify a maximum number for connections among root jobnets that obtain the impact on subsequent jobs and the scheduled date and time for linkage. 64 is assumed in the following cases. <ul style="list-style-type: none"> • If the value is omitted • If a value out of range or a value that is not a number is specified as the setting
prewaitLink ^{#1}	y n	Specify whether to create associations with wait conditions. <ul style="list-style-type: none"> • y: Creates associations. • n: Does not create associations. The value to be specified (y or n) is case-sensitive. The value y is assumed in the following cases:

Item name	Value	Description of values
<code>prewaitLink</code> ^{#1}	<code>y n</code>	<ul style="list-style-type: none"> If the value is omitted If a value that is neither <code>y</code> nor <code>n</code> is specified
<code>netcnLink</code>	<code>y n</code>	<p>Specify whether to create associations with jobnet connectors.</p> <ul style="list-style-type: none"> <code>y</code>: Creates associations. <code>n</code>: Does not create associations. <p>The value to be specified (<code>y</code> or <code>n</code>) is case-sensitive.</p> <p>The value <code>y</code> is assumed in the following cases:</p> <ul style="list-style-type: none"> If the value is omitted If a value that is neither <code>y</code> nor <code>n</code> is specified
<code>evRegexLink</code>	<code>y n</code>	<p>Specify whether to apply the regular expression when creating associations with JP1 events.</p> <ul style="list-style-type: none"> <code>y</code>: Creates associations assuming that the specified values are regular expressions. <code>n</code>: Creates associations assuming that the specified values are ordinary character strings rather than regular expressions. <p>The value to be specified (<code>y</code> or <code>n</code>) is case-sensitive.</p> <p>The value <code>n</code> is assumed in the following cases:</p> <ul style="list-style-type: none"> If the value is omitted If a value that is neither <code>y</code> nor <code>n</code> is specified
<code>evMacroLink</code>	<code>y n</code>	<p>For macro variables used for JP1 event linkage, specify whether associations are created by using simple string matches, or whether associations with JP1 events that use macro variables are not created.</p> <ul style="list-style-type: none"> <code>y</code>: Creates associations by using simple string matches. <code>n</code>: Does not create associations with JP1 events that use macro variables. <p>The value to be specified (<code>y</code> or <code>n</code>) is case-sensitive.</p> <p>The value <code>y</code> is assumed in the following cases:</p> <ul style="list-style-type: none"> If the value is omitted If a value that is neither <code>y</code> nor <code>n</code> is specified
<code>evotherLink</code>	<code>y n</code>	<p>Specify whether to create associations if a unit definition^{#2} that is not used as an association condition for JP1 event linkage is used.</p> <ul style="list-style-type: none"> <code>y</code>: Creates associations. <code>n</code>: Does not create associations. <p>If you specify <code>y</code>, you can use the <code>evIpLink</code> setting to specify whether comparison is made with the IP address of the event issuer host.</p> <p>The value to be specified (<code>y</code> or <code>n</code>) is case-sensitive.</p> <p>The value <code>n</code> is assumed in the following cases:</p> <ul style="list-style-type: none"> If the value is omitted If a value that is neither <code>y</code> nor <code>n</code> is specified
<code>evIpLink</code>	<code>y n</code>	<p>Specify whether comparison is made with the IP address of the event issuer host for the JP1 event reception monitoring job.</p> <p>This item takes effect only if <code>y</code> is specified for <code>evotherLink</code>.</p> <p>If <code>n</code> is specified for <code>evotherLink</code>, the specification of this item is ignored.</p>

Item name	Value	Description of values
evIpLink	y n	<ul style="list-style-type: none"> • y: Performs comparison with the IP address. If the comparison results in a match, an association is created. In other cases, no association is created. • n: Creates an association without performing comparison with the IP address. The IP address is ignored even if it is defined. <p>The value to be specified (y or n) is case-sensitive. The value n is assumed in the following cases:</p> <ul style="list-style-type: none"> • If the value is omitted • If a value that is neither y nor n is specified

#1

When you set this item, see (2)(c) *Settings according to the operation*.

#2

The following unit definitions are not used as association conditions for JP1 event linkage:

`evusr="event-issue-source-user-name"`

Define the user name of the event issue source in the basic information on an event to be received.

`evgrp="event-issue-source-group-name"`

Define the group name of the event issue source in the basic information on an event to be received.

`evipa=event-issue-source-IP-address`

Define the IP address of the event issue source in the basic information about an event to be received.

`evuid=event-issue-source-user-ID`

Define the user ID of the event issue source in the basic information about an event to be received.

`evgid=event-issue-source-group-ID`

Define the group ID of the event issue source in the basic information about an event to be received.

`evpid=event-issue-source-process-ID`

Define the process ID of the event issue source in the basic information about an event to be received.

`evdet="detailed-event-information"`

Define a character string that is to be compared with the detailed information part of an event received.

3. Save the settings.conf file.

Important

- The settings in the JP1/AJS3 plugin settings file take effect immediately. If the file is saved at the same time that JP1/IM2 is operating, the file might not be read normally and an error might occur. In this case, save the file again.
- If a new installation of JP1/IM2 was performed, the values of the settings in the JP1/AJS3 plugin settings file are as follows:

```

{
"prewaitLink": "y",
"netcnLink": "y",
"evRegexLink": "y",
"evMacroLink": "n",
"evotherLink": "y"
"evIpLink": "y"
}

```
- If an overwrite installation or an upgrade installation of JP1/IM2 was performed, the JP1/AJS3 plugin settings file is not updated.

If no settings are specified in the JP1/AJS3 plugin settings file, assumptions are made for omitted values.

(2) Setting up linkage with JP1/IM2 (procedure to be performed on the JP1/AJS3 manager host)

To use trend information display function, make sure that the JP1/AJS3 manager host meets the following prerequisite conditions.

Prerequisite conditions:

1. On the JP1/AJS3 manager host, to change the system time by using NTP (Network Time Protocol), etc., make sure the following conditions are met.
 - Operate in slew mode, etc., and make adjustments in units of milliseconds so that the same time does not occur.
 - Configure settings to output logs when the system time is adjusted, so that time adjustments can be checked after they are made.
2. If you move the system time backward, delete the performance log files.
For details, see 7.9.3 *Changing the date and time of the system* in the *JP1/Automatic Job Management System 3 Administration Guide*.

On the JP1/AJS3 manager host, perform the following procedure to set up linkage with JP1/IM2:

(a) Setting up the adapter command settings file

1. Copy the `Adapter_HITACHI_JP1_AJS3_CONFINFO.conf.model` file to the *JP1/Base-installation-folder*\plugin\conf folder.

The following shows the location of the `Adapter_HITACHI_JP1_AJS3_CONFINFO.conf.model` file.

```
JP1/AJS3 - Manager-installation-folder\tools\IMDDAdapter\conf
```

2. Rename the copied file.

Before the change

```
Adapter_HITACHI_JP1_AJS3_CONFINFO.conf.model
```

After the change

```
Adapter_HITACHI_JP1_AJS3_CONFINFO.conf
```

If JP1/AJS3 has been installed in a folder that is not the default installation folder in Windows, additionally perform the following procedure:

1. Open the `Adapter_HITACHI_JP1_AJS3_CONFINFO.conf` file by using a text editor.
2. Change the path specified for the `cmdpath` attribute in the file.

```
fileversion      12000000
cmdpath          JP1/AJS3 - Manager-installation-folder\tools\IMDDAdapter\IM
DDAdapter_HITACHI_JP1_AJS3.bat
upperpp         /HITACHI/JP1/IM/DD
componenttype    JDD_CONFINFO
```

(b) Configuring settings to detect factors that might stop job execution

By linking with JP1/IM2, JP1/AJS3 can monitor and report the following three items to prevent failures that stop the job execution of scheduler services:

- Number of jobs in the *Now queuing* or *Now running* status
- Number of execution generations in the *Wait for start cond.* status
- Number of unreported information items managed by the event/action control manager

For details about the settings, see *21.7 Settings for detecting factors that might stop job execution* in the *JP1/Automatic Job Management System 3 Configuration Guide*.

(c) Settings according to the operation

Specify the following settings according to the operation:

- Change the value of the EXECREGISTRATIONNUMBER environment setting parameter to `execution` if either of the following conditions is met when you create a relation about waiting: 1) A time other than 0:00 is set as the base time of waiting-target units and units with wait conditions, or 2) `dword:00000030` is set for the ROOTJOBNETSCHEDULERANGE environment setting parameter of the scheduler service for which the units are defined.

9.3.2 Unsetup procedure for linking JP1/IM2

To undo the setup for linkage with JP1/IM2, delete the `Adapter_HITACHI_JP1_AJS3_CONFINFO.conf` file in the `JP1/Base-installation-folder\plugin\conf` folder (or move the file out of the folder).

9.4 Monitoring jobnets using JP1/IM

By linking JP1/IM which provides integrated management of the JP1-series programs, the following operations are available:

- Check the JP1 events issued by JP1/AJS3 in the Event Console window of JP1/IM - View.
- Call the JP1/AJS3 - View window from JP1/IM - View.
- Call the Web GUI (Job Portal) screen from JP1/IM - View.

Read the following for details.

9.4.1 Check JP1 events in the Event Console window

The Event Console window of JP1/IM - View displays information based on the JP1 events that are sent from JP1-series programs.

The Event Console window displays the severity of events (Error, Warning), names of the programs and the names of the hosts that issued events, the time and date when JP1 events are received, and messages. The window also displays the end status of jobnets (whether a jobnet ended normally or abnormally) and the execution status of jobnets (execution started, or the status during execution).

When you select the status of a JP1/AJS3 job or jobnet displayed on the Event Console window and click the **Monitor** button, the Jobnet Monitor window of JP1/AJS3 - View or the Monitor screen of Web GUI (Job Portal) appears.

9.4.2 Displaying JP1/AJS3 - View from JP1/IM - View

This subsection shows the procedure for displaying JP1/AJS3 - View from JP1/IM - View. You can call JP1/AJS3 - View from the following JP1/IM - View windows. For each window, how to call JP1/AJS3 - View is described below.

- Tool Launcher window
- Event Console window

When you call the JP1/AJS3 - View window from JP1/IM - View, you must have JP1/AJS3 - View and JP1/IM - View installed on the same host.

(1) From the Tool Launcher window

To display JP1/AJS3 - View:

1. Display the Tool Launcher window in JP1/IM - View.

The Tool Launcher window displays the programs you can call from JP1/IM - View in a tree structure.

2. In the tree, click **Job Management** folder.

The menu in the tree expands.

3. From the expanded menu, click **Job Scheduler** menu.

When you click the menu, the Login screen of JP1/AJS3 - View appears. You cannot enter the JP1 user name and password here because those you entered when logging in to JP1/IM - View are used. In addition, if JP1/AJS3 - View fails to log in to JP1/AJS3 - Manager for reasons such as the authentication bloc of JP1/AJS3 - Manager on the

specified connection-destination host is different or the authentication server restarted, an error message is displayed, and then the JP1 user name and password can be entered again.

Specify the necessary information on the Login screen, and then click the **OK** button. The JP1/AJS3 - View window appears.

(2) From the Event Console window

To display JP1/AJS3 - View:

1. Display the JP1/IM - View Event Console window.
2. From the JP1 events displayed in the Event Console window, choose the JP1 event issued by JP1/AJS3.
3. Click the Monitor Start button.

You are connected to the host that has issued the JP1 event and the Jobnet Monitor window of JP1/AJS3 - View appears.

The Jobnet Monitor window displays the jobnet relevant to the selected JP1 event.

If you have made settings as described in *9.2.1 Setup for displaying the job that has output the JP1 event in the Jobnet Monitor*, the window displays the jobnet to which the job causing the JP1 event belongs. Otherwise, the window displays the root jobnet to which the job causing the JP1 event belongs.

When you display JP1/AJS3 - View, the JP1 user name and password you used to log in to JP1/IM - View are used. Therefore, the Login screen of JP1/AJS3 - View does not appear as long as the authentication bloc is the same.

9.4.3 Displaying Web GUI (Job Portal) from JP1/IM - View

You can use one of the following three methods to open the screen of Web GUI (Job Portal) from JP1/IM:

- Use the **Monitor** button in the Event Console window of JP1/IM - View
The Jobnet Monitor window of JP1/AJS3 - View is the default screen displayed by clicking the **Monitor** button. However, you can change the default screen to the Monitor screen of Web GUI (Job Portal) by performing the procedure in *9.2.2 Setup for displaying Web GUI (Job Portal) from the Event Console window of JP1/IM - View*.
- Use a hyperlink displayed in the Event Details window of JP1/IM - View
To display a hyperlink to the Monitor screen of Web GUI (Job Portal) in the Event Details window, perform the procedure in *9.2.3 Setup for displaying a hyperlink to Web GUI (Job Portal) in the Event Details window of JP1/IM - View*.
- Use the URL displayed in an email sent by an automated action
To display the URL of the Monitor screen of Web GUI (Job Portal) in emails sent by automated actions, perform the procedure in *9.2.4 Setup for displaying a Web GUI (Job Portal) URL in emails sent by automated actions of JP1/IM*.

The following describes how to display the Web GUI (Job Portal) screens.

Cautionary notes

- You can open the Web GUI (Job Portal) screen only if units or generations that will be displayed on that page exist.
- If the function that restricts the JP1/AJS3 - Manager hosts to which connections can be established is used on the Web Console server, the following applies: Before you can use JP1/IM - View to monitor a JP1/AJS3 - Manager host to which the Web Console server is to be connected, you must permit connection to the JP1/AJS3 - Manager host. To permit connection to a JP1/AJS3 - Manager host, specify the name of the host in the environment settings file (`ajs3web.conf`) of the Web Console server. For details about the environment settings file (`ajs3web.conf`) in Windows, see *3.4.3 Details on the settings in the environment-settings file (ajs3web.conf)*

in the *JP1/Automatic Job Management System 3 Configuration Guide*. For details about the environment settings file (`ajs3web.conf`) in Linux, see *13.3.3 Details on settings in the environment-settings file (ajs3web.conf)* in the *JP1/Automatic Job Management System 3 Configuration Guide*.

(1) Using the Monitor button in the Event Console window of JP1/IM - View

1. Display the JP1/IM - View Event Console window.
2. From the JP1 events displayed in the Event Console window, choose the JP1 event issued by JP1/AJS3.

Cautionary note

Web GUI (Job Portal) pages can be displayed only for JP1 events that are issued by JP1/AJS3 - Manager 11-00 or later.

3. Click the Monitor Start button.
The Monitor screen appears. You are automatically logged in to JP1/AJS3 with your JP1/IM login account.
The Monitor screen displays the unit related to the JP1 event you chose.

(2) Using a hyperlink displayed in the Event Details window of JP1/IM - View

1. Display the JP1/IM - View Event Console window.
2. From the JP1 events displayed in the Event Console window, choose the JP1 event issued by JP1/AJS3.

Cautionary note

Web GUI (Job Portal) pages can be displayed only for JP1 events that are issued by JP1/AJS3 - Manager 11-00 or later.

3. Click the Event Details button.
The Event Details window for the JP1 event that you chose appears.
4. In the **Guide** area, click a hyperlink to the Monitor screen of Web GUI (Job Portal).
If the hyperlink uses a URL that supports single sign-on, the Monitor screen opens immediately. You are automatically logged in to JP1/AJS3 with your JP1/IM login account.
If the hyperlink uses a URL that does not support single sign-on, the Web GUI (Job Portal) login screen first opens. In this screen, enter your JP1 user name and password, and then click the **OK** button.
The Monitor screen opens, displaying the unit related to the JP1 event you chose.

(3) Using the URL displayed in an email sent by an automated action

1. Display the email sent by an automated action.
2. In the email body, click the URL of the Monitor screen of Web GUI (Job Portal).
The Login screen of Web GUI (Job Portal) appears.
3. Enter information in the **User name** and **Password**, and then click **OK**.
In the User name and Password fields, specify the user name and password of the JP1 user who is to log in.
If login is successful, the Monitor screen of Web GUI (Job Portal) appears. The Monitor screen displays the unit related to the JP1 event for which the email was sent.

9.5 About suggestion templates in JP1/IM2

JP1/AJS3 provides suggestion templates as templates for the JP1/IM2 function that suggests response actions appropriate to the system status. This section describes these suggestion templates. For details about the JP1/IM2 function that suggests response actions appropriate to the system status, see the *JP1/Integrated Management 3 - Manager Overview and System Design Guide*.

There are the following two suggestion templates that use JP1/AJS3:

- Template for checking root jobnets that are affected when an agent host stops
- Template for checking execution agents that are affected when an agent host stops

The following figures show system configurations in which the preceding suggestion templates can be used. These suggestion templates assume that JP1/PFM is used to monitor whether a host has stopped.

Figure 9–10: System configuration that uses a JP1/PFM agent monitoring product

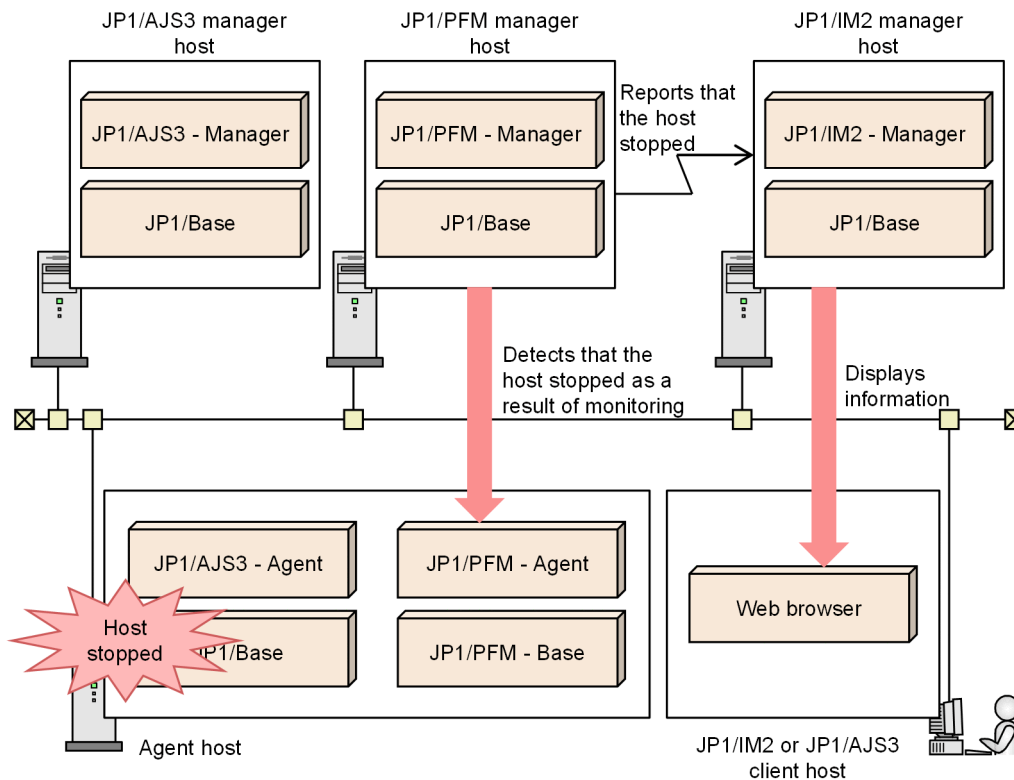
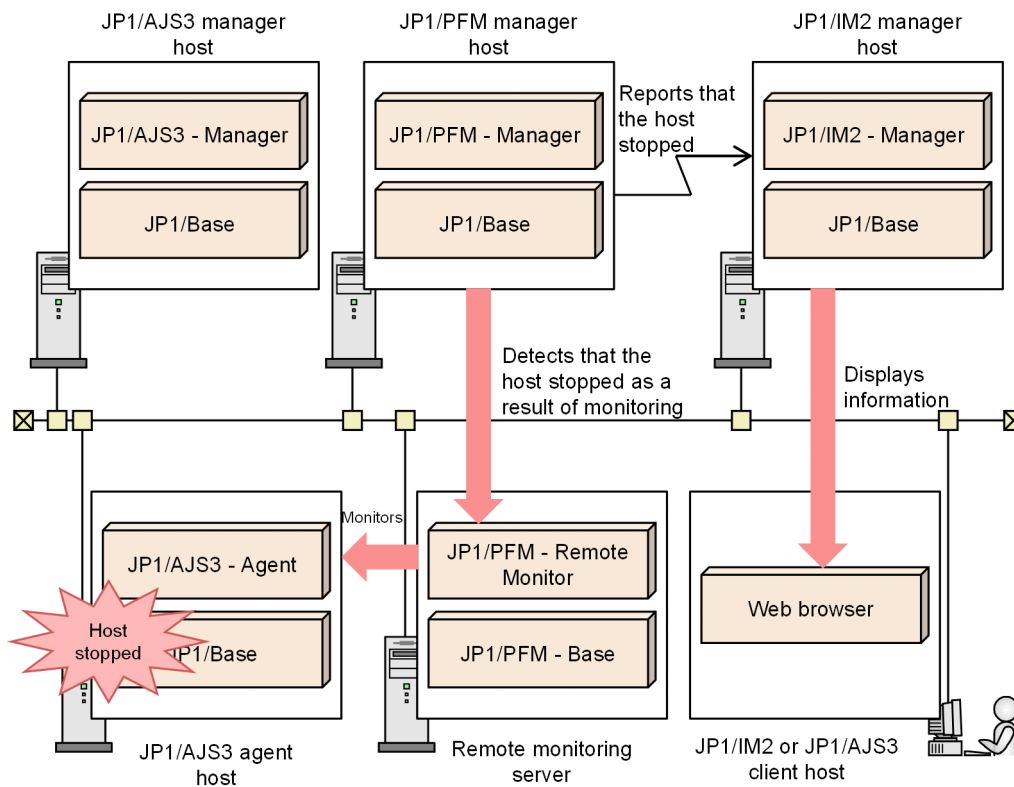

Figure 9–11: System configuration that uses a JP1/PFM remote monitoring product



9.5.1 Checking the root jobnets that are affected when an agent host stops

This section describes the template for checking root jobnets that are affected when an agent host stops.

If you execute the response action of this suggestion template, the window is changed automatically to a JP1/IM2 window that displays the root jobnets affected when the agent host on which JP1/AJS3 - Agent is installed stops. If an agent host stops, you can quickly identify the scope of job executions that will be affected in JP1/IM2 and can take countermeasures for the jobs that are scheduled to be run. This can prevent the affected scope from expanding.

Cautionary notes

- If the JP1 user who is logged in to JP1/IM2 does not have permissions to view root jobnets, they cannot check detailed information about the affected root jobnets in the **Related Nodes** tab of JP1/AJS3 - Agent. If you use this suggestion template, set up the JP1 resource group so that the JP1 user who takes countermeasures in JP1/IM2 can view root jobnets.
- Use this suggestion template on the assumption that the user handles the impact by stoppage of the agent host on which JP1/AJS3 - Agent is installed. You cannot use this suggestion template in a case where the manager host on which JP1/AJS3 - Manager is installed has stopped.

(1) Prerequisite conditions

Before using the template for checking root jobnets that are affected when an agent host stops, make sure that the following prerequisite conditions are met:

1. The version of JP1/AJS3 - Manager is 12-10 or later.
2. The host on which JP1/AJS3 - Agent is installed is monitored by using the health check function of JP1/PFM.

3. The versions of JP1/IM2 and JP1/PFM - Manager are 12-50 or later.
4. JP1/IM2 is able to obtain system configuration information from JP1/AJS3 and JP1/PFM.

For details about the settings that are necessary for linkage between JP1/IM2 and JP1/AJS3, see [9.3 Setup for linking JP1/IM2](#).

For details about the settings that allow linkage between JP1/IM2 and JP1/PFM, see the *JP1/Performance Management User's Guide*. For details about the health check function of JP1/PFM, see the *JP1/Performance Management Planning and Configuration Guide*.

(2) Suggestion template

The following shows the file name of the suggestion template. The following also provides an overview and specification example of the suggestion template.

File name

For the Japanese version of JP1/IM2:

```
imdd_suggestion_ajs_check_failed_agent_jobnet_ja.conf
```

For the English version of JP1/IM2:

```
imdd_suggestion_ajs_check_failed_agent_jobnet_en.conf
```

For details about the location where suggestion templates are stored, see the *JP1/Integrated Management 3 - Manager Administration Guide*.

Overview

The following table provides an overview of this suggestion template.

No.	Item	Overview
1	Node on which suggestion information is shown	Node showing the JP1/PFM monitoring agents of the Management Applications category
2	JP1 user permission under which the suggestion information is shown	JP1_AJS_User or higher and JP1_PFM_Operator or higher
3	Suggestion activation criteria	<ul style="list-style-type: none"> • The host that stopped is used as an execution agent of jobs • JP1/PFM issues a JP1 event indicating the Host Not Available status of the target host, and the status of that JP1 event in JP1/IM2 is Unprocessed • Information acquisition of the host on which JP1/PFM has stopped is successful • At the time of condition judgment, the target host has not recovered from the Host Not Available status
4	Response action	Go to the JP1/AJS3 - Agent node, and display the relationship between the stopped host and the root jobnet on the Related node tab

The suggestion activation criteria "JP1/PFM issues a JP1 event indicating the Host Not Available status of the target host, and the status of that JP1 event in JP1/IM2 is Unprocessed" of this suggestion template evaluates whether JP1 events issued by JP1/PFM are registered in JP1/IM2 as Severe events that satisfy the following conditions.

No.	JP1 event attributes	Value
1	Event ID	4860
2	Message	The character string (hcsstatus=Host Not Available) is included.

No.	JP1 event attributes	Value
3	Event level	Error
4	Response status	Unprocessed

Cautionary notes

- If JP1/IM2 is used to change the Event levels or Severe event definitions of JP1 events
If the following JP1/IM2 functions are used, the response action is not suggested by this suggestion template when the agent host is stopped.
 - Function for changing severity levels
 - Function for defining severe events
 - Function for releasing severe events
 - Function for deleting severe events
Customize the suggestion activation criteria "JP1/PFM issues a JP1 event indicating the Host Not Available status of the target host, and the status of that JP1 event in JP1/IM2 is Unprocessed" to match the Event levels or Severe event definitions of the monitored JP1 events.
- If the Event levels of JP1 events issued by JP1/PFM are changed
If the Event level of the JP1 events issued when the health check status is "Host Not Available" is changed from the default (Error), the response action is not suggested by this suggestion template when the agent host is stopped. Customize the suggestion activation criteria "JP1/PFM issues a JP1 event indicating the Host Not Available status of the target host, and the status of that JP1 event in JP1/IM2 is Unprocessed" to match the Event levels of the monitored JP1 events.

An example of coding

```
{
  "meta":{
    "version":"1"
  },
  "suggestions":[
    {
      "suggestionId":"jpl_ajs_check_failed_agent_jobnet",
      "label":"Check the root jobnet affected by the stopped host",
      "node": "_CATEGORY_m.*_OBJECT_JP1PFM-A([^\1478]|[\1478].*%5B([^\%]*%5D|(|\.\.\.|[^\A]\.\.\.|[^\1]\.\.\.|[^\1]|.{4,})%40))",
      "permissions":[
        ["JP1_PFM_Admin","JP1_AJS_Guest"],
        ["JP1_PFM_Admin","JP1_AJS_Operator"],
        ["JP1_PFM_Admin","JP1_AJS_Editor"],
        ["JP1_PFM_Admin","JP1_AJS_Manager"],
        ["JP1_PFM_Admin","JP1_AJS_Admin"],
        ["JP1_PFM_Operator","JP1_AJS_Guest"],
        ["JP1_PFM_Operator","JP1_AJS_Operator"],
        ["JP1_PFM_Operator","JP1_AJS_Editor"],
        ["JP1_PFM_Operator","JP1_AJS_Manager"],
        ["JP1_PFM_Operator","JP1_AJS_Admin"]
      ],
      "cases":[
        [
          {
            "type":"struct",
            "key":{
              "idType":"target",
              "sid":"${../../_OBJECT_JP1AJSAGT/<managerAgent:target:sid:}"
            }
          ]
        ]
      ]
    }
  ]
}
```



```

relationship between the stopped host and the root jobnet on the Related node
  e tab"
    }
  }
]
}

```

For details about each item in the suggestion template, see the description of the suggestion definition file in the manual *JP1/Integrated Management 3 - Manager Command, Definition File and API Reference*.

(3) Procedure for applying the template

The following shows the procedure for applying the suggestion template to JP1/IM2:

1. Copy the suggestion template to any folder of your choice on the JP1/IM2 manager host.
2. On the JP1/IM2 manager host, run the `jddupdatesuggestion` command in which the path of the folder to which the suggestion template was copied is specified as an argument.

(4) Procedure for customizing the template

In this suggestion template, you can change JP1/PFM to another product that monitors stoppage of an agent host. In this case, however, the mechanism of agent host stoppage detection follows the specifications of the new monitoring product. If you change JP1/PFM to another monitoring product, change the settings of the following items in the suggestion template according to the new monitoring product:

- Node on which suggestion information is shown
- JP1 user permission under which the suggestion information is shown
- The following three suggestion activation criteria:
 - JP1/PFM issues a JP1 event indicating the Host Not Available status of the target host, and the status of that JP1 event in JP1/IM2 is Unprocessed
 - Information acquisition of the host on which JP1/PFM has stopped is successful
 - At the time of condition judgment, the target host has not recovered from the Host Not Available status

In addition, change the following variables so that the path is a relative path starting from the IM management node on which the suggestion is shown.

No.	Item	Description	Variable
1	Node of the Destination JP1/AJS3 - Manager	Indicates the JP1/AJS3 - Manager node that is connected with a relation to managerAgent and the JP1/AJS3 - Agent node of the host that stopped. Specify a relative path starting from the IM management node on which the suggestion is shown.	<code>`\${../../_OBJECT_JP1AJSAGT/<managerAgent:target:side>}</code>

No.	Item	Description	Variable
2	Object root of the host that stopped	Indicates the node indicating the Object root of the host that stopped. Specify a relative path starting from the IM management node on which the suggestion is shown.	<code>`\${../..../..:tree:sid:URLENC}`</code>

The following shows the procedure for customizing the suggestion template:

1. Copy the suggestion template to any folder of your choice on the JP1/IM2 manager host.
2. Rename the suggestion template you have copied.
Rename the copied suggestion template to `imdd_suggestion_X.conf` (*X*: a name of your choice).
3. Use a text editor to open the suggestion template that you have copied, and then edit the settings in the template.
4. On the JP1/IM2 manager host, run the `jddupdatesuggestion` command in which the path of the folder to which the suggestion template was copied is specified as an argument.

Cautionary note

Save the suggestion template in UTF-8 encoding without BOM.

9.5.2 Checking the execution agents that are affected when an agent host stops

This section describes the template for checking execution agents that are affected when an agent host stops.

If you execute the response action of this suggestion template, the window is automatically changed to a JP1/IM2 window that displays a list of execution agents affected when the agent host on which JP1/AJS3 - Agent is installed stops.

(1) Prerequisite conditions

Before using the template for checking execution agents that are affected when an agent host stops, make sure that the following prerequisite conditions are met:

1. The versions of JP1/AJS3 - Manager and JP1/AJS3 - Web Console are 12-50 or later.
2. The host on which JP1/AJS3 - Agent is installed is monitored by using the health check function of JP1/PFM.
3. The versions of JP1/IM2 and JP1/PFM - Manager are 12-50 or later.
4. JP1/IM2 is able to obtain system configuration information from JP1/AJS3 and JP1/PFM.

For details about the settings that are necessary for linkage between JP1/IM2 and JP1/AJS3, see [9.3 Setup for linking JP1/IM2](#).

For details about the settings that allow linkage between JP1/IM2 and JP1/PFM, see the *JP1/Performance Management User's Guide*. For details about the health check function of JP1/PFM, see the *JP1/Performance Management Planning and Configuration Guide*.

(2) Suggestion template

The following shows the file name of the suggestion template. The following also provides an overview and specification example of the suggestion template.

File name

For the Japanese version of JP1/IM2:

```
imdd_suggestion_ajs_check_failed_agent_list_ja.conf
```

For the English version of JP1/IM2:

```
imdd_suggestion_ajs_check_failed_agent_list_en.conf
```

For details about the location where suggestion templates are stored, see the *JP1/Integrated Management 3 - Manager Administration Guide*.

Overview

The following table provides an overview of this suggestion template.

No.	Item	Overview
1	Node on which suggestion information is shown	Node showing the JP1/PFM monitoring agents of the Management Applications category
2	JP1 user permission under which the suggestion information is shown	JP1_JPQ_User or higher and JP1_PFM_Operator or higher
3	Suggestion activation criteria	<ul style="list-style-type: none">• The host that stopped is used as an execution agent of jobs• JP1/PFM issues a JP1 event indicating the Host Not Available status of the target host, and the status of that JP1 event in JP1/IM2 is Unprocessed• Information acquisition of the host on which JP1/PFM has stopped is successful• At the time of condition judgment, the target host has not recovered from the Host Not Available status
4	Response action	Go to JP1/AJS3 - Web Console, and display the execution agent that uses the stopped host as an execution-target host in the Execution Agent tab

The suggestion activation criteria "JP1/PFM issues a JP1 event indicating the Host Not Available status of the target host, and the status of that JP1 event in JP1/IM2 is Unprocessed" of this suggestion template evaluates whether JP1 events issued by JP1/PFM are registered in JP1/IM2 as Severe events that satisfy the following conditions.

No.	JP1 event attributes	Value
1	Event ID	4860
2	Message	The character string (hcsstatus=Host Not Available) is included.
3	Event level	Error
4	Response status	Unprocessed

Cautionary notes

- If JP1/IM2 is used to change the Event levels or Severe event definitions of JP1 events
If the following JP1/IM2 functions are used, the response action is not suggested by this suggestion template when the agent host is stopped.
 - Function for changing severity levels
 - Function for defining severe events

- Function for releasing severe events
- Function for deleting severe events

Customize the suggestion activation criteria "JP1/PFM issues a JP1 event indicating the Host Not Available status of the target host, and the status of that JP1 event in JP1/IM2 is Unprocessed" to match the Event levels or Severe event definitions of the monitored JP1 events.

- If the Event levels of JP1 events issued by JP1/PFM are changed

If the Event level of the JP1 events issued when the health check status is "Host Not Available" is changed from the default (Error), the response action is not suggested by this suggestion template when the agent host is stopped. Customize the suggestion activation criteria "JP1/PFM issues a JP1 event indicating the Host Not Available status of the target host, and the status of that JP1 event in JP1/IM2 is Unprocessed" to match the Event levels of the monitored JP1 events.

An example of coding

```
{
  "meta":{
    "version":"1"
  },
  "suggestions":[
    {
      "suggestionId":"jpl_ajs_check_failed_agent_list",
      "label":"Check the execution agent affected by the stopped host",
      "node":"_CATEGORY_m.*_OBJECT_JP1PFM-A([1478]|1478).*%5B([%]*%5D|(.|..|[^A]..|[1]).|[1]).|[1]|.{4,})%40)",
      "permissions":[
        ["JP1_PFM_Admin","JP1_JPQ_User"],
        ["JP1_PFM_Admin","JP1_JPQ_Operator"],
        ["JP1_PFM_Admin","JP1_JPQ_Admin"],
        ["JP1_PFM_Operator","JP1_JPQ_User"],
        ["JP1_PFM_Operator","JP1_JPQ_Operator"],
        ["JP1_PFM_Operator","JP1_JPQ_Admin"]
      ],
      "cases":[
        [
          {
            "type":"struct",
            "key":{
              "idType":"target",
              "sid":"${../../_OBJECT_JP1AJSAGT/<managerAgent:target:sid:}"
            },
            "ope":"EXIST",
            "val":true,
            "description":"The host that stopped is used as an execution agent of jobs"
          },
          {
            "type":"event",
            "key":{
              "statusFilter":[30],
              "sid":"${.:tree:sid:}",
              "B.ID":["00004860"],
              "REGEX_B.MESSAGE":"KAVL15022-E.*hcsstatus=Host Not Available",
              "E.@JP1IM_DEALT":[0]
            },
            "ope":"EXIST",
            "val":true,
          }
        ]
      ]
    }
  ]
}
```

```

        "description": "JP1/PFM issues a JP1 event indicating the Host
Not Available status of the target host, and the status of that JP1 event
in JP1/IM2 is Unprocessed"
    },
    {
        "type": "plugin",
        "key": {
            "sid": "${.:tree:sid}",
            "method": "jplpfmSuggestionGetAgentAllInformation",
            "args": {}
        },
        "ope": "NOTIN",
        "val": "",
        "description": "Information acquisition of the host on which JP
1/PFM has stopped is successful"
    },
    {
        "type": "plugin",
        "key": {
            "sid": "${.:tree:sid}",
            "method": "jplpfmSuggestionGetAgentInformation",
            "args": {
                "allInformation": "${:plugin[1]::}",
                "member": "healthDetail"
            }
        },
        "ope": "IN",
        "val": "Host Not Available",
        "description": "At the time of condition judgment, the target h
ost has not recovered from the Host Not Available status"
    }
]
],
"action": {
    "type": "jump",
    "params": {
        "url": "http://(server-name):(port-number)/ajs/login.html?jt=${:u
ser:jplToken:URLENC}&manager=${../../_OBJECT_JP1AJSAGT/<managerAgent/..../.
:tree:value.label:URLENC}&type=agent&agentHost=${../..../:tree:value.labe
l:URLENC}&eou=1",
        "target": "_blank"
    },
    "description": "Go to JP1/AJS3 - Web Console, and display the execu
tion agent that uses the stopped host as an execution-target host in the e
xecution agent tab"
    }
}
]
}

```

For details about each item in the suggestion template, see the description of the suggestion definition file in the manual *JP1/Integrated Management 3 - Manager Command, Definition File and API Reference*.

(3) Procedure for applying the template

The following shows the procedure for applying the suggestion template to JP1/IM2:

1. Copy the suggestion template to any folder of your choice on the JP1/IM2 manager host.
2. Use a text editor to open the suggestion template that you have copied, and then edit the settings in the template. In the `url` key, change the server name and port number of the JP1/AJS3 - Web Console host according to the environment:

```
"url": "http://host-name-or-IP-address-of-Web-Console-server:port-number/ajs/login.html",
```

3. On the JP1/IM2 manager host, run the `jddupdatesuggestion` command in which the path of the folder to which the suggestion template was copied is specified as an argument.

(4) Procedure for customizing the template

In this suggestion template, you can change JP1/PFM to another product that monitors stoppage of an agent host. In this case, however, the mechanism of agent host stoppage detection follows the specifications of the new monitoring product. If you change JP1/PFM to another monitoring product, change the settings of the following items in the suggestion template according to the new monitoring product:

- Node on which suggestion information is shown
- JP1 user permission under which the suggestion information is shown
- The following three suggestion activation criteria:
 - JP1/PFM issues a JP1 event indicating the Host Not Available status of the target host, and the status of that JP1 event in JP1/IM2 is Unprocessed
 - Information acquisition of the host on which JP1/PFM has stopped is successful
 - At the time of condition judgment, the target host has not recovered from the Host Not Available status

In addition, change the following variables so that the path is a relative path starting from the IM management node on which the suggestion is shown.

No.	Item	Description	Variable
1	Node of the Destination JP1/AJS3 - Manager	Indicates the JP1/AJS3 - Manager node that is connected with a relation to <code>managerAgent</code> and the JP1/AJS3 - Agent node of the host that stopped. Specify a relative path starting from the IM management node on which the suggestion is shown.	<code>\${../../_OBJECT_JP1AJSAGT/<managerAgent:target:sid>}</code>
2	Host name of the Destination JP1/	Indicates the label name of JP1/AJS3 - Manager that is	<code>\${../../_OBJECT_JP1AJSAGT/<managerAgent/../../tree:value.label:URLENC}</code>

No.	Item	Description	Variable
2	AJS3 - Manager	connected with a relation to managerAgent and the JP1/AJS - Agent node of the host that stopped. Specify a relative path starting from the IM management node on which the suggestion is shown.	<code>\${../../_OBJECT_JP1AJSAGT/<managerAgent/../../tree:value.label:URLENC}</code>
3	Host name of the host that stopped	Indicates the label name of the node of the host that stopped. Specify a relative path starting from the IM management node on which the suggestion is shown.	<code>\${../../tree:value.label:URLENC}</code>

The following shows the procedure for customizing the suggestion template:

1. Copy the suggestion template to any folder of your choice on the JP1/IM2 manager host.
2. Rename the suggestion template you have copied.
Rename the copied suggestion template to `imdd_suggestion_X.conf` (*X*: a name of your choice).
3. Use a text editor to open the suggestion template that you have copied.
4. Edit the server name and port number of the JP1/AJS3 - Web Console host.
In the `url` key, change the server name and port number of the JP1/AJS3 - Web Console host according to the environment.

```
"url": "http://host-name-or-IP-address-of-Web-Console-server:port-number/ajs/login.html",
```

5. Edit the settings that you want to customize.
6. On the JP1/IM2 manager host, run the `jddupdatesuggestion` command in which the path of the folder to which the suggestion template was copied is specified as an argument.

Cautionary note

Save the suggestion template in UTF-8 encoding without BOM.

10

Automatic Distribution Using JP1/ Software Distribution

This chapter explains how to distribute unit definition information, including calendar information, about the units defined by JP1/AJS3, and explains how to distribute to remote host using JP1/Software Distribution.

10.1 Overview of linking JP1/Software Distribution

By linking JP1/Software Distribution, you can package multiple jobnets and calendars and distribute them to JP1/AJS3 - Manager on other hosts.

JP1/Software Distribution allows you to distribute and register new jobnets and calendars in a batch when you change the definition of jobnets and calendars. This eases the management of tasks in a large system.

10.2 Setup for linking JP1/Software Distribution

This section describes the setup for linking JP1/Software Distribution to distribute jobnets automatically.

The following figure shows an example of a system configuration for linking with JP1/Software Distribution.

Figure 10–1: Example of a system configuration for linking with JP1/Software Distribution

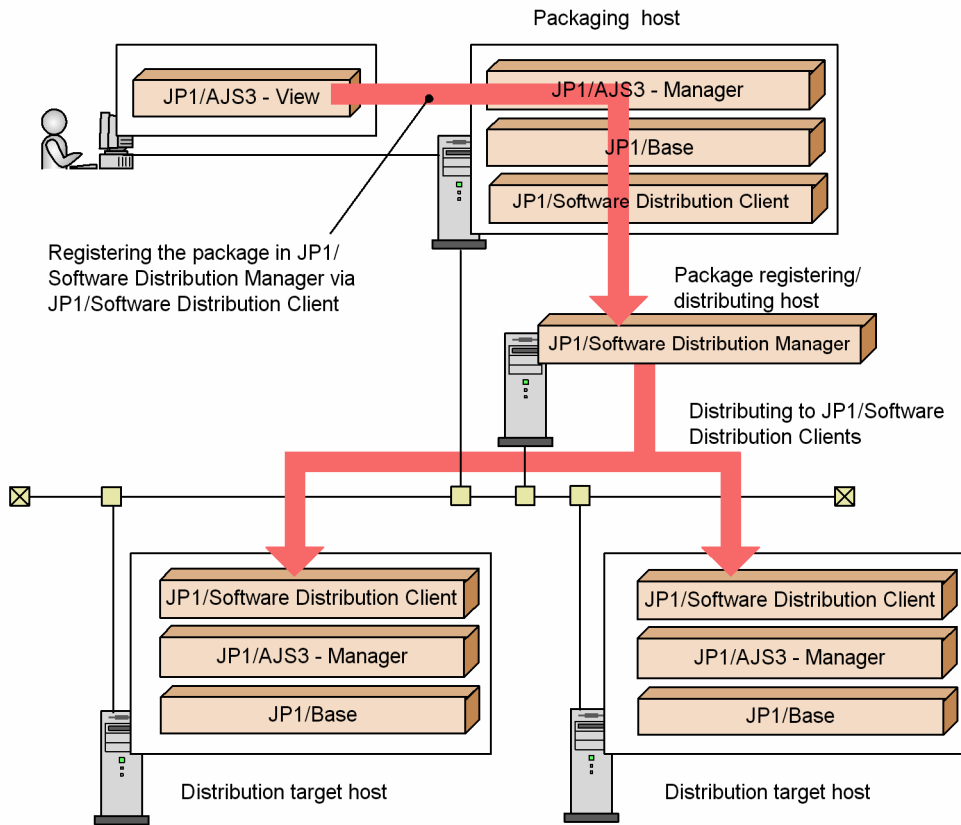

The host to which JP1/AJS3 - View is connecting (the host where JP1/Software Distribution Client is installed) is called the *packaging execution host*. The host to which JP1/Software Distribution Client on the packaging execution host is connecting (the host where JP1/Software Distribution Manager is installed) is called the *package registration host*. The package registration host is also called the *package source host* because it distributes the package to JP1/Software Distribution Client. The host to which JP1/Software Distribution Manager on the package source host distributes the package is called the *package destination host*.

The packaging execution host must have JP1/Software Distribution Client installed on it.

In this example, JP1/AJS3 - Manager and JP1/Software Distribution Manager are installed on separate hosts. You can, however, also install them on the same host.

The packaging execution host and package destination host must have the same type of OS (Windows or UNIX) installed. In UNIX, make sure that the execution and destination hosts also have the same system language. Packages registered from a Windows packaging execution host can be distributed only to Windows hosts. Packages registered from a UNIX packaging execution host can be distributed only to UNIX hosts that use the same system language.

The following figure shows the setup procedures for linking JP1/Software Distribution.

Figure 10–2: Setup procedures for linking JP1/Software Distribution

(1) Procedure for the packaging host



(2) Procedure for the package registering/package distributing host

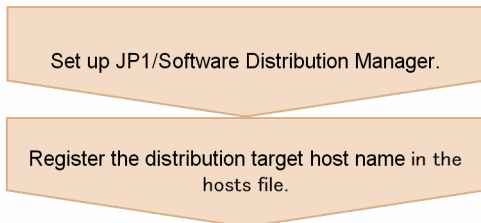

(3) Procedure for the distribution target host

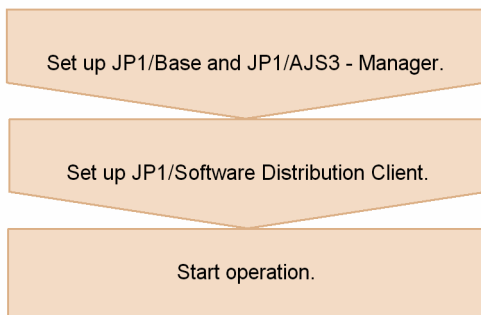

Cautionary note

For a Windows host, it is necessary to add the value *JP1/Software-Distribution-Client-installation-folder\bin* to the PATH environment variable.

For further details on setting up JP1/Software Distribution in Windows, see the *Job Management Partner 1/Software Distribution Setup Guide* (for Windows systems). In UNIX, see the *Job Management Partner 1/Software Distribution Manager Description and Administrator's Guide*, *Job Management Partner 1/Software Distribution SubManager Description and Administrator's Guide* (for UNIX systems), and *Job Management Partner 1/Software Distribution Client* (for UNIX systems).

10.3 Automatic distribution procedure

This section describes the tasks required for packaging unit definition information and including calendar information about units defined by JP1/AJS3, and how to automatically distribute a package to remote hosts using JP1/Software Distribution.

To automatically distribute tasks:

1. Package the unit definition information and calendar information in the Package dialog box of JP1/AJS3 - View. At packaging, specify a package name, where to recover the package in the host, and other information.
2. Distribute packaged information (a *package*) to the remote host using JP1/Software Distribution Manager.

For further details, see *12.3.6 Package dialog box* in the *JP1/Automatic Job Management System 3 Operator's Guide*.

For further details on JP1/Software Distribution for Windows, see the *Job Management Partner 1/Software Distribution Setup Guide* (for Windows Systems), *Job Management Partner 1/Software Distribution Administrator's Guide Volume 1* (for Windows Systems), and *Job Management Partner 1/Software Distribution Administrator's Guide Volume 2* (for Windows Systems). For further details on JP1/Software Distribution for UNIX, see the *Job Management Partner 1/Software Distribution Manager Description and Administrator's Guide*, *Job Management Partner 1/Software Distribution SubManager Description and Administrator's Guide* (for UNIX systems) and *Job Management Partner 1/Software Distribution Client Description and User's Guide* (for UNIX systems).

10.4 Packaging

This section describes how to package the unit definition information and calendar information.

To package both the unit definition and calendar information:

1. Activate JP1/AJS3 - View.
2. In the JP1/AJS3 -View window, click the units that you want to package as well as the job group that is defined for the calendar that you want to package.
The units you click are shown in the selected status.
3. Choose **File** and **Package**.
The Package dialog box appears.
4. Define the attribute of the package.
5. Click **Package**.

According to the definition in step 4, the unit definition information and calendar information are packaged on the package registration host.

The following describes the cabinet in which the package is created and the cabinet ID.

When the package registration host or packaging execution host is a UNIX host

JP1/AJS3 - View ignores the cabinet name specified in step 4 and creates a package in the cabinet for a specified cabinet ID (group ID). The cabinet name will be the same as the cabinet ID.

When both the package registration host and packaging execution host are Windows hosts

JP1/AJS3 - View creates a package in the cabinet having the cabinet name and cabinet ID specified in step 4. However, if the specified cabinet ID has already been used, JP1/AJS3 - View ignores the cabinet name and creates a package in the cabinet for a specified cabinet ID.

The result of packaging appears in **Execution result**. For details about the error messages displayed in **Execution result**, see the *Job Management Partner 1/Software Distribution Administrator's Guide Volume 1* (for Windows Systems) and *Job Management Partner 1/Software Distribution Administrator's Guide Volume 2* (for Windows Systems) for Windows, and the *Job Management Partner 1/Software Distribution SubManager Description and Administrator's Guide* (for UNIX systems) and *Job Management Partner 1/Software Distribution Client Description and User's Guide* (for UNIX systems) for UNIX.

Cautionary note

In the Windows version of JP1/AJS3 - Manager, before you perform packaging from JP1/AJS3 - View, you must add the path *installation-folder-of-JP1/Software-Distribution-Client\Bin* in the Path environment variable of the JP1/AJS3 - Manager host.

You can only distribute packages created in Windows to Windows. You cannot distribute them to UNIX.

And, you can only distribute packages created in UNIX to UNIX. You cannot distribute them to Windows.

10.5 Automatic distribution of packages

This section describes how to automatically distribute the information packaged in the Package dialog box of JP1/AJS3 - View (package) using JP1/Software Distribution for Windows and for UNIX.

10.5.1 Automatic distribution using JP1/Software Distribution (for Windows)

Assume that **Client Manager** of JP1/Software Distribution Client and JP1/AJS3 - Manager are active at the target host.

To automatically distribute the package using JP1/Software Distribution:

1. Make sure that the name of the target host has been defined in the `hosts` file of the distributing host.
2. From the Start menu, choose **Software Distribution Manager** and **Remote Installation Manager**.
The Remote install manager window appears.
3. Choose **File - New**.
The New dialog box appears.
4. Select the System Configuration window, the Package window, and the Job Status window and then click the **OK** button.
The New dialog box closes.
The selected windows appear.
5. In the System Configuration window, click **Network** and choose **File** and **Create Host**.
The Create Host dialog box appears.
6. Specify the target host name (a host name where JP1/Software Distribution Client is installed) and then click the **OK** button.
The Create Host dialog box closes.
The specified host appears in the System Configuration window.
7. In the Package window, click the distributing package and from **Execute** choose **Execute job**.
The Define New Job dialog box appears.
8. Select **Install package** and click the **OK** button.
The Create Job dialog box appears.
9. On the **Destination** page, click the **Add** button.
The Add Destination dialog box appears.
10. Add the destination and click the **OK** button.
The destination has been added and the Add Destination dialog box closes.
If you want to redistribute a package to the host specified in the **Destination** page, click the package in the **Package** page, and then click the **Change** button to display the Change Installation Conditions dialog box. In this dialog box, on the **System Conditions** page, select **Replace existing package**.
11. Click the **Execute** button.
Distribution of the package starts.

You can check the status of package distribution from the Job Status window.

10.5.2 Automatic distribution using JP1/Software Distribution (in UNIX)

Assume that **Client Manager** of JP1/Software Distribution Client and JP1/AJS3 - Manager are active at the package-distributed destination host.

To automatically distribute the package using JP1/Software Distribution:

1. Make sure that the name of the target host has been defined in the `hosts` file of the distributing host.
2. Execute the following command to display the package information:

```
directory-storing-JP1/Software-Distribution-commands/rdsdmrsc -c
```

The package information output in the following format after the command is executed is called a *resource*.

When the packaging is performed on a Windows host:

```
D.cabinet-ID.package-ID.version-number.generation-number
```

When the packaging is performed on a UNIX host:

```
C.cabinet-ID.package-ID.version-number.generation-number
```

3. Execute the following command to generate an instruction:

```
directory-storing-JP1/Software-Distribution-commands/rdsdmind -d -a distributed-host-name -s distributing-resource-name
```

4. Execute the following command to execute the instruction:

```
directory-storing-JP1/Software-Distribution-commands/rdsdmind -x
```

5. Execute the following command to check the execution status of the instruction:

```
directory-storing-JP1/Software-Distribution-commands/rdsdmind -c
```

Supplementary notes

The following lists the commands of JP1/Software Distribution.

The JP1/Software Distribution commands are:

Command to activate JP1/Software Distribution Manager

```
directory-storing-JP1/Software-Distribution-commands/rdsdmse
```

Command to terminate JP1/Software Distribution Manager

```
directory-storing-JP1/Software-Distribution-commands/rdsdmse -p
```

Command to display resource information

```
directory-storing-JP1/Software-Distribution-commands/rdsdmrsc -c
```

Command to generate an install instruction

```
directory-storing-JP1/Software-Distribution-commands/rdsdmind -d -a distributed-host-name -s distributing-resource-name
```

Command to execute an instruction

```
directory-storing-JP1/Software-Distribution-commands/rdsdmind -x
```

Command to check the status of distribution

```
directory-storing-JP1/Software-Distribution-commands/rdsdmind -c
```

Command to delete a resource

```
directory-storing-JP1/Software-Distribution-commands/rdsdmrsc -r -s distributing-resource-name
```

Command to delete the status of distribution

```
directory-storing-JP1/Software-Distribution-commands/rdsdmind -r -a distributed-host-name -s distributing-resource-name
```

Replace *directory-storing-JP1/Software-Distribution-commands* with the following directory:

For HP-UX:

```
/opt/NETMDM/bin
```

For Solaris or AIX:

```
/usr/bin
```

11

Linking JP1/DH - AJE

This chapter describes how to define a job that uses JP1/DH - AJE to send and receive data.

11.1 Overview of linking JP1/DH - AJE

JP1/DH - AJE is a product that automates the process of transferring data to and from JP1/DH - Server. By linking with JP1/DH - AJE, you can define the sending and receiving of data in a JP1/AJS3 custom job, allowing you to incorporate data transfer into a series of operations performed by JP1/AJS3. You can also use a scheduler to automate the job, making operations that incorporate data transfer even more efficient.

To automate the sending and receiving of data as jobs, you need to define a custom job for JP1/DH - AJE in a jobnet and then execute the jobnet. To define such a custom job, JP1/DH - AJE (job definition program) must be installed on the JP1/AJS3 - View host, and JP1/DH - AJE (job execution program) must be installed on the host that will execute the custom job.

11.2 Setup for linking JP1/DH - AJE

When defining a custom job for JP1/DH - AJE in JP1/AJS3 - View, you need to install JP1/DH - AJE (job definition program) on the JP1/AJS3 - View host before you register the custom job in JP1/AJS3 - View. Also, JP1/DH - AJE (job execution program) must be installed on the host that will execute the custom job.

For details on how to install JP1/DH - AJE and register a custom job, see the manual *JP1/Data Highway - Automatic Job Executor*.

For details on how to register a custom job in JP1/AJS3 - View, see [3.2 Registering default custom jobs](#).

11.3 Sending and receiving data using JP1/ DH - AJE

To send and receive data using JP1/DH - AJE, register a custom job for JP1/DH - AJE and define it in a jobnet.

To register and define a custom job for JP1/DH - AJE:

1. In JP1/AJS3 - View, display the Jobnet Editor window for the jobnet you want to edit.
2. Select **Exclusive edit**.
3. Drag the icon of the custom job for JP1/DH - AJE from the icon list to the map area.
The Define Details - [Custom Job] dialog box appears.
4. Define the unit name and other attributes.
5. Click the **Details** button.
A dialog box appears in which you can define how data is to be sent and received. For details on the information you can set in this dialog box, see the manual *JP1/Data Highway - Automatic Job Executor*.
6. Click the **OK** button.
The dialog box closes.
7. In the Define Details - [Custom Job] dialog box, click **OK** button.
The Define Details - [Custom Job] dialog box closes.

12

Linking JP1/PFM

By linking JP1/PFM with JP1/AJS3, you can examine the cause of a problem with a JP1/AJS3 job due to system performance, and you can view the performance information about the manager host as a report. This chapter describes how to link JP1/PFM with JP1/AJS3.

12.1 Overview of linking JP1/PFM

The JP1/PFM product supports more stable system operation by collecting the operating information of various monitoring targets throughout the system, analyzing system performance, and identifying and resolving problems.

For example, by linking JP1/PFM with JP1/AJS3, you can pinpoint the cause of a job delay or job failure that occurred because of a problem with system performance.

12.2 Setup for linking JP1/PFM

The following figure shows an example of a system configuration for linking with JP1/PFM.

Figure 12–1: Example of a system configuration for linking with JP1/PFM

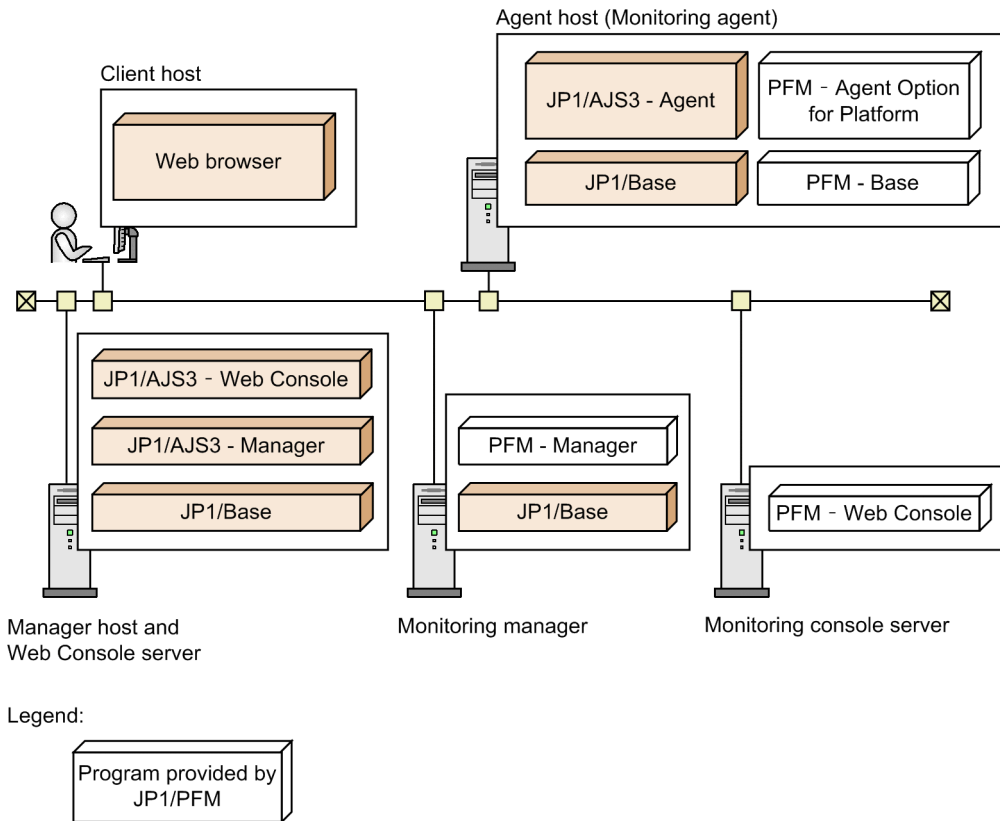

In the above example, PFM - Manager collects the operating status of the agent host (monitoring agent). The user who is logged in to PFM - Web Console from a web browser installed on the client host can monitor the operating status of the agent host. The user can also use a web browser on the client host to invoke PFM - Web Console from the Web GUI (Job Portal).

Cautionary note

For the monitoring host name of JP1/PFM, set the name of a manager host or agent host that is managed. Note the following when you set the host name:

If the monitoring target is a manager host:

In a physical host operating environment, set a real host name for the monitoring host name of JP1/PFM. In a logical host operating environment, set a logical host name for the monitoring host name of JP1/PFM.

Note that the monitoring host name of JP1/PFM cannot be specified in FQDN format. If the real host name has FQDN format, set an alias name for the monitoring host name of JP1/PFM.

If the monitoring target is an agent host:

For the monitoring host name of JP1/PFM, specify the execution host name that was specified when an execution agent was added.

Note that the monitoring host name of JP1/PFM cannot be specified in FQDN format. If the real host name has FQDN format, set an alias name for the monitoring host name of JP1/PFM. In this case, also set the same alias name for the execution host name.

To open the PFM - Web Console window from the Web GUI (Job Portal), set the following entries in the JP1/AJS3 - Web Console environment settings file:

- PFM_URL

The URL for accessing PFM - Web Console

- HOSTNAME_ALIAS_FOR_PFM

The JP1/AJS3 - Manager host alias name to be passed to PFM - Web Console[#]

#

For the host alias name, specify the alias name that is set for the monitoring host name of JP1/PFM.

For details about the setting item, see *3.4.3 Details on the settings in the environment-settings file (ajs3web.conf)* in the *JP1/Automatic Job Management System 3 Configuration Guide* (if the OS of the Web Console server is Windows), or *13.3.3 Details on settings in the environment-settings file (ajs3web.conf)* in the *JP1/Automatic Job Management System 3 Configuration Guide* (if the OS of the Web Console server is UNIX).

For details about installing and setting JP1/PFM, see *JP1/Performance Management Planning and Configuration Guide*. For details about building a system in which PFM - Manager collects the operating status of the JP1/AJS3 - Manager and JP1/AJS3 - Agent hosts, see the *JP1/Performance Management Planning and Configuration Guide*, and the *JP1/Performance Management User's Guide*.

12.3 Procedure for opening the PFM - Web Console window from the Web GUI (Job Portal)

The following shows the procedure for opening the PFM - Web Console window from the Web GUI (Job Portal).

1. In the Monitor dialog box or Monitor screen of the Web GUI (Job Portal), select a unit, and then click the **Detail** button.

The Detail Information dialog box appears.

2. Click the **Open PFM Report** button.

The PFM - Web Console screen appears.

Cautionary note

If the local date and time of the scheduler service have been changed, the job execution start and end times will be different from the actual system date and time. Therefore, the range of time indicated by the marker on the report screen in PFM - Web Console might be different from the time when the job was actually executed.

Appendixes

A. Monitoring Jobnets Using HP NNM

The following describes how to monitor JP1/AJS3 - Manager and JP1/AJS3 - Agent using HP NNM.

A.1 Overview of monitoring

HP NNM allows you to monitor the operation status of JP1/AJS3 - Manager, the execution status of jobs in jobnets, and the operation status of JP1/AJS3 - Agent. In addition, you can monitor a status that a user has reported.

This section describes what HP NNM can monitor for JP1/AJS3 - Manager and JP1/AJS3 - Agent.

This chapter refers to HP NNM as *NNM*.

What you can accomplish with NNM is explained separately for both JP1/AJS3 - Manager and JP1/AJS3 - Agent.

- With NNM, you can accomplish the following for JP1/AJS3 - Manager
 - Monitoring the operation status of JP1/AJS3 - Manager[#]

You can monitor the operation status of JP1/AJS3 - Manager using the symbols that are shown in the node submap in NNM.

In addition, you can obtain detailed information regarding the operation status from the messages shown in the Alarms Browser or another window.
 - Monitoring the execution status of jobs in jobnets[#]

You can monitor the execution status of jobs managed by JP1/AJS3 - Manager by utilizing the symbols shown in the node submap in NNM.

In addition, you can obtain detailed information regarding the execution status of jobs from the messages shown in the Alarms Browser or another window.
 - Monitoring a desired status[#]

NNM allows you to use symbols shown in the node submap to monitor a status that a user has reported, when the OpenView Status Report job is executed. In addition, you can obtain the words the user has reported from the messages shown in the Alarms Browser or another window.
 - Checking the operating environment of JP1/AJS3 - Manager

NNM allows you to check the operating environment of JP1/AJS3 - Manager (for example, the names of JP1/AJS3 services, operation status of JP1/AJS3 - Manager, the start time of operations, and other information).
 - Monitoring the status of executed jobnets

When you use NNM, you can activate JP1/AJS3 - View from NNM. You can monitor the status of executed jobnets managed by JP1/AJS3 - Manager using the Jobnet Monitor, Daily Schedule, and Monthly Schedule windows of JP1/AJS3 - View.

Note that JP1/AJS3 - View and version 08-00 or later of JP1/AJS2 - View do not support HP-UX or Solaris. You can only link to NNM from JP1/AJS3 - View and version 08-00 or later of JP1/AJS2 - View on a Windows system.
- With NNM, you can accomplish the following for JP1/AJS3 - Agent
 - Monitoring the operation status of JP1/AJS3 - Agent[#]

You can monitor the operation status of JP1/AJS3 - Agent by utilizing the symbols shown in the node submap of NNM.

In addition, you can obtain detailed information regarding the operation status from the messages shown in the Alarms Browser or another window.

- Monitoring a desired status[#]

NNM allows you to use symbols shown in the node submap to monitor a status that a user has reported, when the OpenView Status Report job is executed.

#

Before you start monitoring with symbols, you have to create the symbols you are going to use in NNM.

A.2 Setup for linking HP NNM (for a Windows host)

When linking HP NNM for monitoring of JP1/AJS3 - Manager and JP1/AJS3 - Agent from NNM, install either JP1/AJS3 - Manager or JP1/AJS3 - View in the host where NNM is installed.

The following figure shows an example of a system configuration for linking with HP NNM.

Figure A–1: Example of a system configuration for linking with HP NNM

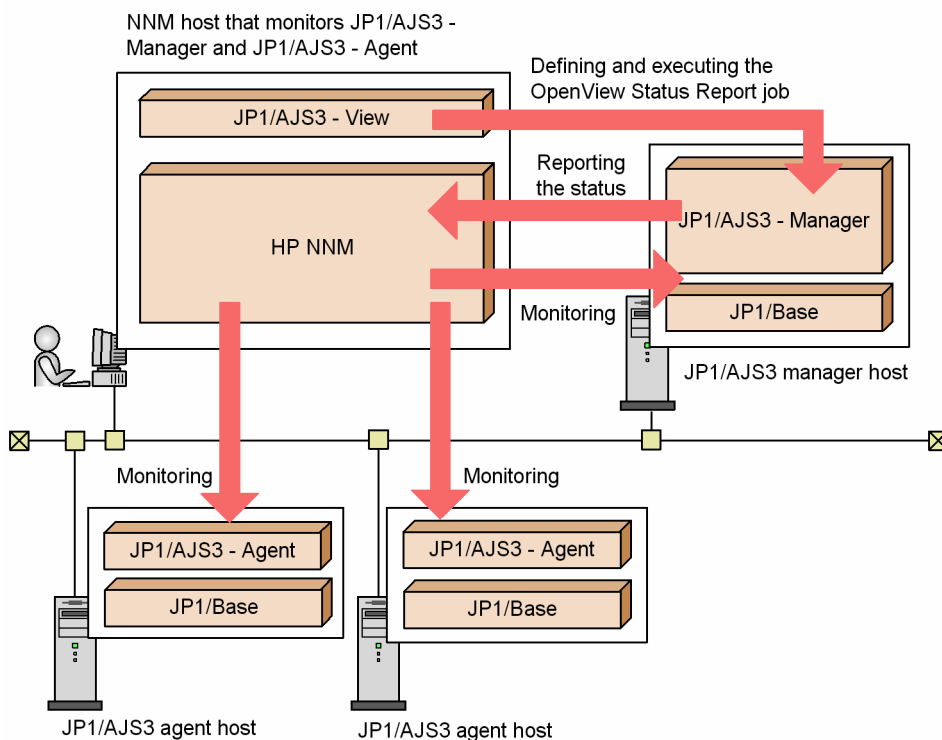

In this example, the *OpenView Status Report* action job is defined and executed using JP1/AJS3 - View for monitoring the status of JP1/AJS3 - Manager and JP1/AJS3 - Agent from NNM in the host where JP1/AJS3 - View is placed.

HP NNM can be linked using the operating systems listed below. If you use JP1/AJS3 as the NNM manager (monitoring host on which NNM is installed), note that NNM does not support the OS versions supported by JP1/AJS3 11-00 or later. To use JP1/AJS3 as the NNM manager, the version of JP1/AJS3 must be 10-50 or earlier.

When used as the NNM agent (the host monitored by NNM):

- Windows Server 2022^{#1}, Windows Server 2019^{#2}, Windows Server 2016^{#2}, Windows Server 2012^{#3}, or Windows Server 2012 R2^{#4}
(JP1/AJS3 - Manager or JP1/AJS3 - Agent)

#1

HP NNM can be used when the version of JP1/AJS3 - Manager or JP1/AJS3 - Agent is 12-50 or later.

#2

HP NNM can be used when the version of JP1/AJS3 - Manager or JP1/AJS3 - Agent is 11-10 or later.

#3

HP NNM can be used when the version of JP1/AJS3 - Manager is 10-00-02 or later or the version of JP1/AJS3 - Agent is 10-00-03 or later.

#4

HP NNM can be used when the version of JP1/AJS3 - Manager or JP1/AJS3 - Agent is 10-00-06 or later.

Supplementary note

When JP1/AJS3 sends SNMP traps as an NNM agent, JP1/AJS3 use the Windows SNMP service to obtain the destinations of the SNMP traps.

The Windows SNMP service is therefore a prerequisite for sending SNMP traps.

The following figure shows the setup procedure for linking HP NNM.

Figure A–2: Setup procedure for linking HP NNM

- NNM host that monitors JP1/AJS3 - Manager and JP1/AJS3 - Agent

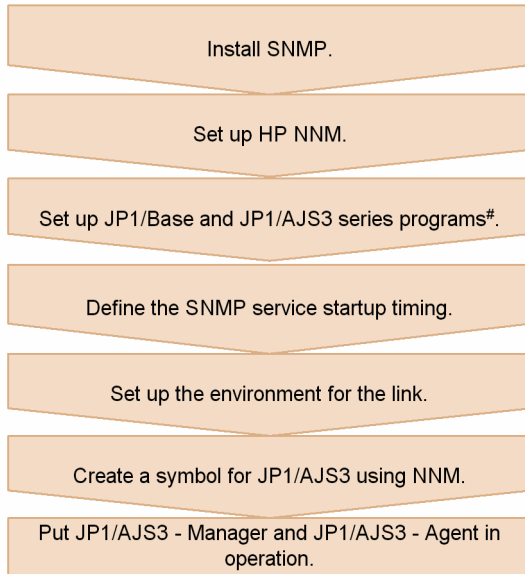

- Host for JP1/AJS3 manager host and JP1/AJS3 agent host to be monitored

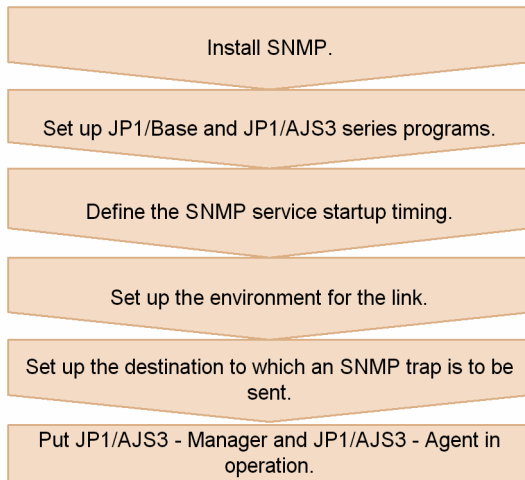

If only JP1/AJS3 - View is installed, JP1/Base need not be set up.

For further details regarding the setup of HP NNM, see the documentation for HP NNM.

The subsections below describe how to define the SNMP service startup timing and environment settings for a link.

(1) Defining the SNMP service startup timing

To issue an SNMP trap correctly when starting up or terminating the JP1/AJS3 service, set up the order in which the SNMP service or NNM and the JP1/AJS3 service are activated.

To specify the order of startup, use the startup management function of JP1/Base.

In the host in which NNM is set up, specify the startup so that NNM is activated first and JP1/AJS3 service is activated next. In the host to be monitored by NNM, specify the startup so that the SNMP service is activated first, followed by the JP1/AJS3 service.

For details on the startup management function of JP1/Base, see the *JP1/Base User's Guide*.

! Important

If the HP NNM service has not been activated in the host where NNM is set up when an SNMP trap is issued, the trap might not be reported. The issued SNMP trap also might not be reported depending on the network status because it uses the UDP protocol. The SNMP trap also might not be reported depending on its characteristics. When this occurs, note that SNMP traps are issued but might not be reflected in NNM.

(2) Setting up the environment for the link

If the status of the scheduler is to be monitored, it necessary to set up a monitoring process that monitors the status of the scheduler at 5-minute intervals and, when the status changes, issues `snmptrap`. To set up a monitoring process, edit the `jplajs_hstd.conf` file as shown below. Note that you need to specify the settings for monitoring the scheduler status only if you want to monitor the scheduler status. You do not need to specify those settings for JP1/AJS3 - Agent.

- If the `jplajs_hstd.conf` file has been altered to set up a standard configuration without ISAM or to configure a queueless job execution environment:

Back up the `jplajs_hstd.conf` file, and then append the following line to the end of the file:

```
ajsovstatd|ajsovstatd.exe|||1800|
```

- In all other scenarios:

Back up the `jplajs_hstd.conf` file, and then replace the `jplajs_hstd.conf` with the `jplajs_hstd_ov.conf.model` file.

The `jplajs_hstd.conf` file is stored in the `JP1/AJS3-installation-folder\conf` folder.

To change the SNMP traps to be sent for linkage with HP NNM according to the operating environment, set the required environment setting parameters in the JP1/Base common definition and in the environment definition file for linkage with HP NNM. The following table lists the environment setting parameters required for linkage with HP NNM.

Table A–1: List of environment setting parameters for linkage with HP NNM

Location	Parameter name	Description	
Common definition	[JP1_DEFAULT\JP1AOMAGENT\ov_link]	"TRAPRESTRAIN"=	This parameter sets whether to suppress sending SNMP traps. ^{#1}
	[{JP1_DEFAULT logical-host-name}\JP1AOMAGENT\ov_link]	"SNMPTRAPCUSTOM"=	This parameter sets the reference level for customization information during SNMP trap sending. ^{#2}
		"TRAPAGENTADDRHOST"=	This parameter sets the name of the host that sends SNMP traps. ^{#2}
		"TRAPAGENTADDRIP"=	This parameter sets the IP address of the host that sends SNMP traps. ^{#2}
	"CUSTOMCOMMUNITY"=	This parameter sets the community name for authenticating SNMP traps (on the NNM agent side). ^{#2}	

#1

For details about this environment setting parameter, see (4) [Disabling SNMP trap transmission](#).

#2

For details about this environment setting parameter, see (5) [Customizing the SNMP trap to be sent](#).

(3) Setting up SNMP trap destinations

In the host (where JP1/AJS3 - Manager or JP1/AJS3 - Agent to be monitored is installed) monitored by NNM, it is necessary to set up the community name of the SNMP service and the destination to which the trap is to be sent. The community name must be `Jp1Trap`, and the destination to which the trap is to be sent must be the host name of the manager (where NNM is installed) or one or more IP addresses.

If the NNM agent is to be managed in a cluster system, each node must have a monitoring host specified as the destination to which the trap is to be sent.

(4) Disabling SNMP trap transmission

The JP1/AJS3 service transmits SNMP traps that are used for JP1/AJS3 objects to NNM. To disable SNMP trap transmission from JP1/AJS3, you must specify it in the JP1/Base common definition information, using the following procedure. To disable SNMP trap transmission:

1. Execute the following command:

```
jajs_config -k "[JP1_DEFAULT\JP1AOMAGENT\ov_link]" "TRAPRESTRAIN"="Y"
```

In the `TRAPRESTRAIN` parameter, specify whether to disable SNMP trap transmission. If you want to disable SNMP trap transmission, specify `Y`. If you do not want to disable it, specify `N`. The default is `N`. If you do not want to disable SNMP trap transmission, substitute `N` for `Y` in the following information. If you specify any value other than `Y` or `N`, an error will occur during trap transmission.

(5) Customizing the SNMP trap to be sent

(a) Customizing the send source host name

For sending SNMP traps for JP1/AJS3 objects, the name and IP address of a physical host are generally set for the send source host. If the host sending SNMP traps has more than one IP address, you may have to explicitly specify the name of the send source host. Specify the name of the host sending SNMP traps in the following cases:

- When NNM is set not to recognize the logical host, a clustered JP1/AJS3 node might send an SNMP trap for which the logical host name is set as the send source host name. In this case, set the physical host name as the send source host name.
- When NNM is set to recognize the logical host, a clustered JP1/AJS3 node might send an SNMP trap for which the physical host name is set as the send source host name. In this case, set the logical host name as the send source host name.

To customize the name of the host sending the SNMP trap to be sent, you need to set up the JP1/Base common definition information so that the customization information is referenced when the SNMP trap is sent.

■ Setting procedure

To customize the SNMP trap:

1. Execute the following command to set the environment setting parameters.

```
jajs_config -k definition-key-name "environment-setting-parameter-1"=definition-content-1  
[ "environment-setting-parameter-2"=definition-content-2 ]  
[ "environment-setting-parameter-3"=definition-content-3 ]
```

■ List of environment setting parameters

Table A–2: Environment setting parameters for customizing the send source host name

Definition key	Environment setting parameter	Defined information
[{JP1_DEFAULT <i>logical-host-name</i> } \JP1AOMAGENT\ov_link] #1	"SNMPTRAPCUSTOM"=#2	dword: {0 1 2}
	"TRAPAGENTADDRHOST"=#3	" <i>agent-host-name</i> "
	"TRAPAGENTADDRIP"=#4	" <i>IP-address</i> "

#1

The {JP1_DEFAULT | *logical-host-name*} part indicates that you must specify JP1_DEFAULT for the physical host and *logical-host-name* for the logical host.

#2

The SNMPTRAPCUSTOM environment settings parameter specifies whether to reference the customization information when the SNMP trap is sent. Specify 1 to reference the send source host name. Otherwise, specify 0. The default is 1.

#3

In the TRAPAGENTADDRHOST environment settings parameter, specify the name of the host that sends the SNMP trap. Use up to 255 bytes. The default is the name of the physical host that sends the SNMP trap.

#4

In the TRAPAGENTADDRIP environment settings parameter, specify the IP address of the host that sends the SNMP trap. The default is the IP address of the physical host that sends the SNMP trap.

(b) Customizing the community name for authentication

■ Customizing the community name for authenticating the SNMP traps on the status-monitored host (where JP1/AJS3 is installed)

You may want to customize the community name for authenticating the SNMP traps for the JP1/AJS3 objects of the status-monitored host (where JP1/AJS3 is installed). To do this, specify the settings for referencing the customization information in the JP1/Base common definition.

To specify the settings for referencing the customization information in the JP1/Base common definition:

1. Execute the following command to set the environment setting parameters.

```
jajs_config -k definition-key-name "environment-setting-parameter-1"=definition-content-1
["environment-setting-parameter-2"=definition-content-2]
```

Table A–3: Environment setting parameters for customizing the community name for authentication

Definition key	Environment setting parameter	Defined information
[{JP1_DEFAULT <i>logical-host-name</i> } \JP1AOMAGENT\ov_link] #1	"SNMPTRAPCUSTOM"=#2	dword: {0 1 2}
	"CUSTOMCOMMUNITY"=#3	" <i>community-name-for-authentication</i> "

#1

The {JP1_DEFAULT | *logical-host-name*} part indicates that you must specify JP1_DEFAULT for the physical host and *logical-host-name* for the logical host.

#2

The SNMPTRAPCUSTOM environment settings parameter specifies whether to reference the customization information when the SNMP trap is sent. Specify 2 to reference the community name for authentication. The default is 1.

In the `CUSTOMCOMMUNITY` environment settings parameter, specify the community name for authentication. Use up to 255 bytes. The default is `public`.

Cautionary notes

- To customize both the send source host name and the community name for authentication, specify 2 for the `SNMPTRAPCUSTOM` parameter and specify either the `TRAPAGENTADDRHOST` or `TRAPAGENTADDRIP` parameter with the `CUSTOMCOMMUNITY` parameter.
- To use NNM for the Windows host to receive the customized SNMP trap, you must set up NNM so that it will not use WinSNMP. For details, see the description of `ovtrapd` in NNM Run-time Help.

(6) Unlinking HP NNM

To disable linkage with HP NNM on the monitored side (where JP1/AJS3 is installed), from the list of trap destinations in the SNMP service settings, delete the host on which NNM is installed.

(7) Cautionary notes on linking HP NNM

(a) General notes

- We recommend that you set up NNM so that it will not recognize a logical host when monitoring nodes in a cluster system. Because the JP1/AJS3 trap is transmitted with a physical host name specified as a key, no JP1/AJS3 symbol can be displayed if NNM recognizes the nodes by logical host names. When linking JP1/AJS3 with HP NNM, set up NNM in such a way that it will not recognize logical hosts or customize the SNMP trap to be sent.

For details on how to customize the SNMP trap to be sent, see [\(5\) Customizing the SNMP trap to be sent](#). For details on how to set up NNM, see the documentation for HP NNM.

- If an SNMP trap contains text whose character encoding is different from the NNM language environment, the reported data is corrupted and will not be displayed correctly in Alarms Browser. Therefore, make sure that the language environment settings of NNM and JP1/AJS3 match if you use multi-byte characters for the following items:
 - **Root jobnet name**
This information is included in an SNMP trap issued when a root jobnet terminates abnormally.
 - **Additional information** for the OpenView Status Report Job
This information is included in an SNMP trap issued when the OpenView Status Report Job is executed.

(b) Cautionary notes for the NNM agent side

- If the agent host uses a long host name due to the presence of a DNS or some other reason, ensure that the name of the monitored host (the host where JP1/AJS3 is installed) does not exceed 228 bytes.
In addition, when JP1/AJS3 on a logical host is monitored, the sum of the lengths of the physical host name and the logical host name must not exceed 246 bytes.
If the host names exceed this length, symbols are not created in NNM.
- An SNMP trap that notifies an abnormal termination of a jobnet is sent when the root jobnet terminates abnormally.

A.3 Setup for linking HP NNM (for a UNIX host)

When linking HP NNM for monitoring of JP1/AJS3 - Manager and JP1/AJS3 - Agent from NNM, install either JP1/AJS3 - Manager or JP1/AJS3 - View in the host where NNM is installed.

The following figure shows an example of a system configuration for linking with HP NNM.

Figure A-3: Example of a system configuration for linking with HP NNM

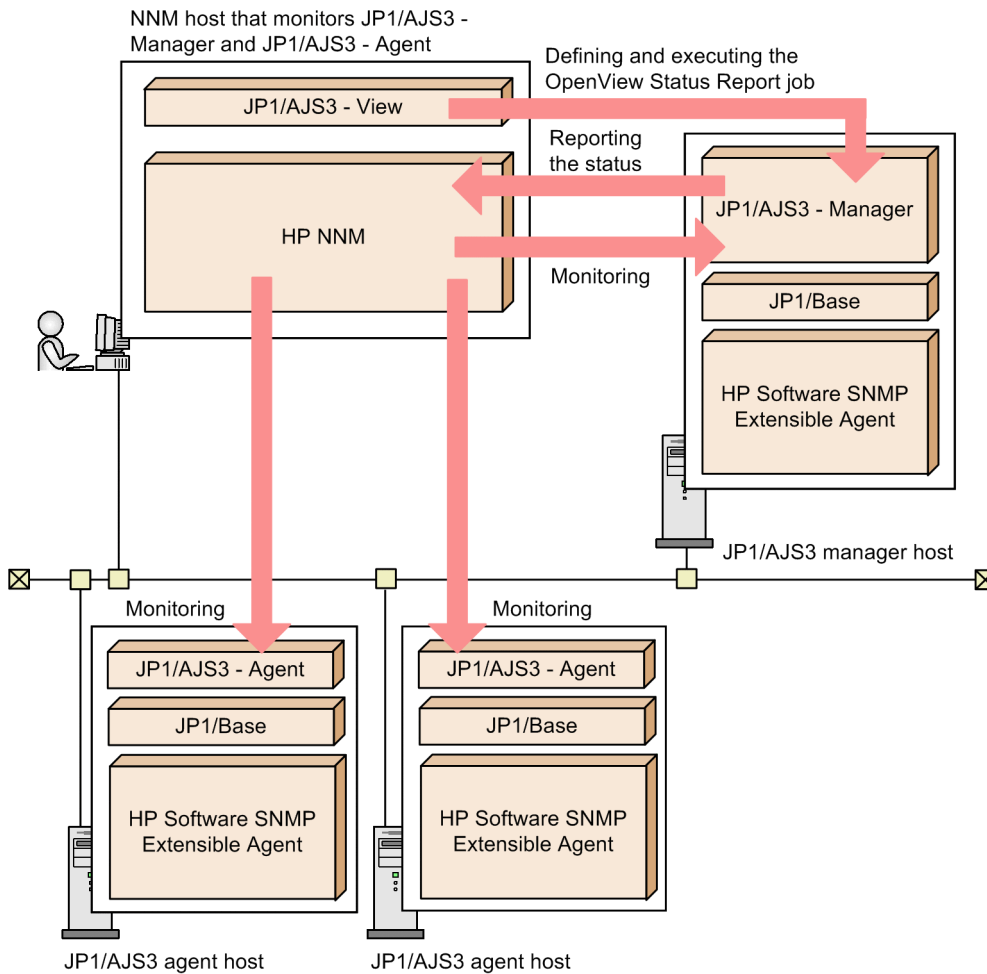

In this example, the *OpenView Status Report* action job is defined and executed using JP1/AJS3 - View installed in the Windows host for monitoring the status of JP1/AJS3 - Manager and JP1/AJS3 - Agent from NNM in the host where JP1/AJS3 - View is placed.

HP NNM can be linked using the operating systems listed below. Note that if you use a JP1/AJS3 host as an NNM manager (monitoring host on which NNM is installed), JP1/AJS3 12-00 or later supports no OS that allows use as an NNM manager. To use a JP1/AJS3 host as an NNM manager, make sure that the version of JP1/AJS3 is 11-50 or earlier.

OSs that can be used for NNM agents (hosts monitored by NNM) are as follows:

- Solaris
(JP1/AJS3 - Manager or JP1/AJS3 - Agent)
- AIX
(JP1/AJS3 - Manager or JP1/AJS3 - Agent)
- Linux
(JP1/AJS3 - Manager or JP1/AJS3 - Agent)

Supplementary note

JP1/AJS3 uses the following functions and files of Job Management Partner 1/Consolidated Management 2/ Extensible SNMP Agent or HP Software Extensible SNMP Agent as the NNM agent:

- SNMP trap destination referencing
- `snmptrap` command
- Extensible MIB definition file

For this reason, Job Management Partner 1/Consolidated Management 2/Extensible SNMP Agent or HP Software Extensible SNMP Agent is required as a prerequisite program.

The following figure shows the setup procedure for linking HP NNM.

Figure A–4: Setup procedure for linking HP NNM

- NNM host that monitors JP1/AJS3 - Manager and JP1/AJS3 - Agent

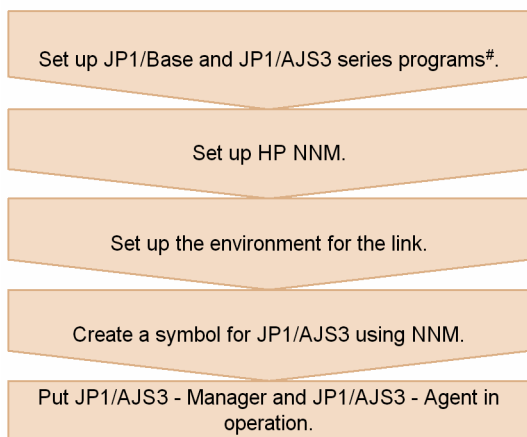

- Host for JP1/AJS3 manager host and JP1/AJS3 agent host to be monitored

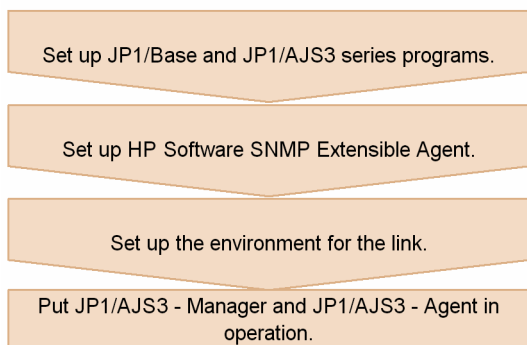

If only JP1/AJS3 - View is installed in a host, JP1/Base need not be set up in the host.

For details on how to set up HP NNM, see the relevant manual or the HP NNM documentation.

For details on setting up Job Management Partner 1/Consolidated management 2/Extensible SNMP Agent or HP Software Extensible SNMP Agent, see the manual *Job Management Partner 1/Consolidated Management 2/Extensible SNMP Agent* or the HP NNM document.

The subsections below describe environment settings for a link.

(1) Setting up the environment for the link

To link with HP NNM, use the `ajsosetup` command to set up the environment for the link. Execute the command on both the monitoring side (that is, the host where NNM is installed) and the monitored side (the host where JP1/AJS3 - Manager or JP1/AJS3 - Agent is installed).

If the status of the scheduler is to be monitored, it is necessary to set up a monitoring process that monitors the status of the scheduler at 5-minute intervals and, when the status changes, issues `snmptrap`. To set up a monitoring process, edit the `jplajs_hstd.conf` file as shown below. However, if JP1/AJS3 - Agent is installed or the status of the scheduler is not to be monitored, you do not need to specify the settings for monitoring the scheduler status.

- If the `jplajs_hstd.conf` file has been altered for a purpose such as setting up a standard configuration without ISAM

Back up the `jplajs_hstd.conf` file, and then append the following line to the end of the file:

```
ajsostatd|/opt/jplajs2/bin/ajsostatd||1800|
```

- In all other scenarios:

Back up the `jplajs_hstd.conf` file, and then replace the `jplajs_hstd.conf` with the `jplajs_hstd_ov.conf.model` file.

The `jplajs_hstd.conf` file is stored in the `/etc/opt/jplajs2/conf` directory.

To change the SNMP traps to be sent for linkage with HP NNM according to the operating environment, set the required environment setting parameters in the JP1/Base common definition and in the environment definition file for linkage with HP NNM. The following table lists the environment setting parameters required for linkage with HP NNM.

Table A-4: List of environment setting parameters for linkage with HP NNM

Location	Parameter name	Description	
Common definition	[JP1_DEFAULT\JP1AOMAGENT\ov_link]	"TRAPRESTRAIN"=	This parameter sets whether to suppress sending SNMP traps. ^{#1}
	[{JP1_DEFAULT logical-host-name}\JP1AOMAGENT\ov_link]	"SNMPTRAPCUSTOM"=	This parameter sets the reference level for customization information during SNMP trap sending. ^{#2}
		"TRAPAGENTADDRHOST"=	This parameter sets the name of the host that sends SNMP traps. ^{#2}
		"TRAPAGENTADDRIP"=	This parameter sets the IP address of the host that sends SNMP traps. ^{#2}
		"CUSTOMCOMMUNITY"=	This parameter sets the community name for authenticating SNMP traps (on the NNM agent side). ^{#2}

#1

For details about this environment setting parameter, see (2) [Disabling SNMP trap transmission](#).

#2

For details about this environment setting parameter, see (3) [Customizing the SNMP trap to be sent](#).

(2) Disabling SNMP trap transmission

The JP1/AJS3 service transmits SNMP traps that are used for JP1/AJS3 objects to NNM. To disable SNMP trap transmission from JP1/AJS3, you must specify it in the JP1/Base common definition information, using the following procedure. To disable SNMP trap transmission:

1. Execute the following command:

```
jajs_config -k "[JP1_DEFAULT\JP1AOMAGENT\ov_link]" "TRAPRESTRAIN"="Y"
```

In the TRAPRESTRAIN parameter, specify whether to disable SNMP trap transmission. If you want to disable SNMP trap transmission, specify Y. If you do not want to disable it, specify N. The default is N. If you do not want to disable SNMP trap transmission, substitute N for Y in the following information. If you specify anything other than Y or N, an error will occur during trap transmission.

(3) Customizing the SNMP trap to be sent

(a) Customizing the send source host name

For sending SNMP traps for JP1/AJS3 objects, the name and IP address of a physical host are generally set for the send source host. If the host sending SNMP traps has more than one IP address, you may have to explicitly specify the name of the send source host. Specify the name of the host sending SNMP traps in the following cases:

- When NNM is set not to recognize the logical host, a clustered JP1/AJS3 node might send an SNMP trap for which the logical host name is set as the send source host name. In this case, set the physical host name as the send source host name.
- When NNM is set to recognize the logical host, a clustered JP1/AJS3 node might send an SNMP trap for which the physical host name is set as the send source host name. In this case, set the logical host name as the send source host name.

To customize the name of the host sending the SNMP trap to be sent, you need to set up the JP1/Base common definition information so that the customization information is referenced when the SNMP trap is sent.

■ Setting procedure

To customize the SNMP trap:

1. Execute the following command to set the environment setting parameters.

```
jajs_config -k definition-key-name "environment-setting-parameter-1"=definition-content-1
["environment-setting-parameter-2"=definition-content-2]
["environment-setting-parameter-3"=definition-content-3]
```

■ List of environment setting parameters

Table A-5: Environment setting parameters for customizing the send source host name

Definition key	Environment setting parameter	Defined information
[{JP1_DEFAULT logical-host-name} \JP1AOMAGENT\ov_link] #1	"SNMPTRAPCUSTOM"=#2	dword: {0 1 2}
	"TRAPAGENTADDRHOST"=#3	"agent-host-name"
	"TRAPAGENTADDRIP"=#4	"IP-address"

#1 The {JP1_DEFAULT | logical-host-name} part indicates that you must specify JP1_DEFAULT for the physical host and logical-host-name for the logical host.

#2 The SNMPTRAPCUSTOM environment settings parameter specifies whether to reference the customization information when the SNMP trap is sent. Specify 1 to reference the send source host name. Otherwise, specify 0. The default is 1.

#3 In the TRAPAGENTADDRHOST environment settings parameter, specify the name of the host that sends the SNMP trap. Use up to 255 bytes. The default is the name of the physical host that sends the SNMP trap.

#4

In the `TRAPAGENTADDRIP` environment settings parameter, specify the IP address of the host that sends the SNMP trap. The default is the IP address of the physical host that sends the SNMP trap.

(b) Customizing the community name for authentication

SNMP traps for JP1/AJS3 objects use `public` as the community name for authentication. To customize the community name for authenticating the send SNMP traps, you must specify the settings so that the customization information be referenced during sending of SNMP traps.

■ Customizing the community name for authenticating the SNMP traps on the status-monitored host (where JP1/AJS3 is installed)

To customize the community name to authenticate the SNMP traps for JP1/AJS3 objects on the status-monitored host (where JP1/AJS3 is installed), specify the settings for referencing the customization information in the JP1/Base common definition. The procedure is as follows.

To customize the community name for authenticating the SNMP traps on the status-monitored host:

1. Execute the following command to set the environment setting parameters.

```
jaajs_config -k definition-key-name "environment-setting-parameter-1"=definition-content-1
[ "environment-setting-parameter-2"=definition-content-2 ]
```

Table A–6: Environment setting parameters for customizing the send source host name

Definition key	Environment setting parameter	Defined information
[{JP1_DEFAULT <i>logical-host-name</i> } \JP1AOMAGENT\ov_link] #1	"SNMPTRAPCUSTOM"=#2	dword: {0 1 2}
	"CUSTOMCOMMUNITY"=#3	" <i>community-name-for-authentication</i> "

#1

The {JP1_DEFAULT|*logical-host-name*} part indicates that you must specify JP1_DEFAULT for the physical host and *logical-host-name* for the logical host.

#2

The `SNMPTRAPCUSTOM` environment settings parameter specifies whether to reference the customization information when the SNMP trap is sent. Specify 2 to reference the community name for authentication. The default is 1.

#3

In the `CUSTOMCOMMUNITY` environment settings parameter, specify the community name for authentication. Use up to 255 bytes. The default is `public`.

Cautionary notes

- To customize both the send source host name and the community name for authentication, specify 2 for the `SNMPTRAPCUSTOM` parameter and specify either the `TRAPAGENTADDRHOST` or `TRAPAGENTADDRIP` parameter with the `CUSTOMCOMMUNITY` parameter.
- To use NNM for the Windows host to receive the customized SNMP trap, you must set up NNM so that it will not use WinSNMP. For details, see the description of `ovtrapd` in NNM Run-time Help.

(4) Unlinking HP NNM

To unlink HP NNM on the monitored side (where JP1/AJS3 is installed), use the following procedure.

To unlink HP NNM on the monitored side:

1. To disable SNMP trap transmission, you must specify it.
For details on how to disable SNMP trap transmission, see (2) *Disabling SNMP trap transmission*.
2. Execute the `ajsremove` command.

(5) Cautionary notes on linking HP NNM

(a) General notes

- We recommend that you set up NNM so that it will not recognize a logical host when monitoring nodes in a cluster system. Because the JP1/AJS3 trap is transmitted with a physical host name specified as a key, no JP1/AJS3 symbol can be displayed if NNM recognizes the nodes by logical host names. When linking JP1/AJS3 with HP NNM, set up NNM in such a way that it will not recognize logical hosts or customize the SNMP trap to be sent.
For details on how to customize the SNMP trap to be sent, see (3) *Customizing the SNMP trap to be sent*. For details on how to set up NNM, see the HP NNM documentation.
- If an SNMP trap contains text whose character encoding is different from the NNM language environment, the reported data is corrupted and will not be displayed correctly in Alarms Browser. Therefore, make sure that the language environment settings of NNM and JP1/AJS3 match if you use multi-byte characters for the following items:
 - Root jobnet name
This information is included in an SNMP trap issued when a root jobnet terminates abnormally.
 - **Additional information** for the OpenView Status Report Job
This information is included in an SNMP trap issued when the OpenView Status Report Job is executed.
- The following table shows the NNM files configured in JP1/AJS3.

Table A–7: The NNM files configured in JP1/AJS3

Purpose of file	File names
Trap action definition	<code>/etc/opt/OV/share/conf/\$LANG/trapd.conf</code>
Field definition	<code>/etc/opt/OV/share/fields/C/jplajs2_f</code>
Application definition	<code>/etc/opt/OV/share/registration/\$LANG/jplajs2</code>
Trusted command definition	<code>/etc/opt/OV/share/conf/trustedCmds.conf/trustajs2</code>
Extended user MIB definition	<code>/etc/SnmpAgent.d/snmpd.extend</code>

Do not modify these files from their original state. Symbols might not display in NNM if these files are modified.

(b) Cautionary notes for the NNM agent side

- SNMP traps might fail to send if the process that controls the sending of SNMP traps is inactive, for example. Because different software controls the sending of SNMP traps in different ways, the cause of the error might differ depending on the software. On the host from which SNMP traps are sent (the host where JP1/AJS3 is installed), make sure that SNMP traps can be sent correctly.
- If the agent host uses a long host name due to the presence of a DNS or some other reason, ensure that the name of the monitored host (the host where JP1/AJS3 is installed) does not exceed 228 bytes.
In addition, if JP1/AJS3 on a logical host is monitored, the sum of the lengths of the physical host name and the logical host name must not exceed 246 bytes.
If the host names exceed this length, symbols are not created in NNM.

- When the `ajsovsetup` command is executed, JP1/AJS3 MIB definition information is added to the extended MIB definition file. When the `ajsovremove` command is executed, JP1/AJS3 MIB definition information is deleted from the extended MIB definition file. Note that the changes to the extended MIB definition file are applied when the SNMP agent is restarted.

For details about restarting the SNMP agent, see the *Job Management Partner 1/Consolidated Management 2/Extensible SNMP Agent Description, Operator's Guide and Reference*.

- An SNMP trap that notifies an abnormal termination of a jobnet is sent when the root jobnet terminates abnormally.

A.4 SNMP traps

This section describes SNMP traps used when monitoring JP1/AJS3 - Manager and JP1/AJS3 - Agent.

(1) Defining objects

Objects are classified into two types:

- Objects representing the status of JP1/AJS3 (objects representing the operation status of JP1/AJS3 - Manager, execution status of jobs in jobnets, and operation status of JP1/AJS3 - Agent)
- Objects representing a status that a user has reported

(a) Objects representing the status of JP1/AJS3

The following describes the selection name and symbol attribute of objects representing the status of JP1/AJS3:

■ Selection name

Format

host-name:logical-host-name-JP1AJS2

host-name

In *host-name*, the host name for JP1/AJS3 - Manager or JP1/AJS3 - Agent is set.

logical-host-name

In *logical-host-name*, the logical host name for JP1/AJS3 - Manager or JP1/AJS3 - Agent is set.

If they do not have a logical host name, JP1_DEFAULT is set.

■ Symbol attributes

The following table lists the attributes of the **JP1AJS2** symbol:

Table A–8: JP1AJS2 symbol attributes

Attribute	Description
Label	JP1AJS2 (or <i>logical-host-name-JP1AJS2</i> only when JP1/AJS3 has a logical host name)
Icon symbol class	Software:Process
Status source	Object status
Operation of symbol	Executable
Action	Activates JP1/AJS3 - View.

(b) Objects representing a status that a user has reported

The following describes the format of the objects representing a status that a user has reported:

■ Selection name

Format

host-name:logical-host-name-AJS2USER

host-name

In *host-name*, the host name for JP1/AJS3 - Manager or JP1/AJS3 - Agent is set.

logical-host-name

In *logical-host-name*, the logical host name for JP1/AJS3 - Manager or JP1/AJS3 - Agent is set.

If they do not have a logical host name, JP1_DEFAULT is set.

■ Symbol attributes

The following table lists the attributes of the **AJS2USER** symbol:

Table A–9: AJS2USER symbol attributes

Attribute	Description
Label	AJS2USER
Icon symbol class	Software:Process
Status source	Object status
Operation of symbol	Not executable
Action	None

(c) Detailed event definition

See Tables [A-10](#) to [A-12](#) for detailed event definition information for the following three traps:

- Jp1ajs2_Sts_Report
- Jp1ajs2_Sts_Caution
- Jp1ajs2_Err_Jobnet

Table A–10: Detailed event definition (trap name: Jp1ajs2_Sts_Report)

Item	Description
Trap name	Jp1ajs2_Sts_Report
Object ID	.1.3.6.1.4.1.116.7.17.10
Extended trap ID	6
Severity	1
Message format [#]	\$A:\$2-\$5 Status change to \$7.(\$8)
Message details	This trap is reported for JP1/Automatic Job Management System 2 status changed.

#

The parameters in the message are:

\$A: Host name

\$2: JP1 host name
 \$5: Label name
 \$7: Status
 \$8: Additional information

Table A–11: Detailed event definition (trap name: Jp1ajs2_Sts_Caution)

Item	Description
Trap name	Jp1ajs2_Sts_Caution
Object ID	.1.3.6.1.4.1.116.7.17.10
Extended trap ID	6
Severity	2
Message format [#]	\$A:\$2-\$5 Status change to \$7.(\$8)
Message details	This trap is reported for JP1/Automatic Job Management System 2 status changed.

#

The parameters in the message are:

\$A: Host name
 \$2: JP1 host name
 \$5: Label name
 \$7: Status
 \$8: Additional information

Table A–12: Detailed event definition (trap name: Jp1ajs2_Err_Jobnet)

Item	Description
Trap name	Jp1ajs2_Err_Jobnet
Object ID	.1.3.6.1.4.1.116.7.17.10
Extended trap ID	6
Severity	21
Message format [#]	\$A: \$2-\$5 Jobnet terminates abnormally. (\$3:\$4)
Message details [#]	This trap is reported that jobnet terminates abnormally on JP1/Automatic Job Management System 2. (\$3: AJS service name, \$4: Jobnet name)

Note

The Jp1ajs2_Err_Jobnet trap reports the abnormal end of a root jobnet to **Error alarm**. This trap does not change the status of the **JP1AJS2** symbol.

#

The parameters in the message are:

\$A: Host name
 \$2: JP1 host name
 \$3: AJS service name
 \$4: Jobnet name
 \$5: Label name

(d) Additional fields

The following table describes additional fields:

Table A–13: Additional fields

Field name	Type	Flag	Description
isJP1NNM	boolean	capability	Indicates whether a management object is of the JP1 series or not. 0: Not a management object of JP1 series 1: A management object of JP1 series
isJP1AJS2	boolean	capability	Indicates whether a management object is of JP1/AJS3 or not. 0: Not a management object of JP1/AJS3 1: A management object of JP1/AJS3
isJP1AJS2Submap	boolean	capability	Indicates whether the object managed by JP1/AJS3 has a submap. 0: Does not have a submap. 1: Has a submap.
isJP1AJS2Action	boolean	capability	Indicates whether the symbol managed by JP1/AJS3 has an action. 0: Does not have an action. 1: Has an action.
isJP1AJS2Type	boolean	capability	Indicates the type of symbol managed by JP1/AJS3. 0: JP1AJS2 symbol 1: AJS2USER symbol
isJP1AJS2Del	boolean	capability	Indicates whether the object managed by JP1/AJS3 has been deleted. 0: Has not been deleted. 1: Has been deleted.
jplajs2 Control	Enumeration	capability	Indicates who controls the object managed by JP1/AJS3. jplajs2 JP1/AJS3 management spm Process management queue Queuing schedule Scheduler evactionm Event action control manager evactiona Event action control agent
jplajs2 Status	Enumeration	capability	Indicates the status of the symbol managed by JP1/AJS3. <ul style="list-style-type: none"> • Unknown • Normal • Warning • Minor • Major • Critical • Restricted • Testing • Disabled

Field name	Type	Flag	Description
jplajs2 SymbolType	Enumeration	capability	Indicates the symbol type of the symbol managed by JP1/AJS3. Software:Process Software process
jplajs2 HostName	string	general	Indicates the host name of the instance of JP1/AJS3 being monitored.
jplajs2 jplHostName	string	general	Indicates the logical host name of the instance of JP1/AJS3 being monitored.
isJP1AJS2ObjExist	boolean	capability	Indicates whether the management object of JP1/AJS3 associates with the map. (Used for a context function) 0: The management object of JP1/AJS3 does not exist. 1: The management object of JP1/AJS3 exists.
jplajs2 AJSServiceName n (n is a value between 1 and 9. 9 fields in total)	string	general	Indicates the service name of the instance of JP1/AJS3 being monitored.
jplajs2 Status AJSServ n (n is a value between 1 and 9. 9 fields in total)	Enumeration	capability	Indicates the status of object managing of the JP1/AJS3 service. <ul style="list-style-type: none"> • Unknown • Normal • Warning • Minor • Major • Critical • Restricted • Testing • Disabled

A.5 MIB objects (UNIX only)

When an environment for using HP NNM linkage is set up in JP1/AJS3 - Manager on a UNIX host, jobnet statistical information is registered in MIB objects.

The following figure illustrates the configuration of MIB objects in which jobnet statistical information is registered.

Figure A–5: Configuration of MIB objects

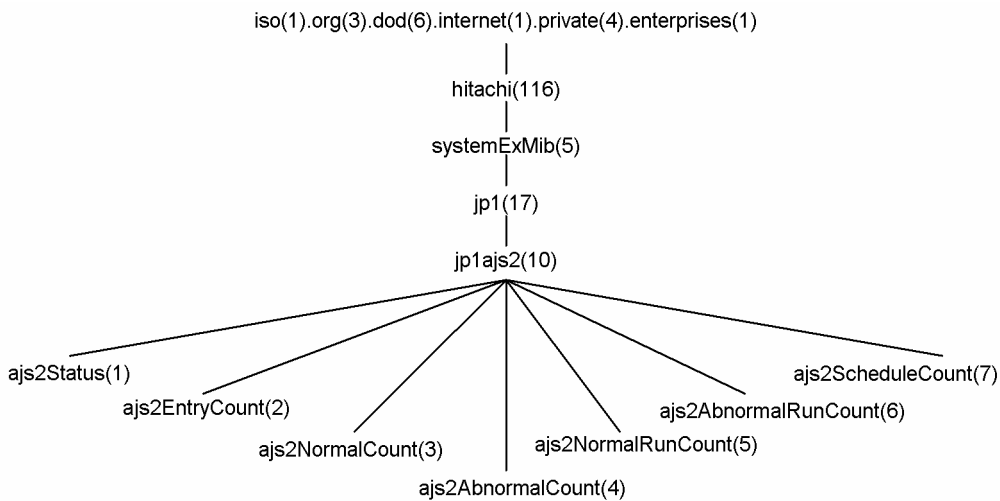

The following table lists MIB objects under jp1ajs2.

Table A–14: MIB objects under jp1ajs2

Object ID	Object name	Syntax	Description
1	ajs2Status	DisplayString	The status of JP1/AJS3 Unknown The status is unknown. Normal Executing normally. Minor Some abnormal-end jobs exist. Warning Some warning-end jobs exist. Critical Stopped. Restricted Restricted processing
2	ajs2EntryCount	Gauge	Number of registered jobnets
3	ajs2NormalCount	Gauge	Number of normal-end jobnets as of the current date
4	ajs2AbnormalCount	Gauge	Number of abnormal- or warning-end jobnets as of the current date
5	ajs2NormalRunCount	Gauge	Number of jobnets being executed
6	ajs2AbnormalRunCount	Gauge	Number of jobnets for which abnormal-end or warning is detected
7	ajs2ScheduleCount	Gauge	Number of jobnets scheduled as of the current date

B. Events Reported to HP NNM

Table B-1 and *Table B-2* cover the formats of the SNMP traps reported by JP1/AJS3 to HP NNM.

Table B-3 describes the format of an SNMP trap that is sent only when the root jobnet ended abnormally (specific trap associated with the Jp1ajs2_Err_Jobnet event).

Table B–1: SNMP trap format (1)

Enterprise ID	1.3.6.1.4.1.116.7.17.10			
General trap number	6			
Specific trap number	1~2			
Object ID	<i>Enterprise-ID.1.1.0</i>	<i>Enterprise-ID.1.2.0</i>	<i>Enterprise-ID.1.3.0</i>	<i>Enterprise-ID.1.4.0</i>
Value syntax	octetstring	octetstring	octetstring	octetstring
Value	Control name	Logical host name	JP1 symbol type	Scheduler service name

Table B–2: SNMP trap format (2)

Enterprise ID	1.3.6.1.4.1.116.7.17.10			
General trap number	6			
Specific trap number	1~2			
Object ID	<i>Enterprise-ID.1.5.0</i>	<i>Enterprise-ID.1.6.0</i>	<i>Enterprise-ID.1.7.0</i>	<i>Enterprise-ID.1.8.0</i>
Value syntax	octetstring	octetstring	octetstring	octetstring
Value	Symbol label name	Symbol type	Symbol status Unknown Normal Warning Minor Major Critical Restricted Testing Disabled	Additional information

Table B–3: SNMP trap format (3)

Enterprise ID	1.3.6.1.4.1.116.7.17.10				
General trap number	6				
Specific trap number	21				
Object ID	<i>Enterprise-ID.1.1.0</i>	<i>Enterprise-ID.1.2.0</i>	<i>Enterprise-ID.1.3.0</i>	<i>Enterprise-ID.1.4.0</i>	<i>Enterprise-ID.1.5.0</i>
Value syntax	octetstring	octetstring	octetstring	octetstring	octetstring
Value	Control name	Logical host name	Scheduler service name	Jobnet name	Symbol label name

For details on how to suppress sending SNMP traps for these events, see *A.2(4) Disabling SNMP trap transmission* (for Windows), or *A.3(2) Disabling SNMP trap transmission* (for UNIX) .

C. Commands Used When Linking with HP NNM

The following table lists the commands used when linking with HP NNM.

Table C–1: Commands used for HP NNM linkage

Function	Command name	Windows	UNIX	Required privileges	Supported products
Configures the registration files associated with the HP NNM	<code>ajsovsetup</code>	--	Y	Superuser	M and A
Removes the registration files associated with the HP NNM	<code>ajsovremove</code>	--	Y	Superuser	M and A
Deletes the JP1/AJS2 symbols from NNM	<code>ajsovsymrem</code>	--	Y	None	M and A
Issues SNMP traps	<code>ajsovtrap</code>	--	Y	None	M

Legend:

Y: Supported

--: Not supported

M: JP1/AJS3 - Manager

A: JP1/AJS3 - Agent

C.1 ajsovsetup

Format

```
ajsovsetup
```

Description

Configures the registration files for HP NNM.

The following files are configured:

- Application management file
- Field definition file
- Trap action definition file
- Trusted command definition file
- Extended MIB definition file (UNIX only)

Execution privileges

In Windows: Administrators privilege

In UNIX: Superuser privilege

Notes

- When linking with NNM on a Solaris host, do not execute the `ajsovsetup` command without first setting the setup language for the HP NNM in the `LANG` environment variable. For details on the values you can use for the `LANG` environment variable when linking with the HP NNM linkage, see the documentation for the HP NNM.

- When you execute the `ajsovsetup` command in UNIX, MIB definition information for JP1/AJS3 is added to or removed from the extended MIB definition file. For the new MIB definition information to take effect, you must restart the SNMP agent.

For details on restarting the SNMP agent, see the *Job Management Partner 1/Consolidated Management 2/Extensible SNMP Agent Description, Operator's Guide and Reference*.

Return values

0	Normal end
Other than 0	Abnormal end

Additional information

The `ajsovsetup` command takes no arguments. Any arguments you specify are ignored.

Example

To configure the registration files for HP NNM:

```
ajsovsetup
```

C.2 ajsovremove

Format

```
ajsovremove
```

Description

Removes the registration files associated with the HP NNM.

The following files are removed:

- Application management file
- Field definition file
- Trap action definition file
- Trusted command definition file
- Extended MIB definition file (UNIX only)

Execution privileges

In Windows: Administrators privilege

In UNIX: Superuser privilege

Notes

- Execute the `ajsovremove` command on the monitoring host (where NNM is installed) and the monitored host (where JP1/AJS3 is installed)
- When unlinking from NNM on a Solaris host, do not execute the `ajsovremove` command without first setting the setup language that you set when you executed `ajsovsetup` command for the HP NNM in the `LANG` environment variable.
- When you execute the `ajsovremove` command in UNIX, MIB definition information for JP1/AJS3 is removed from the extended MIB definition file. To invalidate this definition information, you must restart the SNMP agent. For details on restarting the SNMP agent, see the *Job Management Partner 1/Consolidated Management 2/Extensible SNMP Agent Description, Operator's Guide and Reference*.

Return values

0	Normal end
Other than 0	Abnormal end

Additional information

The `ajsovsetup` command takes no arguments. Any arguments you specify are ignored.

Example

To remove the registration files for HP NNM:

```
ajsovremove
```

C.3 ajsovsymrem

Format

```
ajsovsymrem
```

Description

Deletes the JP1/AJS3 symbols from NNM when linking with HP NNM.

Execution privileges

None

Notes

- The `ajsovsymrem` command requests deletion of the NNM objects that manage the symbols. The actual deletion of the symbols and objects takes place when you start NNM, or execute the **For All hosts** command in the NNM menu (by choosing **Administer, JP1/AJS2 Manager, Create symbol**, and then **For All hosts**).
- In UNIX, do not execute the `ajsovsymrem` command without first setting the setup language that you set when you executed the `ajsovsetup` command for the HP NNM in the `LANG` environment variable.

Return values

0	Normal end
Other than 0	Abnormal end

Additional information

The `ajsovsetup` command takes no arguments. Any arguments you specify are ignored.

Example

To delete the JP1/AJS3 symbols from NNM when linking with HP NNM:

```
ajsovsymrem
```

C.4 ajsovtrap (UNIX only)

Format

```
ajsovtrap  
[-F service-name]
```

```
[-m node-name]  
[-o company-ID]  
[-a agent-address]  
-n extended-trap-number  
object-ID  
value-syntax  
value
```

Description

Issues SNMP traps.

Under normal circumstances, this command is called from a scheduler service. However, when monitoring the status of JP1/AJS3 - Manager, a user can use this command to issue SNMP traps to the manager for HP NNM.

Execution privileges

None

Arguments

-F *service-name*

Specify the name of the scheduler service.

The name can be 1 to 30 bytes in length.

The SNMP trap destination is notified of the scheduler service name specified in this option.

When omitted, AJSROOT1 is used.

-m *node-name*

Specify the IP address or host name of the SNMP trap destination (the HP NNM manager).

The host name can be 1 to 255 bytes in length.

When omitted, SNMP traps are sent to all the nodes specified for the `trap-dest` parameter in the configuration definition file for the SNMP agent.

-o *company-ID*

Specify `sysObjectID`.

If you omit this option, the system assumes `.1.3.6.1.4.1.116.7.17.10`.

-a *agent-address*

Specify the IP address or host name of the instance of JP1/AJS3 - Manager that serves as the SNMP trap source (the HP NNM agent).

The host name can be 1 to 255 bytes in length.

When omitted, the system assumes the name of the host from which the command is executed.

-n *extended-trap-number*

Specify an integer representing the extended trap number.

You can specify 1 or 2.

object-ID

Specify the object ID, without the company ID component.

For example, if you specify 2 as the object ID, the object ID set for the `snmptrap` command is `.1.3.6.1.4.1.116.7.17.10.2.0`.

value-syntax

Select the value syntax from among the following eight items:

- `integer`

- `octetstring`
- `objectidentifier`
- `ipaddress`
- `counter`
- `gauge`
- `timeticks`
- `opaque`

value

Specify a value that conforms to the *value syntax*.

For details, see the documentation for HP NNM.

Notes

- This command is only available for UNIX. You cannot execute this command in Windows.
- SNMP traps are implemented by UDP (User Datagram Protocol); therefore, the reliability of SNMP trap notification to the HP NNM manager depends on the UDP protocol.

Example

The following command uses an SNMP trap to notify the HP NNM manager (`Manager`) that the status of JP1/AJS3 - Manager is unknown.

```
ajsovtrap -m Manager -n 2 1 octetstring Unknown
```

D. Version Revisions

For details on the version revisions, see *B. Version Revisions* in the manual *JP1/Automatic Job Management System 3 Overview*.

E. Reference Material for This Manual

For details on reference information that would be helpful in reading this manual, see *C. Reference Material for This Manual* in the manual *JP1/Automatic Job Management System 3 Overview*.

F. Glossary

For the glossary, see *D. Glossary* in the manual *JP1/Automatic Job Management System 3 Overview*.

Index

A

AfterReceiveMail 45
agent host setup procedure
 for linking mail systems 57
ajsovremove 194
ajsovsetup 193
ajsovsymrem 195
ajsovtrap (UNIX only) 195
automatic distribution 157
automatic distribution using JP1/Software Distribution 153

C

character set conversion 68
ConnectTimeout 30
customizing community name for authentication
 for UNIX host 184
 for Windows host 178
customizing send source host name
 for UNIX host 183
 for Windows host 177
customizing SNMP trap
 for UNIX host 183
 for Windows host 177
custom job 80
 adding 79
 cautionary notes 86
custom PC job 81
custom Unix job 81

D

decoding MIME 69
default custom job 80
Defining email sending job 75
defining ERP linkage jobs 96
defining SNMP service startup timing 175
disabling SNMP trap transmission
 for UNIX host 182
 for Windows host 177

E

email
 example list file 73

format of list files 72
format of list of attached files 75
overview of email reception 20
overview of email sending 25
setting up mail system linkage (when not using Outlook) 29
setting up mail system linkage (when using Outlook) 38
email reception
 overview (in UNIX) 20
 overview (in Windows) 20
email reception monitoring job
 defining 70
 environment setting parameters 60
 judgment method 70
email sending
 overview (in UNIX) 26
 overview (in Windows) 25
EmbeddedMailSender 30
EmbeddedMailTimeout 31
error email file 25
events reported to HP NNM 192
Exchange Server 36
ExecMode 43
ExecMode (mail linkage) 63
executing script files 112

F

file for listing received email 25
file for storing email 25
file for storing passing information 24
file for storing unmatched email 25
files used by the mail filter application 67
format of email to be sent 75
format of received email 71

G

gif file for icons 84

H

HP NNM 172

I

ImmediateSendRecv 46

internal email file 24

J

JP1/AJS3 for Enterprise Applications 93

JP1/IM 138

L

linking ERP systems 92

overview 93

linking hp NonStop Server 103

linking JP1/DH - AJE 162

linking JP1/DH - AJE

overview 163

linking JP1/FTP 87

Linking JP1/PFM 166

linking JP1/Script 108

linking mail systems 19

linking mainframes 98

linking mainframes Using JP1/OJE 97

LogSize_EmbeddedMail 32

M

mail delivery function 64

MailFileDir 61

MailFileName 61

mail filtering application 67

mail system linkage function

starting and ending (for UNIX host) 64

mail systems 20

mail systems that support linkage (when not using Outlook) 28

mail systems that support linkage (when using Outlook) 36

MIB objects 190

monitoring jobnets using HP NNM 172

monitoring jobnets using JP1/IM and JP1/IM2 113

monitoring using JP1 events 114

N

NextAddress 45

NotMatchMailDir 62

O

overview

linking JP1/DH - AJE 163

P

package 159

ProfileName1 44

ProfileName2 44

ProfileName3 44

ProfileName4 44

R

ReceivedMailFormat 62

ReceiveIntervalC 46, 60

receiving email

overview (in UNIX) 24

overview (in Windows) 21

reception list file 73

RecvTimeout 31

registering custom PC jobs or custom Unix jobs 84

registering default custom jobs 83

registering VOS3 user information with JP1/AJS3 101

RetryCount 31

RetryInterval 31

S

SAP 93

SAP BW system 93, 94

SAP system 94

SendCutOffExcessiveData 32, 47

setting up mail delivery function 64

setup

for linking HP NNM 174, 181

for linking hp NonStop Server 105

for linking JP1/DH - AJE 164

for linking JP1/FTP 89

for linking JP1/IM 121

for linking JP1/IM2 131

for linking JP1/IM - Console 121

for linking JP1/Script 110

for linking JP1/Software Distribution 155

SMTP/POP3 36

SNMP trap format 192

SNMP traps 186

starting up and ending mail system linkage function (when using Outlook) 49

T

transferring files using JP1/FTP 91

U

UserName 61

W

WrapTextWithOutlookOption 47

 **Hitachi, Ltd.**

6-6, Marunouchi 1-chome, Chiyoda-ku, Tokyo, 100-8280 Japan
