

JP1 Version 12

**JP1/Performance Management - Agent Option for
Enterprise Applications Description, User's Guide
and Reference**

3021-3-D88(E)

Notices

■ Relevant program products

JP1/Performance Management - Manager (for Windows Server 2012, Windows Server 2016):

P-2A2C-AACL JP1/Performance Management - Manager version 12-00

The above product includes the following:

P-CC2A2C-5ACL JP1/Performance Management - Manager version 12-00

P-CC2A2C-5RCL JP1/Performance Management - Web Console version 12-00

JP1/Performance Management - Manager (for CentOS 6 (x64), CentOS 7, Linux 6 (x64), Linux 7, Oracle Linux 6 (x64), Oracle Linux 7, SUSE Linux 12):

P-812C-AACL JP1/Performance Management - Manager version 12-00

The above product includes the following:

P-CC812C-5ACL JP1/Performance Management - Manager version 12-00

P-CC812C-5RCL JP1/Performance Management - Web Console version 12-00

JP1/Performance Management - Agent Option for Enterprise Applications (for Windows Server 2012, Windows Server 2016):

P-2A2C-AFCL JP1/Performance Management - Agent Option for Enterprise Applications version 12-00

The above product includes the following:

P-CC2A2C-FFCL JP1/Performance Management - Agent Option for Enterprise Applications version 12-00

P-CC2A2C-AJCL JP1/Performance Management - Base version 12-00

JP1/Performance Management - Agent Option for Enterprise Applications (for Linux 6 (x64), Linux 7, Oracle Linux 6 (x64), Oracle Linux 7, SUSE Linux 12):

P-812C-AFCL JP1/Performance Management - Agent Option for Enterprise Applications version 12-00

The above product includes the following:

P-CC812C-FFCL JP1/Performance Management - Agent Option for Enterprise Applications version 12-00

P-CC812C-AJCL JP1/Performance Management - Base version 12-00

These products include the parts developed under licenses from other companies.

■ Trademarks

HITACHI, JP1 are either trademarks or registered trademarks of Hitachi, Ltd. in Japan and other countries.

AMD, AMD Opteron, and combinations thereof, are trademarks of Advanced Micro Devices, Inc.

IBM is trademark of International Business Machines Corporation, registered in many jurisdictions worldwide.

IBM, DB2 are trademarks of International Business Machines Corporation, registered in many jurisdictions worldwide.

IBM, DB2 Universal Database are trademarks of International Business Machines Corporation, registered in many jurisdictions worldwide.

IBM, Lotus are trademarks of International Business Machines Corporation, registered in many jurisdictions worldwide.

IBM, WebSphere are trademarks of International Business Machines Corporation, registered in many jurisdictions worldwide.

Microsoft is either a registered trademark or a trademark of Microsoft Corporation in the United States and/or other countries.

Hyper-V is either a registered trademark or a trademark of Microsoft Corporation in the United States and/or other countries.

Oracle and Java are registered trademarks of Oracle and/or its affiliates.

Red Hat is a trademark or a registered trademark of Red Hat Inc. in the United States and other countries.

SAP and other SAP products and services mentioned herein as well as their respective logos are trademarks or registered trademarks of SAP SE in Germany and other countries.

SAP and ABAP and other SAP products and services mentioned herein as well as their respective logos are trademarks or registered trademarks of SAP SE in Germany and other countries.

SAP and R/3 and other SAP products and services mentioned herein as well as their respective logos are trademarks or registered trademarks of SAP SE in Germany and other countries.

SAP and SAP NetWeaver and other SAP products and services mentioned herein as well as their respective logos are trademarks or registered trademarks of SAP SE in Germany and other countries.

All SPARC trademarks are used under license and are trademarks or registered trademarks of SPARC International, Inc., in the United States and other countries. Products bearing SPARC trademarks are based upon an architecture developed by Sun Microsystems, Inc.

UNIX is a registered trademark of The Open Group in the United States and other countries.

Visual C++ is either a registered trademark or a trademark of Microsoft Corporation in the United States and/or other countries.

Windows is either a registered trademark or a trademark of Microsoft Corporation in the United States and/or other countries.

Windows Server is either a registered trademark or a trademark of Microsoft Corporation in the United States and/or other countries.

Other company and product names mentioned in this document may be the trademarks of their respective owners.

Other product and company names mentioned in this document may be the trademarks of their respective owners.

Throughout this document Hitachi has attempted to distinguish trademarks from descriptive terms by writing the name with the capitalization used by the manufacturer, or by writing the name with initial capital letters. Hitachi cannot attest to the accuracy of this information. Use of a trademark in this document should not be regarded as affecting the validity of the trademark.

■ Restrictions

Information in this document is subject to change without notice and does not represent a commitment on the part of Hitachi. The software described in this manual is furnished according to a license agreement with Hitachi. The license agreement contains all of the terms and conditions governing your use of the software and documentation, including all warranty rights, limitations of liability, and disclaimers of warranty.

Material contained in this document may describe Hitachi products not available or features not available in your country.

No part of this material may be reproduced in any form or by any means without permission in writing from the publisher.

■ Microsoft product name abbreviations

This manual uses the following abbreviations for Microsoft product names.

Abbreviation		Full name or meaning
Internet Explorer		Microsoft Internet Explorer
		Windows(R) Internet Explorer(R)
Win32		Win32(R)
Windows Server 2012	Windows Server 2012	Microsoft ^(R) Windows Server ^(R) 2012 Datacenter
		Microsoft ^(R) Windows Server ^(R) 2012 Standard
	Windows Server 2012 R2	Microsoft ^(R) Windows Server ^(R) 2012 R2 Datacenter
		Microsoft ^(R) Windows Server ^(R) 2012 R2 Standard
Windows Server 2016		Microsoft(R) Windows Server(R) 2016 Datacenter
		Microsoft(R) Windows Server(R) 2016 Standard

Windows Server 2012 and Windows Server 2016 may be referred to collectively as *Windows*.

■ Issued

Jan. 2019: 3021-3-D88(E)

■ Copyright

All Rights Reserved. Copyright (C) 2019, Hitachi, Ltd.

Summary of amendments

The following table lists changes in this manual (3021-3-D88(E)) and product changes related to this manual.

Changes	Changes
The following OS is now supported: <ul style="list-style-type: none">• Windows Server 2016	--
The following OS is no longer supported: <ul style="list-style-type: none">• Windows Server 2008 R2	--
The remote monitoring of SAP systems is now possible.	1.1.8, 3.1.1, 3.1.2, 3.1.5, 3.1.6, 3.2.1, 3.2.2, 3.2.5, 3.2.6, 3.5, 3.6.3, 4.1, 4.3.1, 4.4.1, 5.3.1, 5.3.2, 5.4.3, 6.3.1, 6.3.2, 6.4.3, 8, 13.2.7, E.2

In addition to the above changes, minor editorial corrections were made.

Preface

This manual describes the functionality and records of JP1/Performance Management - Agent Option for Enterprise Applications.

■ Intended readers

This manual is intended for the following readers:

- Users who wish to learn about the features provided by JP1/Performance Management - Agent Option for Enterprise Applications and about the records it collects.
- Users who wish to design and run systems that use JP1/Performance Management to collect SAP R/3 performance data.

It is assumed that the reader is familiar with SAP R/3.

For details about how to configure and use systems that utilize JP1/Performance Management, we recommend that you also use the following manuals:

- *Performance Management: Getting Started (Operation and Performance Management)*
- *JP1/Performance Management Planning and Configuration Guide*
- *JP1/Performance Management User's Guide*
- *JP1/Performance Management Reference*

■ Organization of this manual

This manual is organized into the chapters listed below. The manual applies to all operating systems (OSs). Any information unique to a particular OS is so indicated.

Chapter 1: Overview of PFM - Agent for Enterprise Applications

This chapter provides an overview of PFM - Agent for Enterprise Applications, including a description of what you can do with the program.

Chapter 2: Performance Monitoring

This chapter describes performance monitoring using PFM - Agent for Enterprise Applications.

Chapter 3: Installation and Setup

This chapter explains how to install and set up PFM - Agent for Enterprise Applications.

Chapter 4: Operation in a Cluster System

This chapter describes the installation and setup of PFM - Agent for Enterprise Applications in a cluster system and the general operating procedures when PFM - Agent for Enterprise Applications is operated in a cluster system.

Chapter 5: Extracting System Log Information

This chapter explains how to use PFM - Agent for Enterprise Applications to extract system log information.

Chapter 6: Extracting CCMS Alert Information

This chapter explains how to use PFM - Agent for Enterprise Applications to extract CCMS alert information.

Chapter 7: Collecting Monitor Information

This chapter explains how to use PFM - Agent for Enterprise Applications to collect an SAP system's monitor information.

Chapter 8: Notes on Operating

This chapter describes the notes about the operations of PFM - Agent for Enterprise Applications.

Chapter 9: Monitoring Template

This chapter describes the monitoring template for PFM - Agent for Enterprise Applications.

Chapter 10: Records

This chapter describes the records for PFM - Agent for Enterprise Applications.

Chapter 11: Commands

This chapter describes the commands provided by PFM - Agent for Enterprise Applications.

Chapter 12: Messages

This chapter describes the format of the PFM - Agent for Enterprise Applications messages, lists the locations to which messages are output, shows which messages are output to syslog and the Windows event log, and describes the messages in detail.

Chapter 13: Error Handling Procedures

This chapter describes the actions to be taken for errors that might occur during operation, focusing on PFM - Agent.

■ Conventions: Diagrams

This manual uses the following conventions in diagrams:

● Computer



● Server



● Input/output operation



● Program

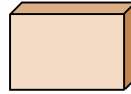

● File

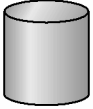

● Database

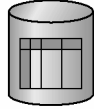

● Network

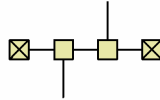

● Failure



● Flow of data

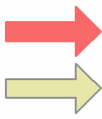

● Flow of processing



● Other flow

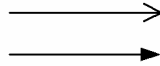

■ Conventions: Fonts and symbols

Font and symbol conventions are classified as:

- General font conventions
- Conventions in syntax explanations

These conventions are described below.

General font conventions

The following table lists the general font conventions:

Font	Convention
Bold	<p>Bold type indicates text on a window, other than the window title. Such text includes menus, menu options, buttons, radio box options, or explanatory labels. For example, bold is used in sentences such as the following:</p> <ul style="list-style-type: none"> • From the File menu, choose Open. • Click the Cancel button. • In the Enter name entry box, type your name.
<i>Italics</i>	<p>Italics are used to indicate a placeholder for some actual text provided by the user or system. Italics are also used for emphasis. For example:</p> <ul style="list-style-type: none"> • Write the command as follows: <code>copy source-file target-file</code> • Do <i>not</i> delete the configuration file.
Code font	<p>A code font indicates text that the user enters without change, or text (such as messages) output by the system. For example:</p> <ul style="list-style-type: none"> • At the prompt, enter <code>dir</code>. • Use the <code>send</code> command to send mail. • The following message is displayed: <code>The password is incorrect.</code>

Examples of coding and messages appear as follows (although there may be some exceptions, such as when coding is included in a diagram):

```
MakeDatabase
...
StoreDatabase temp DB32
```

In examples of coding, an ellipsis (...) indicates that one or more lines of coding are not shown for purposes of brevity.

Conventions in syntax explanations

Syntax definitions appear as follows:

```
StoreDatabase [temp|perm] (database-name ...)
```

The following table lists the conventions used in syntax explanations:

Example font or symbol	Convention
StoreDatabase	Code-font characters must be entered exactly as shown.
<i>database-name</i>	This font style marks a placeholder that indicates where appropriate characters are to be entered in an actual command.
SD	Bold code-font characters indicate the abbreviation for a command.
<u>perm</u>	Underlined characters indicate the default value.
[]	Square brackets enclose an item or set of items whose specification is optional.
{ }	One of the items enclosed in curly brackets and separated by a vertical bar must be specified.
	Only one of the options separated by a vertical bar can be specified at the same time.
...	An ellipsis (...) indicates that the item or items enclosed in () or [] immediately preceding the ellipsis may be specified as many times as necessary.
()	Parentheses indicate the range of items to which the vertical bar () or ellipsis (...) is applicable.

Conventions for mathematical expressions

This manual uses the following symbols in mathematical expressions:

Symbol	Meaning
x	Multiplication sign
/	Division sign

■ Conventions: Version numbers

The version numbers of Hitachi program products are usually written as two sets of two digits each, separated by a hyphen. For example:

- Version 1.00 (or 1.0) is written as 01-00.
- Version 2.05 is written as 02-05.

- Version 2.50 (or 2.5) is written as 02-50.
- Version 12.25 is written as 12-25.

The version number might be shown on the spine of a manual as *Ver. 2.00*, but the same version number would be written in the program as *02-00*.

Contents

Notices	2
Summary of amendments	5
Preface	6

Part 1: Overview

1	Overview of PFM - Agent for Enterprise Applications	18
1.1	Features of PFM - Agent for Enterprise Applications	19
1.1.1	Collect SAP system performance data	19
1.1.2	Collect performance data according to its characteristics	20
1.1.3	Save performance data	20
1.1.4	Report problems in SAP system operations	20
1.1.5	Easily define alarms and reports	21
1.1.6	Extract the SAP system's log information and CCMS alert information	21
1.1.7	Collect the SAP system's monitor information	21
1.1.8	Remotely monitor the SAP system	22
2	Performance Monitoring	23
2.1	About performance monitoring	24
2.1.1	Purposes of performance monitoring	24
2.1.2	Selecting a baseline	24
2.1.3	Examples of performance monitoring	25

Part 2: Setup and Operation

3	Installation and Setup	29
3.1	Installation and setup in Windows	30
3.1.1	What to check before installing and setting up PFM - Agent for Enterprise Applications in Windows	30
3.1.2	Flow of tasks for installation and setup in Windows	34
3.1.3	Installation procedure in Windows	35
3.1.4	Library application procedure	37
3.1.5	Setup procedure in Windows	37
3.1.6	Notes about installation and setup in Windows	45
3.2	Installation and setup in Linux	49
3.2.1	What to check before installing and setting up PFM - Agent for Enterprise Applications in Linux	49
3.2.2	Flow of tasks for installation and setup in Linux	53
3.2.3	Installation procedure in Linux	55

3.2.4	Library application procedure	56
3.2.5	Setup procedure in Linux	56
3.2.6	Notes about installation and setup in Linux	65
3.3	Uninstallation and unsetup in Windows	68
3.3.1	Notes before uninstallation and unsetup in Windows	68
3.3.2	Unsetup procedure in Windows	69
3.3.3	Uninstallation procedure in Windows	70
3.4	Uninstallation and unsetup in Linux	71
3.4.1	Notes before uninstallation and unsetup in Linux	71
3.4.2	Unsetup procedure in Linux	71
3.4.3	Uninstallation procedure in Linux	72
3.5	Changing the PFM - Agent for Enterprise Applications system configuration	74
3.6	Changing the PFM - Agent for Enterprise Applications operation method	75
3.6.1	Changing the performance data storage location	75
3.6.2	Updating the Store version to 2.0	80
3.6.3	Settings for updating an instance environment	82
3.7	Backing up and restoring PFM - Agent for Enterprise Applications	85
3.7.1	Backup	85
3.7.2	Restoration	86
3.8	Settings for using a Web browser to reference manuals	88
3.8.1	Setup procedure for referencing manuals	88
3.8.2	How to view manuals	89
4	Operation in a Cluster System	90
4.1	Configuration of PFM - Agent for Enterprise Applications in a cluster system	91
4.2	Processing at failover	93
4.2.1	Failover when an error occurs on a PFM - Agent host	93
4.2.2	Effects of PFM - Manager failure and the action to be taken	94
4.3	Installation and setup in a Windows cluster system	96
4.3.1	SAP NetWeaver 7.0 or later (Windows)	96
4.4	Installation and setup in a Linux cluster system	108
4.4.1	SAP NetWeaver 7.0 or later (Linux)	108
4.5	Uninstallation and unsetup in a Windows cluster system	120
4.5.1	SAP NetWeaver 7.0 or later (Windows)	120
4.6	Uninstallation and unsetup in a Linux cluster system	122
4.6.1	SAP NetWeaver 7.0 or later (Linux)	122
4.7	Changing the system configuration of PFM - Agent for Enterprise Applications in a cluster system	124
4.8	Changing the PFM - Agent for Enterprise Applications operation method in a cluster system	125
4.8.1	Changing the performance data storage location in a cluster system	125
4.8.2	Updating the Store version to 2.0 in a cluster system	125
4.8.3	Settings for updating an instance environment in a cluster system	125
4.9	Backing up and restoring PFM - Agent for Enterprise Applications in a cluster system	126

4.10 Notes 127

5 Extracting System Log Information 128

- 5.1 Overview of the system log information extraction function 129
- 5.2 Extracting system log information 132
 - 5.2.1 Setup 133
 - 5.2.2 Output example 133
- 5.3 Environment parameters file 135
 - 5.3.1 Setup procedure 135
 - 5.3.2 Settings 136
- 5.4 Using a command to extract system log information 142
 - 5.4.1 Before executing the command 142
 - 5.4.2 Using the command to extract system log information 142
 - 5.4.3 Environment parameters file for extracting system log information by command execution 143

6 Extracting CCMS Alert Information 151

- 6.1 Overview of the CCMS alert information extraction function 152
- 6.2 Extracting CCMS alert information 154
 - 6.2.1 Setup 155
 - 6.2.2 Output example 155
- 6.3 Environment parameters file 157
 - 6.3.1 Setup procedure 157
 - 6.3.2 Settings 158
- 6.4 Using a command to extract CCMS alert information 164
 - 6.4.1 Before executing the command 164
 - 6.4.2 Using the command to extract CCMS alert information 164
 - 6.4.3 Environment parameters file for extracting CCMS alert information by command execution 165

7 Collecting Monitor Information 173

- 7.1 Overview of collecting monitor information 174
- 7.2 Settings for collecting monitor information 175
 - 7.2.1 Setting a monitor set name and a monitor name 175
 - 7.2.2 Settings for performance data collection 176

8 Notes on Operating 177

- 8.1 Notes on the collection base time 178
- 8.2 Notes on the SAP system time zone 179
- 8.3 Notes on system operation 180

Part 3: Reference

9 Monitoring Template 181

- Overview of the monitoring template 182

Format of alarm explanations	183
List of alarms	184
Buffer - CUA	186
Buffer - FieldDescri	187
Buffer - GenericKey	188
Buffer - InitialReco	189
Buffer - Program	190
Buffer - Screen	191
Buffer - ShortNameTA	192
Buffer - SingleRecor	193
Buffer - TableDefini	194
Dialog ResponseTime	195
Extended Memory	196
Heap Memory	197
Paging Area	198
Roll Area	199
SystemWideQueue	200
ServerSpecificQueue	201
Utilization % (alarm for monitoring the average usage of background work processes)	202
QueueLength %	203
Utilization % (alarm for monitoring the average usage of dialog processes)	204
Format of report explanations	205
Organization of report folders	206
List of reports	208
Dialog ResponseTime	210
Dialog ResponseTime Status	211
Dialog ResponseTime Trend (hourly historical report)	212
Dialog ResponseTime Trend (daily historical report)	213
Dialog ResponseTime Trend (Multi-Agent)	214
Dialog Utilization %	215
Process Detail	216
Process Overview Status	217
SAP Buffer Detail (CUA)	218
SAP Buffer Detail (FieldDescription)	219
SAP Buffer Detail (GenericKey)	220
SAP Buffer Detail (InitialRecords)	221
SAP Buffer Detail (Program)	222
SAP Buffer Detail (Screen)	223
SAP Buffer Detail (ShortNameTAB)	224
SAP Buffer Detail (SingleRecord)	225
SAP Buffer Detail (TableDefinition)	226
SAP Buffer Hitratio	227
SAP Buffer Hitratio Status	228
SAP Buffer Hitratio Trend (hourly historical report)	230
SAP Buffer Hitratio Trend (daily historical report)	231
SAP Memory Detail	232
SAP Memory Used	233

- SAP Memory Used Status 234
- SAP Memory Used Trend (hourly historical report) 235
- SAP Memory Used Trend (daily historical report) 236
- UsersLoggedIn Trend (hourly historical report) 237
- UsersLoggedIn Trend (daily historical report) 238
- UsersLoggedIn Trend (Multi-Agent) 239
- Background Processing SystemWideQueue 240
- Background Service ServerSpecificQueue 241
- Background Service Utilization % 242

10 **Records 243**

- Data model 244
- Format of record explanations 245
- List of ODBC key fields 247
- Summary rules 248
- List of data types 251
- Field values 252
- Fields added only when data is stored in the Store database 254
- Notes about records 255
- List of records 257
- Background Processing (PI_BTCP) 259
- Background Service (PI_BTC) 261
- CCMS Alert Monitor Command (PD_ALMX) 263
- Dialog Service (PI_DIA) 265
- Enqueue Service (PI_ENQ) 268
- SAP Buffer Summary (PI_BUFF) 270
- SAP Instance Summary (PD_SRV) 275
- SAP Memory Summary (PI_MEM) 277
- Spool Service (PI_SPO) 280
- System Log Monitor Command (PD_SLMX) 282
- Update1 Service (PI_UPD1) 284
- Update2 Service (PI_UPD2) 286
- User defined Monitor (Perf.) (PI_UMP) 288
- Work Process Summary (PD) 290
- WorkLoad Summary Interval (PI) 293

11 **Commands 297**

- Format of command explanations 298
- List of commands 300
- jr3alget 301
- jr3slget 308

12 **Messages 314**

- 12.1 Message format 315
- 12.1.1 Format of output messages 315
- 12.1.2 Format of message explanations 316

- 12.2 Message output destinations 317
- 12.3 Messages output to syslog and Windows event log 321
- 12.4 Messages 323

Part 4: Troubleshooting

13 Error Handling Procedures 356

- 13.1 Error handling procedures 357
- 13.2 Troubleshooting 358
 - 13.2.1 Troubleshooting related to setup and service startup 358
 - 13.2.2 Troubleshooting related to command execution 362
 - 13.2.3 Troubleshooting related to report definitions 363
 - 13.2.4 Troubleshooting related to alarm definitions 363
 - 13.2.5 Troubleshooting related to collection and management of performance data 364
 - 13.2.6 Troubleshooting related to the log monitoring program 365
 - 13.2.7 Troubleshooting related to the remote monitoring function 367
 - 13.2.8 Troubleshooting related to other problems 368
- 13.3 Log information to be collected during troubleshooting 369
 - 13.3.1 Type of log information to be collected during troubleshooting 369
 - 13.3.2 Lists of log files and directories to be collected during troubleshooting 370
- 13.4 Data to be collected during troubleshooting 372
 - 13.4.1 Data to be collected during troubleshooting in a Windows environment 372
 - 13.4.2 Data to be collected during troubleshooting in a Linux environment 377
- 13.5 How to collect data during troubleshooting 383
 - 13.5.1 How to collect data during troubleshooting in a Windows environment 383
 - 13.5.2 How to collect data during troubleshooting in a Linux environment 386
- 13.6 Detecting problems within Performance Management 389
- 13.7 Performance Management system error recovery 390

Appendixes 391

- A System Estimates Before Configuration 392
 - A.1 Memory requirements 392
 - A.2 Disk space requirements 392
 - A.3 Disk space requirements for cluster use 392
- B Kernel Parameters 393
- C List of Identifiers 394
- D List of Processes 395
- E List of Port Numbers 397
 - E.1 Port numbers of Performance Management 397
 - E.2 Firewall passage directions 397
- F Properties of PFM - Agent for Enterprise Applications 399
 - F.1 List of Agent Store service properties 399

F.2	List of Agent Collector service properties	402
G	Lists of Directories and Files	411
G.1	List of folders and files (Windows)	411
G.2	List of directories and files (Linux)	416
H	Migration Steps and Notes on Migration	421
H.1	Upgrade installation	421
H.2	Extracting the system log information and CCMS Alert Information	421
I	Version Compatibility	422
J	Outputting Action Log Data	423
J.1	Types of events output to the action log	423
J.2	Format for saving the action log files	423
J.3	Format of output action log data	424
J.4	Settings for outputting action log data	429
K	Working with JP1/SLM	432
L	Version Changes	433
L.1	Changes in version 12-00	433
L.2	Changes in version 11-00	433
L.3	Changes in version 10-51	433
L.4	Changes in version 10-00	433
L.5	Changes in version 09-00	434
M	Reference Material for this Manual	435
M.1	Related publications	435
M.2	Conventions: Abbreviations	435
M.3	Acronyms	437
M.4	Format of product names, service IDs, and service keys in this manual	437
M.5	Performance Management installation folders	438
M.6	Conventions: KB, MB, GB and TB	438
N	Glossary	439

Index 442

1

Overview of PFM - Agent for Enterprise Applications

This chapter provides an overview of PFM - Agent for Enterprise Applications.

1.1 Features of PFM - Agent for Enterprise Applications

PFM - Agent for Enterprise Applications is a program that collects and manages performance data, enabling you to monitor the performance of an SAP system.

PFM - Agent for Enterprise Applications has the following features:

- Ability to analyze the operating status of an SAP system
PFM - Agent for Enterprise Applications enables you to easily analyze the operating status of an SAP system by collecting and summarizing performance data (such as statistical information about response time and work process usage) obtained from the SAP system being monitored, and graphically displaying any trends or changes.
- Ability to detect the operational problems of an SAP system and quickly provide the information needed to identify the cause of a problem
In the event of a problem in performance, such as a delay in the response time on the SAP system being monitored, PFM - Agent for Enterprise Applications helps the user become aware of the problem at an early stage by sending a notification, such as an email, to the user. PFM - Agent for Enterprise Applications also provides a graphic display of information needed to identify the cause of a problem.

You must have PFM - Manager and PFM - View in order to use PFM - Agent for Enterprise Applications.

The following sub-sections describe PFM - Agent for Enterprise Applications.

1.1.1 Collect SAP system performance data

PFM - Agent for Enterprise Applications enables you to collect performance data, such as statistical information on the current SAP system's background service on the host being monitored.

With PFM - Agent for Enterprise Applications, you use the collected performance data as follows:

- Displaying the SAP system's operating status
By using PFM - Web Console, you can process and display performance data in a graphical format called a *report*. A report facilitates analysis of the SAP system's operating status.
There are two types of reports:
 - *Real-time reports*
A real-time report indicates the current status of an SAP system being monitored. It is used primarily to check the current status of the system and to detect problems in the system. To display real-time reports, PFM - Agent for Enterprise Applications uses current performance data that has just been collected.
 - *Historical reports*
A historical report indicates the status of a monitored SAP system from a time in the past to the present. Its principal use is for analyzing trends in the system. To display a historical report, the system uses performance data that has been stored in a database for PFM - Agent for Enterprise Applications.
- Using the collected data as criteria for determining whether a problem has occurred
You can set PFM - Agent for Enterprise Applications to take some action (such as notifying the user) if collected performance data indicates an abnormality.

1.1.2 Collect performance data according to its characteristics

PFM - Agent for Enterprise Applications collects performance data in *records*. Each record consists of smaller units called *fields*. Records and fields are referred to collectively as the *data model*.

Records are classified into two types according to their characteristics. The record types that are used to collect performance data are predefined in PFM - Agent for Enterprise Applications. The user simply uses PFM - Web Console to specify the performance data records to be collected.

PFM - Agent for Enterprise Applications supports the following two record types:

- Product Interval record type (referred to hereafter as the *PI record type*)
For records of the PI record type, the system collects performance data for a specified interval, such as the number of processes in one minute. You can use these records to analyze changes or trends in the system status over time.
- Product Detail record type (referred to hereafter as the *PD record type*)
For records of the PD record type, the system collects performance data that indicates the system status at a specific point in time, such as detailed information about the currently active processes. You can use these records to obtain the system status at a particular time.

For more information about record types, see [Chapter 10. Records](#).

1.1.3 Save performance data

By storing collected performance data into a special database, you can save the performance data up to the current date, and can analyze trends (from the past to the current date) in the SAP system's operating states. This special database is called the *Store database* of PFM - Agent for Enterprise Applications. The historical reports are used for analyzing trends.

Use PFM - Web Console to select the performance data records to be stored in the Store database. For details about how to select records with PFM - Web Console, see the chapter that describes management of operation monitoring data in the *JP1/Performance Management User's Guide*.

1.1.4 Report problems in SAP system operations

You use performance data collected by PFM - Agent for Enterprise Applications not only for displaying SAP system performance as reports but also for warning the user in the event of a problem or error during SAP system operation.

Suppose that you want to be notified by email whenever a minute-by-minute dialog task's response time exceeds 3,000 milliseconds. To do this, for minute-by-minute dialog tasks, set a response time exceeding 3,000 milliseconds as the abnormal condition threshold, and instruct the system to send you an email if this threshold is reached. What the system does when the threshold is reached is called an *action*. The following types of actions are available:

- Sending an email
- Executing a command
- Issuing an SNMP trap
- Issuing a JP1 event

The definition of a threshold or action is called an *alarm*. A table of the defined alarms is called an *alarm table*. Once an alarm table is defined, it is associated with PFM - Agent for Enterprise Applications. Associating an alarm table with

PFM - Agent for Enterprise Applications is called *binding*. Once an alarm table has been bound to PFM - Agent for Enterprise Applications, whenever the performance data collected by PFM - Agent for Enterprise Applications reaches the threshold defined as an alarm, the event is reported to the user.

By defining alarms and actions, you can detect problems in the SAP system operation at an early stage and take appropriate actions.

For details about how to set alarms and actions, see the chapter that describes operation monitoring by alarms in the *JP1/Performance Management User's Guide*.

1.1.5 Easily define alarms and reports

PFM - Agent for Enterprise Applications provides a *monitoring template*, in which necessary information for standard reports and alarms is predefined. This monitoring template facilitates setup for monitoring the SAP system's operating status, because it does not require you to make complicated definitions. You can also customize the monitoring template as appropriate to your environment.

For details about how to use the monitoring template, see the chapter that describes report creation for operation analysis or the chapter that describes operation monitoring by alarms in the *JP1/Performance Management User's Guide*. For details about the monitoring template, see [Chapter 9. Monitoring Template](#).

1.1.6 Extract the SAP system's log information and CCMS alert information

PFM - Agent for Enterprise Applications can output periodically to text files the following information about the SAP system:

- *System log information*
This is a log (system log) for recording the events and errors that occur in the SAP system. A system log is created for each application server.
- *CCMS alert information*
These are the warnings (alert information) that occur in the warning monitor of the computer center management system (CCMS) in the SAP system.

You can use a log file trapping function, such as the one provided by JP1/Base, to convert the information in a text file to JP1 events. By monitoring these JP1 events from JP1/IM, you can monitor the SAP system's operating status from JP1/IM.

For details about how to extract system log information for an SAP system, see [Chapter 5. Extracting System Log Information](#). For details about how to extract CCMS alert information, see [Chapter 6. Extracting CCMS Alert Information](#).

1.1.7 Collect the SAP system's monitor information

PFM - Agent for Enterprise Applications can collect the SAP system's monitor information based on user definitions. This makes it possible to collect performance information that is not provided as records by PFM - Agent for Enterprise Applications. Note that PFM - Agent for Enterprise Applications can collect only the monitor information for the SAP system that has the performance attribute.

For details about collecting the SAP system's monitor information, see *Chapter 7. Collecting Monitor Information*.

1.1.8 Remotely monitor the SAP system

PFM - Agent for Enterprise Applications can remotely monitor SAP system's performance.

This performance monitoring is applicable to the SAP system running on a host that is different from the host on which PFM - Agent for Enterprise Applications is running.

2

Performance Monitoring

This chapter describes performance monitoring using PFM - Agent for Enterprise Applications.

2.1 About performance monitoring

Performance monitoring is an important element in configuring and managing an SAP system environment. This section describes the purposes of using PFM - Agent for Enterprise Applications to monitor performance and presents examples of performance monitoring.

2.1.1 Purposes of performance monitoring

Use of PFM - Agent for Enterprise Applications for performance monitoring enables you to change and adjust the SAP system configuration. It also provides useful information for planning for future upgrades of system resources.

Following are the principal purposes for which you use performance monitoring:

- For analyzing performance data in the SAP system and identifying the causes of bottlenecks
- For analyzing performance data trends in the SAP system and for obtaining the characteristics of loads and their effects on the system resources
- For monitoring the SAP system to ensure that it is running normally

By continuously monitoring system performance, you can obtain the characteristics of loads in the SAP system environment and their effects on the system resources.

Performance monitoring is imperative in order to ensure stable operation of the SAP system. You can check the operation status of the SAP system by performing the following types of monitoring:

- Monitoring the SAP system's response times
- Monitoring SAP buffers
- Monitoring the SAP memory
- Monitoring system log information
- Monitoring CCMS alert information

Problems detected by PFM - Agent for Enterprise Applications can help you in performing further investigations and analyses using the SAP-provided operations management tool *CCMS*.

2.1.2 Selecting a baseline

Selection of a baseline involves examining performance measurement results and determining baseline values that, together, can be assumed to provide for a level of system operation that is free of problems.

The JP1/PFM products monitor system operations using the baseline values as threshold values. Therefore, selecting a baseline is an important task prior to performing performance monitoring.

We recommend that you obtain baseline measurements at the following times in order to maintain an appropriate baseline:

- When system operation is at peak status, such as when you test heavy loading on the operating environment, obtain measurements of the system's performance.
- Whenever you make changes in the system resources or operating environment, take baseline measurements again because the baseline depends significantly on the system configuration.

2.1.3 Examples of performance monitoring

(1) SAP system's response times

These examples monitor the SAP system's response times in order to check trends in performance throughout the entire SAP system.

(a) Records and fields related to response times

The following table lists and describes the records and fields that are related to response times.

Table 2–1: Records and fields related to response times

Record to be used	Field to be used	How to interpret the value (example)
PI or PI_DIA	ResponseTime	Average dialog step processing time
	DBRequestTime	Average time required to process a logical database request
	QueueTime	Average wait time in the dispatcher queue

(b) How to monitor

Monitoring the dialog response time

To monitor the dialog response time in the SAP system, you can use the `Dialog ResponseTime` alarm (field name: `ResponseTime`) that is provided as a monitoring template.

If `ResponseTime` is equal to or greater than the threshold value, performance of the entire SAP system might have become degraded. Determine the bottleneck by monitoring the load status of the entire SAP system and the database request time.

Monitoring the database request time

To monitor the database request time, you can use the `Dialog ResponseTime` report (field name: `DBRequestTime`) that is provided as a monitoring template.

If the value of `DBRequestTime` is high (exceeds 40% of the value of `ResponseTime - QueueTime` field), a problem might have occurred in buffering at the application server, in optimization of SQL statements (ABAP), or in the database server.

Monitoring the load status in the entire SAP system

To monitor the load status in the entire SAP system, you can use the `Dialog ResponseTime` report (field name: `QueueTime`) that is provided as a monitoring template.

If the value of `QueueTime` is high (exceeds 10% of the value of `ResponseTime` field), the workload in the entire SAP system might have become elevated.

(2) Monitoring SAP buffers

These examples monitor the SAP buffers in order to ensure that the SAP system is operating efficiently.

By using the SAP buffers efficiently, you can reduce the response times for applications that are executed frequently, such as repetitive jobs.

(a) Records and fields related to the SAP buffers

The following table lists and describes the records and fields that are related to the SAP buffers.

Table 2–2: Records and fields related to the SAP buffers

Record to be used	Field to be used	How to interpret the value (example)
PI or PI_BUFF	Program HitRatio %	Percentage of queries that did not need to access the database because the program was in the program buffer (buffer hit rate)
	CUA HitRatio %	Percentage of queries that did not need to access the database because the menu information was in the CUA buffer (buffer hit rate)
	GenericKey HitRatio %	Percentage of queries that did not need to access the database because the table data (multiple records) was in the generic key buffer (buffer hit rate)
	SingleRecord HitRatio %	Percentage of queries that did not need to access the database because the table data (1 record) was in the single record buffer (buffer hit rate)
PI_BUFF	Program Swap	Buffer-full swap count in the program buffer per minute. We recommend setting a value of 0 to this field.
	CUA Swap	Buffer-full swap count in the CUA buffer per minute. We recommend setting a value of 0 to this field.
	GenericKey Swap	Buffer-full swap count in the generic key buffer per minute. We recommend setting a value of 0 to this field.
	SingleRecord Swap	Buffer-full swap count in the single record buffer per minute. We recommend setting a value of 0 to this field.

(b) How to monitor

Monitoring the program buffer

You can monitor the program buffer hit rate and swap count.

To monitor the program buffer hit rate, you can use the `SAP Buffer Hitratio` report (field name: `Program HitRatio %`) that is provided as a monitoring template. If this value is low (less than 80%), the number of user requests (other than for repetitive jobs) might have increased.

To monitor the program buffer swap count, you can use the `SAP Buffer Hitratio` report (field name: `Program Swap`) that is provided as a monitoring template. If this value is greater than 0, the size of the program buffer might be too small.

Monitoring the buffer for menu information

You can monitor the buffer hit rate and swap count for menu information.

To monitor the buffer hit rate for menu information, you can use the `SAP Buffer Hitratio` report (field name: `CUA HitRatio %`) that is provided as a monitoring template. If this value is low (less than 80%), the volume of menu operations (other than for repetitive jobs) might have increased.

To monitor the swap count for menu information, you can use the `SAP Buffer Hitratio` report (field name: `CUA Swap`) that is provided as a monitoring template. If this value is greater than 0, the CUA buffer might be too small.

Monitoring the GenericKey buffer for table data

You can monitor the GenericKey buffer hit rate and swap count for table data.

To monitor the buffer hit rate for table data, use the `SAP Buffer Hitratio` report (field name: `GenericKey HitRatio %`) that is provided in the monitoring templates. If this value is low (less than 80%), the generic key buffer might be too small or there might be a problem in the table allocation method for the generic key buffer.

To monitor the buffer swap count for table data, use the `SAP Buffer Hitratio` report (field name: `GenericKey Swap`) that is provided in the monitoring templates. If this value is greater than 0, the generic key buffer might be too small.

Monitoring the SingleRecord buffer for table data

You can monitor the SingleRecord buffer hit rate and swap count for table data.

To monitor the buffer hit rate for table data, use the `SAP Buffer Hitratio` report (field name: `SingleRecord HitRatio %`) that is provided in the monitoring templates. If this value is low (less than 80%), the single record buffer might be too small or there might be a problem in the table allocation method for the generic key buffer.

To monitor the buffer swap count for table data, use the `SAP Buffer Hitratio` report (field name: `SingleRecord Swap`) that is provided in the monitoring templates. If this value is greater than 0, the single record buffer might be too small.

(3) Monitoring the SAP memory

This example monitors the SAP memory specific to an SAP system in order to check trends in performance degradation in the entire SAP system due to insufficient SAP memory area.

(a) Records and fields related to the SAP memory

The following table lists and describes the records and fields that are related to the SAP memory.

Table 2–3: Records and fields related to the SAP memory

Record to be used	Field to be used	How to interpret the value (example)
PI or PI_MEM	EsAct %	Current expansion memory use rate
	HeapAct %	Current heap area use rate
	PrivWpNo	Number of work processes placed in the PRIV mode
	R3PagingUsed %	Paging area use rate
	R3RollUsed %	Roll area use rate

(b) How to monitor

Monitoring the expansion memory use rate in the SAP memory

To monitor the expansion memory use rate in the SAP memory, you can use the `Extended Memory` alarm that is provided as a monitoring template.

If the `Extended Memory` alarm status is abnormal or a warning, there might not be enough extended memory area.

Monitoring the heap area use rate in the SAP memory

To monitor the heap area use rate in the SAP memory, you can use the `Heap Memory` alarm that is provided as a monitoring template.

If the `Heap Memory` alarm status is abnormal or a warning, there might not be enough heap area, or a dialog work process might have resulted in a short dump.

Monitoring the number of work processes that are in PRIV mode

To check the number of work processes that are in the PRIV mode, you can use the `SAP Memory Detail` drilldown report (field name: `PrivWpNo`) that is provided as a monitoring template.

If this value is 1 or greater, a dispatcher wait time might have increased.

Monitoring the paging area use rate in the SAP memory

To monitor the paging area use rate in the SAP memory, you can use the `Paging Area` alarm that is provided as a monitoring template.

If the `Paging Area` alarm status is abnormal or a warning, there might not be enough paging area.

Monitoring the roll area use rate in the SAP memory

To monitor the roll area use rate in the SAP memory, you can use the `Roll Area` alarm that is provided as a monitoring template.

If the Roll Area alarm status is abnormal or a warning, there might not be enough roll area, or a dialog work process might have been placed in PRIV mode.

(4) Monitoring SAP system logs and CCMS alerts

The SAP system outputs to the system log the events that have occurred and error information.

The SAP system is equipped with a Computer Center Management System (CCMS) that analyzes system operations management and loads.

PFM - Agent for Enterprise Applications can periodically output to a text file the system logs and alerts (alert information) that have occurred in CCMS's warning monitor.

You can use information in this text file to monitor the status of the SAP system by linking it to another program that monitors logs.

(a) How to monitor

Monitoring system logs

The system log information extraction function enables you to periodically output to a text file the system log information that is specific to the events and failures that have occurred in the SAP system.

This function outputs the following information:

- Time the message was recorded
- Server that recorded the message
- User that recorded the message
- Program that recorded the message
- Message number
- Message

For details, see *Chapter 5. Extracting System Log Information*.

Monitoring CCMS alert information

The CCMS alert information extraction function enables you to periodically output to a text file the warning events (alert information) that occur in CCMS's Alert Monitor.

This function outputs the following information:

- Alert ID
- ID of the MTE associated with the alert
- Severity of the alert
- General property
- Message

For details, see *Chapter 6. Extracting CCMS Alert Information*.

3

Installation and Setup

This chapter describes the procedures for installing and setting up PFM - Agent for Enterprise Applications.

3.1 Installation and setup in Windows

This section explains the procedures for installing and setting up PFM - Agent for Enterprise Applications.

3.1.1 What to check before installing and setting up PFM - Agent for Enterprise Applications in Windows

This section describes the items to be checked before installing and setting up PFM - Agent for Enterprise Applications.

(1) Supported OSs

PFM - Agent for Enterprise Applications can run on the following operating systems (OSs):

- Windows Server 2012
- Windows Server 2016

(2) Network environment setup

This subsection describes the network environment needed for Performance Management operation.

(a) Setting IP addresses

You must set up the environment for a PFM - Agent host in such a manner that IP addresses can be determined from the host name. PFM - Agent can run only in an environment in which IP addresses can be resolved.

For the monitoring host name (name used as the host name of the Performance Management system), you can use the real host name or an alias name.

- When the real host name is used as the monitoring host name:
In a Windows system, set the environment in such a manner that the IP address can be resolved by the host name that is obtained by the `hostname` command.
- When an alias name is used as the monitoring host name:
Set the environment in such a manner that the IP address can be resolved by this alias name.

For details about the monitoring host name setting, see the chapter that describes installation and setup in the *JPI/Performance Management Planning and Configuration Guide*.

To set host names and IP addresses, use one of the following methods:

- Performance Management's host information file (`jpchosts` file)
- `hosts` file
- DNS

Notes

- The IP addresses specified in the `jpchosts` file cannot be used to resolve IP addresses for the names of hosts that are monitored by PFM - Agent (such as a host name specified in the `ASHOST` item).
- Performance Management can be run in a DNS environment, but it does not support fully qualified domain names (FQDNs). When you specify a monitoring host name, do not include the domain name.

- If you use Performance Management in multiple LAN environments, use the `jpchosts` file to set IP addresses. For details, see the chapter that describes installation and setup in the *JP1/Performance Management Planning and Configuration Guide*.
- Performance Management does not run on a host where dynamic IP addresses are assigned by DHCP. Set fixed IP addresses for all hosts on which Performance Management is to be installed.

(b) Setting port numbers

The port numbers listed in the table below are assigned by default to the Performance Management program services. An available port number is assigned automatically to any other service or program each time such a service is started. You must use fixed port numbers when Performance Management is used in a firewall environment. For details about how to fix port numbers, see the chapter that describes installation and setup in the *JP1/Performance Management Planning and Configuration Guide*.

Table 3–1: Default port numbers used by the Performance Management program services (for Windows)

Service description	Service name	Parameter	Port number	Remarks
Service configuration information management function	Name Server	<code>jp1pcnsvr</code>	22285	Port number used by PFM - Manager's Name Server service. This port number is set at all hosts of Performance Management.
Service status management function	Status Server	<code>jp1pcstatsvr</code>	22350	Port number used by the Status Server service of PFM - Manager and PFM - Base. This port number is set at the host where PFM - Manager and PFM - Base are installed.
JP1/SLM linkage function	JP1/ITSLM	--	20905	Default port number set in JP1/SLM

Legend:

--: Not applicable

You should set up your network in such a manner that communication can be established with the port numbers used by these Performance Management program services.

(3) OS user permission required for installation

Make sure that you are using an account that has the Administrators permission when you install PFM - Agent for Enterprise Applications.

(4) Required programs

This subsection describes the programs that are required to install PFM - Agent for Enterprise Applications. The following shows the configuration of the programs.

Figure 3–1: Program configuration (when installing the SAP system on the same host on which PFM - Agent for Enterprise Applications is installed)

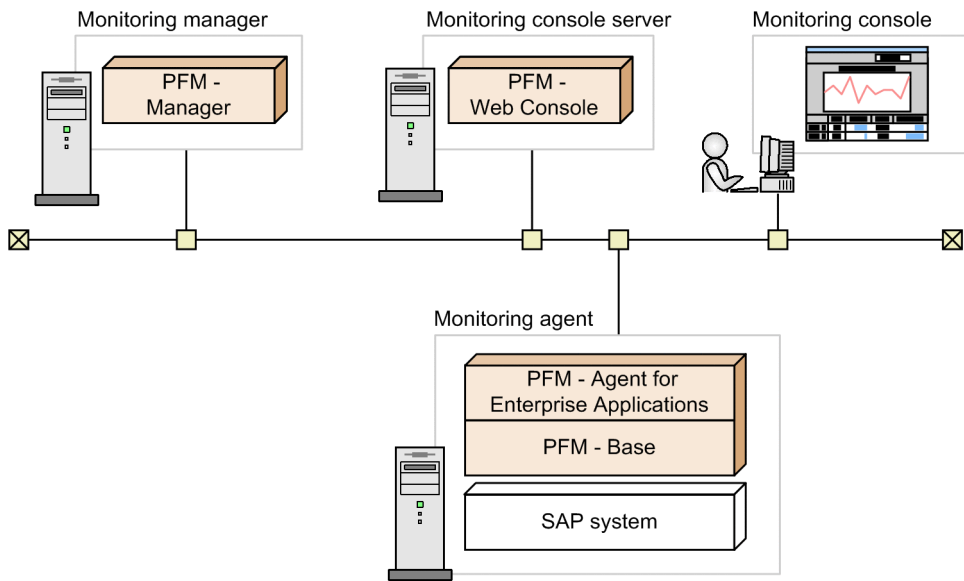

Legend:

- : Program provided by Performance Management
- : Required program

Figure 3–2: Program configuration (when remotely monitoring the SAP system installed on a host different from the one on which PFM - Agent for Enterprise Applications is installed)

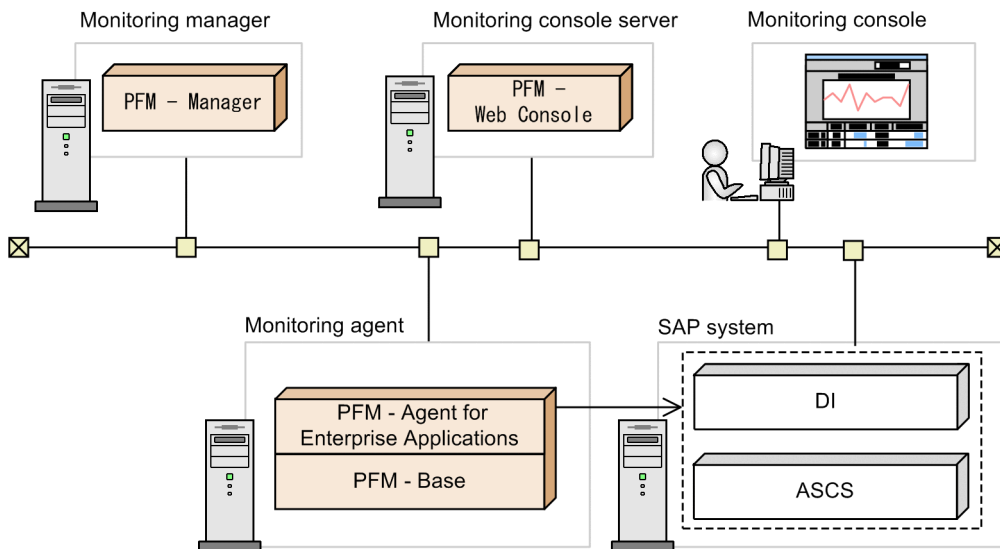

Legend:

- : Program provided by Performance Management
- : Required program
- ASCs : ABAP Central Services instance
- DI : Dialog instance
- : Monitoring

(a) Programs that can be monitored

PFM - Agent for Enterprise Applications can monitor the following program:

- SAP NetWeaver^{#1#2}

#1

This program must be installed on only host that contains a central instance with dialog service (primary application server instance) or a dialog instance (additional application server instance).

#2

For details about the versions of SAP NetWeaver, see the *Release Notes*.

(b) Performance Management programs

PFM - Agent and PFM - Base must be installed on the monitoring agent. PFM - Base is a prerequisite program for PFM - Agent. You only need one PFM - Base, even when multiple PFM - Agents and PFM - RMs are installed on the same host.

Note that if you install PFM - Manager and PFM - Agent on the same host, PFM - Base is not required.

If you install PFM - Manager or PFM - Base on a PFM - Agent host, make sure that you install version 12-00. For details about the relationship between hosts on which Performance Management programs are installed and their versions, see the chapter that describes compatibility of versions in a system configuration in the *JPI/Performance Management Planning and Configuration Guide*.

PFM - Manager and PFM - Web Console are required in order to use PFM - Agent for Enterprise Applications to monitor SAP system operation.

(5) Installing and setting up in a cluster system

The required network environment and program configuration are different for a cluster system than for a normal non-cluster system. In a cluster system, installation and setup are required at both the executing and the standby nodes. For details, see *Chapter 4. Operation in a Cluster System*.

(6) Preparing for data collection in the event of a failure

In the event of a problem, you might need to collect such data as memory dumps and user mode process dumps. Specify the settings beforehand so that memory dumps and user mode process dumps will be output in the event of a problem.

(a) User mode process dump output settings

In the event that an application program terminates abnormally, you can immediately obtain a user mode process dump to investigate the cause of the error by setting the following registry entry:

```
HKEY_LOCAL_MACHINE\SOFTWARE\Microsoft\Windows\Windows Error Reporting
\LocalDumps
```

In this registry key, specify the following registry values:

- DumpFolder: REG_EXPAND_SZ *dump-output-folder-name*
(The output folder must have write permissions.)
- DumpCount: REG_DWORD *number-of-dumps-to-be-retained*

- DumpType: REG_DWORD 2

Notes

- If you set the registry entry, a user mode process dump is output for other application programs in addition to JP1 programs. Keep this in mind when you specify the user mode process dump output settings.
- To create a user mode process dump, disk space equivalent to the size of that user mode process dump is required. Make sure that the specified dump output folder has sufficient disk space.

(7) Notes on installation

- According to a status such as the system status, file expansion required for installation might fail. If installation fails, try the installation again. If installation fails again, collect all the files in the %windir%\TEMP\HCDINST folder, collect the materials by using the jpcras command, and then contact the system administrator.
- Because the Windows Event Viewer sometimes references files associated with JP1/PFM, make sure that the Event Viewer is stopped before you start installing PFM - Agent for Enterprise Applications.
- Installation on a virtual disk that was created in following platforms storage pool is not supported.
 - Windows Server 2012
 - Windows Server 2016

3.1.2 Flow of tasks for installation and setup in Windows

This subsection describes the flow of tasks for installing and setting up PFM - Agent for Enterprise Applications.

Figure 3–3: Flow of tasks for installation and setup

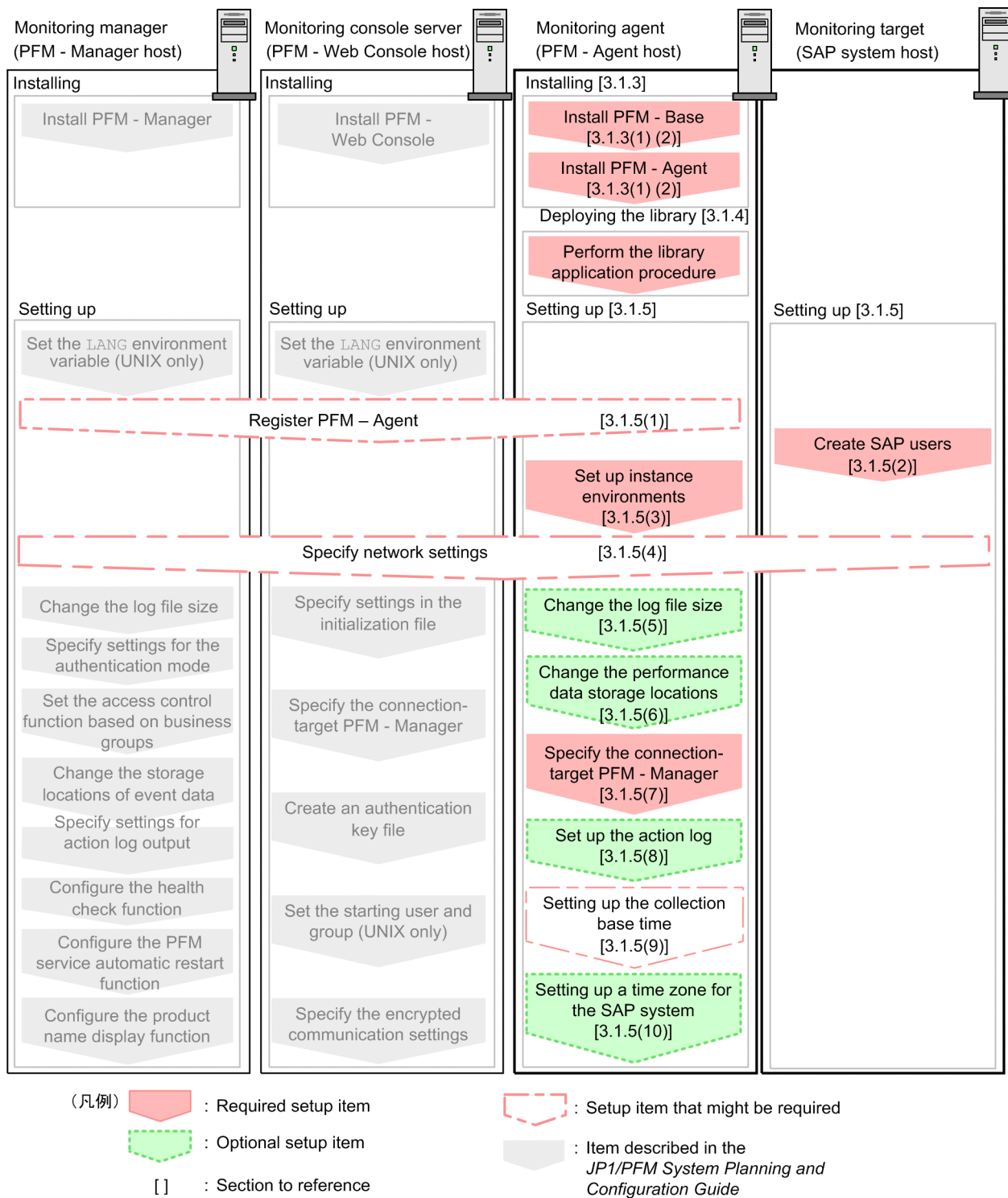

For details about how to install and set up PFM - Manager and PFM - Web Console, see the chapter that describes installation and setup in the *JP1/Performance Management Planning and Configuration Guide*.

3.1.3 Installation procedure in Windows

This subsection describes the program installation order for PFM - Agent for Enterprise Applications and how to install the program from the distribution media.

(1) Program installation order

You must install PFM - Base before you install a PFM - Agent. PFM - Agent cannot be installed on a host where PFM - Base has not been installed.

To install PFM - Agent and PFM - Manager on the same host, install PFM - Manager first and then PFM - Agent. If you are upgrading the Store database from version 1.0 to 2.0, the setup method depends on the order in which PFM - Agent and PFM - Manager or PFM - Base are installed. For details about how to set up Store version 2.0, see [3.6.2 Updating the Store version to 2.0](#).

Multiple PFM - Agents installed on the same host can be installed in any order.

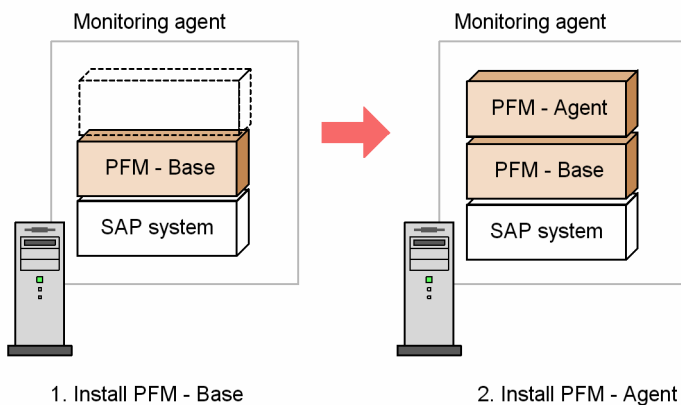

(2) Installing the program

There are two ways to install the Performance Management program on a Windows host. One uses the distribution media, and the other uses JP1/Software Distribution for remote installation. For details about the method that uses JP1/Software Distribution, see the *JP1/Software Distribution Administrator's Guide Volume 1*.

Note:

If the OS's user account control (UAC) function is enabled, a user account control dialog box might be displayed during installation. If this dialog box is displayed, click the **Continue** button to continue installation. If you click the **Cancel** button, installation will be canceled.

When the UAC function is not used, you must log in to the host to be installed with Administrators permissions.

To install from the distribution media. See the manual of the supplied medium for how to use the integrated installer.

1. At the host where PFM - Agent for Enterprise Applications is to be installed, log on as a user with Administrators permission.
2. Stop all Performance Management services running on the local host.
Stop the Performance Management services on the physical and logical hosts. For details about how to stop services, see the chapter that describes starting and stopping Performance Management in the *JP1/Performance Management Users' Guide*.
3. Insert the provided medium and run the installer.
Install the program by following the installer's instructions.
The following items, set when PFM - Manager or PFM - Base is installed, are displayed so that you can check them:
 - User information
 - Installation folder

- Program folder

4. Click the Install button to start the installation.

Reference

For the installation folder, the one specified when PFM - Manager or PFM - Base was installed is assumed.

3.1.4 Library application procedure

This section describes how to apply a library.

To use PFM - Agent for Enterprise Applications, the SAP NetWeaver RFC Library provided by SAP must first be installed on the machine where PFM - Agent for Enterprise Applications is installed.

For details about how to obtain and install the SAP NetWeaver RFC Library, see the *Release Notes*.

3.1.5 Setup procedure in Windows

This subsection describes the setup that is required before you can use PFM - Agent for Enterprise Applications.

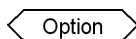
 indicates a setup item whose requirement depends on the environment being used or an optional setup item when you wish to change a default setting.

(1) Registering PFM - Agent for Enterprise Applications to PFM - Manager and PFM - Web Console

To use PFM - Manager and PFM - Web Console for centralized management of PFM - Agents, PFM - Agent for Enterprise Applications must be registered into PFM - Manager and PFM - Web Console.

If the version of PFM - Manager is 09-00 or later, PFM - Agent is registered automatically, in which case there is no need to perform the procedure described here. However, any data model version of PFM - Agent that is not included in the *Release Notes* for PFM - Manager must be registered manually. For details about the data model version of PFM - Agent for Enterprise Applications, see [Appendix I. Version Compatibility](#).

The following shows the procedure for registering a PFM - Agent.

Figure 3–4: Procedure for registering a PFM - Agent

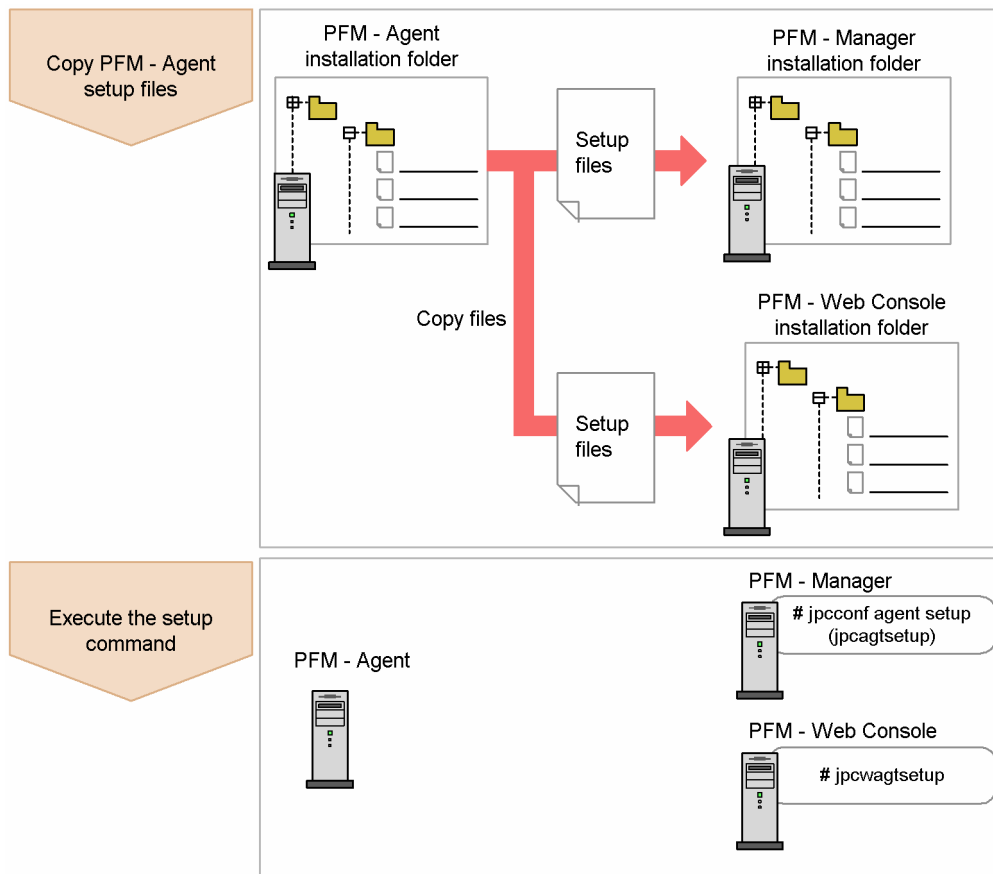

Notes

- Register PFM - Agent before you set up instance environments.
- If you are adding the same version of PFM - Agent for Enterprise Applications to a Performance Management system in which information about PFM - Agent for Enterprise Applications has already been registered, there is no need to register the PFM - Agents.
- If you install a different version of PFM - Agent for Enterprise Applications on a separate host, set up the old version first and then the new version.
- If you have installed PFM - Agent on the same host as PFM - Manager, the `jpcconf agent setup` command executes automatically and the message `KAVE05908-I New agent setup (Pfm-Agent-service-key) ended successfully. (version=version)` is output to the common message log. Check the result; if the command did not execute correctly, re-execute it. For details about executing commands, see the chapter that describes commands in the manual *JPI/Performance Management Reference*.

(a) Copying the setup files for PFM - Agent for Enterprise Applications

Copy the setup files from the host where PFM - Agent for Enterprise Applications was installed to the host where PFM - Manager and PFM - Web Console were installed.

To copy the setup files:

1. Stop PFM - Web Console if it is running.
2. Copy the PFM - Agent setup files in the binary mode.

The table below shows the source and target locations of the files to be copied.

Table 3–2: Setup files to be copied

PFM - Agent setup file	Source		
	PFM program name	OS	Target folder or directory
<i>installation-folder</i> \setup\jpcagtmw.EXE	PFM - Manager	Windows	<i>PFM-Manager-installation-folder</i> \setup
<i>installation-folder</i> \setup\jpcagtmu.Z		UNIX	/opt/jp1pc/setup/
<i>installation-folder</i> \setup\jpcagtmw.EXE	PFM - Web Console	Windows	<i>PFM-Web-Console-installation-folder</i> \setup
<i>installation-folder</i> \setup\jpcagtmu.Z		UNIX	/opt/jp1pcwebcon/setup/

(b) Executing the setup command at the PFM - Manager host

To use PFM - Manager to set up PFM - Agent for Enterprise Applications, execute the following command:

```
jpcconf agent setup -key EAP
```

Note

An error might occur if the `jpcconf agent setup` command is executed at a local host where Performance Management programs and services have not stopped completely. If an error occurs, check that all Performance Management programs and services have stopped completely and then re-execute the `jpcconf agent setup` command.

After completing this step, you can delete the PFM - Agent setup files from the PFM - Manager host.

(c) Executing the setup command at the PFM - Web Console host

To use PFM - Web Console to set up PFM - Agent for Enterprise Applications, execute the following command:

```
jpcwagtsetup
```

After completing this step, you can delete the PFM - Agent setup files from the PFM - Web Console host.

(2) Creating SAP users that are to be used by PFM - Agent for Enterprise Applications

To collect performance information, PFM - Agent for Enterprise Applications uses RFC (communication protocol of SAP AG) to execute the external management interfaces defined in the SAP system. Therefore, you must prepare in advance the SAP system users who are to be used by PFM - Agent for Enterprise Applications.

This subsection describes the user types, passwords, and authorizations for the SAP users who are created in the SAP system.

(a) User types

The following types of SAP users can be used by PFM - Agent for Enterprise Applications:

- Dialog

- System
- Communication
- Service

(b) Characters permitted for passwords

Define passwords for the SAP users. A password can consist of single-byte numeric characters (from 0 to 9), single-byte alphabetic characters (from a to z, A to Z), and the following single-byte symbols:

!, @, \$, %, &, /, (,), =, ?, ', `*, +, ~, #, -, _., :, {, [,], }, <, >, |

(c) Required authorizations

You must set the following authorizations (authorization objects) for the users:

- Authorizations required for a user to establish RFC connection with function modules (S_RFC)
- Authorizations required in order to use external management interfaces (S_XMI_PROD)

For the value of each authorization, assign a value shown in the tables below or use the built-in configurations (S_RFC_ALL and S_XMI_ADMIN) that specify an asterisk (*) for all items.

Table 3–3: Authorizations required for a user to establish RFC connection with function modules (S_RFC)

Authorization	Description	Value
RFC_TYPE	Type of RFC object to be protected	FUGR (function group)
RFC_NAME	RFC name to be protected	*
ACTVT	Activity	1 6 (execution)

Table 3–4: Authorizations required in order to use external management interfaces (S_XMI_PROD)

Authorization	Description	Value
EXTCOMPANY	Company name of the external management tool	HITACHI
EXTPRODUCT	Program name of the external management tool	JP1
INTERFACE	Interface ID	*

(3) Setting up instance environments

You must set instance information for each SAP system that is to be monitored by PFM - Agent for Enterprise Applications. You perform the instance information setting at the PFM - Agent host.

The table below lists and describes the instance information items that are to be specified. Check this information before you start the setup procedure. For details about the instance information for an SAP system, see the SAP system documentation.

Table 3–5: Instance information for PFM - Agent for Enterprise Applications

Item	Description	Permitted value	Default value
SID	ID of the SAP system that is to be monitored	Character string (up to 8 bytes)	--

Item	Description	Permitted value	Default value
SERVER ^{#1}	SAP instance name that is to be monitored (the SAP instance name that has a dialog service, and which can be verified by transaction code SM51)	Character string (up to 20 bytes)	Instance name specified in <code>-inst</code> in the <code>jpccconf inst setup</code> command
ASHOST ^{#1}	Host name of the connection-target application server (the SAP local host, which can be verified by transaction code SM51)	Character string (up to 100 bytes)	Local host name
SYSNR	System number of the SAP system	Numeric characters (up to 2 bytes)	00
CLIENT	Client name to which the SAP user belongs (system number assigned to the connection-target dialog instance)	Numeric characters (up to 3 bytes)	000
USER	SAP user name	Character string (up to 12 bytes)	--
EXTPWD	Whether to use an extended password to connect to the SAP system	Y or N <ul style="list-style-type: none"> Y: Use an extended password. N: Do not use an extended password. 	Y
PASSWD	Password of the SAP user	When an extended password is used: Up to 40 single-byte characters When an extended password is not used: Up to 8 single-byte characters	--
DELAYCONNECTION	Timing of the connection to the SAP system	Y or N <ul style="list-style-type: none"> Y: Connect to the SAP system only when performance data is collected. The Agent Collector service is started regardless of the operating status of the SAP system at the time of connection establishment. N: Connect to the SAP system when the Agent Collector service starts. The Agent Collector service is not started if the SAP system is not active at the time of connection establishment. 	N
Store Version ^{#2}	Store version to be used. For details about the Store version, see 3.6.2 Updating the Store version to 2.0 .	{1.0 2.0}	2.0

Legend:

--: None

#1

To use the remote monitoring function, you have to set both the SAP instance name to be monitored and the host name of the SAP system.

#2

This setting is required when the version of PFM - Agent for Enterprise Applications is 09-00 or later, and the version of PFM - Base or PFM - Manager on the same host is 08-11 or later, and you are setting up an instance environment for the first time.

Note

- If no instance environment has been set up, the PFM - Agent for Enterprise Applications service cannot be started.

You use the `jpccconf inst setup` command to construct an instance environment.

To construct an instance environment:

1. Execute the `jpcconf inst setup` command with the service key and instance name specified.

For example, to construct an instance environment for the instance named `o246bciSD500` for PFM - Agent for Enterprise Applications, execute the following command:

```
jpcconf inst setup -key EAP -inst o246bciSD500
```

Although you can use any instance name in PFM - Agent for Enterprise Applications, to simplify management we recommend that you use an instance name that identifies the SAP system that is to be monitored. Normally, a name in the format *host-name_SAP-system-ID_system-number* is assigned to an instance for an SAP system.

Note that no underscore (`_`) is allowed in the `jpcconf inst setup` command. For example, if the instance name of SAP system is `o246bci_SD5_00`, specify `o246bciSD500` as the instance name of PFM - Agent for Enterprise Applications.

2. Specify instance information for the SAP system.

Enter the information shown in [Table 3-5](#), in accordance with the command's instructions. You cannot omit any requested items. To use a displayed value (which is the default) press the **Enter** key.

Once you have entered all items, the instance environment is constructed. The following describes constructed instance environments:

- Organization of folders for instance environments

Instance environments are configured in the following folders:

- For physical host operation: *installation-folder*\agtm
- For logical host operation: *environment-directory*#\jplpc\agtm

#

The environment directory is located on the shared disk that was specified when the logical host was created.

The following table shows the organization of the folders for instance environments.

Table 3–6: Organization of folders for instance environments

Folder and file names		Description	
agent	<i>instance-name</i>	jpcagt.ini	Agent Collector service startup initialization file
		jpcagt.ini.model#	Model file for the Agent Collector service startup initialization file
		jpcMcollect.ini	SAP communications process parameters file
		j3alget.ini	Environment parameters file for CCMS Alert Monitor Command (PD_ALMX) records
		j3slget.ini	Environment parameters file for System Log Monitor Command (PD_SLMX) records
		log	Storage folder for log files
store	<i>instance-name</i>	jpcsto.ini	Agent Store service startup initialization file
		jpcsto.ini.model#	Model file for the Agent Store service startup initialization file
		*.DAT	Data model definition file
		dump	Export folder

Folder and file names			Description
store	<i>instance-name</i>	backup	Backup folder
		import	Import folder (for Store version 2.0)
		log	Storage folder for log files
		partial	Partial backup folder (for Store version 2.0)
		STPD	Performance data storage folder for the PD record type (for Store version 2.0)
		STPI	Performance data storage folder for the PI record type (for Store version 2.0)
		STPL	Performance data storage folder for the PL record type (for Store version 2.0)

#

You can use this file to restore the settings that were in effect before the instance environment was constructed.

- Service ID for an instance environment

The service ID for an instance environment is a character string that consists of a product ID, function ID, instance number, instance name, and host name. If the product name is set to display, the service ID would be *instance-name [host-name] program-name*.

For example, service ID MA1o246bcisD500 [host01] represents the following instance environment:

- Product ID: M
- Function ID: A
- Instance number: 1
- Instance name: o246bcisD500
- Host name: host01

For details about the service ID, see the appendix in the *JPI/Performance Management Planning and Configuration Guide*.

- Windows service name for an instance environment

The following are the Windows service names for instance environments:

- Agent Collector service: PFM – Agent for R/3 *instance-name*
- Agent Collector service for logical host operation: PFM – Agent for R/3 *instance-name [logical-host-name]*
- Agent Store service: PFM – Agent Store for R/3 *instance-name*
- Agent Store service for logical host operation: PFM – Agent Store for R/3 *instance-name [logical-host-name]*

For details about the Windows service names, see the appendix in the *JPI/Performance Management Planning and Configuration Guide*.

(4) Specifying network settings Option

You must specify network settings only when you change the network configuration where Performance Management is used.

You can set the following two network settings items:

- IP addresses

Set this information to use Performance Management in a network that is connected to multiple LANs. To set multiple IP addresses, define the host names and IP addresses in the `jpchosts` file. Make sure that the settings in the `jpchosts` file are consistent throughout the entire Performance Management system.

For details, see the chapter that describes installation and setup in the *JPI/Performance Management Planning and Configuration Guide*.

- Port numbers

You can set the port numbers used by Performance Management. To avoid confusion during operation, make sure that the specified port numbers and service names are consistent throughout the entire Performance Management system.

For details about setting port numbers, see the chapter that describes installation and setup in the *JPI/Performance Management Planning and Configuration Guide*.

(5) Changing the log file size Option

Performance Management's operating status is output to a log file unique to Performance Management. This setting is required only when you wish to change this file size.

For details, see the chapter that describes installation and setup in the *JPI/Performance Management Planning and Configuration Guide*.

(6) Changing the performance data storage locations Option

These settings are required only when you wish to change the storage location, backup folder, export folder, partial backup folder, or import folder for the database that stores the performance data managed by PFM - Agent for Enterprise Applications.

The default storage locations for the performance data are as follows:

Storage location	Folder name
Database	<code>installation-folder\agtm\store\instance-name\</code>
Backup	<code>installation-folder\agtm\store\instance-name\backup\</code>
Export	<code>installation-folder\agtm\store\instance-name\dump\</code>
Partial backup (for Store version 2.0)	<code>installation-folder\agtm\store\instance-name\partial\</code>
Import (for Store version 2.0)	<code>installation-folder\agtm\store\instance-name\import\</code>

For details, see [3.6.1 Changing the performance data storage location](#).

(7) Specifying the connection-target PFM - Manager for PFM - Agent for Enterprise Applications

On the host where a PFM - Agent is installed, you must specify the PFM - Manager that manages that PFM - Agent. You use the `jpccconf mgrhost define` command to set the connection-target PFM - Manager.

Notes

- There can be only one PFM - Manager as the connection destination even when multiple PFM - Agents are installed on the same host. Different PFM - Managers cannot be specified for the various PFM - Agents.

- If a PFM - Agent and PFM - Manager are installed on the same host, that PFM - Manager on the local host is automatically the connection-target PFM - Manager; you cannot change the connection-target PFM - Manager to some other PFM - Manager.

To specify the connection-target PFM - Manager:

1. Stop all Performance Management services.

Before you start the setup procedure, you must terminate all Performance Management services that are running on the local host. For details about stopping services, see the chapter that describes starting and stopping services in the *JPI/Performance Management User's Guide*.

If a Performance Management service remains active during execution of the `jpccconf mgrhost define` command, a message is displayed that asks you to terminate the program.

2. Execute the `jpccconf mgrhost define` command with the host name of the connection-target PFM - Manager specified.

For example, if the connection-target PFM - Manager is on host `host01`, specify the command as follows:

```
jpccconf mgrhost define -s host01
```

(8) Setting up the action log Option

You can log information in the action log when, for example, PFM services start and stop, and the status of the connection to PFM - Manager changes. The action log stores history information that is output in conjunction with the alarms for thresholds related to system load and other conditions.

For details about how to set up the action log, see [Appendix J. Outputting Action Log Data](#).

(9) Setting up the collection base time

To use the remote monitoring function, you have to set the collection base time for the system log information extraction function and the CCMS alert information extraction function. For details about how to set the environment parameters file and the relevant settings, see [5.3 Environment parameters file](#) and [6.3 Environment parameters file](#).

(10) Setting up a time zone for the SAP system Option

To use the remote monitoring function, you have to set a time zone (time difference from UTC) for the SAP system, which will be taken into consideration by the system log information extraction function. For details about how to set the environment parameters file and the relevant settings, see [5.3 Environment parameters file](#) and [6.3 Environment parameters file](#).

3.1.6 Notes about installation and setup in Windows

(1) Notes about environment variables

Performance Management uses the `JPC_HOSTNAME` environment variable. Do not set a user-specific `JPC_HOSTNAME` environment variable. If such an environment variable is set, Performance Management will not function correctly.

(2) Installing and setting up multiple Performance Management programs on the same host

Performance Management enables you to install PFM - Manager, PFM - Web Console, and PFM - Agent on the same host. This subsection provides notes about such an installation.

- If you install PFM - Manager and PFM - Agent on the same host, there is no need to install PFM - Base. In this case, PFM - Agent requires PFM - Manager; therefore, install PFM - Manager first, and then install PFM - Agent.
- PFM - Base and PFM - Manager cannot be installed on the same host. To install PFM - Manager on a host where PFM - Base and PFM - Agent are already installed, uninstall all Performance Management programs (other than PFM - Web Console), and then install PFM - Manager and PFM - Agent in this order. Similarly, to install PFM - Base on a host where PFM - Manager and PFM - Agent are already installed, uninstall all Performance Management programs (other than PFM - Web Console), and then install PFM - Base and PFM - Agent in this order.
- If you install PFM - Agent on a host where PFM - Manager is already installed, the PFM - Manager on the local host becomes the connection-target PFM - Manager. In such a case, you can no longer change the connection-target PFM - Manager to a PFM - Manager on a remote host. Therefore, if you want to connect to a PFM - Manager on a remote host, make sure that PFM - Manager has not been installed already on the target host.
- If a PFM - Agent already exists on the host where PFM - Manager is being installed, the local host is redesignated as the connection-target PFM - Manager for that PFM - Agent. The resulting settings are output to the common message log file; check the results.
- If PFM - Web Console already exists on a host where PFM - Agent is to be installed, close all browser windows before starting installation.
- When a new Performance Management program is installed, the default is that the status management function is enabled. However, if you upgrade from version 07-00 to 08-00 or later, the settings for the status management function disabled. To change the status management function settings, see the chapter that describes Performance Management failure detection in the *JPI/Performance Management User's Guide*.

Tip

To improve system performance and reliability, we recommend that you run PFM - Manager, PFM - Web Console, and PFM - Agent on separate hosts.

(3) Upgrading

For notes about upgrading the Performance Management programs, see the notes on version upgrades in the chapter on installation and setup in the *JPI/Performance Management Planning and Configuration Guide*.

For details about the precautions to be observed when upgrading from an older version of PFM - Agent, see [Appendix H. Migration Steps and Notes on Migration](#). For details about how to upgrade PFM - Agent, see the relevant appendix in the *JPI/Performance Management Planning and Configuration Guide*.

(4) Notes about an SAP system employing an ASCS instance configuration

To monitor the SAP system, you need to set up an instance environment for each host that contains a central instance with dialog service (primary application server instance) or a dialog instance (additional application server instance).

(5) Notes on using the remote monitoring function

- To use remote monitoring, you have to synchronize the system clocks of different hosts by using NTP or different means.

- If the time zone varies between the host on which PFM - Agent is running and the one on which the monitored SAP system is running, adopt the time zone set for the SAP system by following the steps described in [3.1.5 \(10\) Setting up a time zone for the SAP system](#).

(6) Restrictions on using remote desktop connections for management

When installation or setup operation is performed by using remote desktop connections for management, the following restrictions apply:

- Remote desktop connections can be used only for the installation, setup, uninstallation, and maintenance purposes.
- When the above operation is performed, you must use a session 0 connection instead of regular remote desktop connection. To use session 0, specify the /console option as follows when you start a remote desktop connection application on the applicable operation terminal (client):

```
mstsc.exe /console
```

Note: mstsc.exe is an executable file that opens a remote desktop connection. Note that only one user with Administrator permissions can use session 0 connections at a time.

(7) Other notes

- If connection dialogue instance of the SAP system does not have an MTE name for the acquisition, no performance data will be collected from the field of some records because this field does not exist in the connection-target dialog instance. As a result, a warning message (KAVF14173-W) is output to the common message log and Windows event log. This warning message is output regardless of the settings for LOG (whether or not the collected performance data is to be recorded in the Store database) in each record.
- If you attempt to install PFM - Agent for Enterprise Applications while Performance Management programs and services are running or while other programs that reference Performance Management files (such as Windows Event Viewer) are running, a message prompting for a system restart might be displayed. If this occurs, restart the system according to the message and complete the installation.
- If you attempt to install PFM - Agent for Enterprise Applications while Performance Management programs and services are running or while other programs that reference Performance Management files (such as Windows Event Viewer) are running, file expansion might fail if there is not enough disk space or if you do not have directory permission. In such a case, terminate all such programs and then re-install PFM - Agent for Enterprise Applications. If there is not enough disk space or you do not have directory permission, resolve the problem and then re-install PFM - Agent for Enterprise Applications.
- Before you install Performance Management programs, check to see if any security-related programs, such as those described below, are installed. If such a program is installed, take appropriate action according to the information provided below.
 - Security monitoring program
Terminate the security monitoring program or change its settings so that installation of the Performance Management programs will not be affected.
 - Virus detection program
We recommend that you terminate any virus detection program before you install the Performance Management programs.
If a virus detection program is running during installation of a Performance Management program, it might slow down the installation process, the installation might fail, or the program might not install correctly.
 - Process monitoring program
Terminate the process monitoring program or change its settings so that it does not monitor the services and processes of Performance Management or the services and processes of common components.

Installation of a Performance Management program might fail if any of these services or processes is started or stopped by the process monitoring program during the installation process.

- When this product is first installed and the **Programs and Features** dialog box is opened, the icon displayed for the product may change immediately from the originally displayed icon. This problem relates only to the icon, and does not affect product operation.
- This product does not support communications using IPv6 addresses. If you want to use this product in an operating system that supports IPv4/IPv6 dual stacking, the IP address that is calculated from the SAP host name on the connection destination must be resolvable by using IPv4. In this case, you must not set the environment variable `SAP_IPv6_ACTIVE` (which is used for IPv6 communications with the SAP system) in the execution environment for this product.

3.2 Installation and setup in Linux

This section explains the procedures for installing and setting up PFM - Agent for Enterprise Applications.

3.2.1 What to check before installing and setting up PFM - Agent for Enterprise Applications in Linux

This section describes the items to be checked before installing and setting up PFM - Agent for Enterprise Applications.

(1) Supported OSs

PFM - Agent for Enterprise Applications can run on the following operating systems (OSs):

- Linux

(2) Network environment setup

This subsection describes the network environment needed for Performance Management operation.

(a) Setting IP addresses

You must set up the environment for a PFM - Agent host in such a manner that IP addresses can be determined from the host name. PFM - Agent can run only in an environment in which IP addresses can be resolved.

For the monitoring host name (name used as the host name of the Performance Management system), you can use the real host name or an alias name.

- When the real host name is used as the monitoring host name:
In a Linux system, set the environment in such a manner that the IP address can be resolved by the host name that is obtained by the `uname -n` command. Note that in a Linux system, you can also use the `hostname` command to obtain the host name.
- When an alias name is used as the monitoring host name:
Set the environment in such a manner that the IP address can be resolved by this alias name.

For details about the monitoring host name setting, see the chapter that describes installation and setup in the *JPI/Performance Management Planning and Configuration Guide*.

To set host names and IP addresses, use one of the following methods:

- Performance Management's host information file (`jpchosts` file)
- `hosts` file
- DNS

Notes

- The IP addresses specified in the `jpchosts` file cannot be used to resolve IP addresses for the name of hosts that are monitored by PFM - Agent (such as a host name specified in the `ASHOST` item).
- Performance Management can be run in a DNS environment, but it does not support fully qualified domain names (FQDNs). When you specify a monitoring host name, do not include the domain name.

- If you use Performance Management in multiple LAN environments, use the `jpchosts` file to set IP addresses. For details, see the chapter that describes installation and setup in the *JP1/Performance Management Planning and Configuration Guide*.
- Performance Management does not run on a host where dynamic IP addresses are assigned by DHCP. Set fixed IP addresses for all hosts on which Performance Management is to be installed.

(b) Setting port numbers

The port numbers listed in the table below are assigned by default to the Performance Management program services. An available port number is assigned automatically to any other service or program each time such a service is started. You must use fixed port numbers when Performance Management is used in a firewall environment. For details about how to fix port numbers, see the chapter that describes installation and setup in the *JP1/Performance Management Planning and Configuration Guide*.

Table 3–7: Default port numbers used by the Performance Management program services (for Linux)

Service description	Service name	Parameter	Port number	Remarks
Service configuration information management function	Name Server	<code>jp1pcnsvr</code>	22285	Port number used by PFM - Manager's Name Server service. This port number is set at all hosts of Performance Management.
Service status management function	Status Server	<code>jp1pcstatsvr</code>	22350	Port number used by the Status Server service of PFM - Manager and PFM - Base. This port number is set at the host where PFM - Manager and PFM - Base are installed.
JP1/SLM linkage function	JP1/ITSLM	--	20905	Default port number set in JP1/SLM

Legend:

--: Not applicable

You should set up your network in such a manner that communication can be established with the port numbers used by these Performance Management program services.

(3) OS user permission required for installation

Make sure that you are using an account that has the superuser permission when you install PFM - Agent for Enterprise Applications.

(4) Required programs

This subsection describes the programs that are required in order to install PFM - Agent for Enterprise Applications. The following shows the configuration of the programs.

Figure 3–5: Program configuration (when installing the SAP system on the same host on which PFM - Agent for Enterprise Applications is installed)

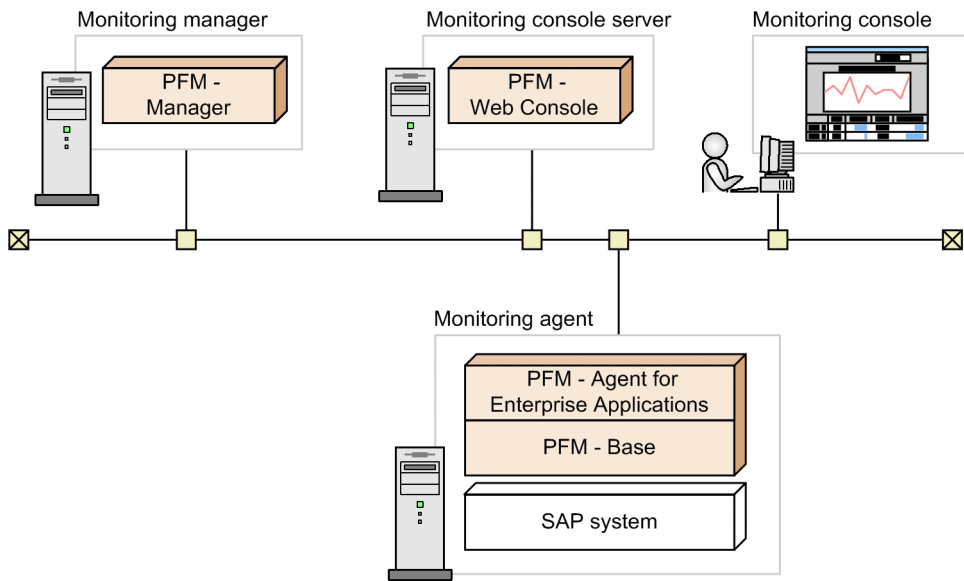

Legend:

- : Program provided by Performance Management
- : Required program

Figure 3–6: Program configuration (when remotely monitoring the SAP system installed on a host different from the one on which PFM - Agent for Enterprise Applications is installed)

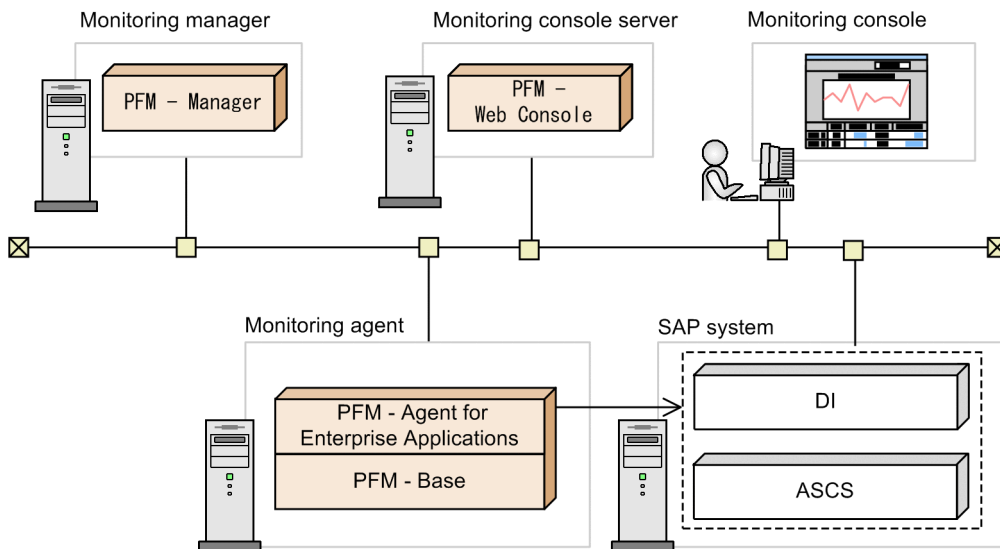

Legend:

- : Program provided by Performance Management
- : Required program
- ASCs : ABAP Central Services instance
- DI : Dialog instance
- : Monitoring

(a) Programs that can be monitored

PFM - Agent for Enterprise Applications can monitor the following program:

- SAP NetWeaver^{#1#2}

This program must be installed on the same host as PFM - Agent for Enterprise Applications.

#1

This program must be installed on only host that contains a central instance with dialog service (primary application server instance) or a dialog instance (additional application server instance).

#2

For details about the versions of SAP NetWeaver, see the *Release Notes*.

(b) Performance Management programs

PFM - Agent and PFM - Base must be installed on the monitoring agent. PFM - Base is a prerequisite program for PFM - Agent. You only need one PFM - Base, even when multiple PFM - Agents and PFM - RMs are installed on the same host.

Note that if you install PFM - Manager and PFM - Agent on the same host, PFM - Base is not required.

If you install PFM - Manager or PFM - Base on a PFM - Agent host, make sure that you install version 12-00. For details about the relationship between hosts on which Performance Management programs are installed and their versions, see the chapter that describes compatibility of versions in a system configuration in the *JPI/Performance Management Planning and Configuration Guide*.

To monitor SAP system operation using PFM - Agent for Enterprise Applications, you need PFM - Manager and PFM - Web Console.

(5) Installing and setting up in a cluster system

The required network environment and program configuration are different for a cluster system than for a normal non-cluster system. In a cluster system, installation and setup are required at both the executing and the standby nodes. For details, see *Chapter 4. Operation in a Cluster System*.

(6) Preparing for data collection in the event of a failure

In the event of a problem, you might need a core dump file to investigate the cause of the problem. Because the creation of a core dump file depends on the user environment settings, check the following settings.

Specifying the core dump file size

The maximum size of a core dump file depends on the superuser's core dump file size setting (`ulimit -c`). Specify the following script:

```
ulimit -c unlimited
```

If this setting violates the security policies of your machine, comment out the script setting as follows:

```
# ulimit -c unlimited
```

! **Important**

If you comment out the script setting, no core dump is output in the event that a process has a segmentation error or a path error, so you might not be able to investigate the cause of error.

3.2.2 Flow of tasks for installation and setup in Linux

This subsection describes the flow of tasks for installing and setting up PFM - Agent for Enterprise Applications.

Figure 3–7: Flow of tasks for installation and setup

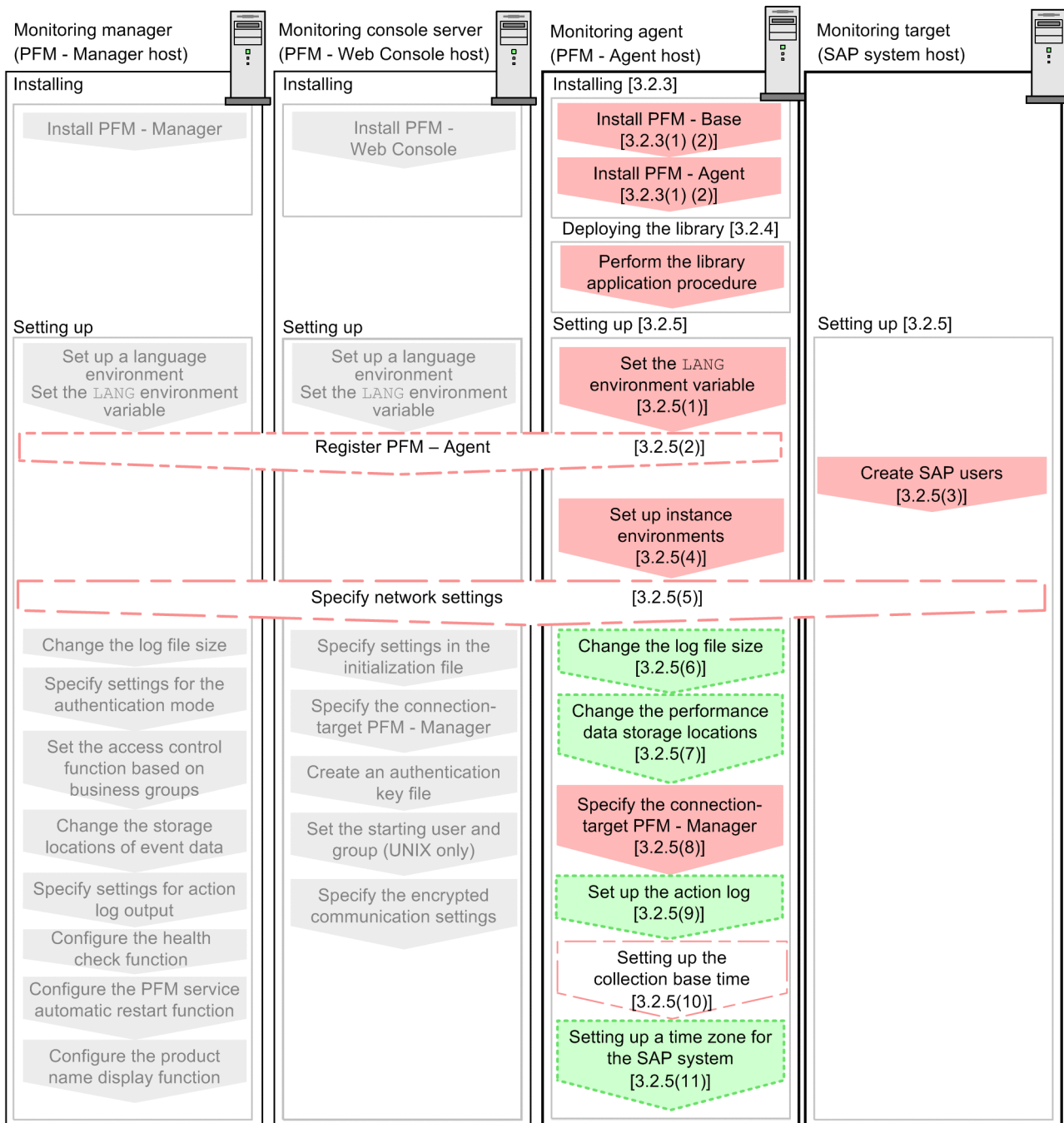

For details about how to install and set up PFM - Manager and PFM - Web Console, see the chapter that describes installation and setup in the *JP1/Performance Management Planning and Configuration Guide*.

3.2.3 Installation procedure in Linux

This subsection describes the program installation order for PFM - Agent for Enterprise Applications and how to install the program from the provided CD-ROM.

(1) Program installation order

You must install PFM - Base before you install a PFM - Agent. PFM - Agent cannot be installed on a host where PFM - Base has not been installed.

To install PFM - Agent and PFM - Manager on the same host, install PFM - Manager first and then PFM - Agent. If you are upgrading the Store database from version 1.0 to 2.0, the setup method depends on the order in which PFM - Agent and PFM - Manager or PFM - Base are installed. For details about how to set up Store version 2.0, see [3.6.2 Updating the Store version to 2.0](#).

Multiple PFM - Agents installed on the same host can be installed in any order.

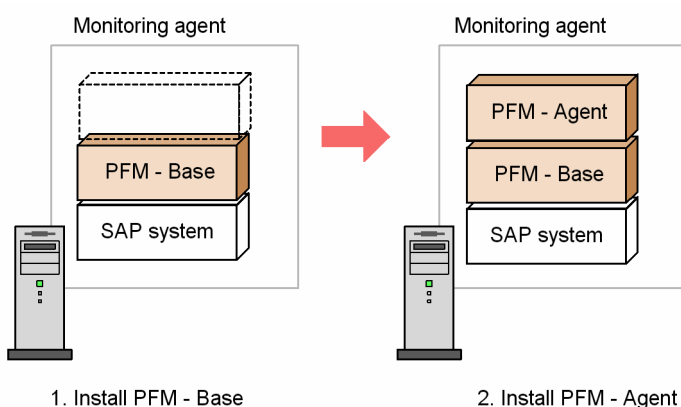

(2) How to install the program

There are two ways to install the Performance Management program on a Linux host. One uses the provided CD-ROM, and the other uses JP1/Software Distribution for remote installation. For details about the method for using JP1/Software Distribution, see the following manuals:

- *Job Management Partner I/Software Distribution Manager Description and Administrator's Guide*
- *Job Management Partner I/Software Distribution SubManager Description and Administrator's Guide*, for UNIX systems
- *Job Management Partner I/Software Distribution Client Description and User's Guide*, for UNIX systems

Note

If Performance Management services are already running on the host where the program is to be installed, you must first stop all the active services, including all services on both physical and logical hosts. For details about stopping services, see the chapter that describes starting and stopping services in the *JP1/Performance Management Planning and Configuration Guide*.

The following subsections describe how to install the program from the provided CD-ROM.

(a) In Linux

1. On the host where the Performance Management program is to be installed, log on as a superuser or use the `su` command to change the user to a superuser.

2. Stop all Performance Management services on the local host.
If any Performance Management services are running, stop all of them.
3. Insert the CD-ROM containing the Performance Management program.
4. Execute the `mount` command to mount the CD-ROM device.

For example, to mount the CD-ROM device on `/cdrom`, execute the command as follows:

```
mount -r -o mode=0544 device-special-file-name /cdrom
```

Note that the command's specification depends on the environment being used.

5. Execute the following command to start the Hitachi Program Product Installer:

```
/cdrom/X64LIN/SETUP /cdrom
```

The Hitachi Program Product Installer starts and displays the initial window.

6. In the initial window, enter `I`.
A list of installable programs is displayed.
7. Select the Performance Management program that you wish to install and then enter `I`.
The selected program is installed. To select a program, move the cursor to the desired program and then select it by pressing the space key.
8. When installation is completed successfully, enter `Q`.
The initial window of the Hitachi Program Product Installer appears again.

Reference

The Performance Management installation directory is created automatically during installation except for PFM - Web Console. The directory specified during the initial installation is assumed during any subsequent installation.

3.2.4 Library application procedure

This section describes how to apply a library.

To use PFM - Agent for Enterprise Applications, the SAP NetWeaver RFC Library provided by SAP must first be installed on the machine where PFM - Agent for Enterprise Applications is installed.

For details about how to obtain and install the SAP NetWeaver RFC Library, see the *Release Notes*.

3.2.5 Setup procedure in Linux

This subsection describes the setup that is required before you can use PFM - Agent for Enterprise Applications.

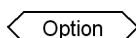
 indicates a setup item whose requirement depends on the environment being used or an optional setup item when you wish to change a default setting.

(1) Specifying the LANG environment variable

The table below shows the LANG environment variable value supported by PFM - Agent for Enterprise Applications.

Before you specify the `LANG` environment variable, make sure that the correct language environment has been installed and constructed. If the language environment is incorrect, encoding errors might occur or definition data might be replaced with invalid data.

Note

The `LANG` environment variable specified at the time of service startup or command execution determines the language used for the common message log. Therefore, character strings in the code sets of multiple languages might coexist.

Table 3–8: LANG environment variable value supported by PFM - Agent for Enterprise Applications

OS	Language		LANG environment variable value
Linux	Japanese	Shift-JIS encoding	ja_JP.SJIS# ja_JP.sjis#
		UTF-8 encoding	ja_JP.UTF-8
	English (no Japanese)		C
	Chinese (simplified)	GB18030	zh_CN.gb18030
		UTF-8	zh_CN.UTF-8 zh_CN.utf8

#: Available only for SUSE Linux

(2) Registering PFM - Agent for Enterprise Applications to PFM - Manager and PFM - Web Console

To use PFM - Manager and PFM - Web Console for centralized management of PFM - Agents, PFM - Agent for Enterprise Applications must be registered into PFM - Manager and PFM - Web Console.

If the version of PFM - Manager is 09-00 or later, PFM - Agent is registered automatically, in which case there is no need to perform the procedure described here. However, any data model version of PFM - Agent that is not included in the *Release Notes* for PFM - Manager must be registered manually. For details about the data model version of PFM - Agent for Enterprise Applications, see [Appendix I. Version Compatibility](#).

The following shows the procedure for registering a PFM - Agent.

Figure 3–8: Procedure for registering a PFM - Agent

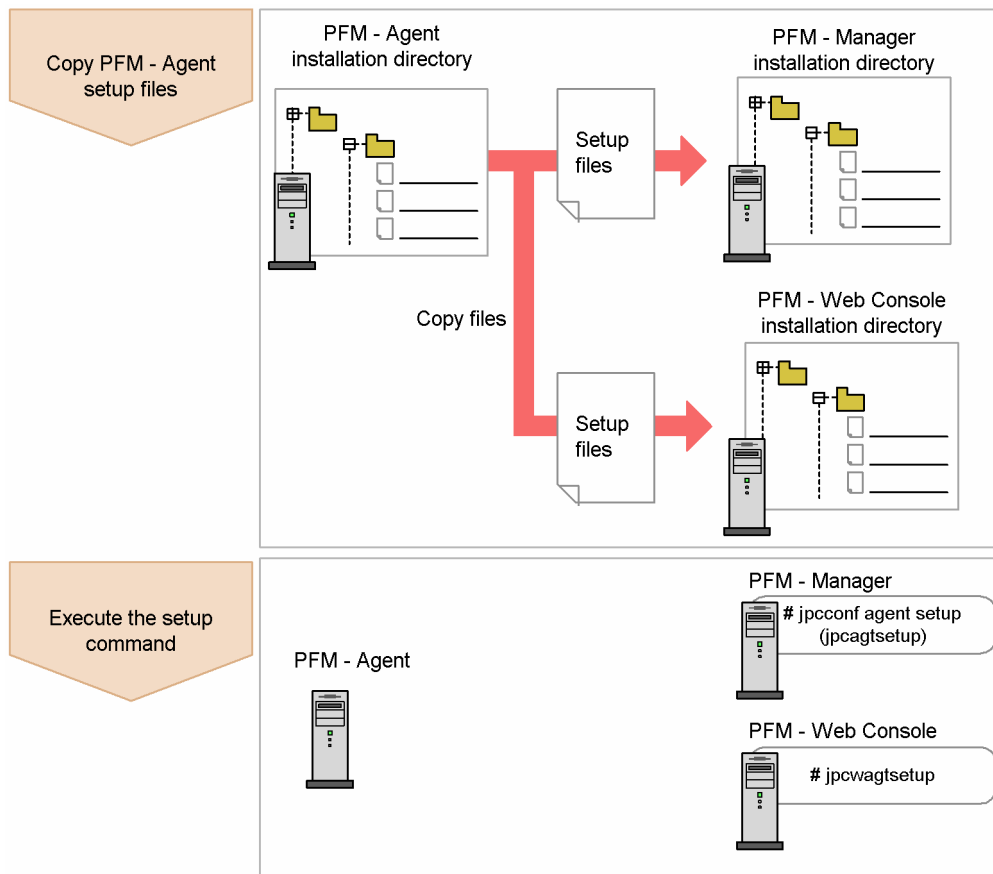

Notes

- Register PFM - Agent before you set up instance environments.
- If you are adding a new version of PFM - Agent for Enterprise Applications to a Performance Management system in which information about PFM - Agent for Enterprise Applications has already been registered, there is no need to register the PFM - Agents.
- If you install a different version of PFM - Agent for Enterprise Applications on a separate host, set up the old version first and then the new version.
- If you have installed PFM - Agent on the same host as PFM - Manager, the `jpcconf agent setup` command executes automatically and the message `KAVE05908-I New agent setup (Pfm-Agent-service-key) ended successfully. (version=version)` is output to the common message log. Check the result; if the command did not execute correctly, re-execute it. For details about executing commands, see the chapter that describes commands in the manual *JPI/Performance Management Reference*.

(a) Copying the setup files for PFM - Agent for Enterprise Applications

Copy the setup files from the host where PFM - Agent for Enterprise Applications was installed to the host where PFM - Manager and PFM - Web Console were installed.

To copy the setup files:

1. Stop PFM - Web Console if it is running.
2. Copy the PFM - Agent setup files in the binary mode.

The table below shows the source and target locations of the files to be copied.

Table 3–9: Setup files to be copied

PFM - Agent setup file	Source		
	PFM program name	OS	Target folder or directory
/opt/jp1pc/setup/jpcagtmw.EXE	PFM - Manager	Windows	<i>PFM-Manager-installation-folder</i> \setup
/opt/jp1pc/setup/jpcagtmu.Z		UNIX	/opt/jp1pc/setup/
/opt/jp1pc/setup/jpcagtmw.EXE	PFM - Web Console	Windows	<i>PFM-Web-Console-installation-folder</i> \setup
/opt/jp1pc/setup/jpcagtmu.Z		UNIX	/opt/jp1pcwebcon/setup/

(b) Executing the setup command at the PFM - Manager host

To use PFM - Manager to set up PFM - Agent for Enterprise Applications, execute the following command:

```
jpccconf agent setup -key EAP
```

Note

An error might occur if the `jpccconf agent setup` command is executed at a local host where Performance Management services have not stopped completely. If an error occurs, check that all Performance Management services have stopped completely and then re-execute the `jpccconf agent setup` command.

After completing this step, you can delete the PFM - Agent setup files from the PFM - Manager host.

(c) Executing the setup command at the PFM - Web Console host

To use PFM - Web Console to set up PFM - Agent for Enterprise Applications, execute the following command:

```
jpcwagtsetup
```

After completing this step, you can delete the PFM - Agent setup files from the PFM - Web Console host.

(3) Creating the SAP users that are to be used by PFM - Agent for Enterprise Applications

To collect performance information, PFM - Agent for Enterprise Applications uses the RFC (communication protocol of SAP AG) to execute the external management interfaces defined in the SAP system. Therefore, you must prepare in advance the SAP system users who are to be used by PFM - Agent for Enterprise Applications.

This subsection describes the user types, passwords, and authorizations for the SAP users who are created in the SAP system.

(a) User types

The following types of SAP users can be used by PFM - Agent for Enterprise Applications:

- Dialog
- System

- Communication
- Service

(b) Characters permitted for passwords

Define passwords for the SAP users. A password can consist of single-byte numeric characters (from 0 to 9), single-byte alphabetic characters (from a to z, A to Z), and the following single-byte symbols:

!, @, \$, %, &, /, (,), =, ?, ', ` , *, +, ~, #, -, _ , ., :, {, [,], }, <, >, |

(c) Required authorizations

You must set the following authorizations (authorization objects) for the users:

- Authorizations required for a user to establish RFC connection with function modules (S_RFC)
- Authorizations required in order to use external management interfaces (S_XMI_PROD)

For the value of each authorization, assign a value shown in the tables below or use the built-in configurations (S_RFC_ALL and S_XMI_ADMIN) that specify an asterisk (*) for all items.

Table 3–10: Authorizations required for a user to establish RFC connection with function modules (S_RFC)

Authorization	Description	Value
RFC_TYPE	Type of RFC object to be protected	FUGR (function group)
RFC_NAME	RFC name to be protected	*
ACTVT	Activity	1 6 (execution)

Table 3–11: Authorizations required in order to use external management interfaces (S_XMI_PROD)

Authorization	Description	Value
EXTCOMPANY	Company name of the external management tool	HITACHI
EXTPRODUCT	Program name of the external management tool	JP1
INTERFACE	Interface ID	*

(4) Setting up instance environments

You must set instance information for each SAP system that is to be monitored by PFM - Agent for Enterprise Applications. You perform the instance information setting at the PFM - Agent host.

The table below lists and describes the instance information items that are to be specified. Check this information before you start the setup procedure. For details about the instance information for an SAP system, see the SAP system documentation.

Table 3–12: Instance information for PFM - Agent for Enterprise Applications

Item	Description	Permitted value	Default value
SID	ID of the SAP system that is to be monitored	Character string (up to 8 bytes)	--

Item	Description	Permitted value	Default value
SERVER ^{#1}	SAP instance name that is to be monitored (the SAP instance name that has a dialog service, and which can be verified by transaction code SM51)	Character string (up to 20 bytes)	Instance name specified in <code>-inst</code> in the <code>jpcconf inst setup</code> command
ASHOST ^{#1}	Host name of the connection-target application server (the SAP local host, which can be verified by transaction code SM51)	Character string (up to 100 bytes)	Local host name
SYSNR	System number of the SAP system	Numeric characters (up to 2 bytes)	00
CLIENT	Client name to which the SAP user belongs (system number assigned to the connection-target dialog instance)	Numeric characters (up to 3 bytes)	000
USER	SAP user name	Character string (up to 12 bytes)	--
EXTPWD	Whether to use an extended password to connect to the SAP system	Y or N <ul style="list-style-type: none"> Y: Use an extended password. N: Do not use an extended password. 	Y
PASSWD	Password of the SAP user	<ul style="list-style-type: none"> When an extended password is used: Up to 40 single-byte characters When an extended password is not used: Up to 8 single-byte characters 	--
DELAYCONNECT	Timing of the connection to the SAP system	Y or N <ul style="list-style-type: none"> Y: Connect to the SAP system only when performance data is collected. The Agent Collector service is started regardless of the operating status of the SAP system at the time of connection establishment. N: Connect to the SAP system when the Agent Collector service starts. The Agent Collector service is not started if the SAP system is not active at the time of connection establishment. 	N
Store Version ^{#2}	Store version to be used. For details about the Store version, see 3.6.2 Updating the Store version to 2.0.	{1.0 2.0}	2.0

Legend:

--: None

#1

To use the remote monitoring function, you have to set both the SAP instance name to be monitored and the host name of the SAP system.

#2

This setting is required when the version of PFM - Agent for Enterprise Applications is 09-00 or later, and the version of PFM - Base or PFM - Manager on the same host is 08-11 or later, and you are setting up an instance environment for the first time.

Note

- If no instance environment has been set up, the PFM - Agent for Enterprise Applications service cannot be started.

You use the `jpcconf inst setup` command to construct an instance environment.

To construct an instance environment:

1. Execute the `jpccconf inst setup` command with the service key and instance name specified.

For example, to construct an instance environment for the instance named `o246bciSD500` for PFM - Agent for Enterprise Applications, execute the following command:

```
jpccconf inst setup -key EAP -inst o246bciSD500
```

Although you can use any instance name in PFM - Agent for Enterprise Applications, to simplify management we recommend that you use an instance name that identifies the SAP system that is to be monitored. Normally, a name in the format *host-name_SAP-system-ID_system-number* is assigned to an instance for an SAP system.

Note that no underscore (`_`) is allowed in the `jpccconf inst setup` command. For example, if the instance name of SAP system is `o246bci_SD5_00`, specify `o246bciSD500` as the instance name of PFM - Agent for Enterprise Applications.

2. Specify instance information for the SAP system.

Enter the information shown in [Table 3-12](#), in accordance with the command's instructions. You cannot omit any requested items. To use a displayed value (which is the default) press the **Enter** key.

Once you have entered all items, the instance environment is constructed. The following describes constructed instance environments:

- Organization of directories for instance environments

Instance environments are configured in the following directories:

- For physical host operation: `/opt/jp1pc/agtm`
- For logical host operation: *environment-directory*#/jp1pc/agtm

#

The environment directory is located on the shared disk that was specified when the logical host was created.

The following table shows the organization of the directories for instance environments.

Table 3–13: Organization of directories for instance environments

Directory and file names		Description	
agent	<i>instance-name</i>	<code>jpccagt.ini</code>	Agent Collector service startup initialization file
		<code>jpccagt.ini.model#</code>	Model file for the Agent Collector service startup initialization file
		<code>jpccMcollect.ini</code>	SAP communications process parameters file
		<code>jr3alget.ini</code>	Environment parameters file for CCMS Alert Monitor Command (PD_ALMX) records
		<code>jr3slget.ini</code>	Environment parameters file for System Log Monitor Command (PD_SLMX) records
		<code>log</code>	Storage directory for log files
store	<i>instance-name</i>	<code>jpccsto.ini</code>	Agent Store service startup initialization file
		<code>jpccsto.ini.model#</code>	Model file for the Agent Store service startup initialization file
		<code>*.DAT</code>	Data model definition file
		<code>dump</code>	Export directory

Directory and file names			Description
store	<i>instance-name</i>	backup	Backup directory
		import	Import directory (for Store version 2.0)
		log	Storage directory for log files
		partial	Partial backup directory (for Store version 2.0)
		STPD	Performance data storage directory for the PD record type (for Store version 2.0)
		STPI	Performance data storage directory for the PI record type (for Store version 2.0)
		STPL	Performance data storage directory for the PL record type (for Store version 2.0)

#

You can use this file to restore the settings that were in effect before the instance environment was constructed.

- Service ID for an instance environment

The service ID for an instance environment is a character string that consists of a product ID, function ID, instance number, instance name, and host name. If the product name is set to display, the service ID would be *instance-name [host-name] program-name*.

For example, service ID `MA1o246bcisD500 [host01]` represents the following instance environment:

- Function ID: A
- Instance number: 1
- Instance name: o246bcisD500
- host name: host01

For details about the service ID, see the appendix in the *JPI/Performance Management Planning and Configuration Guide*.

(5) Specifying network settings Option

You must specify network settings only when you change the network configuration where Performance Management is used.

You can set the following two network settings items:

- IP addresses

Set this information to use Performance Management in a network that is connected to multiple LANs. To set multiple IP addresses, define the host names and IP addresses in the `jpchosts` file. Make sure that the settings in the `jpchosts` file are consistent throughout the entire Performance Management system.

For details, see the chapter that describes installation and setup in the *JPI/Performance Management Planning and Configuration Guide*.

- Port numbers

You can set the port numbers used by Performance Management. To avoid confusion during operation, make sure that the specified port numbers and service names are consistent throughout the entire Performance Management system.

For details about setting port numbers, see the chapter that describes installation and setup in the *JPI/Performance Management Planning and Configuration Guide*.

(6) Changing the log file size Option

Performance Management's operating status is output to a log file unique to Performance Management. This setting is required only when you wish to change this file size.

For details, see the chapter that describes installation and setup in the *JPI/Performance Management Planning and Configuration Guide*.

(7) Changing the performance data storage locations Option

These settings are required only when you wish to change the storage location, backup folder, export folder, partial backup folder, or import folder for the database that stores the performance data managed by PFM - Agent for Enterprise Applications.

The default storage locations for the performance data are as follows:

Storage location	Directory name
Database	/opt/jplpc/agt/store/ <i>instance-name</i> /
Backup	/opt/jplpc/agt/store/ <i>instance-name</i> /backup/
Export	/opt/jplpc/agt/store/ <i>instance-name</i> /dump/
Partial backup (for Store version 2.0)	/opt/jplpc/agt/store/ <i>instance-name</i> /partial/
Import (for Store version 2.0)	/opt/jplpc/agt/store/ <i>instance-name</i> /import/

For details, see [3.6.1 Changing the performance data storage location](#).

(8) Specifying the connection-target PFM - Manager for PFM - Agent for Enterprise Applications

On the host where a PFM - Agent is installed, you must specify the PFM - Manager that manages that PFM - Agent. You use the `jpccconf mgrhost define` command to set the connection-target PFM - Manager.

Notes

- There can be only one PFM - Manager as the connection destination even when multiple PFM - Agents are installed on the same host. Different PFM - Managers cannot be specified for the various PFM - Agents.
- If a PFM - Agent and PFM - Manager are installed on the same host, that PFM - Manager on the local host is automatically the connection-target PFM - Manager; you cannot change the connection-target PFM - Manager to some other PFM - Manager.

To specify the connection-target PFM - Manager:

1. Stop all Performance Management services.

Before you start the setup procedure, you must terminate all Performance Management services that are running on the local host. For details about stopping services, see the chapter that describes starting and stopping services in the *JPI/Performance Management User's Guide*.

If a Performance Management service remains active during execution of the `jpccconf mgrhost define` command, a message is displayed that asks you to terminate the program.

2. Execute the `jpccconf mgrhost define` command with the host name of the connection-target PFM - Manager specified.

For example, if the connection-target PFM - Manager is on host `host01`, specify the command as follows:

```
jpccconf mgrhost define -s host01
```

(9) Setting up the action log Option

You can log information in the action log when, for example, PFM services start and stop, or when the status of the connection to PFM - Manager changes. The action log stores history information that is output in conjunction with the alarms for thresholds related to system load and other conditions.

For details about how to set up the action log, see [Appendix J. Outputting Action Log Data](#).

(10) Setting up the collection base time

To use the remote monitoring function, you have to set the collection base time for the system log information extraction function and the CCMS alert information extraction function. For details about how to set the environment parameters file and the relevant settings, see [5.3 Environment parameters file](#) and [6.3 Environment parameters file](#).

(11) Setting up a time zone for the SAP system Option

To use the remote monitoring function, you have to set a time zone (time difference from UTC) for the SAP system, which will be taken into consideration by the system log information extraction function. For details about how to set the environment parameters file and the relevant settings, see [5.3 Environment parameters file](#) and [6.3 Environment parameters file](#).

3.2.6 Notes about installation and setup in Linux

This subsection provides notes about installing and setting up Performance Management.

(1) Notes about environment variables

Performance Management uses the `JPC_HOSTNAME` environment variable. Do not set a user-specific `JPC_HOSTNAME` environment variable. If such an environment variable is set, Performance Management will not function correctly.

(2) Installing and setting up multiple Performance Management programs on the same host

Performance Management enables you to install PFM - Manager, PFM - Web Console, and PFM - Agent on the same host. This subsection provides notes about such an installation.

- If you install PFM - Manager and PFM - Agent on the same host, there is no need to install PFM - Base. In this case, PFM - Agent requires PFM - Manager; therefore, install PFM - Manager first, and then install PFM - Agent.
- PFM - Base and PFM - Manager cannot be installed on the same host. To install PFM - Manager on a host where PFM - Base and PFM - Agent are already installed, uninstall all Performance Management programs (other than PFM - Web Console), and then install PFM - Manager and PFM - Agent in this order. Similarly, to install PFM - Base on a host where PFM - Manager and PFM - Agent are already installed, uninstall all Performance Management programs (other than PFM - Web Console), and then install PFM - Base and PFM - Agent in this order.
- If you install PFM - Agent on a host where PFM - Manager is already installed, the PFM - Manager on the local host becomes the connection-target PFM - Manager. In such a case, you can no longer change the connection-target

PFM - Manager to a PFM - Manager on a remote host. Therefore, if you want to connect to a PFM - Manager on a remote host, make sure that PFM - Manager has not been installed already on the target host.

- If a PFM - Agent already exists on the host where PFM - Manager is being installed, the local host is redesignated as the connection-target PFM - Manager for that PFM - Agent. The resulting settings are output to the common message log file; check the results.
- If PFM - Web Console already exists on a host where PFM - Agent is to be installed, close all browser windows before starting installation.
- When a new Performance Management program is installed, the default is that the status management function is enabled. However, if you upgrade from version 07-00 to 08-00 or later, the settings for the status management function disabled. To change the status management function settings, see the chapter that describes Performance Management failure detection in the *JPI/Performance Management User's Guide*.

Tip

System performance and reliability are improved by running PFM - Manager, PFM - Web Console, and PFM - Agent on separate hosts.

(3) Upgrading

For details about the precautions to be observed when upgrading from an older version of PFM - Agent, see [Appendix H. Migration Steps and Notes on Migration](#). For details about how to upgrade PFM - Agent, see the relevant appendix in the *JPI/Performance Management Planning and Configuration Guide*.

(4) Notes about the SAP system employing an ASCS instance configuration

To monitor the SAP system, you need to set up an instance environment for each host that contains a central instance with dialog service (primary application server instance) or a dialog instance (additional application server instance).

(5) Notes on using the remote monitoring function

- To use remote monitoring, you have to synchronize the system clocks of different hosts by using NTP or different means.
- If the time zone varies between the host on which PFM - Agent is running and the one on which the monitored SAP system is running, adopt the time zone set for the SAP system by following the steps described in [3.2.5 \(11\) Setting up a time zone for the SAP system](#).

(6) Other notes

- If connection dialogue instance of the SAP system does not have an MTE name for the acquisition, no performance data will be collected from the field of some records because this field does not exist in the connection-target dialog instance. As a result, a warning message (KAVF14173-W) is output to the common message log and Windows event log. This warning message is output regardless of the settings for LOG (whether or not the collected performance data is to be recorded in the Store database) in each record.
- Security monitoring program
Terminate the security monitoring program or change its settings so that installation of the Performance Management programs will not be affected.
- Virus detection program
Terminate any virus detection program before you install the Performance Management programs.

If a virus detection program is running during installation of a Performance Management program, it might slow down the installation process, the installation might fail, or the program might not install correctly.

- **Process monitoring program**
Terminate the process monitoring program or change its settings so that it does not monitor the services and processes of Performance Management or the services and processes of common components.
Installation of a Performance Management program might fail if any of these services or processes is started or stopped by the process monitoring program during the installation process.
- If you are installing PFM - Agent for Enterprise Applications in an environment in which no Performance Management program has been installed, make sure that there are no files or directories in the installation-target directory.
- If installation fails with `Install failed` displayed on the status bar during the installation process, obtain the installation log. It is wise to make a backup of this log file, because it will be overwritten during the next installation. For details about the default file name for the installation log, see [13.4.2\(2\) Information about Performance Management](#).
- If a link is placed in the installation directory to install Performance Management programs, uninstalling all Performance Management programs might not remove all the files and directories from the linked directory. If necessary, manually delete the remaining files and directories. If a Performance Management program is to be installed by linking and the link destination contains a file or directory with the same name, that file or directory will be overwritten when the Performance Management program is installed.

3.3 Uninstallation and unsetup in Windows

This section describes the procedures for uninstalling PFM - Agent for Enterprise Applications and for canceling its setup.

3.3.1 Notes before uninstallation and unsetup in Windows

This section provides notes about uninstalling PFM - Agent for Enterprise Applications and canceling its setup.

(1) OS user permission required for uninstallation

When you uninstall PFM - Agent, make sure that you use an account that has the Administrators permission.

(2) Network

Uninstalling a Performance Management program does not delete port numbers defined in the `services` file.

(3) Programs

- The RFC library stored after installation, as described in [3.1.4 Library application procedure](#), will be deleted at the time of uninstallation. Back it up prior to uninstalling, if necessary.
- If you uninstall PFM - Agent for Enterprise Applications while Performance Management services or other programs that reference Performance Management files (such as Windows Event Viewer) are running, some files and folders might remain in the system. In such a case, a message prompting you to delete everything under `installation-folder\agtm` will be displayed. Manually delete all files and folders under `installation-folder\agtm`.
- If you attempt to uninstall PFM - Agent for Enterprise Applications while Performance Management services or other programs that reference Performance Management files (such as Windows Event Viewer) are running, a message prompting system restart might be displayed. If this occurs, restart the system to complete the uninstallation procedure.
- If PFM - Base and PFM - Agent are both installed on the same host, uninstall PFM - Agent first, and then uninstall PFM - Base. Similarly, if PFM - Manager and PFM - Agent are both installed on the same host, uninstall PFM - Agent first, and then uninstall PFM - Manager.

(4) Services

Uninstalling PFM - Agent does not delete the service information that has been registered in PFM - Manager and that will be displayed when using the `jpctool service list` command. To delete the service information, use the `jpctool service delete` command on the host on which PFM - Manager is installed. To apply the deletion of service information to the PFM - Web Console host, you must execute the `jpctool service sync` command to synchronize the agent information between the PFM - Manager and PFM - Web Console hosts.

(5) Other

- If you uninstall a Performance Management program from a host on which PFM - Web Console has been installed, close all windows on the browser before starting the uninstallation procedure.
- After uninstalling PFM - Agent for Enterprise Applications 11-00 or a later version, if you attempt to install PFM - Agent for Enterprise Applications of a version earlier than 11-00 without uninstalling the PFM - Manager or PFM - Base instance that is on the same device, the required disk space increases about 70 MB compared to the estimated amount required for PFM - Agent for Enterprise Applications of a version earlier than 11-00.

If you want to use a system with the same disk space requirements as those of PFM - Agent for Enterprise Applications of a version earlier than 11-00, uninstall PFM - Base or PFM - Manager, and then install PFM - Agent for Enterprise Applications again.

3.3.2 Unsetup procedure in Windows

This subsection describes how to cancel the setup of PFM - Agent for Enterprise Applications.

(1) Canceling setup of an instance environment

To cancel setup of an instance environment, first verify the instance name and then delete the instance environment. You cancel an instance environment at the PFM - Agent host.

Use the `jpccconf inst list` command to verify the instance name, then use the `jpccconf inst unsetup` command to delete the existing instance environment.

To cancel setup of an instance environment:

1. Find the instance name.

Execute the `jpccconf inst list` command with the service key of PFM - Agent for Enterprise Applications specified.

```
jpccconf inst list -key EAP
```

If the current instance name is `o246bcisd500`, the command displays `o246bcisd500`.

2. If a PFM - Agent service is running in the instance environment, stop the service.

For details about stopping services, see the chapter that describes starting and stopping services in the *JPI/Performance Management User's Guide*.

3. Delete the instance environment.

Execute the `jpccconf inst unsetup` command with the service key and instance name of PFM - Agent for Enterprise Applications specified.

For example, if the existing instance name is `o246bcisd500`, enter the following command:

```
jpccconf inst unsetup -key EAP -inst o246bcisd500
```

If the `jpccconf inst unsetup` command is successful, the folders, service ID, and Windows services created as the instance environment are deleted.

Note

Canceling an instance environment might not delete the service information that is displayed by the `jpctool service list` command. For details about how to delete the service information, see the section on deleting services in the chapter that describes installation and setup in the *JPI/Performance Management Planning and Configuration Guide*.

3.3.3 Uninstallation procedure in Windows

To uninstall PFM - Agent for Enterprise Applications:

1. At the host where PFM - Agent for Enterprise Applications is to be uninstalled, log on as a user with Administrators permission.

2. Stop all Performance Management services at the local host.

Display the service information to make sure that no service is running. For details about stopping services and displaying service information, see the chapter that describes startup and termination of Performance Management in the *JP1/Performance Management User's Guide*.

Stop all Performance Management services that are running at the local host; this includes all services on both physical and logical hosts.

3. Select the Performance Management program to be uninstalled.

From the Windows Control Panel, choose **Programs and Functions**[#], and then select the Performance Management program to be uninstalled

[#]: The displayed name may vary depending on the Windows version.

4. Select **Uninstall** and then choose the **OK** button.

The selected program is uninstalled.

Note

If the OS's user account control (UAC) function is enabled, a user account control dialog box might be displayed during uninstallation. If this dialog box is displayed and you click the **Cancel** or **No** button, uninstallation will be canceled. If you wish to continue the uninstallation process, click the **Continue** or **Yes** button.

3.4 Uninstallation and unsetup in Linux

This section describes the procedures for uninstalling PFM - Agent for Enterprise Applications and for canceling its setup.

3.4.1 Notes before uninstallation and unsetup in Linux

This section provides notes about uninstalling PFM - Agent for Enterprise Applications and canceling its setup.

(1) OS user permission required for uninstallation

When you uninstall PFM - Agent, make sure that you use an account that has the superuser permission.

(2) Network

Uninstalling a Performance Management program does not delete port numbers defined in the `services` file.

(3) Programs

- The RFC library stored after installation, as described in [3.2.4 Library application procedure](#), will be deleted at the time of uninstallation. Back it up prior to uninstalling, if necessary.
- If PFM - Base and PFM - Agent are both installed on the same host, uninstall PFM - Agent first, and then uninstall PFM - Base. Similarly, if PFM - Manager and PFM - Agent are both installed on the same host, uninstall PFM - Agent first, and then uninstall PFM - Manager.

(4) Notes about services

Uninstalling PFM - Agent does not delete the service information that has been registered in PFM - Manager and that will be displayed when using the `jpctool service list` command. To delete the service information, use the `jpctool service delete` command on the host on which PFM - Manager is installed. To apply the deletion of service information to the PFM - Web Console host, you must execute the `jpctool service sync` command to synchronize the agent information between the PFM - Manager and PFM - Web Console hosts.

(5) Other

If you uninstall a Performance Management program from a host on which PFM - Web Console has been installed, close all windows on the browser before starting the uninstallation procedure.

3.4.2 Unsetup procedure in Linux

This subsection describes how to cancel the setup of PFM - Agent for Enterprise Applications.

(1) Canceling setup of an instance environment

To cancel setup of an instance environment, first verify the instance name and then delete the instance environment. You cancel an instance environment at the PFM - Agent host.

Use the `jpccconf inst list` command to verify the instance name, and then use the `jpccconf inst unsetup` command to delete the existing instance environment.

To cancel setup of an instance environment:

1. Find the instance name.

Execute the `jpccconf inst list` command with the service key of PFM - Agent for Enterprise Applications specified.

```
jpccconf inst list -key EAP
```

If the current instance name is `o246bcisd500`, the command displays `o246bcisd500`.

2. If a PFM - Agent service is running in the instance environment, stop the service.

For details about stopping services, see the chapter that describes starting and stopping services in the *JPI/Performance Management User's Guide*.

3. Delete the instance environment.

Execute the `jpccconf inst unsetup` command with the service key and instance name of PFM - Agent for Enterprise Applications specified.

For example, if the existing instance name is `o246bcisd500`, enter the following command:

```
jpccconf inst unsetup -key EAP-inst o246bcisd500
```

If the `jpccconf inst unsetup` command is successful, the folders, service ID, and Windows services created as the instance environment are deleted.

Note

Canceling an instance environment might not delete the service information that is displayed by the `jpctool service list` command. For details about how to delete the service information, see the section on deleting services in the chapter that describes installation and setup in the *JPI/Performance Management Planning and Configuration Guide*.

3.4.3 Uninstallation procedure in Linux

To uninstall PFM - Agent for Enterprise Applications:

1. At the host where PFM - Agent for Enterprise Applications is to be uninstalled, log on as a superuser or use the `su` command to change the user to a superuser.

2. Stop all Performance Management services at the local host.

Display the service information to make sure that no service is running. For details about stopping services and displaying service information, see the chapter that describes startup and termination of Performance Management in the *JPI/Performance Management User's Guide*.

Stop all Performance Management services that are running at the local host; this includes all services on both physical and logical hosts.

3. Execute the following command to start the Hitachi Program Product Installer:

```
/etc/hitachi_x64setup
```

The Hitachi Program Product Installer starts and displays the initial window.

4. In the initial window, enter D.

A list of programs that can be uninstalled is displayed.

5. Select the Performance Management program that you wish to uninstall and then enter D.

The selected program is uninstalled. To select a program, move the cursor to the desired program and then select it by pressing the space key.

6. When uninstallation is completed successfully, enter Q.

The initial window of the Hitachi Program Product Installer appears again.

3.5 Changing the PFM - Agent for Enterprise Applications system configuration

You must change the system configuration for PFM - Agent for Enterprise Applications whenever a change occurs in the system, such as a change in a monitored system's network configuration or a change in host names. This subsection describes how to change the system configuration for PFM - Agent for Enterprise Applications.

- If you change a host name in the SAP system

Change the following item in the setup procedure for updating the instance environment:

- ASHOST

If you change any item that was entered during the instance environment setup procedure in the SAP system, use the setup procedure for updating the instance environment to update the information that was changed.

- If you change the system configuration for PFM - Agent for Enterprise Applications

You must also change the settings for PFM - Manager and PFM - Web Console. For details about how to change the system configuration for Performance Management, see the chapter that describes installation and setup in the *JPI/Performance Management Planning and Configuration Guide*.

- If you change the time zone set for the SAP system (except when this change is necessitated by the switch between standard time and daylight saving time)

To extract system log information from the SAP system in which daylight saving time had been applied to the time zone before the change of the time zone setting, you have to edit the `SAPTIMEZONEOFFSET` setting during the switch between standard time and daylight saving time.



Tip

As daylight saving time is switched to standard time, a two-hour overlap period arises, which corresponds to the last one hour of daylight saving time plus the first one hour of standard time. With the SAP system, it is recommended that the system be shut down during this period. For example, when daylight saving time is switched to standard time, a one-hour period from 2:00 a.m. to 3:00 a.m. may be repeated twice. In this case, you have to disable the system during the period from 1:55 a.m. to 3:05 a.m. For details about how to operate the SAP system during the switch from daylight saving time to standard time, see *SAP Notes 7417* and *102088*.

You can edit the `SAPTIMEZONEOFFSET` setting in an environment where daylight saving time is adopted as follows:

Switching from standard time to daylight saving time

1. Shut down PFM - Agent for Enterprise Applications before daylight saving time begins.
2. Edit the `SAPTIMEZONEOFFSET` value in the environment parameters file to reflect daylight saving time.
3. After daylight saving time begins, start PFM - Agent for Enterprise Applications.

Switching from daylight saving time to standard time

1. Shut down PFM - Agent for Enterprise Applications one hour before standard time begins.
2. Edit the `SAPTIMEZONEOFFSET` value in the environment parameters file to reflect standard time.
3. At least one hour after standard time begins, start PFM - Agent for Enterprise Applications.

3.6 Changing the PFM - Agent for Enterprise Applications operation method

It might be necessary to change the operating method for PFM - Agent for Enterprise Applications for a reason such as a change in the method of handling the collected operation monitoring data. This section describes how to change the operating method for PFM - Agent for Enterprise Applications. For details about how to change the operating method for the overall Performance Management system, see the chapter that describes installation and setup in the *JPI/Performance Management Planning and Configuration Guide*.

3.6.1 Changing the performance data storage location

The performance data collected by PFM - Agent for Enterprise Applications is managed in the Store database of the Agent Store service of PFM - Agent for Enterprise Applications. This subsection describes how to change the storage location of performance data.

(1) Using the `jpccconf db define (jpcdbctrl config)` command to change settings

To change the data storage folders listed below for the performance data that is to be managed in the Store database, use the `jpccconf db define` command. If you wish to save the performance data already in the Store database storage folder prior to the change, use the `-move` option of the `jpccconf db define` command. For details about the `jpccconf db define` command, see the manual *JPI/Performance Management Reference*.

- Storage folder
- Backup folder
- Export folder
- Partial backup folder[#]
- Import folder[#]

[#]: Supported only when Store version 2.0 is used.

The following table lists and describes the information that can be set by the `jpccconf db define` command, such as option names and value ranges.

Table 3–14: Command settings for changing the performance data storage location

Description	Host environment	Option name	Permitted value (Store version 1.0)	Permitted value (Store version 2.0)	Default value
Performance data creation folder	Physical host	<code>sd</code>	1 to 127 bytes of full path name	1 to 214 bytes of full path name ^{#1}	<ul style="list-style-type: none">• In Windows <i>installation-folder\agtm\store\instance-name</i>• In Linux <i>/opt/jp1pc/agtm/store/instance-name</i>
	Logical host	<code>sd</code>	1 to 127 bytes of full path name	1 to 214 bytes of full path name ^{#1}	<ul style="list-style-type: none">• In Windows <i>environment-directory^{#2}\jp1pc\agtm\store\instance-name</i>

Description	Host environment	Option name	Permitted value (Store version 1.0)	Permitted value (Store version 2.0)	Default value
Performance data creation folder	Logical host	sd	1 to 127 bytes of full path name	1 to 214 bytes of full path name ^{#1}	<ul style="list-style-type: none"> In Linux <i>environment-directory</i>^{#2}/<i>jp1pc/agtm/store/instance-name</i>
Performance data backup folder (full backup)	Physical host	bd	1 to 127 bytes of full path name	1 to 211 bytes of full path name ^{#3}	<ul style="list-style-type: none"> In Windows <i>installation-folder\agtm\store\instance-name\backup</i> In Linux <i>/opt/jp1pc/agtm/store/instance-name/backup</i>
	Logical host	bd	1 to 127 bytes of full path name	1 to 211 bytes of full path name ^{#3}	<ul style="list-style-type: none"> In Windows <i>environment-directory</i>^{#2}\jp1pc\agtm\store\instance-name\backup In Linux <i>environment-directory</i>^{#2}/<i>jp1pc/agtm/store/instance-name/backup</i>
Performance data backup folder (partial backup)	Physical host	pbd	--	1 to 214 bytes of full path name ^{#1}	<ul style="list-style-type: none"> In Windows <i>installation-folder\agtm\store\instance-name\partial</i> In Linux <i>/opt/jp1pc/agtm/store/instance-name/partial</i>
	Logical host	pbd	--	1 to 214 bytes of full path name ^{#1}	<ul style="list-style-type: none"> In Windows <i>environment-directory</i>^{#2}\jp1pc\agtm\store\instance-name\partial In Linux <i>environment-directory</i>^{#2}/<i>jp1pc/agtm/store/instance-name/partial</i>
Maximum generation number when performance data is backed up		bs	1 to 9	1 to 9	5
Performance data export folder	Physical host	dd	1 to 127 bytes of full path name	1 to 127 bytes of full path name	<ul style="list-style-type: none"> In Windows <i>installation-folder\agtm\store\instance-name\dump</i> In Linux <i>/opt/jp1pc/agtm/store/instance-name/dump</i>
	Logical host	dd	1 to 127 bytes of full path name	1 to 127 bytes of full path name	<ul style="list-style-type: none"> In Windows <i>environment-directory</i>^{#2}\jp1pc\agtm\store\instance-name\dump In Linux <i>environment-directory</i>^{#2}/<i>jp1pc/agtm/store/instance-name/dump</i>

Description	Host environment	Option name	Permitted value (Store version 1.0)	Permitted value (Store version 2.0)	Default value
Performance data import folder	Physical host	id	--	1 to 222 bytes of full path name ^{#4}	<ul style="list-style-type: none"> In Windows <i>installation-folder\agtm\store\instance-name\import</i> In Linux <i>/opt/jp1pc/agtm/store/instance-name/import</i>
	Logical host	id	--	1 to 222 bytes of full path name ^{#4}	<ul style="list-style-type: none"> In Windows <i>environment-directory#2\jp1pc\agtm\store\instance-name\import</i> In Linux <i>environment-directory#2/jp1pc/agtm/store/instance-name/import</i>

Legend:

--: Cannot be set

#1

If a relative path is set, the length of the specified folder path (absolute path) must not exceed 214 bytes.

#2

The environment directory is located on the shared disk that was specified when the logical host was created.

#3

If a relative path is set, the length of the specified folder path (absolute path) must not exceed 211 bytes.

#4

If a relative path is set, the length of the specified folder path (absolute path) must not exceed 222 bytes.

(2) Editing the jpcsto.ini file to change settings (for Store version 1.0 only)

If you are using Store version 1.0, you can directly edit `jpcsto.ini`.

(a) Settings in the jpcsto.ini file

The table below shows the settings in the `jpcsto.ini` file, such as the label names that can be edited and the permitted value ranges.

Table 3–15: Settings for the performance data storage location ([Data Section] section in `jpcsto.ini`)

Description	Host environment	Label name	Permitted value (Store version 1.0) ^{#1}	Default value
Performance data creation folder	Physical host	Store Dir ^{#2}	1 to 127 bytes of full path name	<ul style="list-style-type: none"> In Windows <i>installation-folder\agtm\store\instance-name</i> In Linux <i>/opt/jp1pc/agtm/store/instance-name</i>
	Logical host	Store Dir ^{#2}	1 to 127 bytes of full path name	<ul style="list-style-type: none"> In Windows <i>environment-directory#3\jp1pc\agtm\store\instance-name</i>

Description	Host environment	Label name	Permitted value (Store version 1.0)#1	Default value
Performance data creation folder	Logical host	Store Dir#2	1 to 127 bytes of full path name	<ul style="list-style-type: none"> In Linux <i>environment-directory</i>#3/jp1pc/agt/store/<i>instance-name</i>
Performance data backup folder (full backup)	Physical host	Backup Dir#2	1 to 127 bytes of full path name	<ul style="list-style-type: none"> In Windows <i>installation-folder</i>\agt\store\<i>instance-name</i>\backup In Linux /opt/jp1pc/agt/store/<i>instance-name</i>/backup
	Logical host	Backup Dir#2	1 to 127 bytes of full path name	<ul style="list-style-type: none"> In Windows <i>environment-directory</i>#3\jp1pc\agt\store\<i>instance-name</i>\backup In Linux <i>environment-directory</i>#3/jp1pc/agt/store/<i>instance-name</i>/backup
Maximum generation number when performance data is backed up		Backup Save	1 to 9	5
Performance data export folder	Physical host	Dump Dir#2	1 to 127 bytes of full path name	<ul style="list-style-type: none"> In Windows <i>installation-folder</i>\agt\store\<i>instance-name</i>\dump In Linux /opt/jp1pc/agt/store/<i>instance-name</i>/dump
	Logical host	Dump Dir#2	1 to 127 bytes of full path name	<ul style="list-style-type: none"> In Windows <i>environment-directory</i>#3\jp1pc\agt\store\<i>instance-name</i>\dump In Linux <i>environment-directory</i>#3/jp1pc/agt/store/<i>instance-name</i>/dump

#1

- Specify all folder names as full path names.
- All alphanumeric characters, symbols, and the space are permitted, except for the following characters:
; , ! , * , ? , ' , " , < , > , |
- If a specified value is invalid, the Agent Store service cannot be started.

#2

No duplication of folder names can be specified in Store Dir, Backup Dir, and Dump Dir.

#3

The environment directory is located on the shared disk that was specified when the logical host was created.

(b) Preparations before editing the jpcsto.ini file

- In order to change the Store database storage folder, you must first create the storage folder that is to be used.
- Once you have changed the Store database storage folder, the performance data that was collected previously is no longer available. If you need the previous performance data, the following procedure can be used to inherit it:

3.6.2 Updating the Store version to 2.0

The two types of Store database storage formats are versions 1.0 and 2.0. For details about Store version 2.0, see the *JPI/Performance Management Planning and Configuration Guide*.

Store version 2.0 is used by default only when you have configured a new instance in an environment of PFM - Base or PFM - Manager version 08-11 or later using PFM - Agent for Enterprise Applications version 09-00 or later. Otherwise, the Store version 1.0 format is used, and you will have to use the setup command to update the Store version to 2.0.

If you need to restore Store version 1.0 for some reason, cancel the setup of Store version 2.0.

The following table shows whether Store version 2.0 is supported, depending on the installation conditions, and describes the operating procedure.

Table 3–16: Whether Store version 2.0 is supported and the operating procedure

Installation condition		Whether Store version 2.0 is supported	Store version 2.0 operating procedure
Version of the installed PFM - Base or PFM - Manager	PFM - Agent installation method		
08-00 or earlier	Overwrite installation	Not supported	Upgrade PFM - Base or PFM - Manager to version 08-11 and then execute the setup command.
	New installation		
08-11 or later	Overwrite installation	An existing instance is supported after setup	Execute the setup command.
		A new instance is supported	Use the <code>jpccconf inst setup</code> command to set up when the instance is configured.
	New installation	Supported	Use the <code>jpccconf inst setup</code> command to set up when the instance is configured.

(1) Setting up Store version 2.0

This subsection describes how to set up Store version 2.0 when you update the Store database.

1. Estimating the system resources and setting the retention period

Make sure that the system resources required for installing Store version 2.0 are appropriate for the execution environment. The types of required system resources are as follows:

- Disk capacity
- Number of files
- Number of files opened by each process

Use retention period settings to adjust these values. Set the retention period taking into account the resources available in the execution environment. For details about estimating the system resources, see the *Release Notes* for PFM - Agent for Enterprise Applications.

2. Setting folders

After you have updated your Store database to Store version 2.0, the Agent Store service might not start using the data storage folder settings for performance data that were set for Store version 1.0. For this reason, you must specify the folder settings again. For details, see [3.6.1 Changing the performance data storage location](#).

3. Executing the setup command

To update the Store version to 2.0, execute the `jpccconf db vrset -ver 2.0` command. You must execute this command for each Agent instance.

For details about the `jpccconf db vrset -ver 2.0` command, see the manual *JPI/Performance Management Reference*.

4. Setting the retention period

Set the retention period that was determined during the estimation process in step 1. Start the Agent Store service and use PFM - Web Console to specify the settings.

(2) Canceling the setup of Store version 2.0

To cancel the setup of Store version 2.0, use the `jpccconf db vrset -ver 1.0` command. When the setup of Store version 2.0 is canceled, all data in the Store database is initialized and the Store database is reset to Store version 1.0.

For details about the `jpccconf db vrset -ver 1.0` command, see the manual *JPI/Performance Management Reference*.

(3) Notes

This subsection provides notes about updating.

(a) When updating from Store version 1.0 to Store version 2.0

When the Store database is updated from Store version 1.0 to 2.0, the retention period settings are inherited for records of the PI record type. However, for records of the PD record type, the default retention days value (which determines the number of records to be retained) is set to the default value for each record regardless of the previous settings, and the data that had been collected prior to the default retention days value is deleted.

For example, if 1,000 PD records whose Collection Interval is 3,600 seconds are set to be retained in Store version 1.0, about 42 days (1,000/24) worth of data is stored because 24 PD records are stored per day. If this Store database is updated to Store version 2.0 and the value 10 had been set as the default retention days value for PD records, the data obtained more than 10 days ago will be deleted and will no longer be viewable.

Before you update the Store database to Store version 2.0, check the settings for the number of records to be retained for the PD record type. If more than the default retention days worth of data is set to be retained in Store version 2.0, use the `jpctool db dump` command to output the data from the database. For details about the default retention days in Store version 2.0, see the *Release Notes* for PFM - Agent for Enterprise Applications.

(b) When restoring Store version 1.0 from 2.0

If you cancel the setup of Store version 2.0, the data is initialized. Therefore, before you restore Store version 1.0, execute the `jpctool db dump` command to output the Store version 2.0 information.

(c) Default record retention period in Store version 2.0

Store version 2.0 is supported when PFM - Manager or PFM - Base version 08-11 or later is combined with PFM - Agent for Enterprise Applications version 08-00 or later. The default record retention period depends on whether PFM - Agent for Enterprise Applications 09-00 or later is used or PFM - Agent for Enterprise Applications 08-00 is used.

If PFM - Agent for Enterprise Applications 09-00 or later is used:

For details about the default record retention period, see the *Release Notes* for PFM - Agent for Enterprise Applications.

If PFM - Agent for Enterprise Applications 08-00 is used:

The default retention period is set to 10 days for all records of the PD and PL record types. For records of the PI record type, the default retention period is set as shown in the table below.

Table 3–17: Default retention period for records of the PI record type

Retention period before setup	Retention period after setup				
	Summary type				
	By the minute (in days)	Hourly (in days)	Daily (in weeks)	Weekly (in weeks)	Monthly (in months)
1 minute	1	--	--	--	--
1 hour	1	1	--	--	--
1 day	1	1	1	--	--
2 days	2	2	1	--	--
3 days	3	3	1	--	--
4 days	4	4	1	--	--
5 days	5	5	1	--	--
6 days	6	6	1	--	--
1 week	7	7	1	1	--
1 month	31	31	5	5	1
1 year	366	366	54	54	12

Legend:

--: Cannot be specified

3.6.3 Settings for updating an instance environment

This subsection describes how to update an instance environment.

You must repeat this procedure for each instance environment you wish to update.

Use the `jpccconf inst list` command to find the instance name; use the `jpccconf inst setup` command to update the instance environment.

To update an instance environment:

1. Find the instance name.

Execute the `jpccconf inst list` command with the service key specified that indicates the PFM - Agent for Enterprise Applications running in the instance environment.

For example, to check the instance name of PFM - Agent for Enterprise Applications, execute the following command:

```
jpccconf inst list -key EAP
```

If the specified instance name is `o246bcisd500`, the command displays `o246bcisd500`.

2. Check the information to be updated.

The following table lists and describes the instance environment information that can be updated.

Table 3–18: Instance information for PFM - Agent for Enterprise Applications

Item	Description	Permitted value	Default value
SID	ID of the SAP system that is to be monitored	Character string (up to 8 bytes)	Previous setting
SERVER#1	SAP instance name that is to be monitored (the SAP instance name that has a dialog service, and which can be verified by transaction code SM51)	Character string (up to 20 bytes)	Previous setting
ASHOST#1	Host name of the connection-target application server (the SAP local host name, which can be verified by transaction code SM51)	Character string (up to 100 bytes)	Previous setting
SYSNR	System number of the SAP system	Numeric characters (up to 2 bytes)	Previous setting
CLIENT	Client name to which the SAP user belongs (system number assigned to the connection-target dialog instance)	Numeric characters (up to 3 bytes)	Previous setting
USER	SAP user name#2	Character string (up to 12 bytes)	Previous setting
EXTPWD	Whether an extended password is to be used to connect to the SAP system	Y or N <ul style="list-style-type: none"> Y: Use an extended password. N: Do not use an extended password. 	Previous setting
PASSWD	Password of the SAP user#2	<ul style="list-style-type: none"> When an extended password is used: Up to 40 single-byte characters When an extended password is not used: Up to 8 single-byte characters 	Previous setting (the value is not displayed)
DELAYCONNE CT	Timing of the connection to the SAP system	Y or N: <ul style="list-style-type: none"> Y: Connect to the SAP system only when performance data is collected. The Agent Collector service is started regardless of the operating status of the SAP system at the time of connection establishment. N: Connect to the SAP system when the Agent Collector service starts. The Agent Collector service is not started if the SAP system is not active at the time of connection establishment. 	Previous setting

#1

To use the remote monitoring function, you have to set both the SAP instance name to be monitored and the host name of the SAP system.

#2

For details about SAP users and passwords, see [3.1.5\(2\) Creating SAP users that are to be used by PFM - Agent for Enterprise Applications](#).

3. If the PFM - Agent for Enterprise Applications service is active for the instance environment that is to be updated, stop it.

If the service is still active for the instance environment that is to be updated when you execute the `jpccconf inst setup` command, a confirmation message is displayed to enable you to stop the service. If you stop the service, update processing resumes; if you do not stop the service, update processing is canceled.

- Execute the `jpccconf inst setup` command, in which you have specified the service key and instance name of the PFM - Agent for Enterprise Applications for the instance environment that you wish to update.

For example, if you are updating the instance environment for the PFM - Agent for Enterprise Applications with instance name `o246bciSD500`, execute the command as follows:

```
jpccconf inst setup -key EAP -inst o246bciSD500
```

Although you can use any instance name in PFM - Agent for Enterprise Applications, to simplify management we recommend that you use an instance name that identifies the SAP system that is to be monitored. Normally, a name in the format *host-name_SAP-system-ID_system-number* is assigned to an instance for an SAP system.

Note that no underscore (`_`) is allowed in the `jpccconf inst setup` command. For example, if the instance name of SAP system is `o246bci_SD5_00`, specify `o246bciSD500` as the instance name of PFM - Agent for Enterprise Applications.

- Update the instance information for SAP system.

Enter the information shown in [Table 3-18](#) in accordance with the command's instructions. The current settings are displayed (except for the value of `passwd`). To use a displayed value, press the **Enter** key. When all entries are completed, the instance environment is updated.

- Restart the services in the updated instance environment.

For details on how to start and stop services, see the chapter that describes starting and stopping services in the *JPI/Performance Management User's Guide*. For details about the commands, see the chapter that describes commands in the manual *JPI/Performance Management Reference*.

3.7 Backing up and restoring PFM - Agent for Enterprise Applications

This section describes backing up and restoring PFM - Agent for Enterprise Applications.

To protect against damage to the system caused by a failure, we recommend that you periodically back up the settings for PFM - Agent for Enterprise Applications. We recommend that you also back up the settings whenever a change has been made to the system, such as when PFM - Agent for Enterprise Applications is set up.

For details about backing up and restoring the entire Performance Management system, see the chapter that describes backup and restoration in the *JPI/Performance Management User's Guide*.

3.7.1 Backup

You can make a backup using any method, such as by copying files. Perform the backup operation while the services of PFM - Agent for Enterprise Applications are stopped.

The following table lists the settings files for PFM - Agent for Enterprise Applications that must be included in a backup.

Table 3–19: Files to be backed up for PFM - Agent for Enterprise Applications

Description	Host environment	File name
Settings file for the Agent Collector service	Physical host	<ul style="list-style-type: none"> In Windows <i>installation-folder</i>\agtm\agent*.ini In Linux /opt/jp1pc/agtm/agent/*.ini
	Logical host	<ul style="list-style-type: none"> In Windows <i>environment-directory</i>\jp1pc\agtm\agent*.ini In Linux <i>environment-directory</i>/jp1pc/agtm/agent/*.ini
Settings file for the Agent Store service	Physical host	<ul style="list-style-type: none"> In Windows <i>installation-folder</i>\agtm\store*.ini In Linux /opt/jp1pc/agtm/store/*.ini
	Logical host	<ul style="list-style-type: none"> In Windows <i>environment-directory</i>\jp1pc\agtm\store*.ini In Linux <i>environment-directory</i>/jp1pc/agtm/store/*.ini
Environment parameters file for the system log	Physical host	<ul style="list-style-type: none"> In Windows <i>installation-folder</i>\agtm\agent\jr3slget.ini (default) In Linux /opt/jp1pc/agtm/agent/jr3slget.ini (default) <p>The file path is the current directory for command execution or the file path specified in the <code>-cnf</code> option.</p>
	Logical host	<ul style="list-style-type: none"> In Windows <i>environment-directory</i>\jp1pc\agtm\agent\jr3slget.ini (default) In Linux

Description	Host environment	File name
Environment parameters file for the system log	Logical host	<p><i>environment-directory</i>/jplpc/agtm/agent/jr3slget.ini (default)</p> <p>The file path is the current directory for command execution or the file path specified in the <code>-cnf</code> option.</p>
Environment parameters file for CCMS alerts	Physical host	<ul style="list-style-type: none"> In Windows <i>installation-folder</i>\agtm\agent\jr3alget.ini (default) In Linux /opt/jplpc/agtm/agent/jr3alget.ini (default) <p>The file path is the current directory for command execution or the file path specified in the <code>-cnf</code> option.</p>
	Logical host	<ul style="list-style-type: none"> In Windows <i>environment-directory</i>\jplpc\agtm\agent\jr3alget.ini (default) In Linux <i>environment-directory</i>/jplpc/agtm/agent/jr3alget.ini (default) <p>The file path is the current directory for command execution or the file path specified in the <code>-cnf</code> option.</p>

Important

When you back up PFM - Agent for Enterprise Applications, you must manage the environment's product version numbers. For details about product versions, see the *Release Notes* for PFM - Agent for Enterprise Applications.

3.7.2 Restoration

To restore the settings for PFM - Agent for Enterprise Applications, make sure that the prerequisites listed below are satisfied and then copy the backup files to their original locations. The settings files on the host will be overwritten by the contents of the backup settings files.

(1) Prerequisites

- PFM - Agent for Enterprise Applications has already been installed.
- All services of PFM - Agent for Enterprise Applications have stopped.
- The instance environment for PFM - Agent for Enterprise Applications that was set up at the time of the backup has already been set up.

(2) Notes about restoration

- To restore the settings for PFM - Agent for Enterprise Applications, the product version numbers must match between the environment from which the backup was acquired and the environment in which the backup is restored. For details about product versions, see the *Release Notes* for PFM - Agent for Enterprise Applications. The following examples show when the settings for PFM - Agent for Enterprise Applications can and cannot be restored.

Example of when PFM - Agent for Enterprise Applications settings can be restored.

The settings backed up by PFM - Agent for Enterprise Applications 09-00 are restored to PFM - Agent for Enterprise Applications 09-00.

Examples of when PFM - Agent for Enterprise Applications settings cannot be restored:

- The settings backed up by PFM - Agent for Enterprise Applications 08-00 are restored to PFM - Agent for Enterprise Applications 09-00.
- The settings backed up by PFM - Agent for Enterprise Applications 09-00 are restored to PFM - Agent for Enterprise Applications 09-00-04.
- After the settings have been restored, the SAP system's system logs and CCMS alerts might not be output correctly. After you have restored the settings, manually delete the target files from the following directories:

Target directories

- In Windows (physical host environment):
installation-folder\agtm\agent\instance-name\log
- In Windows (logical host environment):
environment-directory\jplpc\agtm\agent\instance-name\log
- In Linux (physical host environment):
/opt/jplpc/agtm/agent/instance-name/log
- In Linux (logical host environment):
environment-directory/jplpc/agtm/agent/instance-name/log
- Command execution:
Directory specified in the WORKDIR label in the COMMAND section in the environment parameter file

Target files

- Timestamp file (default: jr3slget.lasttime or jr3alget.lasttime)
- System log information storage file (default: SYSLOG or SYSLOG $n^{\#}$)
- CCMS Alert Information storage file (default: ALERT or ALERT $n^{\#}$)
- Management file (default: SYSLOG.ofs or ALERT.ofs)

 n indicates a value from one through the value specified in the NUM label in the EXTRACTFILE section in the environment parameter file.

3.8 Settings for using a Web browser to reference manuals

You can copy the Performance Management manuals from the manual distribution media provided with the program product to the host where PFM - Web Console is installed. You can then use a Web browser to reference the manuals. If you are running PFM - Web Console in a cluster environment, copy the manuals onto the physical hosts of both executing and standby systems.

3.8.1 Setup procedure for referencing manuals

(1) When referencing manuals from Help of PFM - Web Console

1. Register PFM - Agent into PFM - Web Console according to the PFM - Web Console setup procedure (perform additional setup of PFM - Agent).
2. On the host where PFM - Web Console is installed, create a directory into which you can copy manuals:
You need to create the following directory:

In Windows:

PFM - Web Console-installation-folder\doc\en\help-ID-of-PFM - Agent for Enterprise Applications

In Linux:

/opt/jp1pcwebcon/doc/en/help-ID-of-PFM - Agent for Enterprise Applications

For details about the help ID of PFM - Agent for Enterprise Applications, see [Appendix C. List of Identifiers](#).

3. Copy the following files and directories from the manual distribution media in to the directory you created in step 2:

For HTML manuals

In Windows:

All HTML and CSS files and GRAPHICS folders under *CD-ROM-drive/MAN/3021/manual-number* (such as 03004A0D)

In Linux:

All HTML and CSS files and GRAPHICS directories under */CD-ROM-mount-point/MAN/3021/manual-number* (such as 03004A0D)

For PDF manuals

In Windows:

PDF files under *CD-ROM-drive/MAN/3021/manual-number* (such as 03004A0D)

In Linux:

PDF files under */CD-ROM-mount-point/MAN/3021/manual-number* (such as 03004A0D)

When you copy files, make sure that the PDF files or INDEX . HTM files are placed directly under the directory you created for the PDF manuals or HTML manuals, respectively.

4. Restart PFM - Web Console.

(2) When referencing manuals from the hard disk of the computer being used

To reference manuals from the hard disk of the computer being used, use one of the following methods:

- Use `setup.exe` on the distribution media to install the manuals (applicable to Windows only)
- Directly copy the HTML, CSS, PDF, and GIF files to a desired directory

For HTML manuals, set the directory structure as follows:

html (*contains HTML and CSS files*)

| -GRAPHICS (*contains GIF files*)

3.8.2 How to view manuals

To view a manual:

1. In the Main window of PFM - Web Console, click the **Help** menu in the menu bar to display the Help selection window.
2. Click either a manual name or **PDF** that follows a manual name.
Clicking a manual name displays the HTML version of the manual; clicking **PDF** displays the manual in PDF format.

Notes about using a Web browser

In Windows, if you attempt to display an online manual from the **Start** menu, an HTML manual might be displayed in the window of the Web browser that is already running.

4

Operation in a Cluster System

This chapter describes the installation and setup of PFM - Agent for Enterprise Applications in a cluster system and the operating procedures when PFM - Agent for Enterprise Applications is operated in a cluster system.

4.1 Configuration of PFM - Agent for Enterprise Applications in a cluster system

Use of a cluster system creates a highly reliable system that can continue job execution, even if one of the systems fails, thereby achieving 24-hour Performance Management operation and monitoring.

The following figure shows an example of operations in the event of a failure on the PFM - Agent host in a cluster system.

Figure 4–1: Example of operation in a cluster system (when the PFM - Agent host exists on the same host as the SAP system)

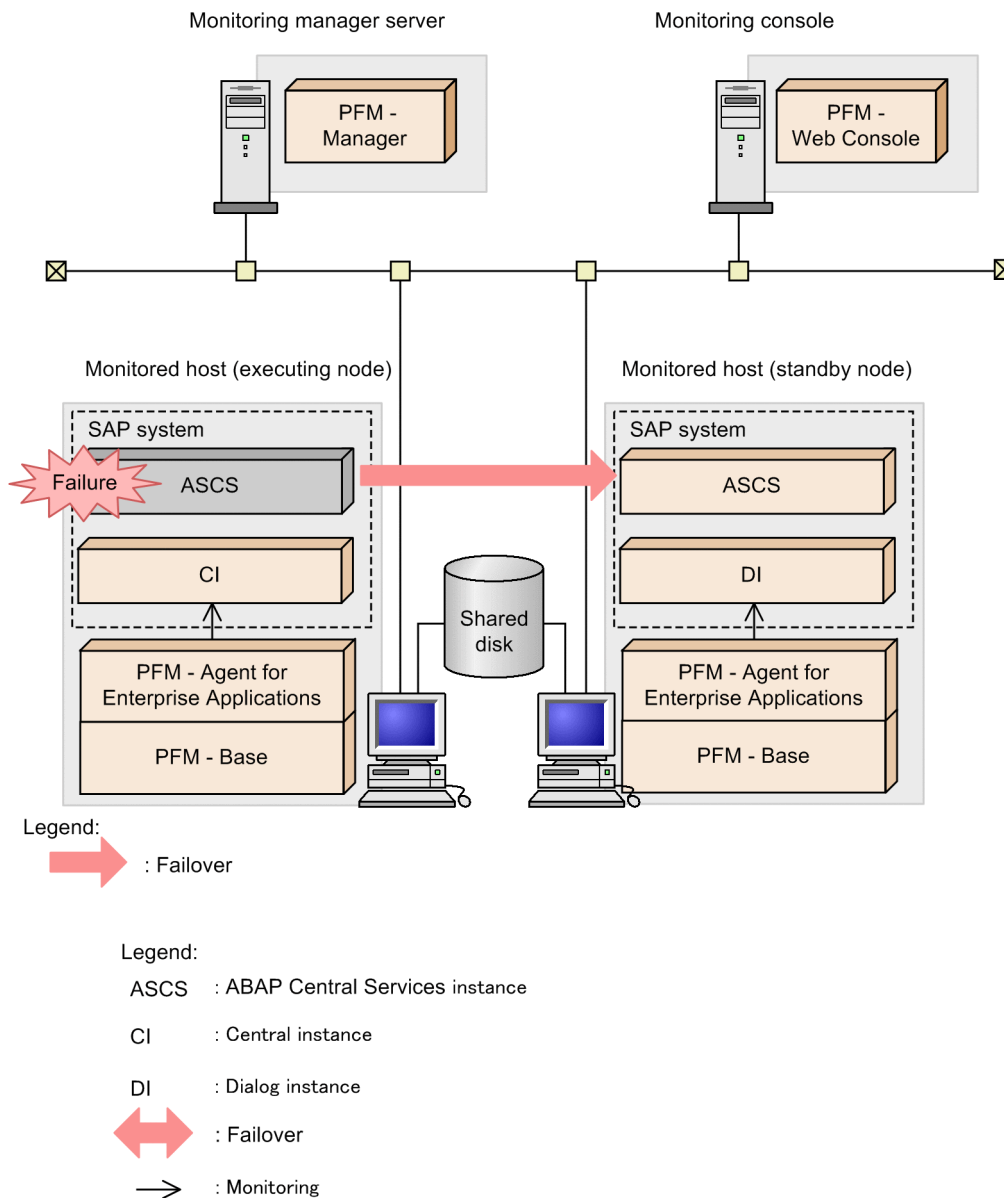

Two environments with the same settings are created. The environment that is normally used for operations is defined as the *executing node*, and the other environment, which is used in the event of a failure, is defined as the *standby node*.

The figure below shows an example of how the SAP system is operated when it is remotely monitored in a cluster system configuration. Because a cluster system is configured to allow an ASCS instance to fail over, the monitored dialog service does not fail over. In this case, perform the same setup that is used for a non-cluster system.

Note

Only a single host within the SAP system can be monitored with a single PFM - Agent for Enterprise Applications.

Figure 4–2: Example of operation in a cluster system (when the SAP system is remotely monitored)

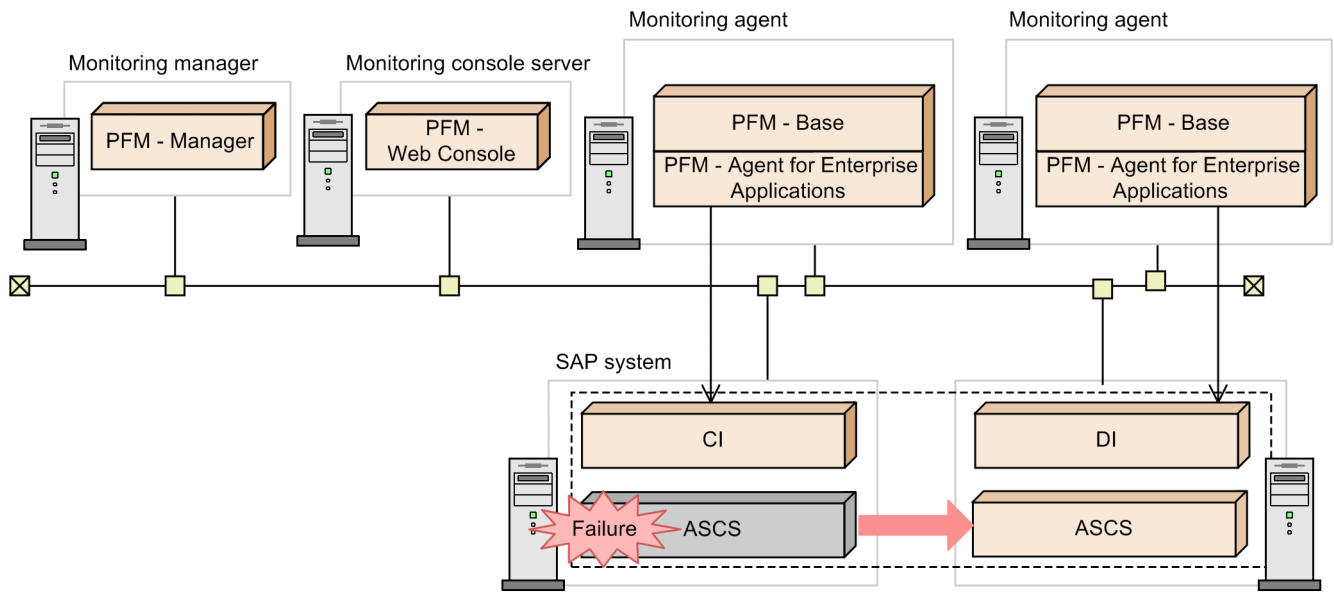

Legend:

ASCS : ABAP Central Services instance

CI : Central instance

DI : Dialog instance

↔ : Failover

→ : Monitoring

4.2 Processing at failover

If a failure occurs on the executing host, control transfers to the standby host.

This section describes the failover processing in the event of a failure on PFM - Agent for Enterprise Applications. It also describes the effects of a PFM - Manager failure on PFM - Agent for Enterprise Applications.

4.2.1 Failover when an error occurs on a PFM - Agent host

This subsection explains the processing when a failover occurs on a PFM - Agent host that is running PFM - Agent for Enterprise Applications.

(1) Processing when failover occurs on a PFM - Agent host (for SAP NetWeaver 7.0 or later)

The following figure shows the processing when failover occurs on a PFM - Agent host for SAP NetWeaver 7.0 or later.

Figure 4–3: Processing when failover occurs on a PFM - Agent host (for SAP NetWeaver 7.0 or later)

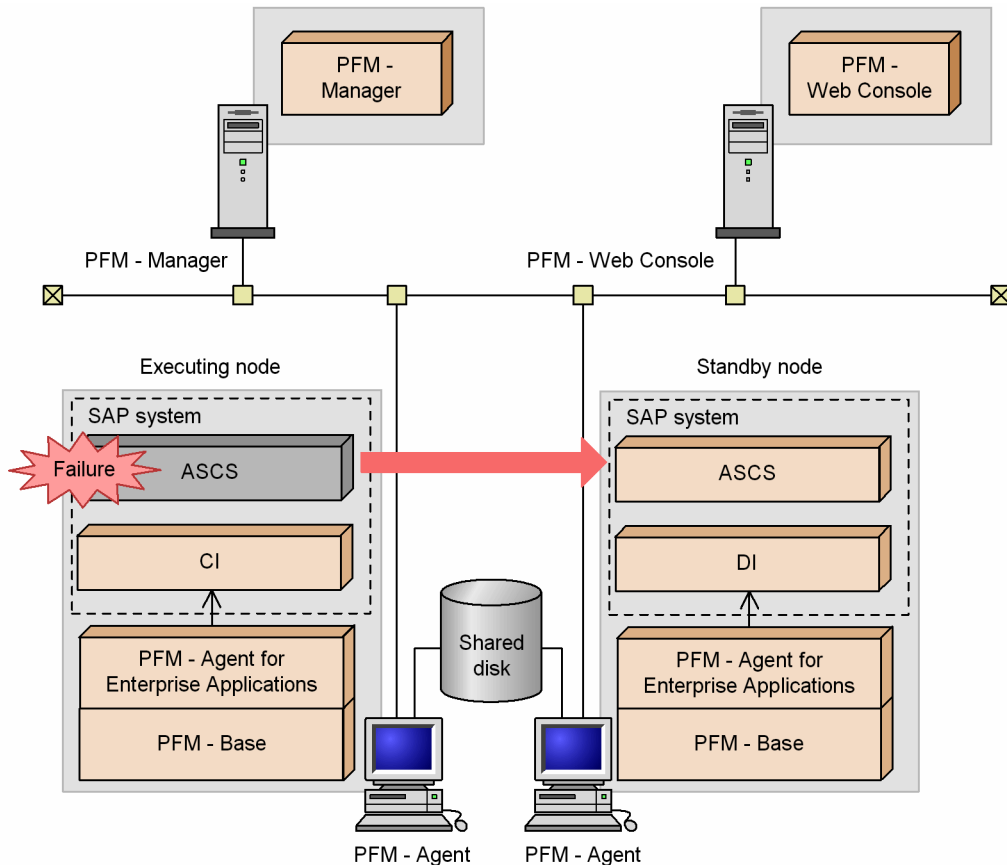

Legend:

ASCS : ABAP Central Services instance

CI : Central instance

DI : Dialog instance

↔ : Failover

→ : Monitoring

A central instance and a dialog instance are running on each node. PFM - Agent for Enterprise Applications monitors these central and dialog instances on each node.

PFM - Agent for Enterprise Applications is set up on each node in the same manner as it would be on a single node and configured to monitor the central and dialog instances on each node. Registration to the cluster software is not performed.

Note

If you monitor PFM - Agent for Enterprise Applications in SAP NetWeaver 7.0 or later, run PFM - Agent for Enterprise Applications on each node in the same manner as it would be on a non-cluster system.

4.2.2 Effects of PFM - Manager failure and the action to be taken

A shutdown of PFM - Manager affects the entire Performance Management system.

PFM - Manager provides centralized management of the agent information for PFM - Agent for Enterprise Applications that is running at all the nodes. It also controls alarm event notifications when thresholds are exceeded during performance monitoring by PFM - Agent for Enterprise Applications, as well as execution of actions based on alarm events. Therefore, when PFM - Manager is shut down, the Performance Management system is affected as described in the following table.

Table 4–1: Effects of PFM - Manager shutdown on PFM - Agent for Enterprise Applications

Program	Effects	Action
PFM - Agent for Enterprise Applications	<p>If PFM - Manager is shut down while PFM - Agent for Enterprise Applications is running, the following occurs:</p> <ul style="list-style-type: none"> • Collection of performance data continues. • Because alarm events cannot be reported to PFM - Manager, the alarm events for each alarm definition are saved and notification for each event is reattempted until PFM - Manager starts. When the number of saved alarm events exceeds 3, the oldest alarm event is overwritten. If PFM - Agent for Enterprise Applications shuts down, the saved alarm events are deleted. • Notifications of alarm status already sent to PFM - Manager are reset when PFM - Manager restarts. Alarm statuses are refreshed once PFM - Manager has checked the status of PFM - Agent for Enterprise Applications. • An attempt to shut down PFM - Agent for Enterprise Applications takes time because notification of this event cannot be sent to PFM - Manager. 	<p>Start PFM - Manager. An active PFM - Agent for Enterprise Applications can continue to operate. Because alarms might not be reported as expected, after PFM - Manager has been recovered, check the KAVE00024-I message that has been output to PFM - Agent's common message log.</p>

You should evaluate your operating procedures, taking into account the effects of a PFM - Manager shutdown. Apart from system crashes, events such as a configuration change or system maintenance might require shutdown of PFM - Manager. You should shut down for maintenance purposes only when the shutdown will have the least effects on operations.

4.3 Installation and setup in a Windows cluster system

This section describes the procedures for constructing and setting up an environment for PFM - Agent for Enterprise Applications in a cluster system.

For details about the procedures for constructing and setting up an environment for PFM - Manager, see the chapter that describes construction and operation in a cluster system in the *JPI/Performance Management Planning and Configuration Guide*.

4.3.1 SAP NetWeaver 7.0 or later (Windows)

(1) Before installation

This subsection describes the prerequisites and required information for starting installation and setup.

(a) Prerequisites

To use PFM - Agent for Enterprise Applications in a cluster system, the following prerequisites must be satisfied.

■ Cluster system

Make sure that the following condition is satisfied:

- The cluster system is controlled by cluster software.

Also, suppress error notification as described below.

Suppressing error notification to Microsoft (executing and standby systems)

In Windows, a dialog box for reporting an error to Microsoft is displayed when an application error occurs. Because this dialog box might cause failover to fail, reporting of the error must be suppressed.

Windows Server 2012

1. From **Control Panel**, select **System and Security**, **Action Center**, and then **Maintenance**.
2. In **Check for solutions to problem reports**, click **Settings**.
3. In the **Windows Error Reporting Configuration** dialog box, select **I don't want to participate, and don't ask me again**.
4. Click the **OK** button.

Windows Server 2016

1. Right-click the Windows **Start** menu, and then select **Run**.
2. Enter `gpedit.msc`, and then click the **OK** button.
The Local Group Policy Editor appears.
3. Click **Computer Configuration**, **Administrative Templates**, **Windows Components**, and then **Windows Error Reporting**.
4. In the right pane, right-click **Disable Windows Error Reporting**, and then select **Edit**.
The settings window appears.
5. In the settings window, select **Enabled**.
6. Click the **OK** button.

(b) Physical host names

Make sure that the following condition is satisfied:

- Each physical host name must be unique in the system.

(2) Flow of tasks from installation to starting operation

The following figure shows the flow of tasks for installing and setting up PFM - Agent for Enterprise Applications.

Figure 4–4: Flow of tasks for installation and setup

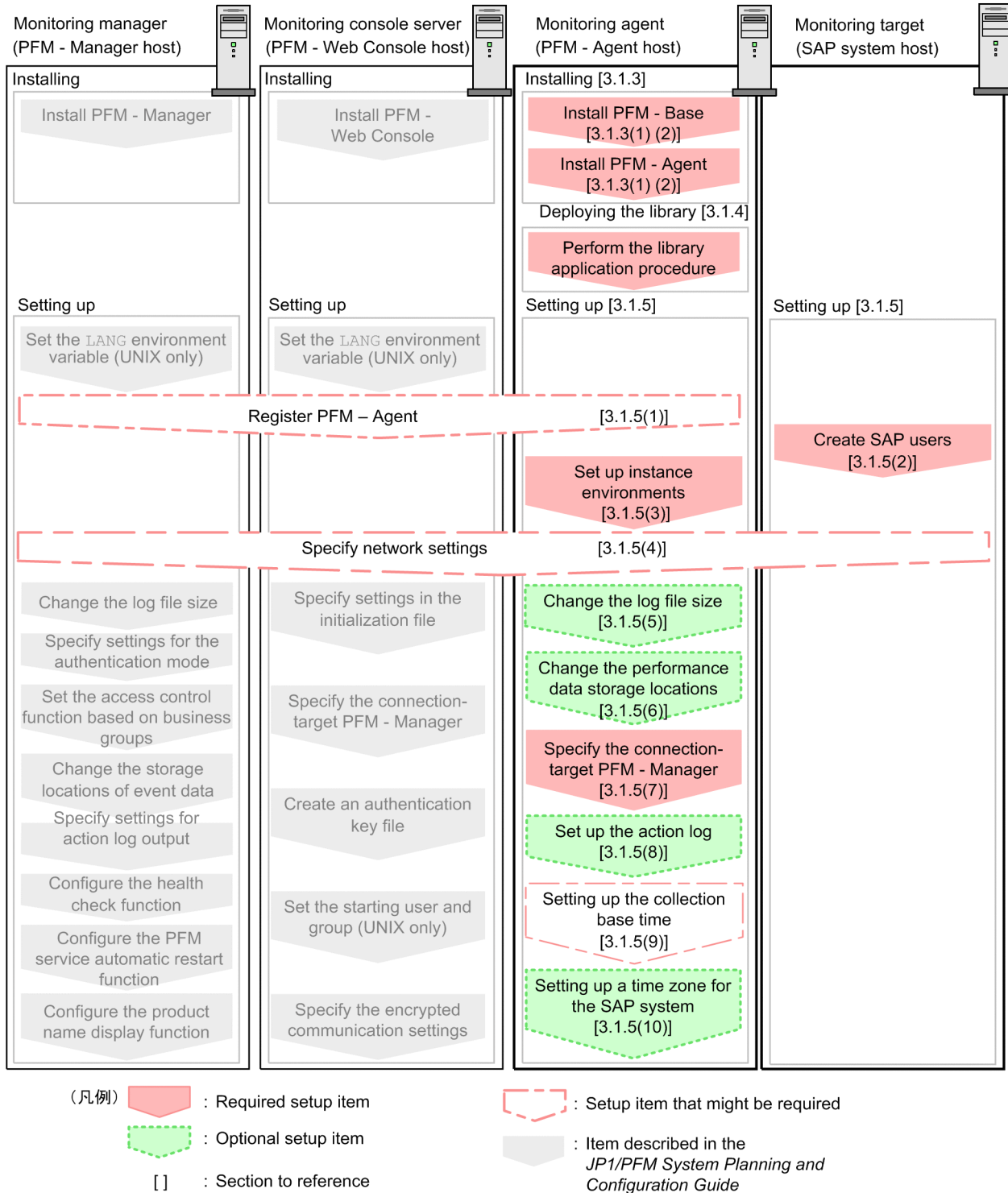

For details about how to install and set up PFM - Manager and PFM - Web Console, see the chapter that describes installation and setup in the *JP1/Performance Management Planning and Configuration Guide*.

(3) Installation

Install PFM - Agent for Enterprise Applications on both executing and standby nodes.

The installation target is the local disk. Do not install PFM - Agent for Enterprise Applications on a shared disk.

The installation procedure is the same as for a non-cluster system. For details about the installation procedure, see [3.1.3 Installation procedure in Windows](#).

(4) Setup

This subsection describes the setup required in order to operate PFM - Agent for Enterprise Applications using SAP NetWeaver 7.0 or later.

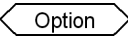
 indicates a setup item that is required depending on the environment or an optional setup item for changing default settings.

(a) Registering PFM - Agent for Enterprise Applications

To achieve central management of PFM - Agent using PFM - Manager and PFM - Web Console, you must register PFM - Agent for Enterprise Applications into PFM - Manager and PFM - Web Console.

If the version of PFM - Manager is 09-00 or later, PFM - Agent is registered automatically, in which case there is no need to perform the procedure described here. However, any data model version of PFM - Agent that is not included in the *Release Notes* for PFM - Manager must be registered manually. For details about the data model version of PFM - Agent for Enterprise Applications, see [Appendix I. Version Compatibility](#).

The following shows the procedure for registering a PFM - Agent.

Figure 4–5: Procedure for registering a PFM - Agent

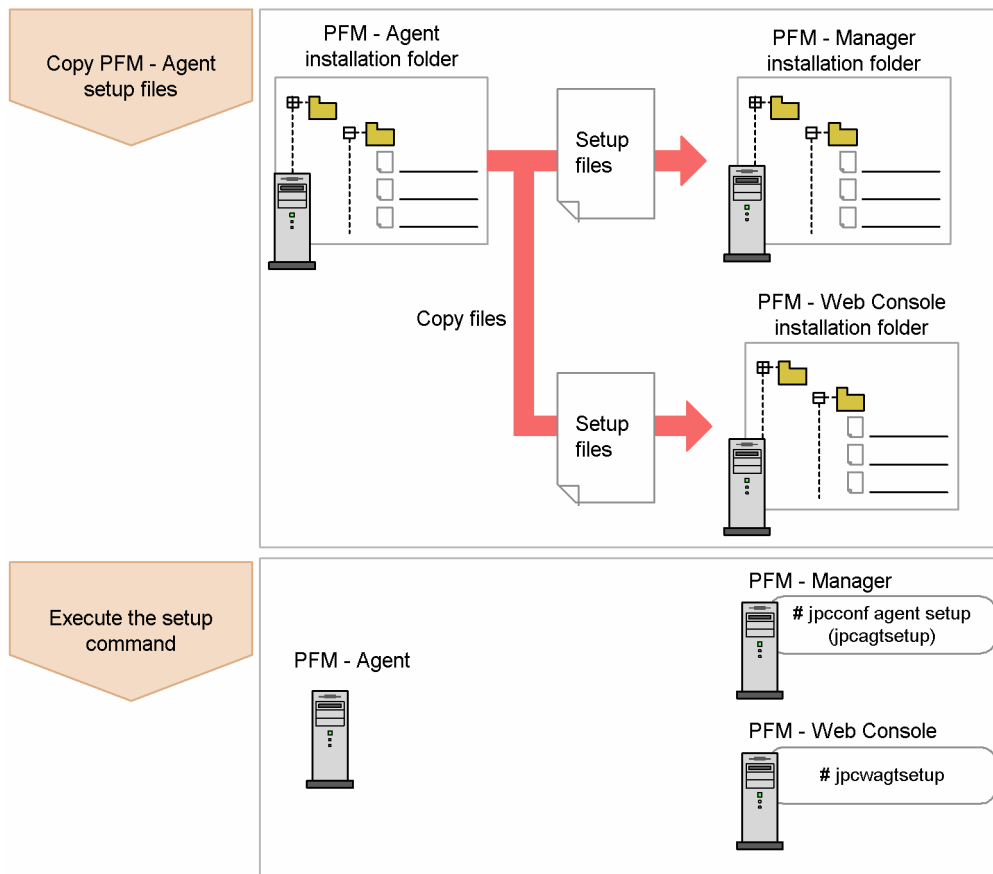

Notes

- Register PFM - Agent before you set up instance environments.
- If you are adding the same version of PFM - Agent for Enterprise Applications to a Performance Management system in which information about PFM - Agent for Enterprise Applications has already been registered, there is no need to register the PFM - Agents.
- If you install a different version of PFM - Agent for Enterprise Applications on a separate host, set up the old version first and then the new version.
- If you have installed PFM - Agent on the same host as PFM - Manager, the `jpcconf agent setup` command executes automatically and the message `KAVE05908-I New agent setup (Pfm-Agent-service-key) ended successfully. (version=version)` is output to the common message log. Check the result; if the command did not execute correctly, re-execute it. For details about executing commands, see the chapter that describes commands in the manual *JPI/Performance Management Reference*.

■ Copying the setup files for PFM - Agent for Enterprise Applications

Copy the setup files from the host where PFM - Agent for Enterprise Applications was installed to the host where PFM - Manager and PFM - Web Console were installed.

To copy the setup files:

1. Stop PFM - Web Console if it is running.
2. Copy the PFM - Agent setup files in the binary mode.

The table below shows the source and target locations of the files to be copied.

Table 4–2: Setup files to be copied

Setup files for PFM - Agent	Target		
	PFM program name	OS	Target folder or directory
<i>installation-folder</i> \setup\jpcagtmw.EXE	PFM - Manager	Windows	<i>PFM-Manager-installation-folder</i> \setup
<i>installation-folder</i> \setup\jpcagtmu.Z		UNIX	/opt/jp1pc/setup/
<i>installation-folder</i> \setup\jpcagtmw.EXE	PFM - Web Console	Windows	<i>PFM-Web-Console-installation-folder</i> \setup
<i>installation-folder</i> \setup\jpcagtmu.Z		UNIX	/opt/jp1pcwebcon/setup/

■ **Executing the setup command at the PFM - Manager host**

To use PFM - Manager to set up PFM - Agent for Enterprise Applications, execute the following command:

```
jpcconf agent setup -key EAP
```

Note

An error might occur if the `jpcconf agent setup` command is executed at a local host where Performance Management programs and services have not stopped completely. If an error occurs, check that all Performance Management programs and services have stopped completely and then re-execute the `jpcconf agent setup` command.

After completing this step, you can delete the PFM - Agent setup files from the PFM - Manager host.

■ **Executing the setup command at the PFM - Web Console host**

To use PFM - Web Console to set up PFM - Agent for Enterprise Applications, execute the following command:

```
jpcwagtsetup
```

After completing this step, you can delete the PFM - Agent setup files from the PFM - Web Console host.

(b) Creating the SAP users that are to be used by PFM - Agent for Enterprise Applications

To collect performance information, PFM - Agent for Enterprise Applications uses RFC (communication protocol of SAP AG) to execute the external management interfaces defined in the SAP system. Therefore, you must prepare in advance the SAP system users who are to be used by PFM - Agent for Enterprise Applications.

This subsection describes the user types, passwords, and authorizations for the SAP users who are created in the SAP system.

■ **User types**

The following types of SAP users can be used by PFM - Agent for Enterprise Applications:

- Dialog
- System

- Communication
- Service

■ Characters permitted for passwords

Define passwords for the SAP users. A password can consist of single-byte numeric characters (from 0 to 9), single-byte alphabetic characters (from a to z, A to Z), and the following single-byte symbols:

!, @, \$, %, &, /, (,), =, ?, ', ` , *, +, ~, #, -, _ , ., :, {, [,], }, <, >, |

■ Required authorizations

You must set the following authorizations (authorization objects) for the users:

- Authorizations required for a user to establish RFC connection with function modules (S_RFC)
- Authorizations required in order to use external management interfaces (S_XMI_PROD)

As the value of each authorization, assign a value shown in the tables below or use the built-in configurations (S_RFC_ALL and S_XMI_ADMIN) that specify an asterisk (*) for all items.

Table 4–3: Authorizations required for a user to establish RFC connection with function modules (S_RFC)

Authorization	Description	Value
RFC_TYPE	Type of RFC object to be protected	FUGR (function group)
RFC_NAME	RFC name to be protected	*
ACTVT	Activity	1 6 (execution)

Table 4–4: Authorizations required in order to use external management interfaces (S_XMI_PROD)

Authorization	Description	Value
EXTCOMPANY	Company name of the external management tool	HITACHI
EXTPRODUCT	Program name of the external management tool	JP1
INTERFACE	Interface ID	*

(c) Setting up instance environments

You must set instance information for each SAP system that is to be monitored by PFM - Agent for Enterprise Applications. You perform the instance information setting at the PFM - Agent host.

The table below lists and describes the instance information items that are to be specified. Check this information before you start the setup procedure. For details about the instance information for an SAP system, see the SAP system documentation.

Table 4–5: Instance information for PFM - Agent for Enterprise Applications

Item	Description	Permitted value	Default value
SID	ID of the SAP system that is to be monitored	Character string (up to 8 bytes)	--
SERVER#1	SAP instance name that is to be monitored (the SAP instance name that has a dialog service, and which can be verified by transaction code SM51)	Character string (up to 20 bytes)	Instance name specified in <code>-inst</code> in the <code>jpccconf inst setup</code> command

Item	Description	Permitted value	Default value
ASHOST#1	Host name of the connection-target application server (the SAP local host, which can be verified by transaction code SM51)	Character string (up to 100 bytes)	Local host name
SYSNR	System number of the SAP system	Numeric characters (up to 2 bytes)	00
CLIENT	Name of client to which the SAP user belongs (system number assigned to the connection-target dialog instance)	Numeric characters (up to 3 bytes)	000
USER	SAP user name	Character string (up to 12 bytes)	--
EXTPWD	Whether to use an extended password to connect to the SAP system	Y or N <ul style="list-style-type: none"> Y: Use an extended password. N: Do not use an extended password. 	Y
PASSWD	Password of the SAP user	<ul style="list-style-type: none"> When an extended password is used: Up to 40 single-byte characters When an extended password is not used: Up to 8 single-byte characters 	--
DELAYCONNECTION	Timing of the connection to the SAP system	Y or N <ul style="list-style-type: none"> Y: Connect to the SAP system only when performance data is collected. The Agent Collector service is started regardless of the operating status of the SAP system at the time of connection establishment. N: Connect to the SAP system when the Agent Collector service starts. The Agent Collector service is not started if the SAP system is not active at the time of connection establishment. 	N
Store Version#2	Store version to be used. For details about the Store version, see 3.6.2 Updating the Store version to 2.0.	{1.0 2.0}	2.0

Legend:

--: None

#1

To use the remote monitoring function, you have to set both the SAP instance name to be monitored and the host name of the SAP system.

#2

This setting is required when the version of PFM - Agent for Enterprise Applications is 09-00 or later, and the version of PFM - Base or PFM - Manager on the same host is 08-11 or later, and you are setting up an instance environment for the first time.

Notes

- If no instance environment has been set up, the PFM - Agent for Enterprise Applications service cannot be started.
- Only a single host within the SAP system can be monitored with a single PFM - Agent for Enterprise Applications.

When you are monitoring a SAP system configured with multiple hosts (as in the case where a distributed configuration or cluster system is used for operation), you have to prepare as many pieces of PFM - Agent for Enterprise Applications as the number of hosts to be monitored, as shown in the figure below.

Figure 4–6: Example of a SAP system configured with multiple hosts

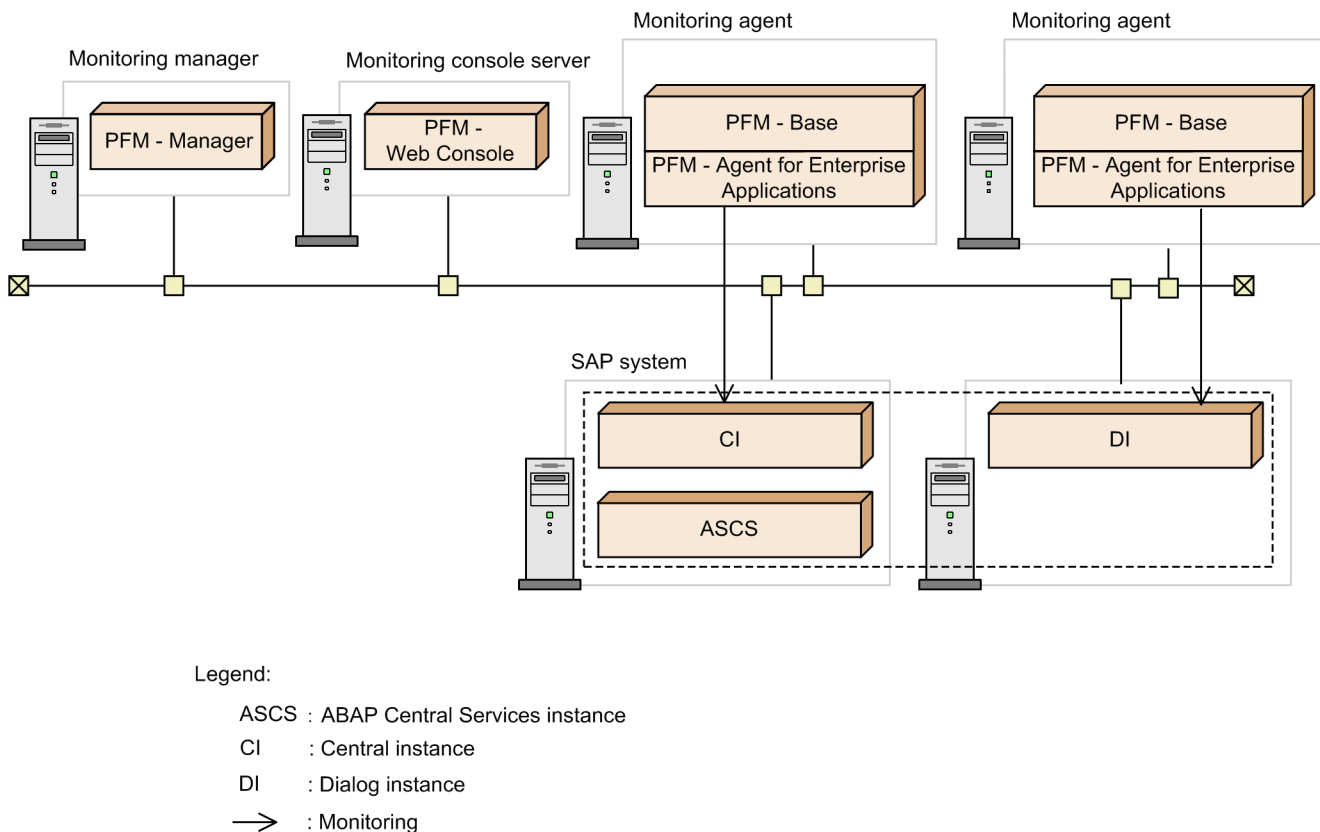

You use the `jpccnf inst setup` command to construct an instance environment.

To construct an instance environment:

1. Execute the `jpccnf inst setup` command with the service key and instance name specified.

For example, to construct an instance environment for the instance named `o246bciSD500` for PFM - Agent for Enterprise Applications, execute the following command:

```
jpccnf inst setup -key EAP -inst o246bciSD500
```

Although you can use any instance name in PFM - Agent for Enterprise Applications, to simplify management we recommend that you use an instance name that identifies the SAP system that is to be monitored. Normally, a name in the format `host-name_SAP-system-ID_system-number` is assigned to an instance for an SAP system.

Note that no underscore (`_`) is allowed in the `jpccnf inst setup` command. For example, if the instance name of SAP system is `o246bci_SD5_00`, specify `o246bciSD500` as the instance name of PFM - Agent for Enterprise Applications.

2. Specify instance information for the SAP system.

Enter the information shown in [Table 4-5 Instance information for PFM - Agent for Enterprise Applications](#), in accordance with the command's instructions. You cannot omit any requested items. To use a displayed value (which is the default) press the **Enter** key.

Once you have entered all items, the instance environment is constructed. The following describes constructed instance environments:

- Organization of folders for instance environments

Instance environments are constructed in the following folder:

- When running a physical host: *installation-folder*\agtm

The following table shows the organization of the folders for instance environments.

Table 4–6: Organization of folders for instance environments

Folder and file names			Description
agent	<i>instance-name</i>	jpcagt.ini	Agent Collector service startup initialization file
		jpcagt.ini.model#	Model file for the Agent Collector service startup initialization file
		jpcMcollect.ini	Environment parameters file for SAP communications process
		jr3alget.ini	Environment parameters file for CCMS Alert Monitor Command (PD_ALMX) records
		jr3slget.ini	Environment parameters file for System Log Monitor Command (PD_SLMX) records
		log	Storage folder for log files
store	<i>instance-name</i>	jpcsto.ini	Agent Store service startup initialization file
		jpcsto.ini.model#	Model file for the Agent Store service startup initialization file
		*.DAT	Data model definition file
		dump	Export folder
		backup	Backup folder
		import	Import folder (for Store version 2.0)
		log	Storage folder for log files
		partial	Partial backup folder (for Store version 2.0)
		STPD	Performance data storage folder for the PD record type (for Store version 2.0)
		STPI	Performance data storage folder for the PI record type (for Store version 2.0)
		STPL	Performance data storage folder for the PL record type (for Store version 2.0)

#

You can use this file to restore the settings that were in effect before the instance environment was constructed.

- Service ID for an instance environment

The service ID for an instance environment is a character string that consists of a product ID, function ID, instance number, instance name, and host name. For example, service ID `MA1o246bcisD500[host01]` represents the following instance environment:

- Product ID: M
- Function ID: A
- Instance number: 1
- Instance name: o246bcisD500

- Host name: `host01`

For details about the service ID, see the appendix in the *JPI/Performance Management Planning and Configuration Guide*.

- Windows service name for instance environments

The following are the Windows service names for instance environments:

- Agent Collector service: `PFM - Agent for R/3 instance-name`
- Agent Store service: `PFM - Agent Store for R/3 instance-name`

For details about the Windows service names, see the appendix in the *JPI/Performance Management Planning and Configuration Guide*.

(5) Specifying network settings Option

You must specify network settings only when you change the network configuration where Performance Management is used.

You can set the following two network settings items:

- IP addresses

Set this information to use Performance Management in a network that is connected to multiple LANs. To set multiple IP addresses, define the host names and IP addresses in the `jpchosts` file. Make sure that the settings in the `jpchosts` file are consistent throughout the entire Performance Management system.

For details, see the chapter that describes installation and setup in the *JPI/Performance Management Planning and Configuration Guide*.

- Port numbers

You can set the port numbers used by Performance Management. To avoid confusion during operation, make sure that the specified port numbers and service names are consistent throughout the entire Performance Management system.

For details about setting port numbers, see the chapter that describes installation and setup in the *JPI/Performance Management Planning and Configuration Guide*.

(a) Changing the log file size Option

Performance Management's operating status is output to a log file unique to Performance Management. This setting is required only when you wish to change this file size.

For details, see the chapter that describes installation and setup in the *JPI/Performance Management Planning and Configuration Guide*.

(b) Changing the performance data storage locations Option

These settings are required only when you wish to change the storage location, backup folder, export folder, partial backup folder, or import folder for the database that stores the performance data managed by PFM - Agent for Enterprise Applications.

The default storage locations for the performance data are as follows:

Storage location	Folder name
Database storage location	<ul style="list-style-type: none"> • In the case of a physical host <code>installation-folder\agtm\store\instance-name\</code> • In the case of a logical host

Storage location	Folder name
Database storage location	<i>environment-directory</i> #\jplpc\agtm\store\ <i>instance-name</i> \
Backup location	<ul style="list-style-type: none"> In the case of a physical host <i>installation-folder</i>\agtm\store\<i>instance-name</i>\backup\ In the case of a logical host <i>environment-directory</i>#\jplpc\agtm\store\<i>instance-name</i>\backup\
Export location	<ul style="list-style-type: none"> In the case of a physical host <i>installation-folder</i>\agtm\store\<i>instance-name</i>\dump\ In the case of a logical host <i>environment-directory</i>#\jplpc\agtm\store\<i>instance-name</i>\dump\
Partial backup location (for Store version 2.0)	<ul style="list-style-type: none"> In the case of a physical host <i>installation-folder</i>\agtm\store\<i>instance-name</i>\partial\ In the case of a logical host <i>environment-directory</i>#\jplpc\agtm\store\<i>instance-name</i>\partial\
Import location (for Store version 2.0)	<ul style="list-style-type: none"> In the case of a physical host <i>installation-folder</i>\agtm\store\<i>instance-name</i>\import\ In the case of a logical host <i>environment-directory</i>#\jplpc\agtm\store\<i>instance-name</i>\import\

The environment directory resides on a shared disk specified upon the creation of the logical host.

For details, see [3.6.1 Changing the performance data storage location](#).

(c) Specifying the connection-target PFM - Manager for PFM - Agent for Enterprise Applications

On the host where a PFM - Agent is installed, you must specify the PFM - Manager that manages that PFM - Agent. You use the `jpcconf mgrhost define` command to set the connection-target PFM - Manager.

Notes

- There can be only one PFM - Manager as the connection destination even when multiple PFM - Agents are installed on the same host. Different PFM - Managers cannot be specified for the various PFM - Agents.
- If a PFM - Agent and PFM - Manager are installed on the same host, that PFM - Manager on the local host is automatically the connection-target PFM - Manager; you cannot change the connection-target PFM - Manager to some other PFM - Manager.

To specify the connection-target PFM - Manager:

1. Stop all Performance Management programs and services.

Before you start the setup procedure, you must terminate all Performance Management programs and services that are running on the local host. For details about stopping services, see the chapter that describes starting and stopping services in the *JPI/Performance Management User's Guide*.

If a Performance Management program or service remains active during execution of the `jpcconf mgrhost define` command, a message is displayed that asks you to terminate the program.

2. Execute the `jpcconf mgrhost define` command with the host name of the connection-target PFM - Manager specified.

For example, if the connection-target PFM - Manager is on host `host01`, specify the command as follows:

```
jpccconf mgrhost define -host host01
```

(d) Specifying the settings for outputting action log data Option

You can log information into the action log when, for example, PFM services start and stop, or when the status of the connection to PFM - Manager changes. The action log stores historical information that is output in conjunction with the alarms for thresholds related to system load and other conditions.

For details about how to set up the action log, see *Appendix J. Outputting Action Log Data*.

(e) Setting up the collection base time

To use the remote monitoring function, you have to set the collection base time for the system log information extraction function and the CCMS alert information extraction function. For details about how to set the environment parameters file and the relevant settings, see *5.3 Environment parameters file* and *6.3 Environment parameters file*.

(f) Setting up a time zone for the SAP system Option

To use the remote monitoring function, you have to set a time zone (time difference from UTC) for the SAP system, which will be taken into consideration by the system log information extraction function. For details about how to set the environment parameters file and the relevant settings, see *5.3 Environment parameters file* and *6.3 Environment parameters file*.

4.4 Installation and setup in a Linux cluster system

4.4.1 SAP NetWeaver 7.0 or later (Linux)

(1) Before installation

This subsection describes the prerequisites and required information for starting installation and setup.

(a) Prerequisites

To use PFM - Agent for Enterprise Applications in a cluster system, the following prerequisites must be satisfied.

(b) Cluster system

Make sure that the following condition is satisfied:

- The cluster system is controlled by cluster software.

(c) Physical host names

Make sure that the following condition is satisfied:

- Each physical host name must be unique in the system.

(2) Flow of tasks from installation to starting operation

The following figure shows the flow of tasks for installing and setting up PFM - Agent for Enterprise Applications.

Figure 4–7: Flow of tasks for installation and setup

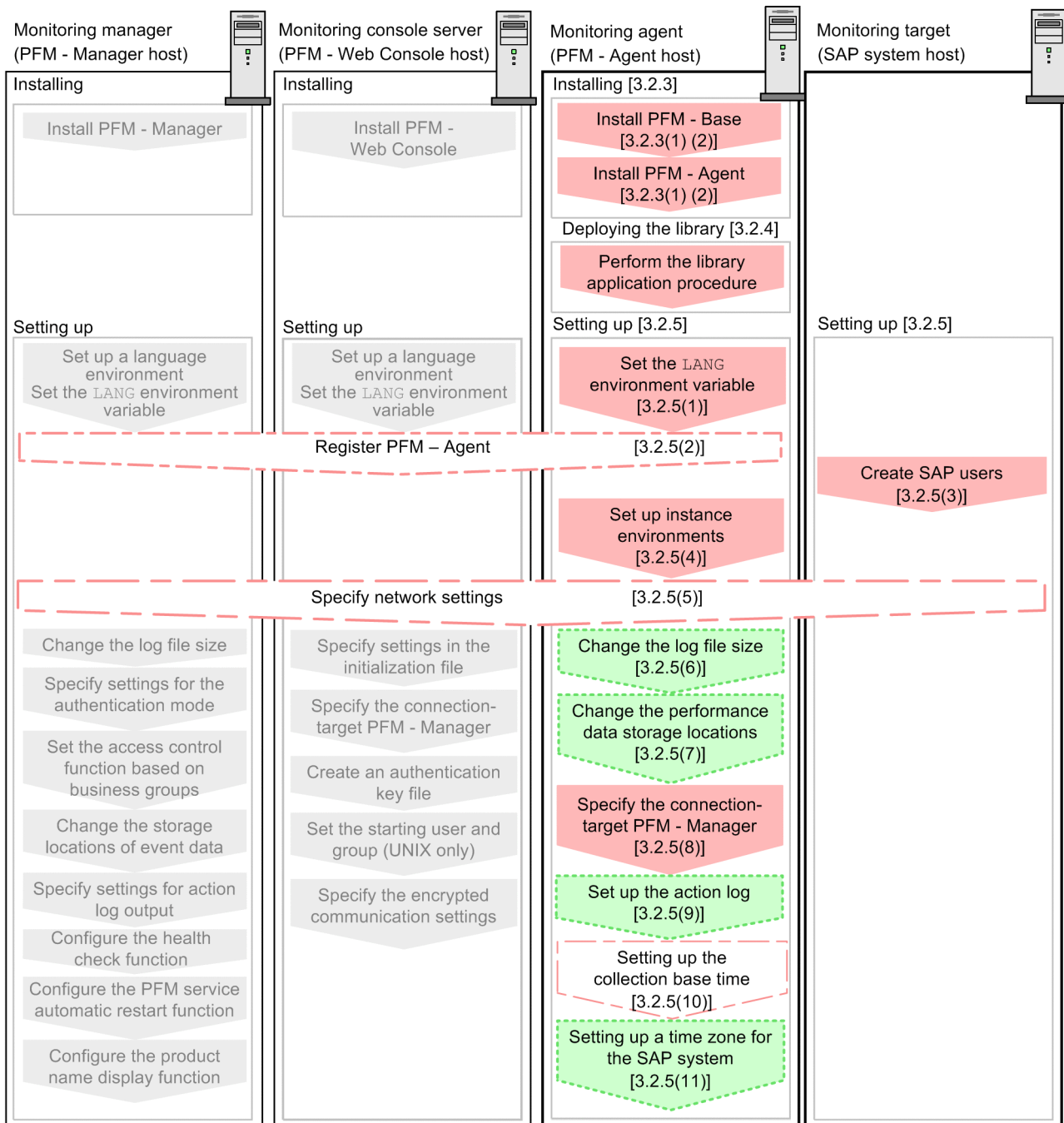

Legend:

- ▭ : Required setup item
- ▭ : Optional setup item
- ▭ : Setup item that might be required
- ▭ : Item described in the JP1/PFM System Planning and Configuration Guide
- [] : Section to reference

For details about how to install and set up PFM - Manager and PFM - Web Console, see the chapter that describes installation and setup in the *JP1/Performance Management Planning and Configuration Guide*.

(3) Installation

Install PFM - Agent for Enterprise Applications on both executing and standby nodes.

The installation target is the local disk. Do not install PFM - Agent for Enterprise Applications on a shared disk.

The installation procedure is the same as for a non-cluster system. For details about the installation procedure, see [3.2.3 Installation procedure in Linux](#).

(4) Setup

This subsection describes the setup required in order to operate PFM - Agent for Enterprise Applications.

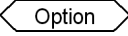
 indicates a setup item that is required depending on the environment or an optional setup item for changing default settings.

(a) Specifying the LANG environment variable

The table below shows the LANG environment variable value supported by PFM - Agent for Enterprise Applications.

Before you specify the LANG environment variable, make sure that the correct language environment has been installed and constructed. If the language environment is incorrect, encoding errors might occur or definition data might be replaced with invalid data.

Note

The LANG environment variable specified at the time of service startup or command execution determines the language used for the common message log.

Table 4–7: LANG environment variable value supported by PFM - Agent for Enterprise Applications

OS	Language		LANG environment variable value
Linux	Japanese	Shift-JIS encoding	ja_JP.SJIS# ja_JP.sjis#
		UTF-8 encoding	ja_JP.UTF-8
	English (no Japanese)		C
	Chinese (simplified)	GB18030	zh_CN.gb18030
		UTF-8	zh_CN.UTF-8 zh_CN.utf8

#: Available only for SUSE Linux

(b) Registering PFM - Agent for Enterprise Applications

To achieve central management of PFM - Agent using PFM - Manager and PFM - Web Console, you must register PFM - Agent for Enterprise Applications into PFM - Manager and PFM - Web Console.

If the version of PFM - Manager is 09-00 or later, PFM - Agent is registered automatically, in which case there is no need to perform the procedure described here. However, any data model version of PFM - Agent that is not included in the *Release Notes* for PFM - Manager must be registered manually. For details about the data model version of PFM - Agent for Enterprise Applications, see [Appendix I. Version Compatibility](#).

The following shows the procedure for registering a PFM - Agent.

Figure 4–8: Procedure for registering a PFM - Agent

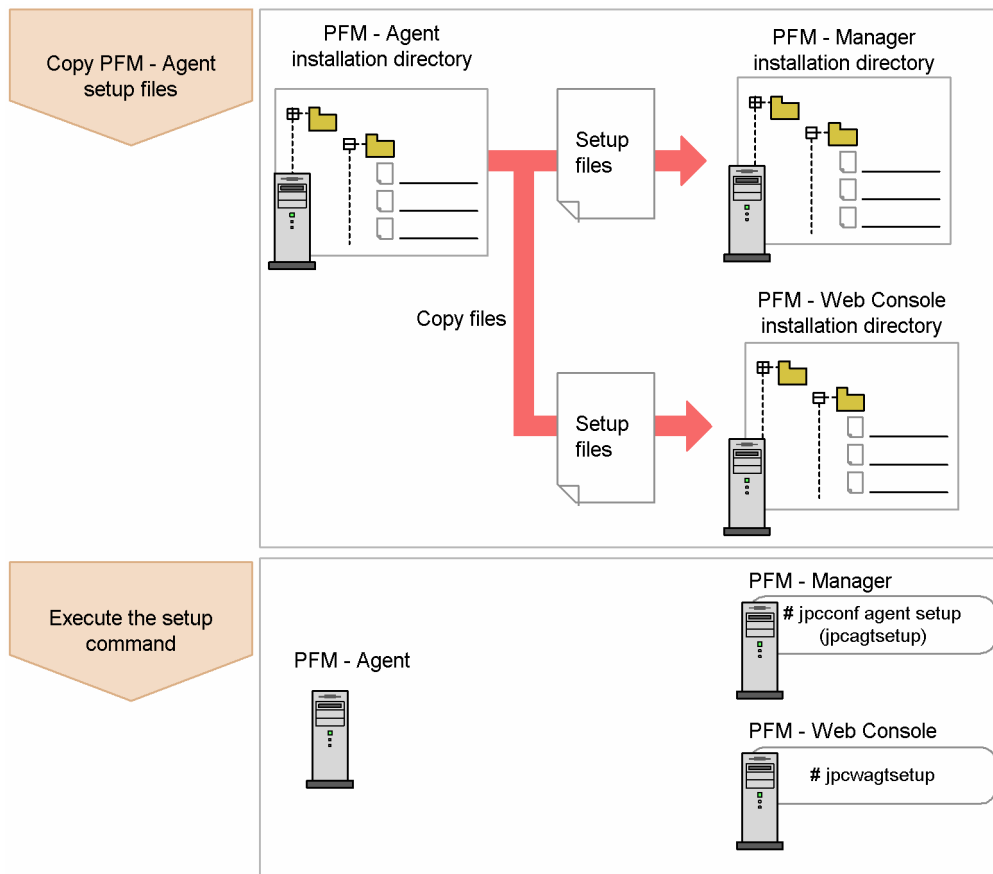

Notes

- Register PFM - Agent before you set up instance environments.
- If you are adding the same version of PFM - Agent for Enterprise Applications to a Performance Management system in which information about PFM - Agent for Enterprise Applications has already been registered, there is no need to register the PFM - Agents.
- If you install a different version of PFM - Agent for Enterprise Applications on a separate host, set up the old version first and then the new version.
- If you have installed PFM - Agent on the same host as PFM - Manager, the `jpcconf agent setup` command executes automatically and the message `KAVE05908-I New agent setup (Pfm-Agent-service-key) ended successfully. (version=version)` is output to the common message log. Check the result; if the command did not execute correctly, re-execute it. For details about executing commands, see the chapter that describes commands in the manual *JPI/Performance Management Reference*.

■ Copying the setup files for PFM - Agent for Enterprise Applications

Copy the setup files from the host where PFM - Agent for Enterprise Applications was installed to the host where PFM - Manager and PFM - Web Console were installed.

To copy the setup files:

1. Stop PFM - Web Console if it is running.
2. Copy the PFM - Agent setup files in the binary mode.

The table below shows the source and target locations of the files to be copied.

Table 4–8: Setup files to be copied

Setup files for PFM - Agent	Target		
	PFM program name	OS	Target folder or directory
/opt/jp1pc/setup/jpcagtmw.EXE	PFM - Manager	Windows	<i>PFM-Manager-installation-folder</i> \setup
/opt/jp1pc/setup/jpcagtmu.Z		UNIX	/opt/jp1pc/setup/
/opt/jp1pc/setup/jpcagtmw.EXE	PFM - Web Console	Windows	<i>PFM-Web-Console-installation-folder</i> \setup
/opt/jp1pc/setup/jpcagtmu.Z		UNIX	/opt/jp1pcwebcon/setup/

■ **Executing the setup command at the PFM - Manager host**

To use PFM - Manager to set up PFM - Agent for Enterprise Applications, execute the following command:

```
jpcconf agent setup -key EAP
```

Note

An error might occur if the `jpcconf agent setup` command is executed at a local host where Performance Management programs and services have not stopped completely. If an error occurs, check that all Performance Management programs and services have stopped completely and then re-execute the `jpcconf agent setup` command.

After completing this step, you can delete the PFM - Agent setup files from the PFM - Manager host.

■ **Executing the setup command at the PFM - Web Console host**

To use PFM - Web Console to set up PFM - Agent for Enterprise Applications, execute the following command:

```
jpcwagtsetup
```

After completing this step, you can delete the PFM - Agent setup files from the PFM - Web Console host.

(c) Creating the SAP users that are to be used by PFM - Agent for Enterprise Applications

To collect performance information, PFM - Agent for Enterprise Applications uses RFC (communication protocol of SAP AG) to execute the external management interfaces defined in the SAP system. Therefore, you must prepare in advance the SAP system users who are to be used by PFM - Agent for Enterprise Applications.

This subsection describes the user types, passwords, and authorizations for the SAP users who are created in the SAP system.

■ **User types**

The following types of SAP users can be used by PFM - Agent for Enterprise Applications:

- Dialog
- System

- Communication
- Service

■ Characters permitted for passwords

Define passwords for the SAP users. A password can consist of single-byte numeric characters (from 0 to 9), single-byte alphabetic characters (from a to z, A to Z), and the following single-byte symbols:

!, @, \$, %, &, /, (,), =, ?, ', ` , *, +, ~, #, -, _ , ., :, {, [,], }, <, >, |

■ Required authorizations

You must set the following authorizations (authorization objects) for the users:

- Authorizations required for a user to establish RFC connection with function modules (S_RFC)
- Authorizations required in order to use external management interfaces (S_XMI_PROD)

For the value of each authorization, assign a value shown in the tables below or use the built-in configurations (S_RFC_ALL and S_XMI_ADMIN) that specify an asterisk (*) for all items.

Table 4–9: Authorizations required for a user to establish RFC connection with function modules (S_RFC)

Authorization	Description	Value
RFC_TYPE	Type of RFC object to be protected	FUGR (function group)
RFC_NAME	RFC name to be protected	*
ACTVT	Activity	1 6 (execution)

Table 4–10: Authorizations required in order to use external management interfaces (S_XMI_PROD)

Authorization	Description	Value
EXTCOMPANY	Company name of the external management tool	HITACHI
EXTPRODUCT	Program name of the external management tool	JP1
INTERFACE	Interface ID	*

(d) Setting up instance environments

You must set instance information for each SAP system that is to be monitored by PFM - Agent for Enterprise Applications. You perform the instance information setting at the PFM - Agent host.

The table below lists and describes the instance information items that are to be specified. Check this information before you start the setup procedure. For details about the instance information for an SAP system, see the SAP system documentation.

Table 4–11: Instance information for PFM - Agent for Enterprise Applications

Item	Description	Permitted value	Default value
SID	ID of the SAP system that is to be monitored	Character string (up to 8 bytes)	--

Item	Description	Permitted value	Default value
SERVER ^{#1}	SAP instance name that is to be monitored (the SAP instance name that has a dialog service, and which can be verified by transaction code SM51)	Character string (up to 20 bytes)	Instance name specified in <code>-inst</code> in the <code>jpccconf inst setup</code> command
ASHOST ^{#1}	Host name of the connection-target application server (the SAP local host, which can be verified by transaction code SM51)	Character string (up to 100 bytes)	Local host name
SYSNR	System number of the SAP system	Numeric characters (up to 2 bytes)	00
CLIENT	Name of client to which the SAP user belongs (system number assigned to the connection-target dialog instance)	Numeric characters (up to 3 bytes)	000
USER	SAP user name	Character string (up to 12 bytes)	--
EXTPWD	Whether to use an extended password to connect to the SAP system	Y or N <ul style="list-style-type: none"> Y: Use an extended password. N: Do not use an extended password. 	Y
PASSWD	Password of the SAP user	<ul style="list-style-type: none"> When an extended password is used: 1 to 40 single-byte characters When an extended password is not used: 1 to 8 single-byte characters 	--
DELAYCONNECT	Timing of the connection to the SAP system	Y or N <ul style="list-style-type: none"> Y: Connect to the SAP system only when performance data is collected. The Agent Collector service is started regardless of the operating status of the SAP system at the time of connection establishment. N: Connect to the SAP system when the Agent Collector service starts. The Agent Collector service is not started if the SAP system is not active at the time of connection establishment. 	N
Store Version ^{#2}	Store version to be used. For details about the Store version, see 3.6.2 Updating the Store version to 2.0.	{1.0 2.0}	2.0

Legend:

--: None

#1

To use the remote monitoring function, you have to set both the SAP instance name to be monitored and the host name of the SAP system.

#2

- This setting is required when the version of PFM - Agent for Enterprise Applications is 09-00 or later, and the version of PFM - Base or PFM - Manager on the same host is 08-11 or later, and you are setting up an instance environment for the first time.
- Only a single host within the SAP system can be monitored with a single PFM - Agent for Enterprise Applications.

When you are monitoring a SAP system configured with multiple hosts (as in the case where a distributed configuration or cluster system is used for operation), you have to prepare as many pieces of PFM - Agent for Enterprise Applications as the number of hosts to be monitored, as shown in the figure below.

Figure 4–9: Example of a SAP system configured with multiple hosts

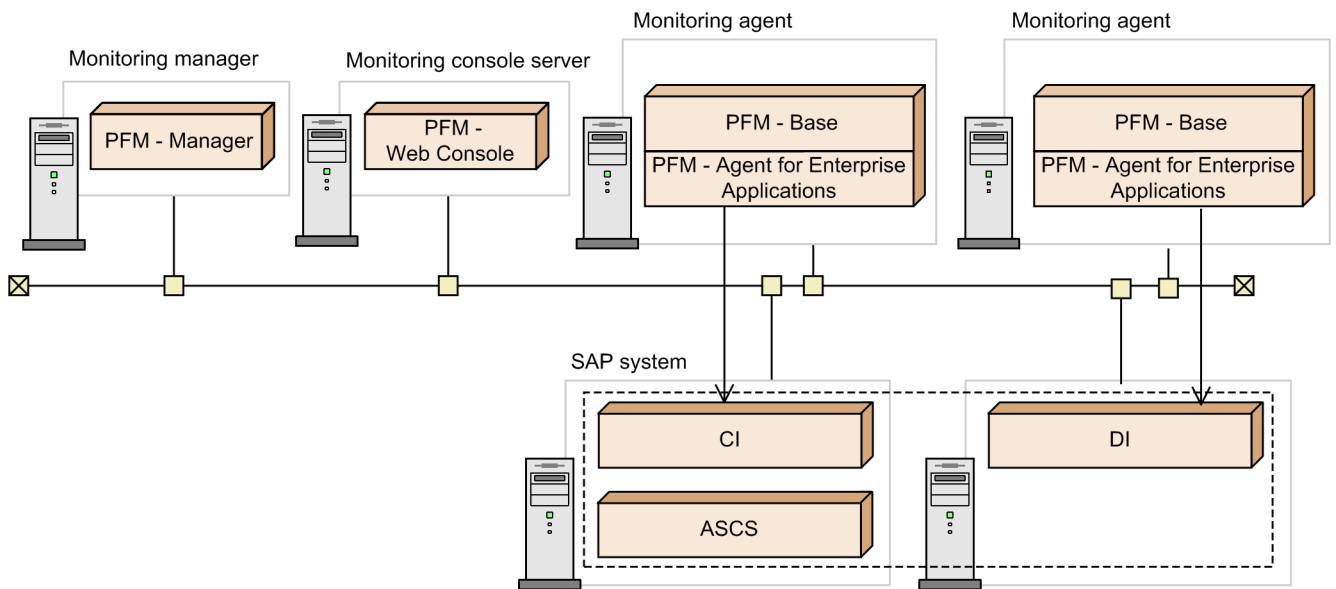

Legend:

- ASCS : ABAP Central Services instance
- CI : Central instance
- DI : Dialog instance
- : Monitoring

Note

- If no instance environment has been set up, the PFM - Agent for Enterprise Applications service cannot be started.

You use the `jpccconf inst setup` command to construct an instance environment.

To construct an instance environment:

1. Execute the `jpccconf inst setup` command with the service key and instance name specified.

For example, to construct an instance environment for the instance named `o246bciSD500` for PFM - Agent for Enterprise Applications, execute the following command:

```
jpccconf inst setup -key EAP -inst o246bciSD500
```

Although you can use any instance name in PFM - Agent for Enterprise Applications, to simplify management we recommend that you use an instance name that identifies the SAP system that is to be monitored. Normally, a name in the format `host-name_SAP-system-ID_system-number` is assigned to an instance for an SAP system.

Note that no underscore (`_`) is allowed in the `jpccconf inst setup` command. For example, if the instance name of SAP system is `o246bci_SD5_00`, specify `o246bciSD500` as the instance name of PFM - Agent for Enterprise Applications.

2. Specify instance information for the SAP system.

Enter the information shown in [Table 4-11 Instance information for PFM - Agent for Enterprise Applications](#), in accordance with the command's instructions. You cannot omit any requested items. To use a displayed value (which is the default) press the **Enter** key.

Once you have entered all items, the instance environment is constructed. The following describes constructed instance environments:

- Organization of directories for instance environments

Instance environments are constructed in the following directory:

- When running a physical host: /opt/jp1pc/agtm

The following table shows the organization of the directories for instance environments.

Table 4–12: Organization of directories for instance environments

Directory and file names			Description
agent	<i>instance-name</i>	jpcagt.ini	Agent Collector service startup initialization file
		jpcagt.ini.model#	Model file for the Agent Collector service startup initialization file
		jpcMcollect.ini	Environment parameters file for SAP communications process
		j3alget.ini	Environment parameters file for CCMS Alert Monitor Command (PD_ALMX) records
		j3slget.ini	Environment parameters file for System Log Monitor Command (PD_SLMX) records
		log	Storage directory for log files
store	<i>instance-name</i>	jpcsto.ini	Agent Store service startup initialization file
		jpcsto.ini.model#	Model file for the Agent Store service startup initialization file
		*.DAT	Data model definition file
		dump	Export directory
		backup	Backup directory
		import	Import directory (for Store version 2.0)
		log	Storage directory for log files
		partial	Partial backup directory (for Store version 2.0)
		STPD	Performance data storage directory for the PD record type (for Store version 2.0)
		STPI	Performance data storage directory for the PI record type (for Store version 2.0)
		STPL	Performance data storage directory for the PL record type (for Store version 2.0)

#

You can use this file to restore the settings that were in effect before the instance environment was constructed.

- Service ID for an instance environment

The service ID for an instance environment is a character string that consists of a product ID, function ID, instance number, instance name, and host name. For example, service ID MA1o246bc1SD500[host01] represents the following instance environment:

- Product ID: M
- Function ID: A

- Instance number: 1
- Instance name: o246bcisd500
- Host name: host01

For details about the service ID, see the appendix in the *JPI/Performance Management Planning and Configuration Guide*.

(5) Specifying network settings Option

You must specify network settings only when you change the network configuration where Performance Management is used.

You can set the following two network settings items:

- IP addresses

Set this information to use Performance Management in a network that is connected to multiple LANs. To set multiple IP addresses, define the host names and IP addresses in the `jpchosts` file. Make sure that the settings in the `jpchosts` file are consistent throughout the entire Performance Management system.

For details, see the chapter that describes installation and setup in the *JPI/Performance Management Planning and Configuration Guide*.

- Port numbers

You can set the port numbers used by Performance Management. To avoid confusion during operation, make sure that the specified port numbers and service names are consistent throughout the entire Performance Management system.

For details about setting port numbers, see the chapter that describes installation and setup in the *JPI/Performance Management Planning and Configuration Guide*.

(a) Changing the log file size Option

Performance Management's operating status is output to a log file unique to Performance Management. This setting is required only when you wish to change this file size.

For details, see the chapter that describes installation and setup in the *JPI/Performance Management Planning and Configuration Guide*.

(b) Changing the performance data storage locations Option

These settings are required only when you wish to change the storage location, backup directory, export directory, partial backup directory, or import directory for the database that stores the performance data managed by PFM - Agent for Enterprise Applications.

The default storage locations for the performance data are as follows:

Storage location	Directory name
Database storage location	<ul style="list-style-type: none"> • In the case of a physical host <code>/opt/jplpc/agtmd/store/instance-name/</code> • In the case of a logical host <code>environment-directory#/jplpc/agtmd/store/instance-name/</code>
Backup location	<ul style="list-style-type: none"> • In the case of a physical host <code>/opt/jplpc/agtmd/store/instance-name/backup/</code> • In the case of a logical host

Storage location	Directory name
Backup location	<code>environment-directory[#]/jplpc/agtm/store/instance-name/backup/</code>
Export location	<ul style="list-style-type: none"> In the case of a physical host <code>/opt/jplpc/agtm/store/instance-name/dump/</code> In the case of a logical host <code>environment-directory[#]/jplpc/agtm/store/instance-name/dump/</code>
Partial backup location (for Store version 2.0)	<ul style="list-style-type: none"> In the case of a physical host <code>/opt/jplpc/agtm/store/instance-name/partial/</code> In the case of a logical host <code>environment-directory[#]/jplpc/agtm/store/instance-name/partial/</code>
Import location (for Store version 2.0)	<ul style="list-style-type: none"> In the case of a physical host <code>/opt/jplpc/agtm/store/instance-name/import/</code> In the case of a logical host <code>environment-directory[#]/jplpc/agtm/store/instance-name/import/</code>

[#]
The environment directory resides on a shared disk specified upon the creation of the logical host.

For details, see [3.6.1 Changing the performance data storage location](#).

(c) Specifying the connection-target PFM - Manager for PFM - Agent for Enterprise Applications

On the host where a PFM - Agent is installed, you must specify the PFM - Manager that manages that PFM - Agent. You use the `jpccconf mgrhost define` command to set the connection-target PFM - Manager.

Notes

- There can be only one PFM - Manager as the connection destination even when multiple PFM - Agents are installed on the same host. Different PFM - Managers cannot be specified for the various PFM - Agents.
- If a PFM - Agent and PFM - Manager are installed on the same host, that PFM - Manager on the local host is automatically the connection-target PFM - Manager; you cannot change the connection-target PFM - Manager to some other PFM - Manager.

To specify the connection-target PFM - Manager:

1. Stop all Performance Management programs and services.

Before you start the setup procedure, you must terminate all Performance Management programs and services that are running on the local host. For details about stopping services, see the chapter that describes starting and stopping services in the *JPI/Performance Management User's Guide*.

If a Performance Management program or service remains active during execution of the `jpccconf mgrhost define` command, a message is displayed that asks you to terminate the program.

2. Execute the `jpccconf mgrhost define` command with the host name of the connection-target PFM - Manager specified.

For example, if the connection-target PFM - Manager is on host `host01`, specify the command as follows:

```
jpccconf mgrhost -host host01
```

(d) Specifying the action log output settings

You can log information into the action log when, for example, PFM services start and stop, or when the status of the connection to PFM - Manager changes. The action log stores historical information that is output in conjunction with the alarms for thresholds related to system load and other conditions.

For details about how to set up the action log, see *Appendix J. Outputting Action Log Data*.

(e) Setting up the collection base time

To use the remote monitoring function, you have to set the collection base time for the system log information extraction function and the CCMS alert information extraction function. For details about how to set the environment parameters file and the relevant settings, see *5.3 Environment parameters file* and *6.3 Environment parameters file*.

(f) Setting up a time zone for the SAP system

To use the remote monitoring function, you have to set a time zone (time difference from UTC) for the SAP system, which will be taken into consideration by the system log information extraction function. For details about how to set the environment parameters file and the relevant settings, see *5.3 Environment parameters file* and *6.3 Environment parameters file*.

4.5 Uninstallation and unsetup in a Windows cluster system

This section describes the procedures for uninstalling and canceling the setup of a PFM - Agent for Enterprise Applications that is running in a cluster system.

For details about uninstalling and canceling the setup of PFM - Manager, see the chapter that describes construction and operation in a cluster system in the *JPI/Performance Management User's Guide*.

4.5.1 SAP NetWeaver 7.0 or later (Windows)

(1) Flow of tasks for uninstallation and unsetup of PFM - Agent for Enterprise Applications

The following figure shows the flow of tasks for uninstalling and canceling the setup of a PFM - Agent for Enterprise Applications that is running in a cluster system.

Figure 4–10: Flow of tasks for uninstalling and canceling the setup of a PFM - Agent for Enterprise Applications that is running on a physical host in a cluster system (in Windows)

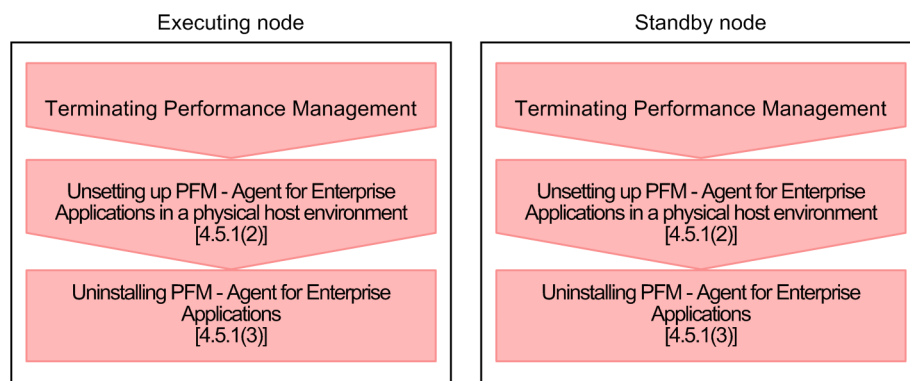

Legend:

-  : Required setup item
- [] : Section to reference

(2) Unsetting up PFM - Agent for Enterprise Applications

This subsection describes how to cancel the setup of PFM - Agent for Enterprise Applications.

(a) Canceling the setup of an instance environment

To cancel the setup of an instance environment, first verify the instance name and then delete the instance environment. You cancel an instance environment at the PFM - Agent host.

Use the `jpccconf inst list` command to verify the instance name, and then use the `jpccconf inst unsetup` command to delete the existing instance environment.

To cancel setup of an instance environment:

1. Find the instance name.

Execute the `jpccconf inst list` command with the service key of PFM - Agent for Enterprise Applications specified.

```
jpccconf inst list -key EAP
```

If the current instance name is `o246bcisd500`, the command displays `o246bcisd500`.

2. If a PFM - Agent service is running in the instance environment, stop the service.

For details about stopping services, see the chapter that describes starting and stopping services in the *JPI/Performance Management User's Guide*.

3. Delete the instance environment.

Execute the `jpccconf inst unsetup` command with the service key and instance name of PFM - Agent for Enterprise Applications specified.

For example, if the instance name of PFM - Agent for Enterprise Applications is `o246bcisd500`, enter the following command:

```
jpccconf inst unsetup -key EAP -inst o246bcisd500
```

If the `jpccconf inst unsetup` command is successful, the folders, service IDs, and Windows services created as the instance environment are deleted.

Note

Canceling the setup of an instance environment does not delete the service information that is displayed by the `jpctool service list` command. For details about how to delete service information, see the section that describes deleting services in the chapter that describes installation and setup in the *JPI/Performance Management Planning and Configuration Guide*.

(3) Uninstalling

Uninstall PFM - Agent for Enterprise Applications.

The uninstallation procedure is the same as for non-cluster systems. For details, see [3.3.3 Uninstallation procedure in Windows](#).

Note

- When you uninstall PFM - Agent for Enterprise Applications, stop all services of the Performance Management programs at the node where PFM - Agent for Enterprise Applications is to be uninstalled.

4.6 Uninstallation and unsetup in a Linux cluster system

4.6.1 SAP NetWeaver 7.0 or later (Linux)

This section describes the procedures for uninstalling and canceling the setup of a PFM - Agent for Enterprise Applications that is running in a cluster system.

For details about how to uninstall and cancel the setup of PFM - Manager, see the chapter that describes configuration and operation in a cluster system in the *JP1/Performance Management User's Guide*.

(1) Flow of tasks for uninstallation and unsetup of PFM - Agent for Enterprise Applications

The following figure shows the flow of tasks for uninstalling and canceling the setup of a PFM - Agent for Enterprise Applications that is running in a cluster system.

Figure 4–11: Flow of tasks for uninstalling and canceling the setup of a PFM - Agent for Enterprise Applications that is running on a physical host in a cluster system (in Linux)

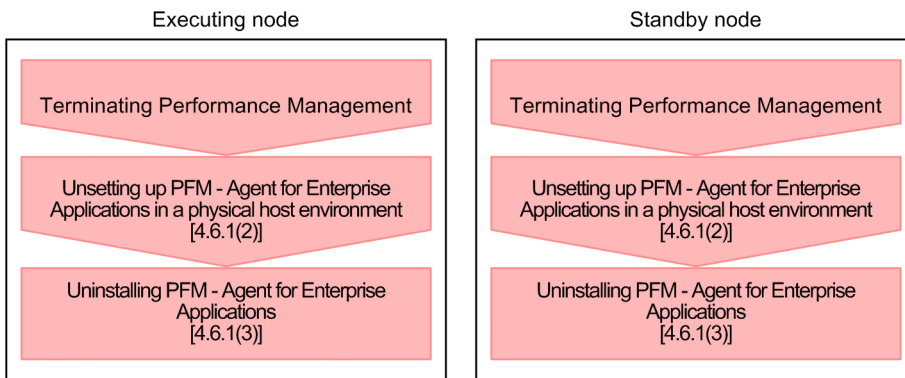

Legend:

-  : Required setup item
- [] : Section to reference

(2) Unsetting up PFM - Agent for Enterprise Applications

This subsection describes how to cancel the setup of PFM - Agent for Enterprise Applications.

(a) Canceling the setup of an instance environment

To cancel the setup of an instance environment, first verify the instance name and then delete the instance environment. You cancel an instance environment at the PFM - Agent host.

Use the `jpccconf inst list` command to verify the instance name, and then use the `jpccconf inst unsetup` command to delete the existing instance environment.

To cancel setup of an instance environment:

1. Find the instance name.

Execute the `jpccconf inst list` command with the service key of PFM - Agent for Enterprise Applications specified.

```
jpccconf inst list -key EAP
```

If the current instance name is `o246bcisd500`, the command displays `o246bcisd500`.

2. If a PFM - Agent service is running in the instance environment, stop the service.

For details about stopping services, see the chapter that describes starting and stopping services in the *JPI/Performance Management User's Guide*.

3. Delete the instance environment.

Execute the `jpccconf inst unsetup` command with the service key and instance name of PFM - Agent for Enterprise Applications specified.

For example, if the instance name of PFM - Agent for Enterprise Applications is `o246bcisd500`, enter the following command:

```
jpccconf inst unsetup -key EAP -inst o246bcisd500
```

If the `jpccconf inst unsetup` command is successful, the directories and service IDs created as the instance environment are deleted.

Note

Canceling the setup of an instance environment does not delete the service information that is displayed by the `jpctool service list` command. For details about how to delete service information, see the section that describes deleting services in the chapter on installation and setup in the *JPI/Performance Management Planning and Configuration Guide*.

(3) Uninstalling

Uninstall PFM - Agent for Enterprise Applications.

The uninstallation procedure is the same as for non-cluster systems. For details, see [3.4.3 Uninstallation procedure in Linux](#).

Note

- When you uninstall PFM - Agent for Enterprise Applications, stop all services of the Performance Management programs at the node where PFM - Agent for Enterprise Applications is to be uninstalled.

4.7 Changing the system configuration of PFM - Agent for Enterprise Applications in a cluster system

You must change the system configuration for PFM - Agent for Enterprise Applications whenever a change occurs in the system, such as a change in a monitored system's network configuration or a change in host names. This section describes how to change the system configuration for PFM - Agent for Enterprise Applications.

- If you change a host name in the SAP system

Change the following item in the setup procedure for updating the instance environment:

- ASHOST

For details about how to change the setting, see [4.8.3 Settings for updating an instance environment in a cluster system](#). If any other settings are changed in the connection-target SAP system, you must also update the instance environment.

- If you change the system configuration of PFM - Agent for Enterprise Applications

When you change the system configuration for PFM - Agent for Enterprise Applications, you must also change the settings for PFM - Manager and PFM - Web Console. For details about how to change the system configuration for Performance Management, see the chapter that describes installation and setup in the *JPI/Performance Management Planning and Configuration Guide*.

4.8 Changing the PFM - Agent for Enterprise Applications operation method in a cluster system

This section describes how to change the PFM - Agent for Enterprise Applications operation method in a cluster system. For details about how to change the operating method for the entire Performance Management, see the chapter that describes installation and setup in the *JPI/Performance Management Planning and Configuration Guide*.

4.8.1 Changing the performance data storage location in a cluster system

The performance data collected by PFM - Agent for Enterprise Applications is managed in the Store database of the Agent Store service of PFM - Agent for Enterprise Applications. For details about how to change the performance data storage location, see [3.6.1 Changing the performance data storage location](#).

4.8.2 Updating the Store version to 2.0 in a cluster system

For details about updating the Store version to 2.0, see [3.6.2 Updating the Store version to 2.0](#).

4.8.3 Settings for updating an instance environment in a cluster system

For details about how to update an instance environment in a cluster system, see [3.6.3 Settings for updating an instance environment](#).

4.9 Backing up and restoring PFM - Agent for Enterprise Applications in a cluster system

For details about backing up and restoring PFM - Agent for Enterprise Applications, see [3.7 Backing up and restoring PFM - Agent for Enterprise Applications](#).

4.10 Notes

You can use any physical host instance to monitor performance data with the following record IDs, because this performance data is recorded for each SAP system:

- PI_BTCP
- PD_ALMX
- PD_SRV
- PI_UMP (depends on the performance monitor that is set)

If monitoring is performed with a single physical host, a failure on that host means monitoring can no longer continue. Therefore, we recommend that you use multiple physical hosts to perform monitoring concurrently.

However, when multiple physical hosts are used to perform monitoring concurrently, multiple alarms might occur for a single event. If this creates a problem, bind the alarm tables to a single physical host and, if a cluster failover occurs, switch the alarm table bindings from this physical host to the physical host where processing is being transferred.

5

Extracting System Log Information

This chapter describes the procedure for extracting system log information with PFM - Agent for Enterprise Applications.

5.1 Overview of the system log information extraction function

You can use PFM - Agent for Enterprise Applications to output periodically to text files the system log information that constitutes a record of the events and errors that occur in the SAP system. The system log information extraction function provided by PFM - Agent for Enterprise Applications can output the following system log information to a text file:

- Message recording time
- Server that recorded the message
- User who recorded the message
- Program that recorded the message
- Message number
- Message

By linking other programs, you can use the system log information in a text file to monitor the status of the SAP system. This section presents an example of status monitoring by linking to JP1/Base and JP1/IM.

The log file trapping function of JP1/Base enables you to convert system log information to JP1 events. By monitoring these JP1 events from JP1/IM, you can monitor the status of the SAP system from JP1/IM.

The following figure shows an example of monitoring the status of an SAP system by linking PFM - Agent for Enterprise Applications with JP1/Base and JP1/IM.

Figure 5–1: Example of monitoring the status of an SAP system by linking with JP1/Base and JP1/IM

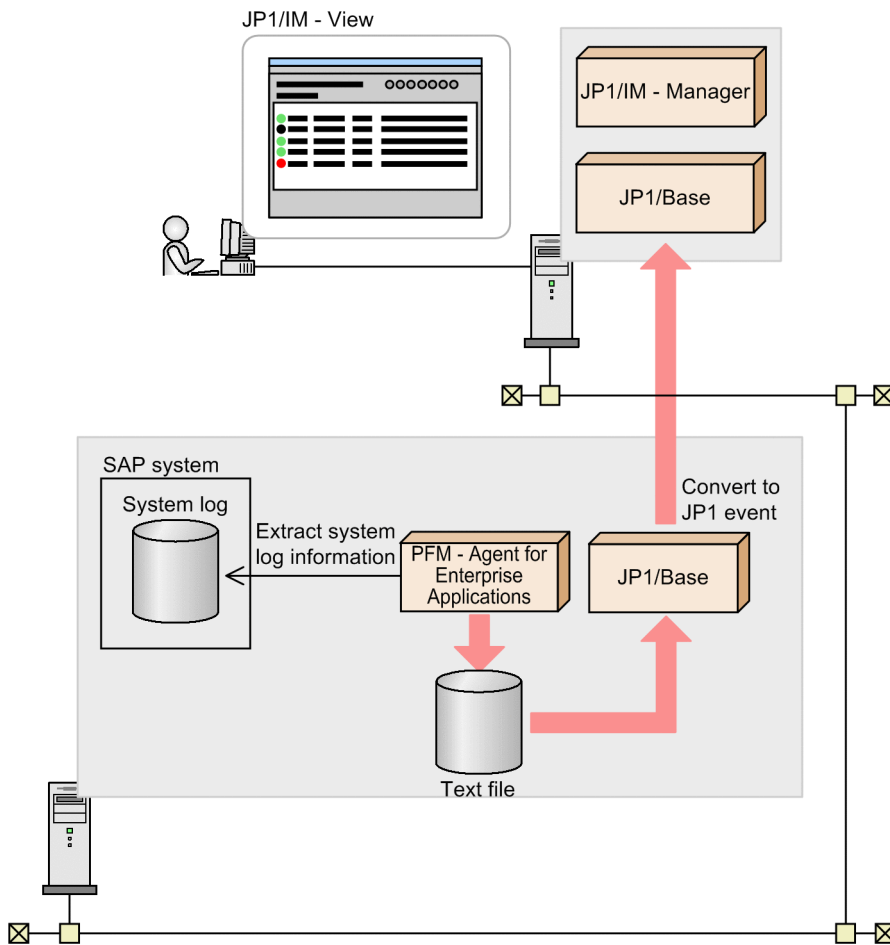

Legend:

 : Flow of system log information

There are two different file formats used by PFM - Agent for Enterprise Applications to store system log information. They are described below.

- WRAP1 format

This file is in wraparound format, which means that data is overwritten when the amount of system log information reaches a specified value. There is a header line of management information at the beginning of the file. Only one WRAP1-format file can be used for storing system log information. If you use the WRAP1 format to monitor system log information, specify the following parameters in the operation definition file:

```
FILETYPE=WRAP1
HEADLINE=1
```

- WRAP2 format

In this file format, when the amount of system log information reaches a specified value, all data in the file is deleted and then new data is written from the beginning of the file. Multiple WRAP2-format files can be used to store system log information. If you use the WRAP2 format to monitor system log information, specify the following parameter in the operation definition file:

```
FILETYPE=WRAP2
```

Note

- To monitor the SAP system log in SAP NetWeaver PI 7.1 or SAP NetWeaver PI 7.1 EHP1 of the prerequisite software on the same unit, you must add the following parameter to the SAP profile. You must also change the SAP system log collection method from HTTP to RFC.

This is because the SAP local system log collection method for the SAP central log function is set to HTTP by default.

```
rslg/central/log/new = 0
```

Once you make this setting, the SAP central function, which is a prerequisite of HTTP, is disabled. Therefore, check the effect on applications that use the SAP central function before the change. Note that this change does not affect PFM - Agent for Enterprise Applications because it does not use the SAP central function.

- The maximum length of a message might be less than 255 bytes depending on the version of the SAP system you use. This occurs because the maximum length of a message returned from a SAP system differs depending on the version of the SAP system.
- When the `jr3slget` command is executed directly to extract system log information while the `TZ` environment variable is defined in the command execution environment, problems might occur such as abnormal command termination or extracted system log information for invalid time ranges. As such, do not define a time zone for the `TZ` environment variable of the command execution environment. The applied time zone will be the one defined in the **Windows Date and Time** Properties dialog box.

5.2 Extracting system log information

This section describes the procedure for extracting the system log information of an SAP system and provides an example of the output.

To extract system log information, you must set up your PFM - Agent for Enterprise Applications to store performance data in the Store database in System Log Monitor Command (PD_SLMX) records. Each time performance data is collected in a System Log Monitor Command (PD_SLMX) record, the system information is then extracted automatically. The previous record collection time is recorded in the timestamp file, and only the system log information that occurs after that time is extracted. The default is for the system log information of the SAP system to be output to the following text file:

OS environment	Host environment	System log information storage file
Windows	Physical host	<ul style="list-style-type: none"> • WRAP1 <i>installation-folder</i>\agtm\agent\<i>instance-name</i>\log\SYSLOG • WRAP2 <i>installation-folder</i>\agtm\agent\<i>instance-name</i>\log\SYSLOG^{#1}
	Logical host	<ul style="list-style-type: none"> • WRAP1 <i>environment-directory</i>^{#2}\jplpc\agtm\agent\<i>instance-name</i>\log\SYSLOG • WRAP2 <i>environment-directory</i>^{#2}\jplpc\agtm\agent\<i>instance-name</i>\log\SYSLOG^{#1}
Linux	Physical host	<ul style="list-style-type: none"> • WRAP1 /opt/jplpc/agtm/agent/<i>instance-name</i>/log/SYSLOG • WRAP2 /opt/jplpc/agtm/agent/<i>instance-name</i>/log/SYSLOG^{#1}
	Logical host	<ul style="list-style-type: none"> • WRAP1 <i>environment-directory</i>^{#2}/jplpc/agtm/agent/<i>instance-name</i>/log/SYSLOG • WRAP2 <i>environment-directory</i>^{#2}/jplpc/agtm/agent/<i>instance-name</i>/log/SYSLOG^{#1}

#1

n indicates a value in the range from 1 through value specified in the NUM label in the EXTRACTFILE section in the environment parameter file.

#2

The environment directory is on the shared disk that was specified when the logical host was created.

The processing result is stored in a System Log Monitor Command (PD_SLMX) record.

For details about the System Log Monitor Command (PD_SLMX) record, see [Chapter 10. Records](#).

The following figure shows the procedure for extracting the system log information of an SAP system.

Figure 5–2: Procedure for extracting system log information

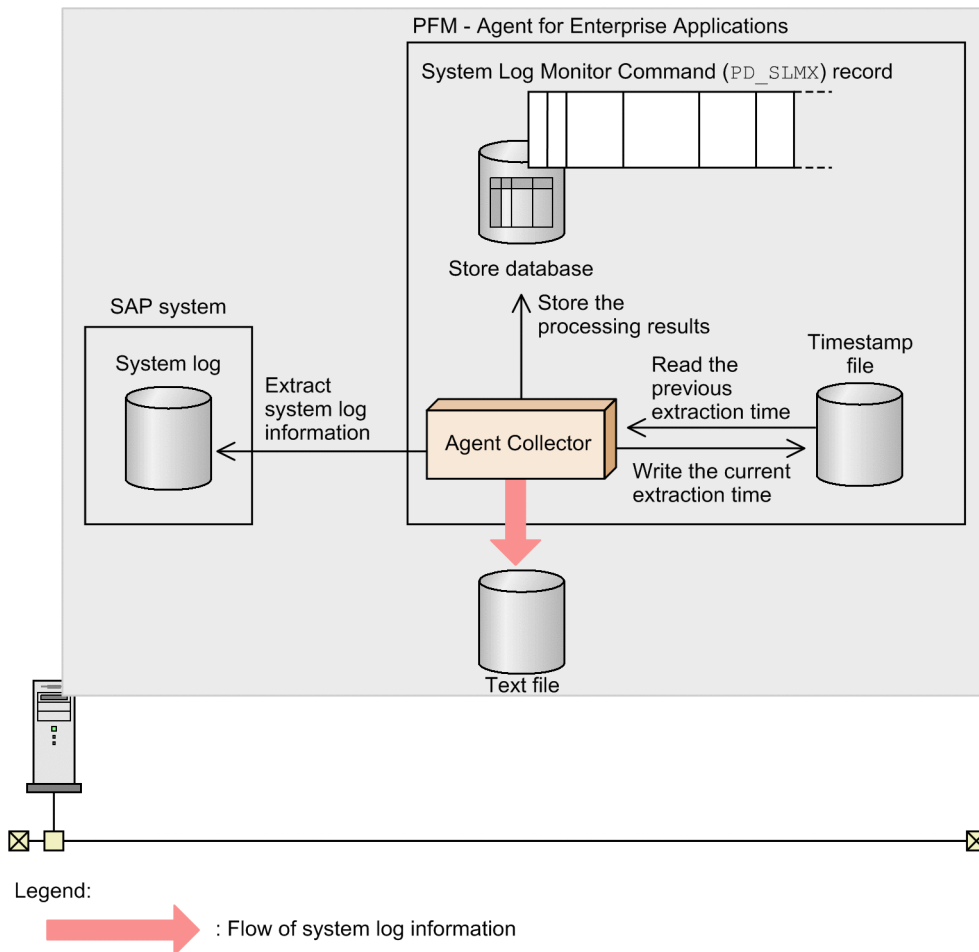

5.2.1 Setup

This section describes the setup procedure for extracting the system log information of an SAP system.

Note

You can change default settings (such as the target file name for system log information) by editing the environment parameters file and then executing this setup. For details about the environment parameters file, see [5.3 Environment parameters file](#).

To set up:

1. Use PFM - Web Console to set up your PFM - Agent for Enterprise Applications so that performance data is stored in System Log Monitor Command (PD_SLMX) records in the Store database.
For details about the setup procedure, see the chapter that describes management of operation monitoring data in the *JPI/Performance Management User's Guide*.

5.2.2 Output example

The following is an example of the system log information output of an SAP system:

```
13:58:04o246bci_SD5_00 SAPSYS SAPMSSY8R49Communication error, CPIC return code 027,  
SAP return code 456  
13:58:04o246bci_SD5_00 SAPSYS SAPMSSY8R64> CPI-C function: CMINIT(SAP)
```

5.3 Environment parameters file

This section describes the environment parameters file.

The environment parameters file is used to specify such information as the file name of the output destination for the system log information. PFM - Agent for Enterprise Applications extracts system log information from the SAP system on the basis of the settings you have specified in the environment parameters file.

You create this environment parameter file as a text file.

5.3.1 Setup procedure

To set up the environment parameters file:

1. Before modifying the environment parameters file, stop collection of System Log Monitor Command (PD_SLMX) records.

Use either of the following methods to stop collection:

- Stop the Agent Collector service
- With the Agent Collector service running, use PFM - Web Console to set up PFM - Agent for Enterprise Applications so that performance data for System Log Monitor Command (PD_SLMX) records is not stored in the Store database.

For details about how to set up the environment parameters file, see the chapter that describes management of operation monitoring data in the *JP1/Performance Management User's Guide*.

2. Open the environment parameters file.

The environment parameters file is as follows:

OS environment	Host environment	Environment parameters file
Windows	Physical host	<code>installation-folder\agtm\agent\instance-name\jr3slget.ini</code>
	Logical host	<code>environment-directory#\jplpc\agtm\agent\instance-name\jr3slget.ini</code>
Linux	Physical host	<code>/opt/jplpc/agtm/agent/instance-name/jr3slget.ini</code>
	Logical host	<code>environment-directory#\jplpc/agtm/agent/instance-name/jr3slget.ini</code>

#

The environment directory is on the shared disk that was specified when the logical host was created.

3. Edit the settings.

The settings that are specified in the environment parameters file are as follows. You can modify the shaded section (for details about the settings, see [5.3.2 Settings](#)):

```

[EXTRACTFILE]
TYPE=WRAP2
NUM=5
SIZE=10240
X2PATH=log\SYSLOG#

[FORMAT]
COLUMN=<TIME>
COLUMN=<INSTANCE>
COLUMN=<USER>
COLUMN=<PROGRAM>
COLUMN=<MSGNO>
COLUMN=<MSGTEXT>

[TRACE]
MSGLOG_LEVEL=2
MSGLOG_SIZE=512
MSGLOG_DIR=log
DATALOG_LEVEL=2
DATALOG_SIZE=512
DATALOG_DIR=log

;[CONNECT]
;LANG=EN
;CODEPAGE=1100

[Option]
SHIFTEXTRACTTIME=10
SAPTIMEZONEOFFSET=0

```

A line beginning with a semicolon (;) is a comment line. The setting on such a line is not enabled. To enable the setting, remove the semicolon.

This is the setting in Windows. In UNIX, it is `log/SYSLOG`.

4. Save the environment parameters file.
5. After modifying the environment parameters file, resume collection of System Log Monitor Command (PD_SLMX) records.

Note

If you change the time zone set for the SAP system (except when such a change is necessitated by the switch between standard time and daylight saving time), you have to delete the file storing the time stamps that are based on the previously set time zone. If the following timestamp file exists, delete it before resuming record collection.

- `installation-folder\agtm\agent\instance-name\log\jr3slget.lasttime`

5.3.2 Settings

Specify the settings in the environment parameters file in the following format:

```

[section]
label=value
label=value
...
...
[section]
label=value
label=value

```

Notes

- Do not specify any unneeded characters, such as spaces at the beginning of a line or before and after an equals sign (=).
- The values specified in *section* and *label* are not case-sensitive.
- A line beginning with a semicolon (;) is treated as a comment.

The following tables describe the contents of each section in the environment parameters file.

(1) EXTRACTFILE section

The EXTRACTFILE section specifies information about the file to which system log information is to be output.

Table 5–1: Values permitted in the EXTRACTFILE section

Label	Description	Permitted values	Default value
TYPE	<p>Format of file for storing system log information:</p> <ul style="list-style-type: none"> • WRAP1 This file is in wraparound format, which means that data is overwritten when the amount of system log information reaches a specified value. • WRAP2 This format consists of the number of files specified in the NUM label. When the amount of data in the first file reaches a specified value, new data is written in the second file from the top after all existing data is deleted from the second file. When all of the files are full, new data is again written in the first file, starting from the top after all existing data is deleted from the first file. <p>If you configure a new environment for PFM - Agent for Enterprise Applications, we recommend that you specify WRAP2.</p> <p>If you want to change the format of storage files after you have started system operations, first stop any products monitoring the storage files, and then delete the storage files and their management files^{#1}.</p>	WRAP1 or WRAP2	<p>WRAP2</p> <p>Note that if there is no TYPE label for reasons such as upgrading from Version 9 or earlier, WRAP1 is assumed.</p>
SIZE	<p>Size of one storage file:</p> <ul style="list-style-type: none"> • 0: 2 GB (the maximum value that can be expressed by a 32-bit signed integer (0x7FFFFFFF)) • 1 to 65535: Wraparound within the specified size (kilobytes) 	0 to 65535	10240 ^{#2}
X2PATH	<ul style="list-style-type: none"> • WRAP1 specified in the TYPE label Specify the path to the storage file that is to be used when storage file output is specified in the -x2 option.^{#1, #3} • WRAP2 specified in the TYPE label 	<ul style="list-style-type: none"> • WRAP1 specified in the TYPE label 1 through 251 bytes of single-byte alphanumeric characters^{#5} 	<ul style="list-style-type: none"> • In Windows: log \SYSLOG • In Linux: log/ SYSLOG

Label	Description	Permitted values	Default value
X2PATH	Specify the storage file that is to be used when storage file output is specified in the <code>-x2</code> option. ^{#3, #4}	<ul style="list-style-type: none"> WRAP2 specified in the TYPE label 1 through 254 bytes of single-byte alphanumeric characters ^{#5}	<ul style="list-style-type: none"> In Windows: <code>log \SYSLOG</code> In Linux: <code>log/ SYSLOG</code>
NUM	Number of files to be written to when using the WRAP2 format. This field is applicable only when WRAP2 is specified in the TYPE label.	2 to 9	5

#1

If the WRAP1 format is used, a management file having the name *storage-file-name*.ofs is created in the same directory as for the storage file.

Example:

If SYSLOG is specified as the storage file name, a management file named SYSLOG.ofs is created in addition to the SYSLOG file.

If you delete the storage file, you must also delete the management file.

#2

For details about the default value that is applied when the product is upgraded from version 09-00 or earlier, see [Appendix H. Migration Steps and Notes on Migration](#).

#3

If you do not use the default storage location, the storage and management files will not be collected when you use the `jpccras` command. Therefore, in the event of a problem, you need to manually collect the storage and management files.

#4

A value in the range specified in the NUM label (default: 1 through 5) is assigned to this value to obtain the file name.

#5

If a relative path is specified, the command's working directory (directory specified in the WORKDIR label in the COMMAND section) is assumed as the current directory. If no working directory is specified, the directory listed below is assumed as the current directory. The environment directory means a directory on the shared disk that was specified when the logical host was created.

In Windows:

Physical host environment: *installation-folder*\agtm\agent\instance-name

Logical host environment: *environment-directory*\jp1pc\agtm\agent\instance-name

In Linux:

Physical host environment: `/opt/jp1pc/agtm/agent/instance-name`

Logical host environment: *environment-directory*/jp1pc/agtm/agent/instance-name

(2) FORMAT section

The FORMAT section specifies the output format of the system log information.

Table 5–2: Values permitted in the FORMAT section

Label	Description	Permitted values	Default values
COLUMN	Output format of system log information	Field ID. For details about the field ID, see <i>Output format and contents</i> in the <code>jr3slget</code> command in Chapter 11. Commands .	Column 1: <TIME> Column 2: <INSTANCE> Column 3: <USER> Column 4: <PROGRAM> Column 5: <MSGNO> Column 6: <MSGTEXT>

(3) TRACE section

The TRACE section specifies information about the message log and data log that store the history of system log information extraction.

Table 5–3: Values permitted in the TRACE section

Label	Description	Permitted values	Default value
MSGLOG_LEVEL	Message log collection level for saving application trace information: <ul style="list-style-type: none"> • 0: Do not collect • 1: Collect only errors • 2: Standard • 3: Details • 4: Debug 	0-4	2
MSGLOG_SIZE	File size for collecting the message log: <ul style="list-style-type: none"> • 0: 2 GB (the maximum value that can be expressed by a 32-bit signed integer (0x7FFFFFFF)) • 1-65535: Wraparound within the specified size (in kilobytes) 	0-65535	512
MSGLOG_DIR	Message log file (jrs1get.log) collection-target directory	(Cannot be changed)	log
DATALOG_LEVEL	Data log collection level for saving various types of data information for applications: <ul style="list-style-type: none"> • 0: Do not collect • 1: Collect only errors • 2: Standard • 3: Details • 4: Debug 	0-4	2
DATALOG_SIZE	File size for collecting the data log: <ul style="list-style-type: none"> • 0: 2 GB (the maximum value that can be expressed by a 32-bit signed integer (0x7FFFFFFF)) • 1-65535: Wraparound within the specified size (in kilobytes) 	0-65535	512
DATALOG_DIR	Data log file (jrs1get.dat) collection-target directory	(Cannot be changed)	log

(4) CONNECT section

The CONNECT section specifies information needed to establish RFC connection with the SAP system.

Table 5–4: Values permitted in the CONNECT section

Label	Description	Permitted value	Default value
LANG	User language used for connection	Japanese and English are supported. 2-byte ISO ID or 1-byte language key that is used in the SAP system: <ul style="list-style-type: none"> • Japanese: JA or J 	None

Label	Description	Permitted value	Default value
LANG	User language used for connection	<ul style="list-style-type: none"> English: EN or E 	None
CODEPAGE	Code page used to convert character codes in the Unicode version of the SAP system at the destination	Value combined with the language in the LANG label [#]	None

#

Set the LANG and CODEPAGE labels in the applicable combination shown below. If any other combination of language and code page is specified, an encoding error might occur in the information acquired from the SAP system.

Table 5–5: Combination of language and code page specifications

Connection-target SAP system	Connection language	Language (LANG)	Code page (CODEPAGE)
Unicode version	Japanese	JA	8000
	English	EN	No need to specify. If you specify a code page, specify 1100.
Non-Unicode version	Japanese	JA	No need to specify. If you specify a code page, specify 8000.
	English	EN	No need to specify. If you specify a code page, specify 1100.

If you omit specification of the LANG label, the user language defined in the connection-target system is assumed.

If you omit specification of the CODEPAGE label, the default code page in the connection-target system is assumed.

(5) Option section

The Option section specifies information that determines the base point for system log extraction.

You can set a time zone for the SAP system by editing the SAPTIMEZONEOFFSET setting in the Option section of the environment parameters file to which the system log information extraction function refers. By editing the SAPTIMEZONEOFFSET setting, you can correctly extract system log information even when the host on which PFM - Agent for Enterprise Applications is running and the SAP system use different time zones. If you do not set a label in this section, the default value is used.

For details about the recommended collection base time for remote monitoring, see [8.1 Notes on the collection base time](#). For details about the precautions to be observed when setting a time zone for the SAP system, see [8.2 Notes on the SAP system time zone](#).

Table 5–6: Values permitted in the Option section

Label	Description	Permitted value	Default value
SHIFTEXTTRACTTIME ^{#1}	The collection base time (units: seconds) that determines the base point for extracting system log information. Relative to the time at which to perform the collection, specify a value that indicates the amount of time by which to shift the time period (defined by two time points) for which to extract system log information.	0-600	5
SAPTIMEZONEOFFSET ^{#2}	When the host on which PFM - Agent for Enterprise Applications is running and the SAP system use different time zones (including the case where one adopts daylight saving time while the other does not), set a	-1440-+1440 ^{#3}	Time zone of the host on which PFM - Agent for Enterprise Applications is running.

Label	Description	Permitted value	Default value
SAPTIMEZONEOFFSET#2	time difference between the SAP system time zone and UTC (units: minutes).	-1440-+1440#3	For example, when PFM - Agent for Enterprise Applications uses JST (UTC+9) as the time zone, +540 is set.

#1

When you are to specify 0 or a greater value, you can omit the plus sign (+).

#2

If, due to the processing delay in the SAP system, the saved system log information does not correctly reflect the actual time at which it has arisen, set a value greater than the default value for this label.

#3

Set this label only when the host on which PFM - Agent is running and the one on which the monitored SAP system is running use different time zones in an environment where the remote monitoring function is used.

The following examples show how to set the collection base time and the time zone:

- When 10 seconds is to be set as the collection base time

```
[Option]
SHIFTEXTRACTTIME=10
```

- When UTC (UTC+0) is set as the SAP system time zone and standard time is used

```
[Option]
SAPTIMEZONEOFFSET=0
```

- When EST (UTC-5) is set as the SAP system time zone and daylight saving time (+1 hour) is used

```
[Option]
SAPTIMEZONEOFFSET=-240
```

5.4 Using a command to extract system log information

You can also extract the system log information of an SAP system by executing the `jr3slget` command manually or by having another program execute it automatically. This section describes the use of the `jr3slget` command to extract system log information.

5.4.1 Before executing the command

You should check the following items before you execute the `jr3slget` command to extract the system log information of an SAP system:

- Settings in the environment parameters file

This is not the same environment parameters file that is used to extract system log information using System Log Monitor Command (PD_SLMX) records. For details about this environment parameters file, which is used in conjunction with extracting system log information by command execution, see [5.4.3 Environment parameters file for extracting system log information by command execution](#).

- Command execution environment

Check that:

- There are no errors in the network settings
- The SAP system is running
- The SAP system is ready to accept RFC requests

5.4.2 Using the command to extract system log information

When you execute the `jr3slget` command (either manually or automatically from another program), you can select the system log information to be extracted from the SAP system as follows:

- Extract all system log information that has been output so far on the day the command is executed.
- Extract only the system log information that has been output since the last time the command was executed.

For details about the `jr3slget` command, see [jr3slget](#).

Note

If you specify values for the same parameter in both the environment parameters file and the `jr3slget` command, the value in the command takes effect.

The two extraction methods are explained below.

(1) Extracting all system log information that has been output so far on the day the command is executed

The following command specification extracts all system log information that has been output so far on the day the command is executed (this example assumes that values have been defined for the `CONNECT` and `TARGET` sections in the environment parameters file):

```
jr3slget
```

(2) Extracting only the system log information that has been output since the last time the command was executed

To extract only the system log information that has been output since the last time the command was executed, execute the command with the timestamp file specified in the `-lasttime` option. The timestamp file contains a history of the execution dates and times for the `jr3slget` command. When you execute the command repeatedly specifying the same timestamp file, you extract consecutive system log information without any duplication.

Note

If the timestamp file specified in the `-lasttime` option does not exist when the command is executed for the first time, the command creates a new timestamp file, in which case no system log information is reported.

The following command specification extracts only the system log information that has been output since the last time the command was executed (this example assumes that values have been defined for the `CONNECT` and `TARGET` sections in the environment parameters file):

```
jr3slget -lasttime sltimestamp.txt
```

5.4.3 Environment parameters file for extracting system log information by command execution

If you specify an environment parameters file as an argument in the `jr3slget` command, the command extracts the system log information of the SAP system based on the settings in the file.

You create this environment parameter file as a text file.

(1) Setup procedure

To set up the environment parameters file:

1. Before you edit the environment parameters file, make sure that the `jr3slget` command is not running.
2. To create a new environment parameters file, copy the sample environment parameters file under the name `jr3slget.ini`.

This `jr3slget.ini` becomes the default environment parameters file. The sample environment parameters file is as follows:

In Windows:

```
installation-folder\agtm\evtrap\jr3slget.ini.sample
```

In Linux:

```
/opt/jp1pc/agtm/evtrap/jr3slget.ini.sample
```

3. Open the `jr3slget.ini` file.
4. Edit the settings.

The settings in the default environment parameters file are as follows; for details about the settings, see (2) [Settings](#):

```

[CONNECT]
ASHOST=localhost
SYSNR=00
CLIENT=000
USER=CPIC
PASSWD=ADMIN
;LANG=EN
;CODEPAGE=1100

[COMMAND]
;WORKDIR=

[TRACE]
MSGLOG_LEVEL=2
MSGLOG_SIZE=512
MSGLOG_DIR=.
DATALOG_LEVEL=2
DATALOG_SIZE=512
DATALOG_DIR=.

[TARGET]
;SERVER=

[FORMAT]
;COLUMN=<TIME>
;COLUMN=<INSTANCE>
;COLUMN=<USER>
;COLUMN=<PROGRAM>
;COLUMN=<MSGNO>
;COLUMN=<MSGTEXT>

[EXTRACTFILE]
TYPE=WRAP2
NUM=5
SIZE=10240
X2PATH=SYSLOG

```

In the case of an item that begins with a semicolon (;), the setting is disabled by default, because the semicolon indicates that it is a comment line. To enable the setting, remove the semicolon.

5. Save the environment parameters file.

By specifying the `-cnf` option in the `jr3slget` command, you can extract the system log information of the SAP system based on the settings in the environment parameters file.

(2) Settings

Specify the settings in the environment parameters file in the following format:

```

[section]
label=value
label=value
...
...
[section]
label=value
label=value

```

Notes

- Do not specify any unneeded characters, such as spaces at the beginning of a line or before and after an equals sign (=).

- The values specified in *section* and *label* are not case-sensitive.
- A line beginning with a semicolon (;) is treated as a comment.

The following tables describe the contents of each section in the environment parameters file. In a table, the *Argument* column indicates the argument that is specified in the `jr3slget` command, if applicable. N/A means that the item cannot be specified with the command.

(a) CONNECT section

The `CONNECT` section specifies information needed to establish RFC connection with the SAP system at the time of command execution.

Table 5–7: Values permitted in the `CONNECT` section

Label	Description	Permitted values	Default value	Argument
ASHOST	Host name of the connection-target application server (which can be verified by transaction code SM51)	1-100 single-byte alphanumeric characters in one of the following formats: <ul style="list-style-type: none"> • Host name specified in the <code>hosts</code> file • IP address • SAP router address 	localhost	-h
SYSNR	System number that can be identified by the connection-target application server host	0-99	00	-s
CLIENT	User's client name used for establishing connection	0-999	000	-c
USER	User name used for establishing connection ^{#1}	1-12 single-byte alphanumeric characters	CPIC	-u
PASSWD	User's password used for establishing connection ^{#2}	1-8 single-byte characters ^{#3}	ADMIN	-p
PASSWD2	User's extended password used for establishing connection ^{#2}	1-40 single-byte characters ^{#3}	ADMIN	-p2
LANG	User language used for connection	Japanese and English are supported. 2-byte ISO ID or 1-byte language key that is used in the SAP system: <ul style="list-style-type: none"> • Japanese: JA or J • English: EN or E 	None	-l
CODEPAGE	Code page used to convert character codes in the Unicode version of the SAP system at the destination	Value combined with the language in the <code>LANG</code> label ^{#4}	None	-codepage

#1
The user specified in this label must have already been granted the following authorizations:

Table 5–8: Authorizations required by the user to establish RFC connection with function modules (`S_RFC`)

Authorization	Description	Value
RFC_TYPE	Type of RFC object to be protected	FUGR (function group)

Authorization	Description	Value
RFC_NAME	RFC name to be protected	*
ACTVT	Activity	16 (execution)

Table 5–9: Authorizations required for use of external management interfaces (S_XMI_PROD)

Authorization	Description	Value
EXTCOMPANY	Company name of the external management tool	HITACHI
EXTPRODUCT	Program name of the external management tool	JP1
INTERFACE	Interface ID	XAL

You can use the following user types for the user specified in this label:

- Dialog
- System
- Communication
- Service

#2

Specify the `PASSWD` label if the SAP system is applying conventional password rules. Specify the `PASSWD2` label if the SAP system is applying extended password rules. The `PASSWD` and `PASSWD2` labels are mutually exclusive.

#3

A user's password or extended password that is used for establishing connection must consist of single-byte numeric characters (from 0 to 9), single-byte alphabetic characters (from a to z, A to Z), and the following single-byte symbols:

!, @, \$, %, &, /, (,), =, ?, ', `*, +, ~, #, -, _, ., :, {, [,], }, <, >, |

#4

Set the `LANG` and `CODEPAGE` labels in the applicable combination shown below. If any other combination of language and code page is specified, an encoding error might occur in the information acquired from the SAP system.

Table 5–10: Combination of language and code page specifications

Connection-target SAP system	Connection language	Language (LANG)	Code page (CODEPAGE)
Unicode version	Japanese	JA	8000
	English	EN	No need to specify. If you specify a code page, specify 1100.
Non-Unicode version	Japanese	JA	No need to specify. If you specify a code page, specify 8000.
	English	EN	No need to specify. If you specify a code page, specify 1100.

If you omit specification of the `LANG` label, the user language defined in the connection-target system is assumed.

If you omit specification of the `CODEPAGE` label, the default code page in the connection-target system is assumed.

(b) COMMAND section

The `COMMAND` section specifies information about the work directory for the `jr3slget` command.

Table 5–11: Values permitted in the COMMAND section

Label	Description	Permitted values	Default value	Argument
WORKDIR	Work directory for the command	1 to 255 single-byte alphanumeric characters. If a relative path is specified, it is treated as the path relative to the current directory.	Current directory	N/A

(c) TRACE section

The TRACE section specifies information about the message log and data log that store the history of system log information extraction.

Table 5–12: Values permitted in the TRACE section

Label	Description	Permitted values	Default value	Argument
MSGLOG_LEVEL	Message log collection level for saving application trace information: <ul style="list-style-type: none"> 0: Do not collect 1: Collect only errors 2: Standard 3: Details 4: Debug 	0-4	2	N/A
MSGLOG_SIZE	File size for collecting the message log: <ul style="list-style-type: none"> 0: 2 GB (the maximum value that can be expressed by a 32-bit signed integer (0x7FFFFFFF)) 1-65535: Wraparound within the specified size (in kilobytes) 	0-65535	512	N/A
MSGLOG_DIR	Message log file (<code>jr3slget.log</code>) collection-target directory	1-255 single-byte alphanumeric characters. The total length, including file name <code>jr3slget.log</code> , must not exceed 255 bytes. If a relative path is specified, it is treated as the path relative to the work directory for the command.	Work directory for the command (or the current directory if it has not been changed by the WORKDIR label in the COMMAND section)	N/A
DATALOG_LEVEL	Data log collection level for saving various types of data information for applications: <ul style="list-style-type: none"> 0: Do not collect 1: Collect only errors 2: Standard 3: Details 4: Debug 	0-4	2	N/A
DATALOG_SIZE	File size for collecting the data log: <ul style="list-style-type: none"> 0: 2 GB (the maximum value that can be expressed by a 32-bit signed integer (0x7FFFFFFF)) 1-65535: Wraparound within the specified size (in kilobytes) 	0-65535	512	N/A

Label	Description	Permitted values	Default value	Argument
DATALOG_DIRECTORY	Data log file (jr3slget.dat) collection-target directory	1-255 single-byte alphanumeric characters. The total length, including file name jr3slget.dat, must not exceed 255 bytes. If a relative path is specified, it is treated as the path relative to the work directory for the command.	Work directory for the command (or the current directory if it has not been changed by the WORKDIR label in the COMMAND section)	N/A

(d) TARGET section

The TARGET section specifies information that identifies the system log information to be extracted.

Table 5–13: Values permitted in the TARGET section

Label	Description	Permitted values	Default value	Argument
SERVER	SAP instance name (the SAP instance name that has a dialog service, and which can be verified by transaction code SM51)	1 to 20 single-byte alphanumeric characters	None	-server

(e) FORMAT section

The FORMAT section specifies the output format of the system log information.

Table 5–14: Values permitted in the FORMAT section

Label	Description	Permitted values	Default values	Argument
COLUMN	Output format of system log information	Field ID. For details about the field ID, see <i>Output format and contents</i> in the jr3slget command in <i>11. Commands</i> .	Column 1: <TIME> Column 2: <INSTANCE> Column 3: <USER> Column 4: <PROGRAM> Column 5: <MSGNO> Column 6: <MSGTEXT>	N/A

(f) EXTRACTFILE section

The EXTRACTFILE section specifies information about the output file for the system log information.

Table 5–15: Values permitted in the EXTRACTFILE section

Label	Description	Permitted values	Default value
TYPE	Format of file for storing system log information: <ul style="list-style-type: none"> WRAP1 This file is in wraparound format, which means that data is overwritten when the amount of system log information reaches a specified value. WRAP2 This format consists of the number of files specified in the NUM label. When the amount of data in the first file reaches a specified value, new data is written in the 	WRAP1 or WRAP2	WRAP1

Label	Description	Permitted values	Default value
TYPE	<p>second file from the top after all existing data is deleted from the second file.</p> <p>When all of the files are full, new data is again written in the first file, starting from the top after all existing data is deleted from the first file.</p> <p>If you configure a new environment for PFM - Agent for Enterprise Applications, we recommend that you specify WRAP2.</p> <p>If you want to change the format of storage files after you have started system operations, first stop any products monitoring the storage files, and then delete the storage files and their management files^{#1}.</p>	WRAP1 or WRAP2	WRAP1
SIZE	<p>Size of one storage file:</p> <ul style="list-style-type: none"> 0: 2 GB (the maximum value that can be expressed by a 32-bit signed integer (0x7FFFFFFF)) 1 to 65535: Wraparound within the specified size (kilobytes) 	0 to 65535	10240 ^{#2}
X2PATH	<ul style="list-style-type: none"> WRAP1 specified in the TYPE label Specify the path to the storage file that is to be used when storage file output is specified in the -x2 option.^{#1, #3} WRAP2 specified in the TYPE label Specify the storage file that is to be used when storage file output is specified in the -x2 option.^{#3, #4} 	<ul style="list-style-type: none"> WRAP1 specified in the TYPE label 1 through 251 bytes of single-byte alphanumeric characters^{#5} WRAP2 specified in the TYPE label 1 through 254 bytes of single-byte alphanumeric characters^{#5} 	--
NUM	<p>Number of files to be written to when using the WRAP2 format.</p> <p>This field is applicable only when WRAP2 is specified in the TYPE label.</p>	2 to 9	5

Legend:

--: Not applicable

#1

If the WRAP1 format is used, a management file having the name *storage-file-name*.ofs is created in the same directory as for the storage file.

Example:

If SYSLOG is specified as the storage file name, a management file named SYSLOG.ofs is created in addition to the SYSLOG file.

If you delete the storage file, you must also delete the management file.

#2

For details about the default value that is applied when the product is upgraded from version 09-00 or earlier, see [Appendix H. Migration Steps and Notes on Migration](#).

#3

If you do not use the default storage location, the storage and management files will not be collected when you use the jpcras command. Therefore, in the event of a problem, you need to manually collect the storage and management files.

#4

A value in the range specified in the NUM label (default: 1 through 5) is assigned to this value to obtain the file name.

#5

If a relative path is specified, the command's working directory (directory specified in the `WORKDIR` label in the `COMMAND` section) is assumed as the current directory. If no working directory is specified, the directory listed below is assumed as the current directory. The environment directory means a directory on the shared disk that was specified when the logical host was created.

In Windows:

Physical host environment: *installation-folder\agtm\agent\instance-name*

Logical host environment: *environment-directory\jplpc\agtm\agent\instance-name*

In Linux:

Physical host environment: */opt/jplpc/agtm/agent/instance-name*

Logical host environment: *environment-directory/jplpc/agtm/agent/instance-name*

(g) Option section

The `Option` section specifies information that determines the base point for system log extraction.

For details about the `Option` section, see [5.3.2 \(5\) Option section](#).

(3) Notes

If you change the time zone set for the SAP system (except when such a change is necessitated by the switch between standard time and daylight saving time), you have to delete the file storing the time stamps that are based on the previously set time zone. If the timestamp file specified for the `-lasttime` option of the `jr3slget` command exists, delete it before resuming command execution.

6

Extracting CCMS Alert Information

This chapter describes the procedure for extracting CCMS alert information with PFM - Agent for Enterprise Applications.

6.1 Overview of the CCMS alert information extraction function

You can use PFM - Agent for Enterprise Applications to output periodically to text files the warning (alert information) that occurs on Alert Monitor in the computer center management system (CCMS). The CCMS alert information extraction function provided by PFM - Agent for Enterprise Applications can output the following CCMS alert information to a text file:

- Alert ID
- ID of MTE associated with the alert
- Severity level of the alert
- General properties
- Message

By linking other programs, you can use the CCMS alert information in a text file to monitor for error information in the SAP system. This section presents an example of error monitoring by linking to JP1/Base and JP1/IM.

The log file trapping function of JP1/Base enables you to convert CCMS alert information to JP1 events. By monitoring these JP1 events from JP1/IM, you can monitor error information in the SAP system from JP1/IM.

The following figure shows an example of monitoring an SAP system for errors by linking PFM - Agent for Enterprise Applications with JP1/Base and JP1/IM.

Figure 6–1: Example of monitoring an SAP system for errors by linking with JP1/Base and JP1/IM

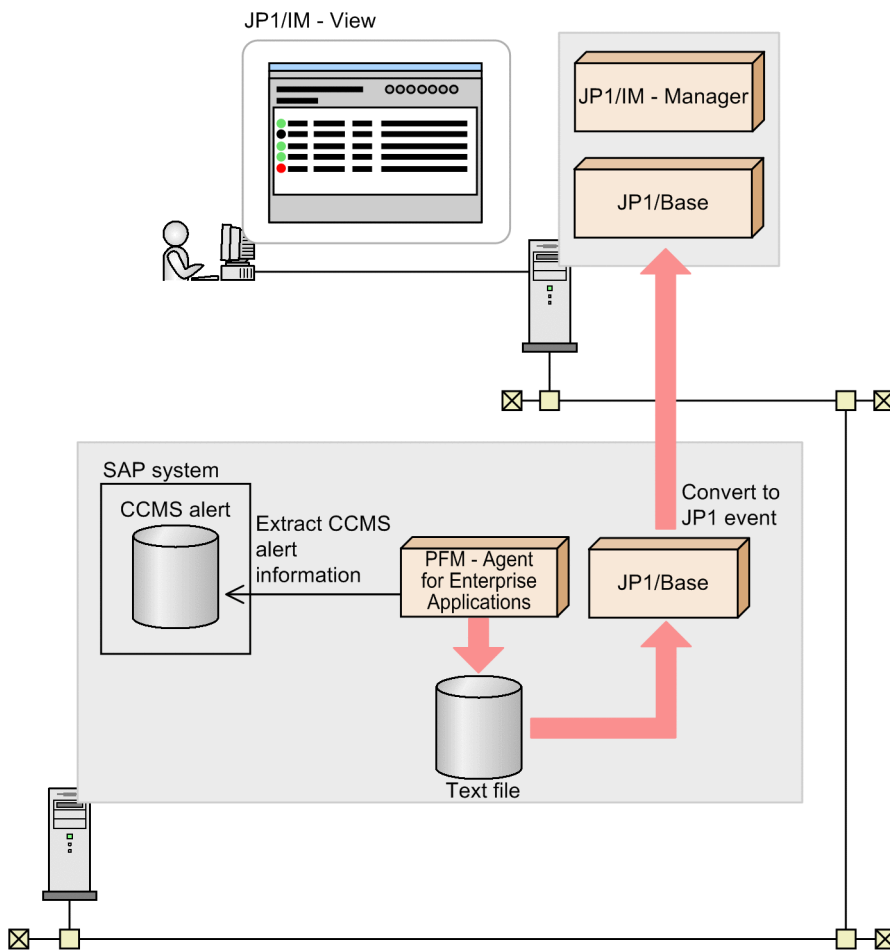

Legend:

 : Flow of CCMS alert information

There are two different file formats used by PFM - Agent for Enterprise Applications to store CCMS Alert Information. They are described below.

- WRAP1 format

This file is in wraparound format, which means that data is overwritten when the amount of CCMS Alert Information reaches a specified value. There is a header line of management information at the beginning of the file. Only one WRAP1-format file can be used for storing CCMS Alert Information. If you use the WRAP1 format to monitor CCMS Alert Information, specify the following parameters in the operation definition file:

```
FILETYPE=WRAP1
HEADLINE=1
```

- WRAP2 format

In this file format, when the amount of CCMS Alert Information reaches a specified value, all data in the file is deleted and then new data is written from the beginning of the file. Multiple WRAP2-format files can be used to store CCMS Alert Information. If you use the WRAP2 format to monitor CCMS Alert Information, specify the following parameter in the operation definition file:

```
FILETYPE=WRAP2
```

6.2 Extracting CCMS alert information

This section describes the procedure for extracting the CCMS alert information of an SAP system and provides an example of the output.

To extract CCMS alert information, you must set up your PFM - Agent for Enterprise Applications to store performance data in the Store database in CCMS Alert Monitor Command (PD_ALMX) records. Each time performance data is collected in CCMS Alert Monitor Command (PD_ALMX) record, the CCMS alert information is then extracted automatically. The previous record collection time is recorded in the timestamp file and only the CCMS alert information that occurs after that time is extracted. The default is for the CCMS alert information of the SAP system to be output to the following text file:

OS environment	Host environment	CCMS alert information storage file
Windows	Physical host	<ul style="list-style-type: none"> • WRAP1 <i>installation-folder</i>\agtm\agent\<i>instance-name</i>\log\ALERT • WRAP2 <i>installation-folder</i>\agtm\agent\<i>instance-name</i>\log\ALERTn^{#1}
	Logical host	<ul style="list-style-type: none"> • WRAP1 <i>environment-directory</i>^{#2}\jplpc\agtm\agent\<i>instance-name</i>\log\ALERT • WRAP2 <i>environment-directory</i>^{#2}\jplpc\agtm\agent\<i>instance-name</i>\log\ALERTn^{#1}
Linux	Physical host	<ul style="list-style-type: none"> • WRAP1 /opt/jplpc/agtm/agent/<i>instance-name</i>/log/ALERT • WRAP2 /opt/jplpc/agtm/agent/<i>instance-name</i>/log/ALERTn^{#1}
	Logical host	<ul style="list-style-type: none"> • WRAP1 <i>environment-directory</i>^{#2}/jplpc/agtm/agent/<i>instance-name</i>/log/ALERT • WRAP2 <i>environment-directory</i>^{#2}/jplpc/agtm/agent/<i>instance-name</i>/log/ALERTn^{#1}

#1

n indicates a value in the range from 1 through value specified in the NUM label in the EXTRACTFILE section in the environment parameter file.

#2

The environment directory is on the shared disk that was specified when the logical host was created.

The processing result is stored in a CCMS Alert Monitor Command (PD_ALMX) record.

For details about the CCMS Alert Monitor Command (PD_ALMX) record, see [Chapter 10. Records](#).

The following figure shows the procedure for extracting the CCMS alert information of an SAP system:

Figure 6–2: Procedure for extracting CCMS alert information

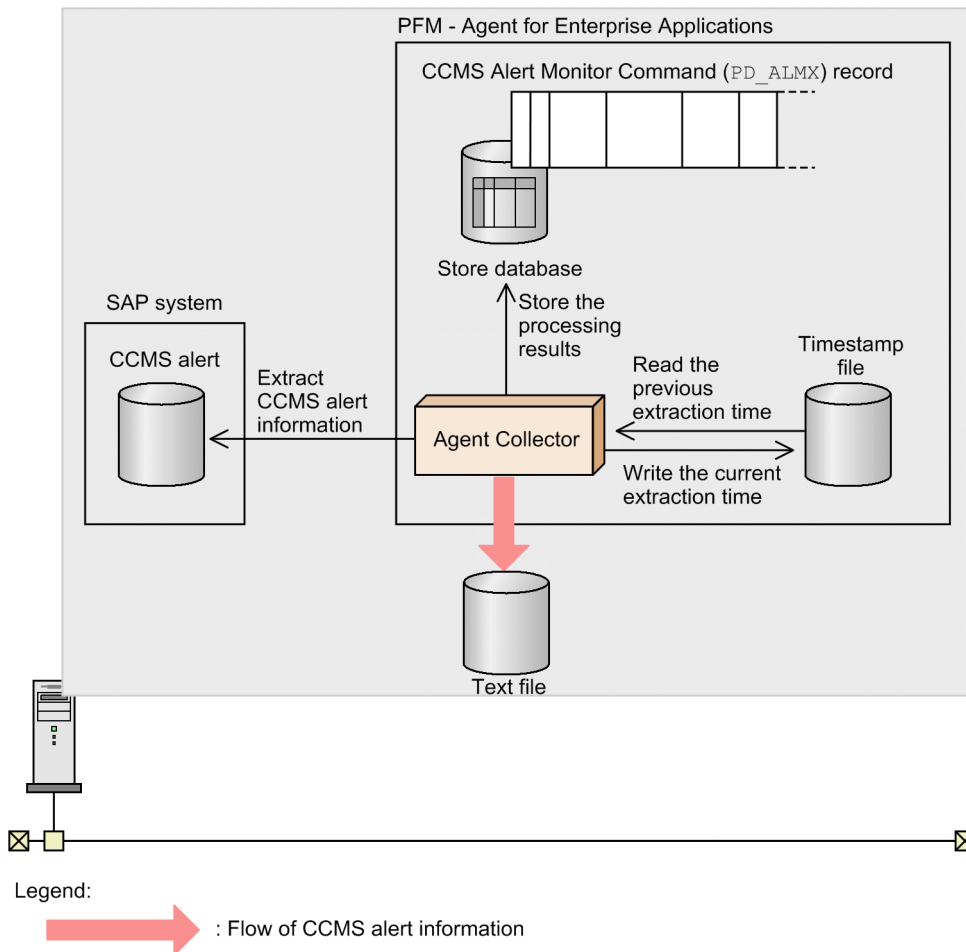

6.2.1 Setup

This section describes the setup procedure for extracting the CCMS alert information of an SAP system.

Note

You can change default settings (such as the target file name for CCMS alert information) by editing the environment parameters file and then executing this setup. For details about the environment parameters file, see [6.3 Environment parameters file](#).

To set up:

1. Use PFM - Web Console to set up your PFM - Agent for Enterprise Applications so that performance data is stored in CCMS Alert Monitor Command (PD_ALMX) records in the Store database.

For details about the setup procedure, see the chapter that describes management of operation monitoring data in the *JPI/Performance Management User's Guide*.

6.2.2 Output example

The following is an example of the CCMS alert information output of an SAP system:

20030321171911SD5 o246bci_SD5_00 Background AbortedJobs Job
DBA:CHECKOPT_____@021500/6007 (ID number 02153101) terminated20030321171911SD5
o246bci_SD5_00 GenericKey SpaceUsed 95 % > 90 % 15 min. avg. value over threshold
value

6.3 Environment parameters file

This section describes the environment parameters file.

The environment parameters file is used to specify such information as the file name of the output destination for the CCMS alert information. PFM - Agent for Enterprise Applications extracts CCMS alert information from the SAP system on the basis of the settings you have specified in the environment parameters file.

You create this environment parameter file as a text file.

6.3.1 Setup procedure

To set up an environment parameters file:

1. Before modifying the environment parameters file, stop collection of CCMS Alert Monitor Command (PD_ALMX) records.

Use either of the following methods to stop collection:

- Stop the Agent Collector service
- With the Agent Collector service running, use PFM - Web Console to set up PFM - Agent for Enterprise Applications so that the performance data for the CCMS Alert Monitor Command (PD_ALMX) records is not stored in the Store database.

For details about how to set up the environment parameters file, see the chapter that describes management of operation monitoring data in the *JPI/Performance Management User's Guide*.

2. Open the environment parameters file.

The environment parameters file is as follows:

OS environment	Host environment	Environment parameters file
Windows	Physical host	<i>installation-folder</i> \agtm\agent\ <i>instance-name</i> \jr3alget.ini
	Logical host	<i>environment-directory</i> #\jplpc\agtm\agent\ <i>instance-name</i> \jr3alget.ini
Linux	Physical host	/opt/jplpc/agtm/agent/ <i>instance-name</i> /jr3alget.ini
	Logical host	<i>environment-directory</i> #/jplpc/agtm/agent/ <i>instance-name</i> /jr3alget.ini

#

The environment directory is on the shared disk that was specified when the logical host was created.

3. Edit the settings.

The settings that are specified in the environment parameters file are as follows. You can modify the shaded section (for details about the settings, see [6.3.2 Settings](#)).

```
[TARGET]
MONITOR_SET=SAP CCMS Monitor Templates
MONITOR=Entire System
```

```
[EXTRACTFILE]
TYPE=WRAP2
NUM=5
SIZE=10240
X2PATH=log\ALERT#
```

```
[FORMAT]
COLUMN=<ALERTDATE>
COLUMN=<ALERTTIME>
COLUMN=<MTSYSID>
COLUMN=<MTMCNAME>
COLUMN=<OBJECTNAME>
COLUMN=<FIELDNAME>
COLUMN=<VALUE>
COLUMN=<SEVERITY>
COLUMN=<MSG>
```

```
[TRACE]
MSGLOG_LEVEL=2
MSGLOG_SIZE=512
MSGLOG_DIR=log
DATALOG_LEVEL=2
DATALOG_SIZE=512
DATALOG_DIR=log
```

```
:[CONNECT]
;LANG=EN
;CODEPAGE=1100
```

```
[Option]
SHIFTEXTRACTTIME=10
```

A line beginning with a semicolon (;) is a comment line. The setting on such a line is not enabled. To enable the setting, remove the semicolon.

This is the setting in Windows. In UNIX, it is `log/ALERT`.

4. Save the environment parameters file.
5. After modifying the environment parameters file, resume collection of CCMS Alert Monitor Command (PD_ALMX) records.

6.3.2 Settings

Specify the settings in the environment parameters file in the following format:

```
[section]
label=value
label=value
...
...
[section]
label=value
label=value
```

Notes

- Do not specify any unneeded characters, such as spaces at the beginning of a line or before and after an equals sign (=).
- The values specified in *section* and *label* are not case-sensitive.
- A line beginning with a semicolon (;) is treated as a comment.

The following tables describe the contents of each section in the environment parameters file.

(1) TARGET section

The TARGET section specifies information that identifies the CCMS alert information to be extracted.

Table 6–1: Values permitted in the TARGET section

Label	Description	Permitted values	Default value
MONITOR_SET #	Monitor set name (name displayed as CCMS monitor set on the SAP system Alert Monitor (transaction code RZ20))	1 to 60 single-byte alphanumeric characters	SAP CCMS Monitor Templates
MONITOR#	Monitor name (name displayed in the tree of the CCMS monitor set on the SAP system Alert Monitor (transaction code RZ20))	1 to 60 single-byte alphanumeric characters	Entire System

#

Specifying multiple targets is not permitted. To monitor multiple monitors, use the CCMS function of the SAP system to combine all the targets to be monitored into a single monitor, and then monitor this monitor from PFM - Agent for Enterprise Applications.

(2) EXTRACTFILE section

The EXTRACTFILE section specifies information about the file to which CCMS alert information is to be output.

Table 6–2: Values permitted in the EXTRACTFILE section

Label	Description	Permitted values	Default value
TYPE	<p>Format of file for storing CCMS Alert Information:</p> <ul style="list-style-type: none">• WRAP1 This file is in wraparound format, which means that data is overwritten when the amount of CCMS Alert Information reaches a specified value.• WRAP2 This format consists of the number of files specified in the NUM label. When the amount of data in the first file reaches a specified value, new data is written in the second file, starting at the top, after all existing data is deleted from the second file. When all the files are full, new data is again written in the first file, starting at	WRAP1 or WRAP2	WRAP2 Note that if there is no TYPE label for reasons such as upgrading from Version 9 or earlier, WRAP1 is assumed.

Label	Description	Permitted values	Default value
TYPE	<p>the top, after all existing data is deleted from the first file.</p> <p>If you configure a new environment for PFM - Agent for Enterprise Applications, we recommend that you specify WRAP2.</p> <p>If you want to change the format of storage files after you have started system operations, first stop any products monitoring the storage files, and then delete the storage files and their management files^{#1}.</p>	WRAP1 or WRAP2	WRAP2 Note that if there is no TYPE label for reasons such as upgrading from Version 9 or earlier, WRAP1 is assumed.
SIZE	<p>Size of one storage file:</p> <ul style="list-style-type: none"> 0: 2 GB (the maximum value that can be expressed by a 32-bit signed integer (0x7FFFFFFF)) 1 to 65535: Wraparound within the specified size (kilobytes) 	0 to 65535	10240 ^{#2}
X2PATH	<ul style="list-style-type: none"> WRAP1 specified in the TYPE label Specify the path of the storage file that is to be used when storage file output is specified in the -x2 option.^{#1, #3} WRAP2 specified in the TYPE label Specify the storage file that is to be used when storage file output is specified in the -x2 option.^{#3, #4} 	<ul style="list-style-type: none"> WRAP1 specified in the TYPE label 1 through 251 bytes of single-byte alphanumeric characters^{#5} WRAP2 specified in the TYPE label 1 through 254 bytes of single-byte alphanumeric characters^{#5} 	<ul style="list-style-type: none"> In Windows: log\ALERT In Linux: log/ALERT
NUM	<p>Number of files to be stored in the WRAP2 format.</p> <p>This is applicable only when WRAP2 is specified in the TYPE label.</p>	2 to 9	5

#1

If the WRAP1 format is used, a management file having the name *storage-file-name.ofs* is created in the same directory as for the storage file.

Example:

If ALERT is specified as the storage file name, a management file named *ALERT.ofs* is created in addition to the ALERT file.

If you delete the storage file, you must also delete the management file.

#2

For details about the default value that is used when the product is upgraded from version 09-00 or earlier, see [Appendix H. Migration Steps and Notes on Migration](#).

#3

If you do not use the default storage location, the storage and management files will not be collected when using the *jpccras* command. Therefore, in the event of a problem, you need to manually collect the storage and management files.

#4

A value in the range specified in the NUM label (default: 1 through 5) is assigned to this value to obtain the file name.

#5

If a relative path is specified, the command's working directory (directory specified in the WORKDIR label in the COMMAND section) is assumed as the current directory. If no working directory is specified, the directory listed below is assumed as the current directory. The environment directory means a directory on the shared disk that was specified when the logical host was created.

In Windows:

Physical host environment: *installation-folder\agtm\agent\instance-name*

Logical host environment: *environment-directory\jplpc\agtm\agent\instance-name*

In Linux:

Physical host environment: `/opt/jp1pc/agt/agent/instance-name`

Logical host environment: `environment-directory/jp1pc/agt/agent/instance-name`

(3) FORMAT section

The FORMAT section specifies the output format of the CCMS alert information.

Table 6–3: Values permitted in the FORMAT section

Label	Description	Permitted values	Default values
COLUMN	Output format of CCMS alert information	Field ID. For details about the field ID, see <i>Output format and contents</i> in the <code>jr3alget</code> command in <i>Chapter 11. Commands</i> .	Column 1: <ALERTDATE> Column 2: <ALERTTIME> Column 3: <MTSYSID> Column 4: <MTMCNAME> Column 5: <OBJECTNAME> Column 6: <FIELDNAME> Column 7: <VALUE> Column 8: <SEVERITY> Column 9: <MSG>
TIMEZONE	Time zone specification for the time information of the following field IDs <ul style="list-style-type: none"> <ALERTDATE> <ALERTTIME> <STATCHGDAT> <STATCHGTIM> 	<ul style="list-style-type: none"> UTC The command will output time information in UTC (Coordinated Universal Time). LOCAL The command will output time information in the local time of the user who executes the command. 	UTC

(4) TRACE section

The TRACE section specifies information about the message log and data log that store the history of CCMS alert information extraction.

Table 6–4: Values permitted in the TRACE section

Label	Description	Permitted values	Default value
MSGLOG_LEVEL	Message log collection level for saving application trace information: <ul style="list-style-type: none"> 0: Do not collect 1: Collect only errors 2: Standard 3: Details 4: Debug 	0-4	2
MSGLOG_SIZE	File size for collecting the message log: <ul style="list-style-type: none"> 0: 2 GB (the maximum value that can be expressed by a 32-bit signed integer (0x7FFFFFFF)) 1-65535: Wraparound within the specified size (in kilobytes) 	0-65535	512
MSGLOG_DIR	Message log file (<code>jr3alget.log</code>) collection-target directory	(Cannot be changed)	log

Label	Description	Permitted values	Default value
DATALOG_LEVEL	Data log collection level for saving various types of data information for applications: <ul style="list-style-type: none"> • 0: Do not collect • 1: Collect only errors • 2: Standard • 3: Details • 4: Debug 	0-4	2
DATALOG_SIZE	File size for collecting the data log: <ul style="list-style-type: none"> • 0: 2 GB (the maximum value that can be expressed by a 32-bit signed integer (0x7FFFFFFF)) • 1-65535: Wraparound within the specified size (in kilobytes) 	0-65535	512
DATALOG_DIR	Data log file (jr3alget.dat) collection-target directory	(Cannot be changed)	log

(5) CONNECT section

The CONNECT section specifies information needed to establish RFC connection with the SAP system.

Table 6–5: Values permitted in the CONNECT section

Label	Description	Permitted values	Default value
LANG	User language used for connection	Japanese and English are supported. 2-byte ISO ID or 1-byte language key that is used in the SAP system: <ul style="list-style-type: none"> • Japanese: JA or J • English: EN or E 	None
CODEPAGE	Code page used to convert character codes in the Unicode version of the SAP system at the destination	Value combined with the language code in the LANG label [#]	None

#

Set the LANG and CODEPAGE labels in the applicable combination shown below. If any other combination of language and code page is specified, an encoding error might occur in the information acquired from the SAP system.

Table 6–6: Combination of language and code page specifications

Connection-target SAP system	Connection language	Language (LANG)	Code page (CODEPAGE)
Unicode version	Japanese	JA	8000
	English	EN	No need to specify. If you specify a code page, specify 1100.
Non-Unicode version	Japanese	JA	No need to specify. If you specify a code page, specify 8000.
	English	EN	No need to specify. If you specify a code page, specify 1100.

If you omit specification of the LANG label, the user language defined in the connection-target system is assumed. If you omit specification of the CODEPAGE label, the default code page in the connection-target system is assumed.

(6) Option section

The `Option` section specifies information that determines the base point for extracting CCMS alert information. If you do not set a label in this section, the default value is used.

For details about the recommended collection base time for remote monitoring, see *8.1 Notes on the collection base time*.

Table 6–7: Values permitted in the Option section

Label	Description	Permitted value	Default value
<code>SHIFTEXTRACTTIME#</code>	The collection base time (units: seconds) that determines the base point for extracting CCMS alert information. Relative to the time at which to perform the collection, specify a value that indicates the amount of time by which to shift the time period (defined by two time points) for which to extract CCMS alert information.	0-600	5

#

If, due to the processing delay in the SAP system, the saved CCMS alert information does not correctly reflect the actual time at which it has arisen, set a value greater than the default value for this label.

The following example shows how to set the collection base time:

- When 10 seconds is to be set as the collection base time

```
[Option]
SHIFTEXTRACTTIME=10
```

6.4 Using a command to extract CCMS alert information

You can also extract the CCMS alert information of an SAP system by executing the `jr3alget` command manually or by having another program execute it automatically. This section describes use of the `jr3alget` command to extract CCMS alert information.

6.4.1 Before executing the command

You should check the following items before you execute the `jr3alget` command to extract the CCMS alert information of an SAP system:

- Settings in the environment parameters file

This is not the same environment parameters file that is used to extract CCMS alert information using CCMS Alert Monitor Command (PD_ALMX) records. For details about this environment parameters file, which is used in conjunction with extracting CCMS alert information by command execution, see [6.4.3 Environment parameters file for extracting CCMS alert information by command execution](#).

- Command execution environment

Check that:

- There are no errors in the network settings
- The SAP system is running
- The SAP system is ready to accept RFC requests

6.4.2 Using the command to extract CCMS alert information

When executing the `jr3alget` command (either manually or automatically from another program), you can select the CCMS alert information to be extracted from the SAP system as follows:

- Extract all CCMS alert information that has been output so far on the day the command is executed.
- Extract only the CCMS alert information that has been output since the last time the command was executed.

For details about the `jr3alget` command, see [jr3alget](#).

Notes

- The CCMS alert information is treated as a single resource in the SAP system and can be referenced from any application servers; therefore, the target can be any application server. Execute only one command per SAP system.
- If you specify values for the same parameter in both the environment parameters file and the `jr3alget` command, the value in the command takes effect.

The two extraction methods are explained below.

(1) Extracting all CCMS alert information that has been output so far on the day the command is executed

The following command specification extracts all CCMS alert information that has been output so far on the day the command is executed (this example assumes that values have been defined for the `CONNECT` and `TARGET` sections in the environment parameters file):

```
jr3alget
```

(2) Extracting only the CCMS alert information that has been output since the last time the command was executed

To extract only the CCMS alert information that has been output since the last time the command was executed, execute the command with the timestamp file specified in the `-lasttime` option. The timestamp file contains a history of the execution dates and times for `jr3alget` command. When you execute the command repeatedly specifying the same timestamp file, you extract consecutive CCMS alert information without any duplication.

Note

If the timestamp file specified in the `-lasttime` option does not exist when the command is executed for the first time, the command creates a new timestamp file, in which case no CCMS alert information is reported.

The following command specification extracts only the CCMS alert information that has been output since the last time the command was executed (this example assumes that values have been defined for the `CONNECT` and `TARGET` sections in the environment parameters file):

```
jr3alget -lasttime altimestamp.txt
```

6.4.3 Environment parameters file for extracting CCMS alert information by command execution

If you specify an environment parameters file as an argument in the `jr3alget` command, the command extracts the CCMS alert information of the SAP system based on the settings in the file.

You create this environment parameter file as a text file.

(1) Setup procedure

To set up the environment parameters file:

1. Before you edit the environment parameters file, check that the `jr3alget` command is not running.
2. To create a new environment parameters file, copy the sample environment parameters file under the name `jr3alget.ini`.
3. Copy the sample environment parameters file under the name `jr3alget.ini`.

This `jr3alget.ini` becomes the default environment parameters file. The sample environment parameters file is as follows:

In Windows:

```
installation-folder\agtm\evtrap\jr3alget.ini.sample
```

In Linux:

```
/opt/jp1pc/agtm/evtrap/jr3alget.ini.sample
```

4. Open the jr3alget.ini file.

5. Edit the settings.

The settings in the default environment parameters file are as follows; for details about the settings, see (2) below.

```
[CONNECT]
ASHOST=localhost
SYSNR=00
CLIENT=000
USER=CPIC
PASSWD=ADMIN
;LANG=EN
;CODEPAGE=1100

[COMMAND]
;WORKDIR=

[TRACE]
MSGLOG_LEVEL=2
MSGLOG_SIZE=512
MSGLOG_DIR=.
DATALOG_LEVEL=2
DATALOG_SIZE=512
DATALOG_DIR=.

[TARGET]
;MONITOR_SET=SAP CCMS Technical Expert Monitors
;MONITOR=All Monitoring Contexts

[FORMAT]
;COLUMN=<ALERTDATE>
;COLUMN=<ALERTTIME>
;COLUMN=<MTSYSID>
;COLUMN=<MTMCNAME>
;COLUMN=<OBJECTNAME>
;COLUMN=<FIELDNAME>
;COLUMN=<VALUE>
;COLUMN=<SEVERITY>
;COLUMN=<MSG>

[EXTRACTFILE]
TYPE=WRAP2
NUM=5
SIZE=10240
X2PATH=ALERT
```

In the case of an item that begins with a semicolon (;), the setting is disabled by default, because the semicolon indicates that it is a comment line. To enable the setting, remove the semicolon.

6. Save the environment parameters file.

By specifying the `-cnf` option in the `jr3alget` command, you can extract the CCMS alert information of the SAP system based on the settings in the environment parameters file.

(2) Settings

Specify the settings in the environment parameters file in the following format:

```

[section]
label=value
label=value
...
...
[section]
label=value
label=value

```

Notes

- Do not specify any unneeded characters, such as spaces at the beginning of a line or before and after an equals sign (=).
- The values specified in *section* and *label* are not case-sensitive.
- A line beginning with a semicolon (;) is treated as a comment.

The following tables describe the contents of each section in the environment parameters file. In a table, the *Argument* column indicates the argument that is specified in the `jr3alget` command, if applicable. N/A means that the item cannot be specified with the command.

(a) CONNECT section

The CONNECT section specifies information needed to establish RFC connection with the SAP system at the time of command execution.

Table 6–8: Values permitted in the CONNECT section

Label	Description	Permitted values	Default value	Argument
ASHOST	Host name of the connection-target application server (which can be verified by transaction code SM51)	1 to 100 single-byte alphanumeric characters in one of the following formats: <ul style="list-style-type: none"> • Host name specified in the <code>hosts</code> file • IP address • SAP router address 	localhost	-h
SYSNR	System number that can be identified by the connection-target application server host	0-99	00	-s
CLIENT	User's client name used for establishing connection	0-999	000	-c
USER	User name used for establishing connection ^{#1}	1 to 12 single-byte alphanumeric characters	CPIC	-u
PASSWD	User's password used for establishing connection ^{#2}	1 to 8 single-byte characters ^{#3}	ADMIN	-p
PASSWD2	User's extended password used for establishing connection ^{#2}	1 to 40 single-byte characters ^{#3}	ADMIN	-p2
LANG	User language used for connection	Japanese and English are supported. 2-byte ISO ID or 1-byte language key that is used in the SAP system: <ul style="list-style-type: none"> • Japanese: JA or J • English: EN or E 	None	-l

Label	Description	Permitted values	Default value	Argument
CODEPAGE	Code page used to convert character codes in the Unicode version of the SAP system at the destination	Value combined with the language in the LANG label#4	None	-codepage

#1

The user specified in this label must have already been granted the following authorizations:

Table 6–9: Authorizations required by the user to establish RFC connection with function modules (S_RFC)

Authorization	Description	Value
RFC_TYPE	Type of RFC object to be protected	FUGR (function group)
RFC_NAME	RFC name to be protected	*
ACTVT	Activity	16 (execution)

Table 6–10: Authorizations required for use of external management interfaces (S_XMI_PROD)

Authorization	Description	Value
EXTCOMPANY	Company name of the external management tool	HITACHI
EXTPRODUCT	Program name of the external management tool	JP1
INTERFACE	Interface ID	XAL

You can use the following user types for the user specified in this label:

- Dialog
- System
- Communication
- Service

#2

Specify the `PASSWD` label if the SAP system is applying conventional password rules. Specify the `PASSWD2` label if the SAP system is applying extended password rules. The `PASSWD` and `PASSWD2` labels are mutually exclusive.

#3

A user's password or extended password that is used for establishing connection must consist of single-byte numeric characters (from 0 to 9), single-byte alphabetic characters (from a to z, A to Z), and the following single-byte symbols:

!, @, \$, %, &, /, (,), =, ?, ', `*, +, ~, #, -, _, ., :, {, [,], }, <, >, |

#4

Set the `LANG` and `CODEPAGE` labels in the applicable combination shown below. If any other combination of language and code page is specified, an encoding error might occur in the information acquired from the SAP system.

Table 6–11: Combination of language and code page specifications

Connection-target SAP system	Connection language	Language (LANG)	Code page (CODEPAGE)
Unicode version	Japanese	JA	8000
	English	EN	No need to specify. If you specify a code page, specify 1100.
Non-Unicode version	Japanese	JA	No need to specify. If you specify a code page, specify 8000.

Connection-target SAP system	Connection language	Language (LANG)	Code page (CODEPAGE)
Non-Unicode version	English	EN	No need to specify. If you specify a code page, specify 1100.

If you omit specification of the LANG label, the user language defined in the connection-target system is assumed.

If you omit specification of the CODEPAGE label, the default code page in the connection-target system is assumed.

(b) COMMAND section

The COMMAND section specifies information about the work directory for the `jr3alget` command.

Table 6–12: Values permitted in the COMMAND section

Label	Description	Permitted values	Default value	Argument
WORKDIR	Work directory for the command	1 to 255 single-byte alphanumeric characters. If a relative path is specified, it is treated as the path relative to the current directory.	Current directory	N/A

(c) TRACE section

The TRACE section specifies information about the message log and data log that store the history of CCMS alert information extraction.

Table 6–13: Values permitted in the TRACE section

Label	Description	Permitted values	Default value	Argument
MSGLOG_LEVEL	Message log collection level for saving application trace information: <ul style="list-style-type: none"> 0: Do not collect 1: Collect only errors 2: Standard 3: Details 4: Debug 	0-4	2	N/A
MSGLOG_SIZE	File size for collecting the message log: <ul style="list-style-type: none"> 0: 2 GB (the maximum value that can be expressed by a 32-bit signed integer (0x7FFFFFFF)) 1-65535: Wraparound within the specified size (in kilobytes) 	0-65535	512	N/A
MSGLOG_DIR	Message log file (<code>jr3alget.log</code>) collection-target directory	1 to 255 single-byte alphanumeric characters. The total length, including file name <code>jr3alget.log</code> , must not exceed 255 bytes. If a relative path is specified, it is treated as the path relative to the work directory for the command.	Work directory for the command (or the current directory if it has not been changed by the WORKDIR label in the COMMAND section)	N/A
DATALOG_LEVEL	Data log collection level for saving various types of data information for applications: <ul style="list-style-type: none"> 0: Do not collect 	0-4	2	N/A

Label	Description	Permitted values	Default value	Argument
DATALOG_LEVEL	<ul style="list-style-type: none"> 1: Collect only errors 2: Standard 3: Details 4: Debug 	0-4	2	N/A
DATALOG_SIZE	File size for collecting data log: <ul style="list-style-type: none"> 0: 2 GB (the maximum value that can be expressed by a 32-bit signed integer (0x7FFFFFFF)) 1-65535: Wraparound within the specified size (in kilobytes) 	0-65535	512	N/A
DATALOG_DIR	Data log file (jr3alget.dat) collection-target directory	1 to 255 single-byte alphanumeric characters. The total length, including file name jr3alget.log, must not exceed 255 bytes. If a relative path is specified, it is treated as the path relative to the work directory for the command.	Work directory for the command (or the current directory if it has not been changed by the WORKDIR label in the COMMAND section)	N/A

(d) TARGET section

The TARGET section specifies information that identifies the CCMS alert information to be extracted.

Table 6–14: Values permitted in the TARGET section

Label	Description	Permitted values	Default values	Argument
MONITOR_SET	Monitor set name (for details, see the -ms option)	1 to 60 single-byte alphanumeric characters	SAP CCMS Technical Expert Monitors	-ms
MONITOR	Monitor name (for details, see the -mn option)	1 to 60 single-byte alphanumeric characters	All Monitoring Contexts	-mn

(e) FORMAT section

The FORMAT section specifies the output format of the CCMS alert information.

Table 6–15: Values permitted in the FORMAT section

Label	Description	Permitted values	Default values	Argument
COLUMN	Output format of CCMS alert information	Field ID. For details about the field ID, see <i>Output format and contents</i> in the jr3alget command in <i>Chapter 11. Commands</i> .	Column 1: <ALERTDATE> Column 2: <ALERTTIME> Column 3: <MTSYSID> Column 4: <MTMCNAME> Column 5: <OBJECTNAME> Column 6: <FIELDNAME> Column 7: <VALUE> Column 8: <SEVERITY> Column 9: <MSG>	N/A
TIMEZONE	Time zone for time information specified in field IDs <ALERTDATE>,	<ul style="list-style-type: none"> UTC Output in UTC (international time standard).	UTC	TIMEZONE

Label	Description	Permitted values	Default values	Argument
TIMEZONE	<ALERTTIME>, <STATCHGDAT>, and <STATCHGTIM>	<ul style="list-style-type: none"> LOCAL Output in the local time at the location of the user who executed the command.	UTC	TIMEZONE

(f) EXTRACTFILE section

The EXTRACTFILE section specifies information about the output file for the CCMS alert information.

Table 6–16: Values permitted in the EXTRACTFILE section

Label	Description	Permitted values	Default value
TYPE	Format of file for storing CCMS Alert Information: <ul style="list-style-type: none"> WRAP1 This file is in wraparound format, which means that data is overwritten when the amount of CCMS Alert Information reaches a specified value. WRAP2 This format consists of the number of files specified in the NUM label. When the amount of data in the first file reaches a specified value, new data is written in the second file, starting at the top, after all existing data is deleted from the second file. When all of the files are full, new data is again written in the first file, starting at the top, after all existing data is deleted from the first file. If you configure a new environment for PFM - Agent for Enterprise Applications, we recommend that you specify WRAP2. If you want to change the format of storage files after you have started system operations, first stop any products monitoring the storage files, and then delete the storage files and their management files ^{#1} .	WRAP1 or WRAP2	WRAP1
SIZE	Size of one storage file: <ul style="list-style-type: none"> 0: 2 GB (the maximum value that can be expressed by a 32-bit signed integer (0x7FFFFFFF)) 1 to 65535: Wraparound within the specified size (kilobytes) 	0 to 65535	10240 ^{#3}
X2PATH	<ul style="list-style-type: none"> WRAP1 specified in the TYPE label Specify the path of storage file that is to be used when storage file output is specified in the -x2 option.^{#1, #3} WRAP2 specified in the TYPE label 	<ul style="list-style-type: none"> WRAP1 specified in the TYPE label 1 through 251 bytes of single-byte alphanumeric characters^{#5} WRAP2 specified in the TYPE label 1 through 254 bytes of single-byte alphanumeric characters^{#5} 	--

Label	Description	Permitted values	Default value
X2PATH	Specify the storage file that is to be used when storage file output is specified in the <code>-x2</code> option. ^{#3, #4}	<ul style="list-style-type: none"> • WRAP1 specified in the TYPE label 1 through 251 bytes of single-byte alphanumeric characters^{#5} • WRAP2 specified in the TYPE label 1 through 254 bytes of single-byte alphanumeric characters^{#5} 	--
NUM	Number of files to be stored in the WRAP2 format. This is applicable only when WRAP2 is specified in the TYPE label.	2 to 9	5

Legend:

--: Not applicable

#1

If the WRAP1 format is used, a management file having the name *storage-file-name*.ofs is created in the same directory as for the storage file.

Example:

If ALERT is specified as the storage file name, a management file named ALERT.ofs is created in addition to the ALERT file.

If you delete the storage file, you must also delete the management file.

#2

For details about the default value that is used when the product is upgraded from version 09-00 or earlier, see [Appendix H. Migration Steps and Notes on Migration](#).

#3

If you do not use the default storage location, the storage and management files will not be collected when using the `jpccras` command. Therefore, in the event of a problem, you need to manually collect the storage and management files.

#4

A value in the range specified in the NUM label (default: 1 through 5) is assigned to this value to obtain the file name.

#5

If a relative path is specified, the command's working directory (directory specified in the WORKDIR label in the COMMAND section) is assumed as the current directory. If no working directory is specified, the directory listed below is assumed as the current directory. The environment directory means a directory on the shared disk that was specified when the logical host was created.

In Windows:

Physical host environment: *installation-folder*\agtm\agent\instance-name

Logical host environment: *environment-directory*\jplpc\agtm\agent\instance-name

In Linux:

Physical host environment: /opt/jplpc/agtm/agent/instance-name

Logical host environment: *environment-directory*/jplpc/agtm/agent/instance-name

(g) Option section

The Option section specifies information that determines the base point for extracting CCMS alert information.

7

Collecting Monitor Information

This chapter describes how to use PFM - Agent for Enterprise Applications to collect an SAP system's monitor information.

7.1 Overview of collecting monitor information

PFM - Agent for Enterprise Applications enables you to collect an SAP system's monitor information on the basis of user definitions.

SAP system monitor information means the information about an SAP system's performance that is managed by the CCMS monitoring architecture. A collection of individual performance information items is called a *monitor set*, and it is managed hierarchically in a tree structure called a *monitor*.

Of the various types of performance information defined in a monitor set and monitor, the items with the performance attribute, together with their values, can be collected as performance data, mapped to a record type and fields provided by PFM - Agent for Enterprise Applications, and then stored as user-defined records in PFM - Agent for Enterprise Applications.

PFM - Agent for Enterprise Applications manages such user-defined records as User defined Monitor (Perf.) (PI_UMP) records. When there are multiple performance data items, for each data item, a field is added in the user record one row at a time. As a result, each user record becomes a multi-row record. A multi-row record is a multi-instance record.

For details about records, see [Chapter 10. Records](#).

Note

- When the `jr3alget` command is executed directly to extract CCMS alert information while the TZ environment variable is defined in the command execution environment, problems might occur such as CCMS alert information not being extracted, or the time information field for extracted CCMS alert information being output as 1 hour late. As such, do not define a time zone for the TZ environment variable of the command execution environment. The applied time zone will be the one defined in the **Windows Date and Time** Properties dialog box.
- When collecting PI_UMP records, performance data that have the same MTE name (MTE Name field) are collected into one case when recording in the Store database.
- As a result, the items displayed in the history report may be fewer than the items displayed in the real-time report.

7.2 Settings for collecting monitor information

You must set the following items in order to collect SAP system monitor information:

- Monitor set name and monitor name
- Performance data collection settings

The following figure shows the flow of tasks for collecting SAP system monitor information.

Figure 7–1: Flow of tasks for collecting SAP system monitor information

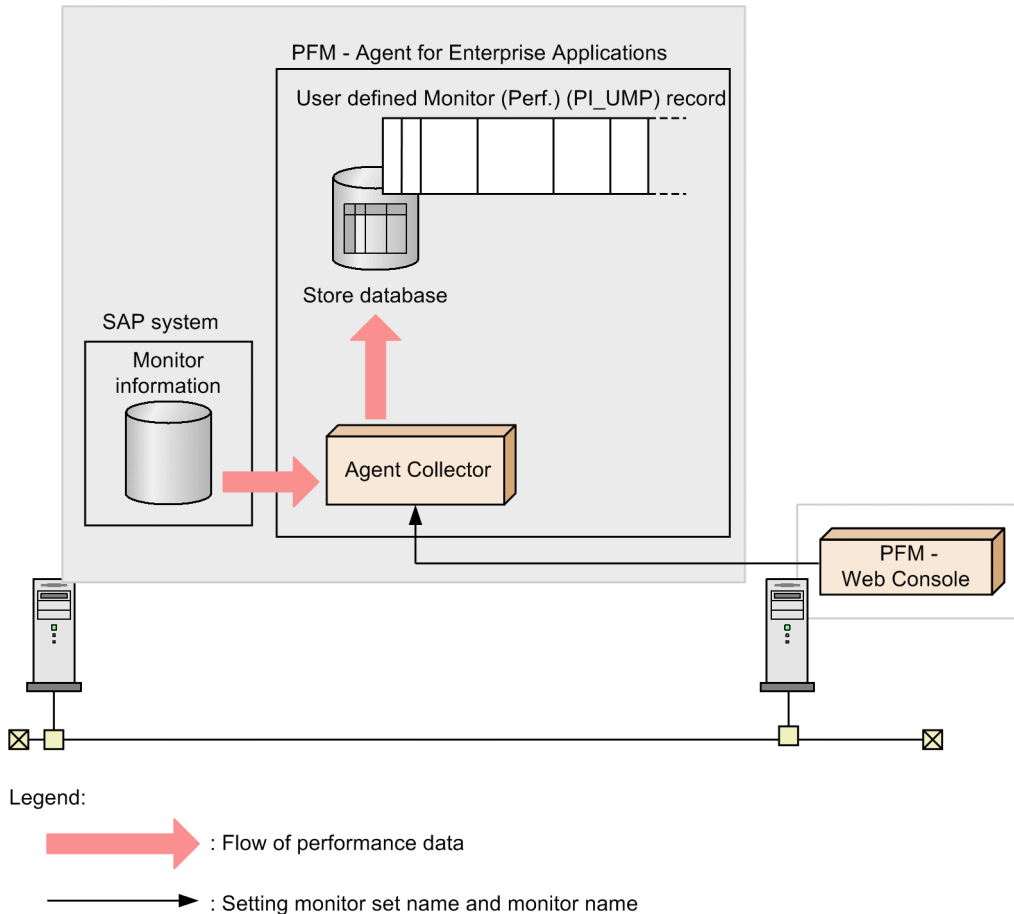

7.2.1 Setting a monitor set name and a monitor name

This subsection describes how to set a monitor set name and a monitor name from PFM - Web Console.

A Performance Management user with the administrator user permission must execute this procedure.

To set a monitor set name and monitor name:

1. Log on to PFM - Web Console.

For details about logging on to PFM - Web Console, see the chapter that describes startup and termination of Performance Management in the *JPI/Performance Management User's Guide*.

2. In the Main window, from the navigation frame, choose the **Services** tab.

3. In the Services window, from the navigation frame, select the agent that you wish to use to collect SAP system monitor information.
A check mark appears next to the selected agent.
4. In the method frame, choose the **Properties** method.
The Properties window appears.
5. In **Agent**, click the `PI_UMP` folder.
Settings for the monitor set name and monitor name are displayed.
6. Under **MONITOR_SET** and **MONITOR**, set **Value**.
Set a monitor set name and a monitor name for the SAP system monitor information that you wish to collect. Each value must consist of 1 to 60 single-byte alphanumeric characters.
You can check the monitor set name and monitor name with transaction code `RZ20`. Note that these settings are case sensitive.
7. Click the **OK** button.
The settings take effect.

7.2.2 Settings for performance data collection

This subsection describes how to store in the Store database performance data obtained from SAP system monitor information.

A Performance Management user with the administrator user permission must execute this procedure.

To store performance data in the Store database:

1. Use PFM - Web Console to specify settings so that performance data in User defined Monitor (Perf.) (`PI_UMP`) records is stored in the Store database.
For details about the setting method, see the chapter that describes management of operation monitoring data in the *JPI/Performance Management User's Guide*.

Note

A maximum of 4,096 records can be acquired during each performance data collection. If the number of records exceeds this value, the excess records are discarded.

8

Notes on Operating

This chapter presents the precautions to be observed when operating PFM - Agent for Enterprise Applications.

8.1 Notes on the collection base time

Observe the following precautions when setting the collection base time:

- Add the `Option` section and the `SHIFTEXTRACTTIME` label when you create or update the environment parameters file.
- Make adjustments to the collection base time recommended for remote monitoring by taking into account the following concept behind the recommended collection base time:

Concept behind the collection base time

Due to processing delay in the SAP system, the saved system log or CCMS alert information may not accurately reflect the actual time at which it arose. In this case, even when the local host is being monitored, some of the system log or CCMS alert information is not extracted, which is the same as what happens when a time delay in the SAP system (time difference between hosts) exceeds the collection base time. To avoid this problem, the default collection base time is set at 5 seconds. When a remote host is to be monitored, the effect of time delay in the SAP system must also be taken into consideration, and therefore 5 more seconds (which gives sufficient margin to accommodate an environment that meets the prerequisite of keeping a time difference between hosts to less than 1 second) is added to the collection base time, with 10 seconds being set as the recommended collection base time.

8.2 Notes on the SAP system time zone

Observe the following precautions when setting a time zone for the SAP system:

- The sample file for the environment parameters file does not contain the `Option` section or the `SAPTIMEZONEOFFSET` label. You have to add them when you create an environment parameters file.
- The system log or CCMS alert information that has arisen in the SAP system can be viewed from the JP1 side only after it is collected after elapse of the time set with `SHIFTEXTRACTTIME`. When changing the recommended `SHIFTEXTRACTTIME` setting, you have to take into account a delay in the collection timing. The following figure shows how the `SHIFTEXTRACTTIME` setting affects the extraction of system log or CCMS alert information.

Figure 8–1: How the `SHIFTEXTRACTTIME` setting affects the range of information to be extracted

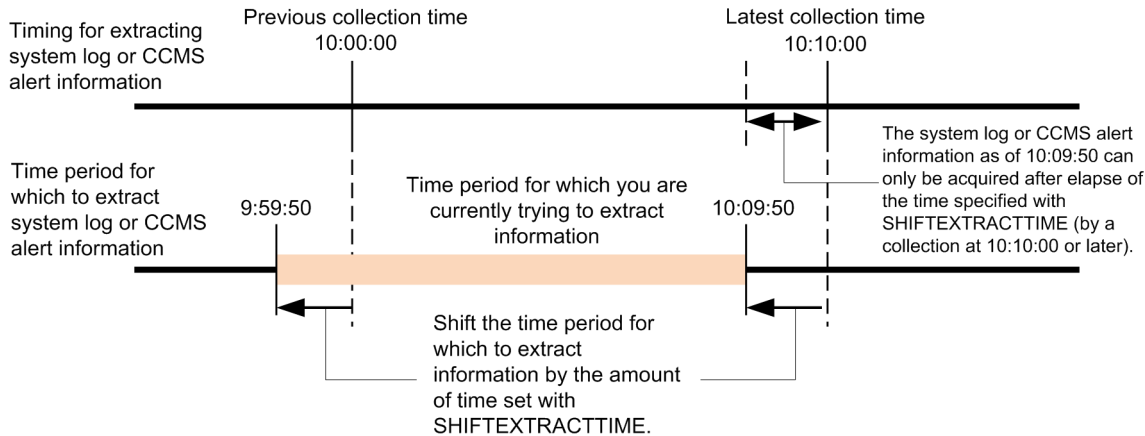

8.3 Notes on system operation

- For notes on executing the `jpctool service list` command for the Agent Collector service or Agent Store service, see the chapter that describes commands in the manual *JP1/Performance Management Reference*.
- For notes on executing the `jpccspm start` command or the `jpccspm stop` command for PFM - Agent for Enterprise Applications, see the chapter that describes commands in the manual *JP1/Performance Management Reference*.
- When starting the service, each service of PFM - Agent can be started when each service of PFM - Manager is not running, but PFM - Agent will run in the stand-alone mode, and functions that can be used with Performance Management are limited.

When stopping the service, each service of PFM - Agent can be stopped when each service of PFM - Manager is running, but when PFM - Manager is not running, the functions that can be used with Performance Management are limited. Also, after restarting PFM - Manager, the latest status for PFM - Agent might be displayed incorrectly. In this case, check the latest status by performing the following appropriate procedure:

- When PFM - Agent is not running:
Start up PFM - Agent, and then check the status.
- When PFM - Agent is running:
Restart PFM - Manager, wait a while, and then check the status again.

When starting the service, it is recommended that each service of PFM - Agent be started after each service of PFM - Manager is started. When stopping the service, it is recommended that each service of PFM - Manager be stopped after each service of PFM - Agent is stopped. For details about the stand-alone mode, see *When starting PFM - Agent or PFM - RM in a large-scale system* in the manual *JP1/Performance Management User's Guide*.

- PFM - Agent for Enterprise Applications cannot use the 3rd level and 4th level Kanji characters defined in the JIS x 0213.
- Under Windows Server 2012 and Windows Server 2016, a User Account Control (UAC) dialog box might be displayed during uninstallation. Respond to this UAC dialog box to continue uninstallation.
- In Linux, when you see the field explanation for PFM - Agent for Enterprise Applications in PFM - Web Console, a message indicating "No explanation provided" might appear. If this happens, use the setup file supplied with PFM - Agent for Enterprise Applications 10-00 or later to register agents. For details about this procedure, see [3.1.5 Setup procedure in Windows](#) and [3.2.5 Setup procedure in Linux](#).

9

Monitoring Template

This chapter describes the monitoring template for PFM - Agent for Enterprise Applications.

Overview of the monitoring template

The Performance Management products provide the following methods for defining alarms and reports:

- Using the alarms and reports defined by PFM - Agent
- Copying and customizing the alarms and reports defined by PFM - Agent
- Using a wizard to define new information

A set of alarms and reports provided by PFM - Agent is called a *monitoring template*. Because the necessary information is predefined for the reports and alarms in the monitoring template, you can copy them in order to use the solution set as is or you can customize them as appropriate for your environment. This eliminates the need to use the wizard to create new definitions, thus simplifying the preparations for monitoring the operating status of desired programs.

This chapter describes the alarm and report settings in the monitoring template that have been defined by PFM - Agent for Enterprise Applications.

For details about how to use the monitoring template, see the chapter that describes operation monitoring by alarms and report creation for operation analysis in the *JP1/Performance Management User's Guide*.

Important

The threshold values set for a monitoring template's alarms are examples for reference. To use the monitoring template's alarms, copy them, and then set threshold values that are appropriate for the environment and OS.

Format of alarm explanations

This section describes the format used to explain alarms. Alarms are presented in alphabetical order.

Alarm name

Indicates the name of an alarm in the monitoring template.

Overview

Provides an overview of the programs that can be monitored by the alarm.

Main settings

Explains the main settings for this alarm in tabular format. This table lists the correspondence between alarm settings and the Properties window, which is displayed in PFM - Web Console when the alarm icon is clicked on the **Alarms** page and then the **Properties** method is clicked. For details about the settings for each alarm, check the Properties window for the alarm in PFM - Web Console.

In the *Setting* column, a cell with three dashes (--) means that the setting is always ignored.

If the abnormal condition is the same as the warning condition in a conditional expression, the system issues only the abnormal alarm event.

Alarm table

Indicates the alarm table that contains this alarm.

Related reports

Indicates the reports in the monitoring template that are associated with this alarm. You can display these reports by clicking the  icon in the Display Alarm Status method, which is displayed in PFM - Web Console when the agent icon on the **Agents** page is clicked.

When you check the reports tree in the PFM - Web Console window, replace the path beginning with `Reports/` with `System Reports/`.

List of alarms

A table containing alarms is called an *alarm table*. The alarms defined in the monitoring template for PFM - Agent for Enterprise Applications are in alarm table format and are stored in the `SAP System` folder that is displayed on the **Alarms** page of PFM - Web Console.

The alarm tables are identified as follows:

- PFM SAP System Template Alarms 10.00
- PFM SAP System Template Alarms [Background Processing] 10.00
- PFM SAP System Template Alarms [Background Service] 10.00
- PFM SAP System Template Alarms [Dialog Utilization] 10.00

Information in square brackets in an alarm table name

Square brackets enclose the name of that alarm table's monitoring item. An alarm table without square brackets consists of basic alarms

10.00 at the end of an alarm table name

Indicates the version of the alarm table.

For PFM - Agent for Enterprise Applications, alarm tables for a version that is not supported by the Performance Management system being used might be displayed among the alarms. When you use alarms defined in a monitoring template, check the version of the alarm table used in the Performance Management system for version compatibility.

For details about the alarm table version and version compatibility, see [Appendix I. Version Compatibility](#).

The following table lists and describes the alarms defined in the monitoring template of PFM - Agent for Enterprise Applications.

Table 9–1: List of alarms

Alarm table name	Alarm name	Monitoring target
PFM SAP System Template Alarms 10.00	<code>Buffer - CUA</code>	SAP buffer (CUA buffer) hit rate
	<code>Buffer - FieldDescri</code>	SAP buffer (field description buffer) hit rate
	<code>Buffer - GenericKey</code>	SAP buffer (generic key buffer) hit rate
	<code>Buffer - InitialReco</code>	SAP buffer (initial records buffer) hit rate
	<code>Buffer - Program</code>	SAP buffer (program buffer) hit rate
	<code>Buffer - Screen</code>	SAP buffer (screen buffer) hit rate
	<code>Buffer - ShortNameTA</code>	SAP buffer (short nametab buffer) hit rate
	<code>Buffer - SingleRecor</code>	SAP buffer (single record buffer) hit rate
	<code>Buffer - TableDefini</code>	SAP buffer (table definition buffer) hit rate
	<code>Dialog ResponseTime</code>	Dialog task's response time
	<code>Extended Memory</code>	Usage of extended memory
	<code>Heap Memory</code>	Usage of heap memory
	<code>Paging Area</code>	Usage of the paging area
	<code>Roll Area</code>	Usage of the roll area

Alarm table name	Alarm name	Monitoring target
PFM SAP System Template Alarms [Background Processing] 10.00	<code>SystemWideQueue</code>	Number of jobs waiting to be executed (average in the entire system)
PFM SAP System Template Alarms [Background Service] 10.00	<code>ServerSpecificQueue</code>	Number of released jobs waiting to be executed
	<code>Utilization %</code>	Average usage of the server's background work processes
PFM SAP System Template Alarms [Dialog Utilization] 10.00	<code>QueueLength %</code>	Average usage of the dispatcher queue for dialog work processes
	<code>Utilization %</code>	Average usage of the application server's dialog processes

Buffer - CUA

Overview

The Buffer - CUA alarm monitors the SAP buffer (CUA buffer) hit rate.

Main settings

Alarm properties in PFM - Web Console		Setting
Item	Details	
Main Information	Product	SAP Sytem (3.0)
	Alarm message text	--
	Monitor whether the value exists	Not selected
	Enable alarm	Selected
	Alarm notification	Notify when the state changed
	Notification target	State changes for the alarm
	Evaluate all data	Not selected
	Monitoring time range	Always monitor
	Report alarm when the following damping condition is reached	Not selected
	occurrence(s) during	--
	interval(s)	--
Alarm Conditions	Record	Workload Summary Interval (PI)
	Field	CUA HitRatio %
	Abnormal condition	CUA HitRatio % < 60
	Warning condition	CUA HitRatio % < 80
Actions	Email	--
	Command	--
	SNMP	Abnormal, Warning, Normal

Related reports

Reports/SAP System/SAP Basis/Web Application Server/Troubleshooting/Recent Past/SAP Buffer Hitratio

Buffer - FieldDescri

Overview

The Buffer - FieldDescri alarm monitors the SAP buffer (field description buffer) hit rate.

Main settings

Alarm properties in PFM - Web Console		Setting
Item	Details	
Main Information	Product	SAP Sytem (3.0)
	Alarm message text	--
	Monitor whether the value exists	Not selected
	Enable alarm	Selected
	Alarm notification	Notify when the state changed
	Notification target	State changes for the alarm
	Evaluate all data	Not selected
	Monitoring time range	Always monitor
	Report alarm when the following damping condition is reached	Not selected
	occurrence(s) during	--
	interval(s)	--
Alarm Conditions	Record	Workload Summary Interval (PI)
	Field	FieldDescription HitRatio %
	Abnormal condition	FieldDescription HitRatio % < 60
	Warning condition	FieldDescription HitRatio % < 80
Actions	Email	--
	Command	--
	SNMP	Abnormal, Warning, Normal

Related reports

Reports/SAP System/SAP Basis/Web Application Server/Troubleshooting/Recent Past/SAP Buffer Hitratio

Buffer - GenericKey

Overview

The Buffer - GenericKey alarm monitors the SAP buffer (generic key buffer) hit rate.

Main settings

Alarm properties in PFM - Web Console		Setting
Item	Details	
Main Information	Product	SAP Sytem (3.0)
	Alarm message text	--
	Monitor whether the value exists	Not selected
	Enable alarm	Selected
	Alarm notification	Notify when the state changed
	Notification target	State changes for the alarm
	Evaluate all data	Not selected
	Monitoring time range	Always monitor
	Report alarm when the following damping condition is reached	Not selected
	occurrence(s) during	--
	interval(s)	--
Alarm Conditions	Record	Workload Summary Interval (PI)
	Field	GenericKey HitRatio %
	Abnormal condition	GenericKey HitRatio % < 60
	Warning condition	GenericKey HitRatio % < 80
Actions	Email	--
	Command	--
	SNMP	Abnormal, Warning, Normal

Related reports

Reports/SAP System/SAP Basis/Web Application Server/Troubleshooting/Recent Past/SAP Buffer Hitratio

Buffer - InitialReco

Overview

The Buffer - InitialReco alarm monitors the SAP buffer (initial records buffer) hit rate.

Main settings

Alarm properties in PFM - Web Console		Setting
Item	Details	
Main Information	Product	SAP Sytem (3.0)
	Alarm message text	--
	Monitor whether the value exists	Not selected
	Enable alarm	Selected
	Alarm notification	Notify when the state changed
	Notification target	State changes for the alarm
	Evaluate all data	Not selected
	Monitoring time range	Always monitor
	Report alarm when the following damping condition is reached	Not selected
	occurrence(s) during	--
	interval(s)	--
Alarm Conditions	Record	Workload Summary Interval (PI)
	Field	InitialRecords HitRatio %
	Abnormal condition	InitialRecords HitRatio % < 60
	Warning condition	InitialRecords HitRatio % < 80
Actions	Email	--
	Command	--
	SNMP	Abnormal, Warning, Normal

Related reports

Reports/SAP System/SAP Basis/Web Application Server/Troubleshooting/Recent Past/SAP Buffer Hitratio

Buffer - Program

Overview

The Buffer - Program alarm monitors the SAP buffer (program buffer) hit rate.

Main settings

Alarm properties in PFM - Web Console		Setting
Item	Details	
Main Information	Product	SAP Sytem (3.0)
	Alarm message text	--
	Monitor whether the value exists	Not selected
	Enable alarm	Selected
	Alarm notification	Notify when the state changed
	Notification target	State changes for the alarm
	Evaluate all data	Not selected
	Monitoring time range	Always monitor
	Report alarm when the following damping condition is reached	Not selected
	occurrence(s) during	--
	interval(s)	--
Alarm Conditions	Record	Workload Summary Interval (PI)
	Field	Program HitRatio %
	Abnormal condition	Program HitRatio % < 60
	Warning condition	Program HitRatio % < 80
Actions	Email	--
	Command	--
	SNMP	Abnormal, Warning, Normal

Related reports

Reports/SAP System/SAP Basis/Web Application Server/Troubleshooting/Recent Past/SAP Buffer Hitratio

Buffer - Screen

Overview

The Buffer - Screen alarm monitors the SAP buffer (screen buffer) hit rate.

Main settings

Alarm properties in PFM - Web Console		Setting
Item	Details	
Main Information	Product	SAP Sytem (3.0)
	Alarm message text	--
	Monitor whether the value exists	Not selected
	Enable alarm	Selected
	Alarm notification	Notify when the state changed
	Notification target	State changes for the alarm
	Evaluate all data	Not selected
	Monitoring time range	Always monitor
	Report alarm when the following damping condition is reached	Not selected
	occurrence(s) during	--
	interval(s)	--
Alarm Conditions	Record	Workload Summary Interval (PI)
	Field	Screen HitRatio %
	Abnormal condition	Screen HitRatio % < 60
	Warning condition	Screen HitRatio % < 80
Actions	Email	--
	Command	--
	SNMP	Abnormal, Warning, Normal

Related reports

Reports/SAP System/SAP Basis/Web Application Server/Troubleshooting/Recent Past/SAP Buffer Hitratio

Buffer - ShortNameTA

Overview

The Buffer - ShortNameTA alarm monitors the SAP buffer (short nametab buffer) hit rate.

Main settings

Alarm properties in PFM - Web Console		Setting
Item	Details	
Main Information	Product	SAP Sytem (3.0)
	Alarm message text	--
	Monitor whether the value exists	Not selected
	Enable alarm	Selected
	Alarm notification	Notify when the state changed
	Notification target	State changes for the alarm
	Evaluate all data	Not selected
	Monitoring time range	Always monitor
	Report alarm when the following damping condition is reached	Not selected
	occurrence(s) during	--
	interval(s)	--
Alarm Conditions	Record	Workload Summary Interval (PI)
	Field	ShortNameTAB HitRatio %
	Abnormal condition	ShortNameTAB HitRatio % < 60
	Warning condition	ShortNameTAB HitRatio % < 80
Actions	Email	--
	Command	--
	SNMP	Abnormal, Warning, Normal

Related reports

Reports/SAP System/SAP Basis/Web Application Server/Troubleshooting/Recent Past/SAP Buffer Hitratio

Buffer - SingleRecor

Overview

The Buffer - SingleRecor alarm monitors the SAP buffer (single record buffer) hit rate.

Main settings

Alarm properties in PFM - Web Console		Setting
Item	Details	
Main Information	Product	SAP Sytem (3.0)
	Alarm message text	--
	Monitor whether the value exists	Not selected
	Enable alarm	Selected
	Alarm notification	Notify when the state changed
	Notification target	State changes for the alarm
	Evaluate all data	Not selected
	Monitoring time range	Always monitor
	Report alarm when the following damping condition is reached	Not selected
	occurrence(s) during	--
	interval(s)	--
Alarm Conditions	Record	Workload Summary Interval (PI)
	Field	SingleRecord HitRatio %
	Abnormal condition	SingleRecord HitRatio % < 60
	Warning condition	SingleRecord HitRatio % < 80
Actions	Email	--
	Command	--
	SNMP	Abnormal, Warning, Normal

Related reports

Reports/SAP System/SAP Basis/Web Application Server/Troubleshooting/Recent Past/SAP Buffer Hitratio

Buffer - TableDefini

Overview

The Buffer - TableDefini alarm monitors the SAP buffer (table definition buffer) hit rate.

Main settings

Alarm properties in PFM - Web Console		Setting
Item	Details	
Main Information	Product	SAP Sytem (3.0)
	Alarm message text	--
	Monitor whether the value exists	Not selected
	Enable alarm	Selected
	Alarm notification	Notify when the state changed
	Notification target	State changes for the alarm
	Evaluate all data	Not selected
	Monitoring time range	Always monitor
	Report alarm when the following damping condition is reached	Not selected
	occurrence(s) during	--
	interval(s)	--
Alarm Conditions	Record	Workload Summary Interval (PI)
	Field	TableDefinition HitRatio %
	Abnormal condition	TableDefinition HitRatio % < 60
	Warning condition	TableDefinition HitRatio % < 80
Actions	Email	--
	Command	--
	SNMP	Abnormal, Warning, Normal

Related reports

Reports/SAP System/SAP Basis/Web Application Server/Troubleshooting/Recent Past/SAP Buffer Hitratio

Dialog ResponseTime

Overview

The Dialog ResponseTime alarm monitors the dialog task's response time.

Main settings

Alarm properties in PFM - Web Console		Setting
Item	Details	
Main Information	Product	SAP Sytem (3.0)
	Alarm message text	--
	Monitor whether the value exists	Not selected
	Enable alarm	Selected
	Alarm notification	Notify when the state changed
	Notification target	State changes for the alarm
	Evaluate all data	Not selected
	Monitoring time range	Always monitor
	Report alarm when the following damping condition is reached	Not selected
	occurrence(s) during	--
	interval(s)	--
Alarm Conditions	Record	Workload Summary Interval (PI)
	Field	ResponseTime
	Abnormal condition	ResponseTime > 3000
	Warning condition	ResponseTime > 2000
Actions	Email	--
	Command	--
	SNMP	Abnormal, Warning, Normal

Related reports

Reports/SAP System/SAP Basis/Web Application Server/Troubleshooting/Recent Past/Dialog ResponseTime

Extended Memory

Overview

The Extended Memory alarm monitors the usage of extended memory.

Main settings

Alarm properties in PFM - Web Console		Setting
Item	Details	
Main Information	Product	SAP Sytem (3.0)
	Alarm message text	--
	Monitor whether the value exists	Not selected
	Enable alarm	Selected
	Alarm notification	Notify when the state changed
	Notification target	State changes for the alarm
	Evaluate all data	Not selected
	Monitoring time range	Always monitor
	Report alarm when the following damping condition is reached	Not selected
	occurrence(s) during	--
	interval(s)	--
Alarm Conditions	Record	Workload Summary Interval (PI)
	Field	EsAct %
	Abnormal condition	EsAct % > 95
	Warning condition	EsAct % > 80
Actions	Email	--
	Command	--
	SNMP	Abnormal, Warning, Normal

Related reports

Reports/SAP System/SAP Basis/Web Application Server/Troubleshooting/Recent Past/SAP Memory Used

Heap Memory

Overview

The Heap Memory alarm monitors the usage of heap memory.

Main settings

Alarm properties in PFM - Web Console		Setting
Item	Details	
Main Information	Product	SAP Sytem (3.0)
	Alarm message text	--
	Monitor whether the value exists	Not selected
	Enable alarm	Selected
	Alarm notification	Notify when the state changed
	Notification target	State changes for the alarm
	Evaluate all data	Not selected
	Monitoring time range	Always monitor
	Report alarm when the following damping condition is reached	Not selected
	occurrence(s) during	--
	interval(s)	--
Alarm Conditions	Record	Workload Summary Interval (PI)
	Field	HeapAct %
	Abnormal condition	HeapAct % > 95
	Warning condition	HeapAct % > 80
Actions	Email	--
	Command	--
	SNMP	Abnormal, Warning, Normal

Related reports

Reports/SAP System/SAP Basis/Web Application Server/Troubleshooting/Recent Past/SAP Memory Used

Paging Area

Overview

The Paging Area alarm monitors the usage of paging area.

Main settings

Alarm properties in PFM - Web Console		Setting
Item	Details	
Main Information	Product	SAP Sytem (3.0)
	Alarm message text	--
	Monitor whether the value exists	Not selected
	Enable alarm	Selected
	Alarm notification	Notify when the state changed
	Notification target	State changes for the alarm
	Evaluate all data	Not selected
	Monitoring time range	Always monitor
	Report alarm when the following damping condition is reached	Not selected
	occurrence(s) during	--
	interval(s)	--
Alarm Conditions	Record	Workload Summary Interval (PI)
	Field	R3PagingUsed %
	Abnormal condition	R3PagingUsed % > 95
	Warning condition	R3PagingUsed % > 80
Actions	Email	--
	Command	--
	SNMP	Abnormal, Warning, Normal

Related reports

Reports/SAP System/SAP Basis/Web Application Server/Troubleshooting/Recent Past/SAP Memory Used

Roll Area

Overview

The Roll Area alarm monitors the usage of roll area.

Main settings

Alarm properties in PFM - Web Console		Setting
Item	Details	
Main Information	Product	SAP Sytem (3.0)
	Alarm message text	--
	Monitor whether the value exists	Not selected
	Enable alarm	Selected
	Alarm notification	Notify when the state changed
	Notification target	State changes for the alarm
	Evaluate all data	Not selected
	Monitoring time range	Always monitor
	Report alarm when the following damping condition is reached	Not selected
	occurrence(s) during	--
	interval(s)	--
Alarm Conditions	Record	Workload Summary Interval (PI)
	Field	R3RollUsed %
	Abnormal condition	R3RollUsed % > 95
	Warning condition	R3RollUsed % > 80
Actions	Email	--
	Command	--
	SNMP	Abnormal, Warning, Normal

Related reports

Reports/SAP System/SAP Basis/Web Application Server/Troubleshooting/Recent Past/SAP Memory Used

SystemWideQueue

Overview

The SystemWideQueue alarm monitors the number of jobs waiting to be executed (average in the entire system).

Main settings

Alarm properties in PFM - Web Console		Setting
Item	Details	
Main Information	Product	SAP Sytem (3.0)
	Alarm message text	--
	Monitor whether the value exists	Not selected
	Enable alarm	Selected
	Alarm notification	Notify when the state changed
	Notification target	State changes for the alarm
	Evaluate all data	Not selected
	Monitoring time range	Always monitor
	Report alarm when the following damping condition is reached	Not selected
	occurrence(s) during	--
	interval(s)	--
Alarm Conditions	Record	Background Processing (PI_BTCP)
	Field	SystemWideQueueLength
	Abnormal condition	SystemWideQueueLength > 4
	Warning condition	SystemWideQueueLength > 2
Actions	Email	--
	Command	--
	SNMP	Abnormal, Warning, Normal

Related reports

Reports/SAP System/SAP Basis/Web Application Server/Status Reporting/Daily Trend/Advanced/Background Processing SystemWideQueue

ServerSpecificQueue

Overview

The ServerSpecificQueue alarm monitors the number of released jobs waiting to be executed.

Main settings

Alarm properties in PFM - Web Console		Setting
Item	Details	
Main Information	Product	SAP Sytem (3.0)
	Alarm message text	--
	Monitor whether the value exists	Not selected
	Enable alarm	Selected
	Alarm notification	Notify when the state changed
	Notification target	State changes for the alarm
	Evaluate all data	Not selected
	Monitoring time range	Always monitor
	Report alarm when the following damping condition is reached	Not selected
	occurrence(s) during	--
	interval(s)	--
Alarm Conditions	Record	Background Service (PI_BTC)
	Field	ServerSpecificQueueLength
	Abnormal condition	ServerSpecificQueueLength > 4
	Warning condition	ServerSpecificQueueLength > 2
Actions	Email	--
	Command	--
	SNMP	Abnormal, Warning, Normal

Related reports

Reports/SAP System/SAP Basis/Web Application Server/Status Reporting/Daily Trend/Advanced/Background Service ServerSpecificQueue

Utilization % (alarm for monitoring the average usage of background work processes)

Overview

The Utilization % alarm monitors the average usage of the server's background work processes.

Main settings

Alarm properties in PFM - Web Console		Setting
Item	Details	
Main Information	Product	SAP Sytem (3.0)
	Alarm message text	--
	Monitor whether the value exists	Not selected
	Enable alarm	Selected
	Alarm notification	Notify when the state changed
	Notification target	State changes for the alarm
	Evaluate all data	Not selected
	Monitoring time range	Always monitor
	Report alarm when the following damping condition is reached	Not selected
	occurrence(s) during	--
	interval(s)	--
Alarm Conditions	Record	Background Service (PI_BTC)
	Field	Utilization %
	Abnormal condition	Utilization % > 95
	Warning condition	Utilization % > 90
Actions	Email	--
	Command	--
	SNMP	Abnormal, Warning, Normal

Related reports

Reports/SAP System/SAP Basis/Web Application Server/Status Reporting/Daily Trend/Advanced/Background Service Utilization %

QueueLength %

Overview

The QueueLength % alarm monitors the average usage of the dispatcher queue for dialog work processes.

Main settings

Alarm properties in PFM - Web Console		Setting
Item	Details	
Main Information	Product	SAP Sytem (3.0)
	Alarm message text	--
	Monitor whether the value exists	Not selected
	Enable alarm	Selected
	Alarm notification	Notify when the state changed
	Notification target	State changes for the alarm
	Evaluate all data	Not selected
	Monitoring time range	Always monitor
	Report alarm when the following damping condition is reached	Not selected
	occurrence(s) during	--
	interval(s)	--
Alarm Conditions	Record	Dialog Service (PI_DIA)
	Field	QueueLength %
	Abnormal condition	QueueLength % > 100
	Warning condition	QueueLength % > 99
Actions	Email	--
	Command	--
	SNMP	Abnormal, Warning, Normal

Related reports

Reports/SAP System/SAP Basis/Web Application Server/Troubleshooting/Recent Past/Advanced/Dialog Utilization %

Utilization % (alarm for monitoring the average usage of dialog processes)

Overview

The Utilization % alarm monitors the average usage of the application server's dialog processes.

Main settings

Alarm properties in PFM - Web Console		Setting
Item	Details	
Main Information	Product	SAP Sytem (3.0)
	Alarm message text	--
	Monitor whether the value exists	Not selected
	Enable alarm	Selected
	Alarm notification	Notify when the state changed
	Notification target	State changes for the alarm
	Evaluate all data	Not selected
	Monitoring time range	Always monitor
	Report alarm when the following damping condition is reached	Not selected
	occurrence(s) during	--
	interval(s)	--
Alarm Conditions	Record	Dialog Service (PI_DIA)
	Field	Utilization %
	Abnormal condition	Utilization % > 100
	Warning condition	Utilization % > 99
Actions	Email	--
	Command	--
	SNMP	Abnormal, Warning, Normal

Related reports

Reports/SAP System/SAP Basis/Web Application Server/Troubleshooting/Recent Past/Advanced/Dialog Utilization %

Format of report explanations

This section describes the format used to explain reports. The manual lists the reports in alphabetical order.

Report name

Indicates the name of a report in the monitoring template.

A report name that includes (Multi-Agent) means a report that displays information about multiple instances.

A report name that does not include (Multi-Agent) means a report that displays information about a single instance.

Overview

Provides an overview of the information that can be displayed in the report.

Storage location

Indicates the storage location of the report.

When you check the reports tree in the PFM - Web Console window, replace the path beginning with `Reports/` with `System Reports/`.

Record

Indicates the record that contains the performance data used in the report. To display a historical report, you must specify information in advance in order to collect the record indicated in this column. Before displaying the report, check the Properties window to make sure that **Log** is set to **Yes**. The Properties window is displayed in PFM - Web Console when the agent icon on the **Agents** page is clicked and then the **Properties** method is clicked. This setting is not needed to display a real-time report.

Fields

Provides a table that describes the fields used in the report.

Drilldown reports (report level)

Provides a table that lists other reports in the monitoring template that are related to this report. To display this drilldown report, select in the PFM - Web Console report window the name of the desired drilldown report from the drilldown reports pull-down list, and then click **Display Reports**. Note that some reports do not have any drilldown reports.

Drilldown reports (field level)

Provides a table that describes reports in the monitoring template that are associated with fields used in this report. To display these drilldown reports, in the PFM - Web Console report window, choose **Graph**, **List**, or **Table**. In the case of a historical report, you can display drilldown reports in smaller intervals by displaying them from the time item. Note that some reports do not have any drilldown reports.

For details about drilldown reports, see the chapter that describes report creation for operation analysis in the *JPI/Performance Management User's Guide*.

Organization of report folders

The following shows the organization of the report folders for PFM - Agent for Enterprise Applications. Angle brackets enclose folder names:

```
<SAP System>
  +-- <SAP Basis/Web Application Server>
    +-- <Monthly Trend>
      |   +-- Dialog ResponseTime Trend
      |   +-- Dialog ResponseTime Trend(Multi-Agent)
      |   +-- SAP Buffer Hitratio Trend
      |   +-- SAP Memory Used Trend
      |   +-- UsersLoggedIn Trend
      |   +-- UsersLoggedIn Trend(Multi-Agent)
    +-- <Status Reporting>
      |   +-- <Daily Trend>
      |     |   +-- Dialog ResponseTime Trend
      |     |   +-- SAP Buffer Hitratio Trend
      |     |   +-- SAP Memory Used Trend
      |     |   +-- UsersLoggedIn Trend
      |     |   +-- <Advanced>
      |     |     +-- Background Processing SystemWideQueue
      |     |     +-- Background Service ServerSpecificQueue
      |     |     +-- Background Service Utilization %
      |   +-- <Real-Time>
      |     +-- Dialog ResponseTime Status
      |     +-- Process Overview Status
      |     +-- SAP Buffer Hitratio Status
      |     +-- SAP Memory Used Status
      |     +-- <Drilldown Only>
      |       +-- SAP Buffer Detail(CUA)
      |       +-- SAP Buffer Detail(FieldDescription)
      |       +-- SAP Buffer Detail(GenericKey)
      |       +-- SAP Buffer Detail(InitialRecords)
      |       +-- SAP Buffer Detail(Program)
      |       +-- SAP Buffer Detail(Screen)
      |       +-- SAP Buffer Detail(ShortNameTAB)
      |       +-- SAP Buffer Detail(SingleRecord)
      |       +-- SAP Buffer Detail(TableDefinition)
      |       +-- SAP Memory Detail
    +-- <Troubleshooting>
      |   +-- <Real-Time>
      |   +-- <Recent Past>
      |     +-- Dialog ResponseTime
      |     +-- <Advanced>
      |       +-- Dialog Utilization %
      |     +-- SAP Buffer Hitratio
      |     +-- SAP Memory Used
      |     +-- <Drilldown Only>
      |       +-- Process Detail
```

The following describes each folder:

- Monthly Trend folder

This folder contains reports that display daily information for the past month. Use the reports in this folder to check monthly trends in the system.

- **Status Reporting folder**

This folder contains reports that display daily or weekly information. Use the reports in this folder to check the overall status of the system. You can display real-time reports as well as historical reports.

- **Daily Trend folder**

This folder contains reports for displaying hourly information for the past 24 hours. Use the reports in this folder to check the daily status of the system.

- **Real-Time folder**

This folder contains real-time reports for checking the system status.

- **Troubleshooting folder**

This folder contains reports for displaying information that is useful for resolving problems. In the event of a system problem, use the reports in this folder to check the cause of the problem.

- **Real-Time folder**

This folder contains real-time reports for checking the current system status.

- **Recent Past folder**

This folder contains historical reports for displaying minute-by-minute information for the past hour.

These folders may also include the following folder:

- **Drilldown Only folder**

This folder contains reports that are displayed as drilldown reports (field level). Use it to display detailed information about fields contained in the applicable report.

List of reports

The following table lists the reports defined in the monitoring template in alphabetical order.

Table 9–2: List of reports

Category	Report name	Displayed information
Response time	Dialog ResponseTime	Analysis report in the event of a problem with the dialog task's response times over the past hour
	Dialog ResponseTime Status	Overview of the dialog task's response times
	Dialog ResponseTime Trend (hourly historical report)	Trends in the dialog task's response times over the past 24 hours (hourly)
	Dialog ResponseTime Trend (daily historical report)	Trends in the dialog task's response times over the past month (daily)
	Dialog ResponseTime Trend (Multi-Agent)	Trends in the dialog task's response times over the past month (comparison among application servers)
Work process	Background Service Utilization %	Trends in the average usage of the server's background processes over the past 24 hours (hourly)
	Dialog Utilization %	Analysis report in the event of a problem with dialog work processes over the past hour (minute-by-minute)
	Process Detail	Work process activity status over the past hour
	Process Overview Status	Work process activity status
SAP buffer	SAP Buffer Detail (CUA)	Details of the SAP buffer (CUA buffer) (drilldown report)
	SAP Buffer Detail (FieldDescription)	Details of the SAP buffer (field description buffer) (drilldown report)
	SAP Buffer Detail (GenericKey)	Details of the SAP buffer (generic key buffer) (drilldown report)
	SAP Buffer Detail (InitialRecords)	Details of the SAP buffer (initial records buffer) (drilldown report)
	SAP Buffer Detail (Program)	Details of the SAP buffer (program buffer) (drilldown report)
	SAP Buffer Detail (Screen)	Details of the SAP buffer (screen buffer) (drilldown report)
	SAP Buffer Detail (ShortNameTAB)	Details of the SAP buffer (short nametab buffer) (drilldown report)
	SAP Buffer Detail (SingleRecord)	Details of the SAP buffer (single record buffer) (drilldown report)
	SAP Buffer Detail (TableDefinition)	Details of the SAP buffer (table definition buffer) (drilldown report)
	SAP Buffer Hitratio	Analysis report in the event of a problem with the SAP buffer hit rate over the past hour
	SAP Buffer Hitratio Status	Overview of the SAP buffer hit rate
	SAP Buffer Hitratio Trend (hourly historical report)	Trends in the SAP buffer hit rate over the past 24 hours (hourly)

Category	Report name	Displayed information
SAP buffer	SAP Buffer Hitratio Trend (daily historical report)	Trends in the SAP buffer hit rate over the past month (daily)
SAP memory	SAP Memory Detail	Details of the SAP memory
	SAP Memory Used	Analysis report in the event of a problem with the SAP memory usage over the past hour
	SAP Memory Used Status	Overview of the SAP memory usage
	SAP Memory Used Trend (hourly historical report)	Trends in the SAP memory usage over the past 24 hours (hourly)
	SAP Memory Used Trend (daily historical report)	Trends in the SAP memory usage over the past month (daily)
Login user	UsersLoggedIn Trend (hourly historical report)	Trends in the number of users logged on over the past 24 hours (hourly)
	UsersLoggedIn Trend (daily historical report)	Trends in the number of users logged on over the past month (daily)
	UsersLoggedIn Trend (Multi-Agent)	Trends in the number of users logged on over the past month (comparison among application servers)
Trends in the number of jobs	Background Processing SystemWideQueue	Trends in the number of jobs waiting to be executed over the past 24 hours (average in the entire system) (minute-by-minute)
	Background Service ServerSpecificQueue	Trends in the number of released jobs waiting to be executed over the past 24 hours (hourly)

Dialog ResponseTime

Overview

The `Dialog ResponseTime` report displays an analysis report in the event of a problem with the dialog task's response times. It displays minute-by-minute trends in the response times over the past hour. The display format is a table and a line graph.

Storage location

Reports/SAP System/SAP Basis/Web Application Server/Troubleshooting/Recent Past/

Record

WorkLoad Summary Interval (PI)

Fields

Field name	Description
DBRequestTime	Average time (in milliseconds) required to process logical database requests
DialogSteps	Average number of dialog steps per minute
FrontendResponseTime	Average time the user waits at the front end for a request to be processed. This is the average (in milliseconds) of the total of the response time, network transfer time, and front-end processing time.
Instance Name	SAP instance name. This name usually consists of a host name, SAP system ID, and system number. The setting can be changed by the <code>rdisp/myname</code> parameter.
Load+GenTime	Average time required (in milliseconds) for loading and creating source text, graphical user interface, and window information from the database
QueueTime	Average wait time in the dispatcher queue. This is the average time (in milliseconds) user requests remain in the dispatcher queue.
ResponseTime	Average time (in milliseconds) required to process dialog steps. This is the total processing time required for a dialog step, and it includes the database processing time but not the network transfer time or front-end processing time.
System ID	SAP system ID

Drilldown reports (report level)

Report name	Description
Process Detail	Displays the activity status of the work process over the past hour.

Dialog ResponseTime Status

Overview

The Dialog ResponseTime Status report displays an overview of the dialog task's response times in real-time. The display format is a list and a line graph.

Storage location

Reports/SAP System/SAP Basis/Web Application Server/Status Reporting/Real-Time/

Record

Dialog Service (PI_DIA)

Fields

Field name	Description
FrontendNetTime	Network time (in milliseconds) used for the first data transfer from front end to application server and for the last data transfer from application server to front end. This does not include the value of the GuiCallBackTime field.
Instance Name	SAP instance name. This name usually consists of a host name, SAP system ID, and system number. The setting can be changed by the <code>rdisp/myname</code> parameter.
ResponseTime	Average time (in milliseconds) required to process dialog steps. This is the total processing time required for a dialog step, and it includes the database processing time but not the network transfer time or front-end processing time.
ResponseTime:StandardTran.	Standard transaction's response time (in milliseconds)
System ID	SAP system ID
UsersLoggedIn	Number of users currently logged on

Dialog ResponseTime Trend (hourly historical report)

Overview

The Dialog ResponseTime Trend report displays hourly trends in the dialog task's response times over the past 24 hours. The display format is a table and a line graph.

You can display minute-by-minute drilldown reports from the displayed data in order to view more detailed data for specific time periods.

Storage location

Reports/SAP System/SAP Basis/Web Application Server/Status Reporting/Daily Trend/

Record

WorkLoad Summary Interval (PI)

Fields

Field name	Description
DBRequestTime	Average time (in milliseconds) required to process logical database requests
DialogSteps	Average number of dialog steps per minute
FrontendResponseTime	Average time the user waits at the front end for a request to be processed. This is the average (in milliseconds) of the total of the response time, network transfer time, and front-end processing time.
Instance Name	SAP instance name. This name usually consists of a host name, SAP system ID, and system number. The setting can be changed by the <code>rdisp/myname</code> parameter.
Load+GenTime	Average time required (in milliseconds) for loading and creating source text, graphical user interface, and window information from the database
QueueTime	Average wait time in the dispatcher queue. This is the average time (in milliseconds) user requests remain in the dispatcher queue.
ResponseTime	Average time (in milliseconds) required to process dialog steps. This is the total processing time required for a dialog step, and it includes the database processing time but not the network transfer time or front-end processing time.
System ID	SAP system ID

Dialog ResponseTime Trend (daily historical report)

Overview

The Dialog ResponseTime Trend report displays daily trends in the dialog task's response times over the past month. The display format is a list and a line graph.

Storage location

Reports/SAP System/SAP Basis/Web Application Server/Monthly Trend/

Record

WorkLoad Summary Interval (PI)

Fields

Field name	Description
DBRequestTime	Average time (in milliseconds) required to process logical database requests
DialogSteps	Average number of dialog steps per minute
FrontendResponseTime	Average time the user waits at the front end for a request to be processed. This is the average (in milliseconds) of the total of the response time, network transfer time, and front-end processing time.
Instance Name	SAP instance name. This name usually consists of a host name, SAP system ID, and system number. The setting can be changed by the <code>rdisp/myname</code> parameter.
Load+GenTime	Average time required (in milliseconds) for loading and creating source text, graphical user interface, and window information from the database
QueueTime	Average wait time in the dispatcher queue. This is the average time (in milliseconds) user requests remain in the dispatcher queue.
ResponseTime	Average time (in milliseconds) required to process dialog steps. This is the total processing time required for a dialog step, and it includes the database processing time but not the network transfer time or front-end processing time.
System ID	SAP system ID

Dialog ResponseTime Trend (Multi-Agent)

Overview

The Dialog ResponseTime Trend (Multi-Agent) report compares trends among application servers in the dialog task's response times over the past month. The display format is a list and a line graph.

Storage location

Reports/SAP System/SAP Basis/Web Application Server/Monthly Trend/

Record

WorkLoad Summary Interval (PI)

Fields

Field name	Description
DBRequestTime	Average time (in milliseconds) required to process logical database requests
DialogSteps	Average number of dialog steps per minute
FrontendResponseTime	Average time the user waits at the front end for a request to be processed. This is the average (in milliseconds) of the total of the response time, network transfer time, and front-end processing time.
Agent Instance	Instance name of PFM - Agent
Load+GenTime	Average time required (in milliseconds) for loading and creating source text, graphical user interface, and window information from the database
QueueTime	Average wait time in the dispatcher queue. This is the average time (in milliseconds) user requests remain in the dispatcher queue.
ResponseTime	Average time (in milliseconds) required to process dialog steps. This is the total processing time required for a dialog step, and it includes the database processing time but not the network transfer time or front-end processing time.
System ID	SAP system ID

Dialog Utilization %

Overview

The Dialog Utilization % report displays an analysis report in the event of a problem with dialog work processes. It displays minute-by-minute trends in the dialog work processes over the past hour.

Storage location

Reports/SAP System/SAP Basis/Web Application Server/Troubleshooting/Recent Past/Advanced/

Record

Dialog Service (PI_DIA)

Fields

Field name	Description
Instance Name	SAP instance name. This name usually consists of a host name, SAP system ID, and system number. The setting can be changed by the <code>rdisp/myname</code> parameter.
QueueLength %	Average usage of the dispatcher queue for dialog work processes
Utilization %	Average usage of the application server's dialog processes
System ID	SAP system ID

Process Detail

Overview

The `Process Detail` report displays the activity status of a work process over the past hour. The display format is a list. This is a drilldown report.

Storage location

Reports/SAP System/SAP Basis/Web Application Server/Troubleshooting/Recent Past/Drilldown Only/

Record

Work Process Summary (PD)

Fields

Field name	Description
Action	Applicable activity name of the work process
Bname	User name of the request that is currently being processed by the work process
CPU	Reserved field; cannot be used
Dumps	Number of times the work process terminated abnormally
ELTime	Duration of the work process (in seconds)
Instance Name	SAP instance name. This name usually consists of a host name, SAP system ID, and system number. The setting can be changed by the <code>rdisp/myname</code> parameter.
ManDt	Client name of the request that is currently being processed by the work process
No	Work process number
Pid	ID of the work process in the host system
Report	Name of the report the work process is executing
Restart	Y (re-execute) or N (do not re-execute), indicating whether the work process will be re-executed automatically in the event of abnormal termination.
Sem	Semaphore number where the work process is in wait status
Status	Current status of the work process (example: <code>Waiting</code> or <code>Running</code>)
System ID	SAP system ID
Table	Name of the last database table accessed by the work process
Typ	Type of work process (such as <code>DIA</code> , <code>UPD</code> , <code>UP2</code> , <code>ENQ</code> , <code>BGD</code> , or <code>SPO</code>).
Waiting	Reason why the work process is waiting

Process Overview Status

Overview

The Process Overview Status report displays the activity status of a work process in real-time. The display format is a table.

Storage location

Reports/SAP System/SAP Basis/Web Application Server/Status Reporting/Real-Time/

Record

Work Process Summary (PD)

Fields

Field name	Description
Action	Applicable activity name of the work process
Bname	User name of the request that is currently being processed by the work process
CPU	Reserved field; cannot be used
Dumps	Number of times the work process terminated abnormally
ELTime	Duration of the work process (in seconds)
Instance Name	SAP instance name. This name usually consists of a host name, SAP system ID, and system number. The setting can be changed by the <code>rdisp/myname</code> parameter.
ManDt	Client name of the request that is currently being processed by the work process
No	Work process number
Pid	ID of the work process in the host system
Report	Name of the report the work process is executing
Restart	Y (re-execute) or N (do not re-execute), indicating whether the work process will be re-executed automatically in the event of abnormal termination.
Sem	Semaphore number where the work process is in wait status
Status	Current status of the work process (example: Running or Waiting)
System ID	SAP system ID
Table	Name of the last database table accessed by the work process
Typ	Type of work process (such as DIA, UPD, UP2, ENQ, BGD, or SPO).
Waiting	Reason why the work process is waiting

SAP Buffer Detail (CUA)

Overview

The SAP Buffer Detail (CUA) report displays the details of the SAP buffer (CUA buffer) in real-time. The display format is a list. This is a drilldown report.

Storage location

Reports/SAP System/SAP Basis/Web Application Server/Status Reporting/Real-Time/Drilldown Only/

Record

SAP Buffer Summary (PI_BUFF)

Fields

Field name	Description
CUA DirectoryUsed %	Usage of the CUA buffer directory (number of entries)
CUA HitRatio %	Percentage of the database queries that were not passed to the database because they were found in the CUA buffer
CUA SpaceUsed %	Usage of the CUA buffer storage
CUA Swap	Number of times swapping occurred in the CUA buffer per minute because the buffer was full
Instance Name	SAP instance name. This name usually consists of a host name, SAP system ID, and system number. The setting can be changed by the <code>rdisp/myname</code> parameter.
System ID	SAP system ID

SAP Buffer Detail (FieldDescription)

Overview

The SAP Buffer Detail (FieldDescription) report displays the details of the SAP buffer (field description buffer) in real-time. The display format is a list. This is a drilldown report.

Storage location

Reports/SAP System/SAP Basis/Web Application Server/Status Reporting/Real-Time/Drilldown Only/

Record

SAP Buffer Summary (PI_BUFF)

Fields

Field name	Description
FieldDescription DirectoryUsed %	Usage of the field description buffer directory (number of entries)
FieldDescription HitRatio %	Percentage of the database queries that were not passed to the database because they were found in the field description buffer
FieldDescription SpaceUsed %	Usage of the field description buffer storage
FieldDescription Swap	Number of times swapping occurred in the field description buffer per minute because the buffer was full
Instance Name	SAP instance name. This name usually consists of a host name, SAP system ID, and system number. The setting can be changed by the <code>rdisp/myname</code> parameter.
System ID	SAP system ID

SAP Buffer Detail (GenericKey)

Overview

The SAP Buffer Detail (GenericKey) report displays the details of the SAP buffer (generic key buffer) in real-time. The display format is a list. This is a drilldown report.

Storage location

Reports/SAP System/SAP Basis/Web Application Server/Status Reporting/Real-Time/Drilldown Only/

Record

SAP Buffer Summary (PI_BUFF)

Fields

Field name	Description
GenericKey DirectoryUsed %	Usage of the generic key buffer directory (number of entries)
GenericKey HitRatio %	Percentage of the database queries that were not passed to the database because they were found in the generic key buffer
GenericKey SpaceUsed %	Usage of the generic key buffer storage
GenericKey Swap	Number of times swapping occurred in the generic key buffer per minute because the buffer was full
Instance Name	SAP instance name. This name usually consists of a host name, SAP system ID, and system number. The setting can be changed by the <code>rdisp/myname</code> parameter.
System ID	SAP system ID

SAP Buffer Detail (InitialRecords)

Overview

The SAP Buffer Detail (InitialRecords) report displays the details of the SAP buffer (initial records buffer) in real-time. The display format is a list. This is a drilldown report.

Storage location

Reports/SAP System/SAP Basis/Web Application Server/Status Reporting/Real-Time/Drilldown Only/

Record

SAP Buffer Summary (PI_BUFF)

Fields

Field name	Description
InitialRecords DirectoryUsed %	Usage of the initial records buffer directory (number of entries)
InitialRecords HitRatio %	Percentage of the database queries that were not passed to the database because they were found in the initial records buffer
InitialRecords SpaceUsed %	Usage of the initial records buffer storage
InitialRecords Swap	Number of times swapping occurred in the initial records buffer per minute because the buffer was full
Instance Name	SAP instance name. This name usually consists of a host name, SAP system ID, and system number. The setting can be changed by the <code>rdisp/myname</code> parameter.
System ID	SAP system ID

SAP Buffer Detail (Program)

Overview

The SAP Buffer Detail (Program) report displays the details of the SAP buffer (program buffer) in real-time. The display format is a list. This is a drilldown report.

Storage location

Reports/SAP System/SAP Basis/Web Application Server/Status Reporting/Real-Time/Drilldown Only/

Record

SAP Buffer Summary (PI_BUFF)

Fields

Field name	Description
Instance Name	SAP instance name. This name usually consists of a host name, SAP system ID, and system number. The setting can be changed by the <code>rdisp/myname</code> parameter.
Program DirectoryUsed %	Usage of the program buffer directory (number of entries)
Program HitRatio %	Percentage of the database queries that were not passed to the database because they were found in the program buffer
Program SpaceUsed %	Usage of the program buffer storage
Program Swap	Number of times swapping occurred in the program buffer per minute because the buffer was full
System ID	SAP system ID

SAP Buffer Detail (Screen)

Overview

The SAP Buffer Detail (Screen) report displays the details of the SAP buffer (screen buffer) in real-time. The display format is a list. This is a drilldown report.

Storage location

Reports/SAP System/SAP Basis/Web Application Server/Status Reporting/Real-Time/Drilldown Only/

Record

SAP Buffer Summary (PI_BUFF)

Fields

Field name	Description
Instance Name	SAP instance name. This name usually consists of a host name, SAP system ID, and system number. The setting can be changed by the <code>rdisp/myname</code> parameter.
Screen DirectoryUsed %	Usage of the screen buffer directory (number of entries)
Screen HitRatio %	Percentage of the database queries that were not passed to the database because they were found in the screen buffer
Screen SpaceUsed %	Usage of the screen buffer storage
Screen Swap	Number of times swapping occurred in the screen buffer per minute because the buffer was full
System ID	SAP system ID

SAP Buffer Detail (ShortNameTAB)

Overview

The SAP Buffer Detail (ShortNameTAB) report displays the details of the SAP buffer (short nametab buffer) in real-time. The display format is a list. This is a drilldown report.

Storage location

Reports/SAP System/SAP Basis/Web Application Server/Status Reporting/Real-Time/Drilldown Only/

Record

SAP Buffer Summary (PI_BUFF)

Fields

Field name	Description
Instance Name	SAP instance name. This name usually consists of a host name, SAP system ID, and system number. The setting can be changed by the <code>rdisp/myname</code> parameter.
ShortNameTAB DirectoryUsed %	Usage of the short nametab buffer directory (number of entries)
ShortNameTAB HitRatio %	Percentage of the database queries that were not passed to the database because they were found in the short nametab buffer
ShortNameTAB SpaceUsed %	Usage of the short nametab buffer storage
ShortNameTAB Swap	Number of times swapping occurred in the short nametab buffer per minute because the buffer was full
System ID	SAP system ID

SAP Buffer Detail (SingleRecord)

Overview

The SAP Buffer Detail (SingleRecord) report displays the details of the SAP buffer (single record buffer) in real-time. The display format is a list. This is a drilldown report.

Storage location

Reports/SAP System/SAP Basis/Web Application Server/Status Reporting/Real-Time/Drilldown Only/

Record

SAP Buffer Summary (PI_BUFF)

Fields

Field name	Description
Instance Name	SAP instance name. This name usually consists of a host name, SAP system ID, and system number. The setting can be changed by the <code>rdisp/myname</code> parameter.
SingleRecord DirectoryUsed %	Usage of the single record buffer directory (number of entries)
SingleRecord HitRatio %	Ratio (percentage) of the database queries that were not passed to the database because the data was found in the single record buffer
SingleRecord SpaceUsed %	Usage of the single record buffer storage
SingleRecord Swap	Number of times swapping occurred in the single record buffer per minute because the buffer was full
System ID	SAP system ID

SAP Buffer Detail (TableDefinition)

Overview

The SAP Buffer Detail (TableDefinition) report displays the details of the SAP buffer (table definition buffer) in real-time. The display format is a list. This is a drilldown report.

Storage location

Reports/SAP System/SAP Basis/Web Application Server/Status Reporting/Real-Time/Drilldown Only/

Record

SAP Buffer Summary (PI_BUFF)

Fields

Field name	Description
Instance Name	SAP instance name. This name usually consists of a host name, SAP system ID, and system number. The setting can be changed by the <code>rdisp/myname</code> parameter.
System ID	SAP system ID
TableDefinition DirectoryUsed %	Usage of the table definition buffer directory (number of entries)
TableDefinition HitRatio %	Percentage of the database queries that were not passed to the database because they were found in the table definition buffer
TableDefinition SpaceUsed %	Usage of the table definition buffer storage
TableDefinition Swap	Number of times swapping occurred in the table definition buffer per minute because the buffer was full

SAP Buffer Hitratio

Overview

The `SAP Buffer Hitratio` report displays an analysis report in the event of a problem with the SAP buffer hit rate. It displays minute-by-minute trends in the SAP buffer hit rate over the past hour. The display format is a table and a line graph.

Storage location

Reports/SAP System/SAP Basis/Web Application Server/Troubleshooting/Recent Past/

Record

WorkLoad Summary Interval (PI)

Fields

Field name	Description
CUA HitRatio %	Percentage of the database queries that were not passed to the database because they were found in the CUA buffer
FieldDescription HitRatio %	Percentage of the database queries that were not passed to the database because they were found in the field description buffer
GenericKey HitRatio %	Percentage of the database queries that were not passed to the database because they were found in the generic key buffer
InitialRecords HitRatio %	Percentage of the database queries that were not passed to the database because they were found in the initial records buffer
Instance Name	SAP instance name. This name usually consists of a host name, SAP system ID, and system number. The setting can be changed by the <code>rdisp/myname</code> parameter.
Program HitRatio %	Percentage of the database queries that were not passed to the database because they were found in the program buffer
Screen HitRatio %	Percentage of the database queries that were not passed to the database because they were found in the screen buffer
ShortNameTAB HitRatio %	Percentage of the database queries that were not passed to the database because they were found in the short nametab buffer
SingleRecord HitRatio %	Percentage of the database queries that were not passed to the database because they were found in the single record buffer
System ID	SAP system ID
TableDefinition HitRatio %	Percentage of the database queries that were not passed to the database because they were found in the table definition buffer

Drilldown reports (report level)

Report name	Description
Process Detail	Displays the activity status of the work process over the past hour.

SAP Buffer Hitratio Status

Overview

The SAP Buffer Hitratio Status report displays an overview of the SAP buffer hit rate in real-time. The display format is a list and a line graph.

Storage location

Reports/SAP System/SAP Basis/Web Application Server/Status Reporting/Real-Time/

Record

SAP Buffer Summary (PI_BUFF)

Fields

Field name	Description
CUA HitRatio %	Percentage of the database queries that were not passed to the database because they were found in the CUA buffer
FieldDescription HitRatio %	Percentage of the database queries that were not passed to the database because they were found in the field description buffer
GenericKey HitRatio %	Percentage of the database queries that were not passed to the database because they were found in the generic key buffer
InitialRecords HitRatio %	Percentage of the database queries that were not passed to the database because they were found in the initial records buffer
Instance Name	SAP instance name. This name usually consists of a host name, SAP system ID, and system number. The setting can be changed by the <code>rdisp/myname</code> parameter.
Program HitRatio %	Percentage of the database queries that were not passed to the database because they were found in the program buffer
Screen HitRatio %	Percentage of the database queries that were not passed to the database because they were found in the screen buffer
ShortNameTAB HitRatio %	Percentage of the database queries that were not passed to the database because they were found in the short nametab buffer
SingleRecord HitRatio %	Percentage of the database queries that were not passed to the database because they were found in the single record buffer
System ID	SAP system ID
TableDefinition HitRatio %	Percentage of the database queries that were not passed to the database because they were found in the table definition buffer

Drilldown reports (field level)

Report name	Description
SAP Buffer Detail (CUA)	Displays details of an SAP buffer (CUA buffer) in real-time. To display this report, click the CUA HitRatio % field.
SAP Buffer Detail (FieldDescription)	Displays details of an SAP buffer (field description buffer) in real-time. To display this report, click the FieldDescription HitRatio % field.

Report name	Description
SAP Buffer Detail (GenericKey)	Displays details of an SAP buffer (generic key buffer) in real-time. To display this report, click the GenericKey HitRatio % field.
SAP Buffer Detail (InitialRecords)	Displays details of an SAP buffer (initial records buffer) in real-time. To display this report, click the InitialRecords HitRatio % field.
SAP Buffer Detail (Program)	Displays details of an SAP buffer (program buffer) in real-time. To display this report, click the Program HitRatio % field.
SAP Buffer Detail (Screen)	Displays details of an SAP buffer (screen buffer) in real-time. To display this report, click the Screen HitRatio % field.
SAP Buffer Detail (ShortNameTAB)	Displays details of an SAP buffer (short nametab buffer) in real-time. To display this report, click the ShortNameTAB HitRatio % field.
SAP Buffer Detail (SingleRecord)	Displays details of an SAP buffer (single record buffer) in real-time. To display this report, click the SingleRecord HitRatio % field.
SAP Buffer Detail (TableDefinition)	Displays details of an SAP buffer (table definition buffer) in real-time. To display this report, click the TableDefinition HitRatio % field.

SAP Buffer Hitratio Trend (hourly historical report)

Overview

The SAP Buffer Hitratio Trend report displays the hourly trends in the SAP buffer hit rate over the past 24 hours. The display format is a table and a line graph.

You can display minute-by-minute drilldown reports from the displayed data in order to view more detailed data for specific time periods.

Storage location

Reports/SAP System/SAP Basis/Web Application Server/Status Reporting/Daily Trend/

Record

WorkLoad Summary Interval (PI)

Fields

Field name	Description
CUA HitRatio %	Percentage of the database queries that were not passed to the database because they were found in the CUA buffer
FieldDescription HitRatio %	Percentage of the database queries that were not passed to the database because they were found in the field description buffer
GenericKey HitRatio %	Percentage of the database queries that were not passed to the database because they were found in the generic key buffer
InitialRecords HitRatio %	Percentage of the database queries that were not passed to the database because they were found in the initial records buffer
Instance Name	SAP instance name. This name usually consists of a host name, SAP system ID, and system number. The setting can be changed by the <code>rdisp/myname</code> parameter.
Program HitRatio %	Percentage of the database queries that were not passed to the database because they were found in the program buffer
Screen HitRatio %	Percentage of the database queries that were not passed to the database because they were found in the screen buffer
ShortNameTAB HitRatio %	Percentage of the database queries that were not passed to the database because they were found in the short nametab buffer
SingleRecord HitRatio %	Percentage of the database queries that were not passed to the database because they were found in the single record buffer
System ID	SAP system ID
TableDefinition HitRatio %	Percentage of the database queries that were not passed to the database because they were found in the table definition buffer

SAP Buffer Hitratio Trend (daily historical report)

Overview

The SAP Buffer Hitratio Trend report displays the daily trends in the SAP buffer hit rate over the past month. The display format is a list and a line graph.

Storage location

Reports/SAP System/SAP Basis/Web Application Server/Monthly Trend/

Record

WorkLoad Summary Interval (PI)

Fields

Field name	Description
CUA HitRatio %	Percentage of the database queries that were not passed to the database because they were found in the CUA buffer
FieldDescription HitRatio %	Percentage of the database queries that were not passed to the database because they were found in the field description buffer
GenericKey HitRatio %	Percentage of the database queries that were not passed to the database because they were found in the generic key buffer
InitialRecords HitRatio %	Percentage of the database queries that were not passed to the database because they were found in the initial records buffer
Instance Name	SAP instance name. This name usually consists of a host name, SAP system ID, and system number. The setting can be changed by the <code>rdisp/myname</code> parameter.
Program HitRatio %	Percentage of the database queries that were not passed to the database because they were found in the program buffer
Screen HitRatio %	Percentage of the database queries that were not passed to the database because they were found in the screen buffer
ShortNameTAB HitRatio %	Percentage of the database queries that were not passed to the database because they were found in the short nametab buffer
SingleRecord HitRatio %	Percentage of the database queries that were not passed to the database because they were found in the single record buffer
System ID	SAP system ID
TableDefinition HitRatio %	Percentage of the database queries that were not passed to the database because they were found in the table definition buffer

SAP Memory Detail

Overview

The SAP Memory Detail report displays the details of the SAP memory in real-time. The display format is a list. This is a drilldown report.

Storage location

Reports/SAP System/SAP Basis/Web Application Server/Status Reporting/Real-Time/Drilldown Only/

Record

SAP Memory Summary (PI_MEM)

Fields

Field name	Description
EmSlotsAct %	Current usage of the expansion memory slots
EmSlotsTotal	Total number of expansion memory slots
EsAct %	Current expansion memory usage
EsAttached %	Usage of the attached expansion memory
EsTotal	Size (in megabytes) of the expansion memory
HeapAct %	Current heap area usage
HeapTotal	Total size (in megabytes) of the heap area
Instance Name	SAP instance name. This name usually consists of a host name, SAP system ID, and system number. The setting can be changed by the <code>rdisp/myname</code> parameter.
PrivWpNo	Number of work processes that were placed in the PRIV mode
R3PagingUsed %	Paging area usage
R3RollUsed %	Roll area usage
System ID	SAP system ID
WpDiaRestart	Number of dialog work processes with <code>restart=Yes</code> specified
WpNonDiaRestart	Number of dialog work processes with <code>restart=No</code> specified

SAP Memory Used

Overview

The `SAP Memory Used` report displays an analysis report in the event of a problem with the SAP memory usage. It displays the minute-by-minute trends in the SAP memory usage over the past hour. The display format is a table and a line graph.

Storage location

Reports/SAP System/SAP Basis/Web Application Server/Troubleshooting/Recent Past/

Record

WorkLoad Summary Interval (PI)

Fields

Field name	Description
EsAct %	Current expansion memory usage
HeapAct %	Current heap area usage
Instance Name	SAP instance name. This name usually consists of a host name, SAP system ID, and system number. The setting can be changed by the <code>rdisp/myname</code> parameter.
R3PagingUsed %	Paging area usage
R3RollUsed %	Roll area usage
System ID	SAP system ID

Drilldown reports (report level)

Report name	Description
Process Detail	Displays the activity status of the work process over the past hour.

SAP Memory Used Status

Overview

The SAP Memory Used Status report displays an overview of the SAP memory usage in real-time. The display format is a list and a line graph.

Storage location

Reports/SAP System/SAP Basis/Web Application Server/Status Reporting/Real-Time/

Record

SAP Memory Summary (PI_MEM)

Fields

Field name	Description
EsAct %	Current expansion memory usage
HeapAct %	Current heap area usage
Instance Name	SAP instance name. This name usually consists of a host name, SAP system ID, and system number. The setting can be changed by the <code>rdisp/myname</code> parameter.
R3PagingUsed %	Paging area usage
R3RollUsed %	Roll area usage
System ID	SAP system ID

Drilldown reports (field level)

Report name	Description
SAP Memory Detail	Displays details of the SAP memory in real-time. To display this report, click the EsAct %, HeapAct %, R3PagingUsed %, or R3RollUsed % field.

SAP Memory Used Trend (hourly historical report)

Overview

The SAP Memory Used Trend report displays hourly trends in the SAP memory usage over the past 24 hours. The display format is a table and a line graph. You can display minute-by-minute drilldown reports from the displayed data in order to view more detailed data in specific time periods.

Storage location

Reports/SAP System/SAP Basis/Web Application Server/Status Reporting/Daily Trend/

Record

WorkLoad Summary Interval (PI)

Fields

Field name	Description
EsAct %	Current expansion memory usage
HeapAct %	Current heap area usage
Instance Name	SAP instance name. This name usually consists of a host name, SAP system ID, and system number. The setting can be changed by the <code>rdisp/myname</code> parameter.
R3PagingUsed %	Paging area usage
R3RollUsed %	Roll area usage
System ID	SAP system ID

SAP Memory Used Trend (daily historical report)

Overview

The SAP Memory Used Trend report displays the daily trends in the SAP memory usage over the past month. The display format is a list and a line graph.

Storage location

Reports/SAP System/SAP Basis/Web Application Server/Monthly Trend/

Record

WorkLoad Summary Interval (PI)

Fields

Field name	Description
EsAct %	Current expansion memory usage
HeapAct %	Current heap area usage
Instance Name	SAP instance name. This name usually consists of a host name, SAP system ID, and system number. The setting can be changed by the <code>rdisp/myname</code> parameter.
R3PagingUsed %	Paging area usage
R3RollUsed %	Roll area usage
System ID	SAP system ID

UsersLoggedIn Trend (hourly historical report)

Overview

The `UsersLoggedIn` Trend report displays the trends in the number of users logged on over the past 24 hours. This report displays maximum and minimum values as well as average values. The display format is a table and a line graph. You can display minute-by-minute drilldown reports from the displayed data in order to view more detailed data in specific time periods.

Storage location

Reports/SAP System/SAP Basis/Web Application Server/Status Reporting/Daily Trend/

Record

WorkLoad Summary Interval (PI)

Fields

Field name	Description
Instance Name	SAP instance name. This name usually consists of a host name, SAP system ID, and system number. The setting can be changed by the <code>rdisp/myname</code> parameter.
System ID	SAP system ID
UsersLoggedIn	Number of users currently logged on
UsersLoggedIn (Max)	Maximum number of users that have logged on
UsersLoggedIn (Min)	Minimum number of users that have logged on

UsersLoggedIn Trend (daily historical report)

Overview

The `UsersLoggedIn Trend` report displays the daily trends in the number of users logged on over the past month. This report displays maximum and minimum values as well as average values. The display format is a list and a line graph.

Storage location

Reports/SAP System/SAP Basis/Web Application Server/Monthly Trend/

Record

WorkLoad Summary Interval (PI)

Fields

Field name	Description
Instance Name	SAP instance name. This name usually consists of a host name, SAP system ID, and system number. The setting can be changed by the <code>rdisp/myname</code> parameter.
System ID	SAP system ID
UsersLoggedIn	Number of users currently logged on
UsersLoggedIn (Max)	Maximum number of users that have logged on
UsersLoggedIn (Min)	Minimum number of users that have logged on

UsersLoggedIn Trend (Multi-Agent)

Overview

The UsersLoggedIn Trend (Multi-Agent) report compares among application servers the trends in the number of users logged on over the past month. The display format is a list and a line graph.

Storage location

Reports/SAP System/SAP Basis/Web Application Server/Monthly Trend/

Record

WorkLoad Summary Interval (PI)

Fields

Field name	Description
Instance Name	SAP instance name. This name usually consists of a host name, SAP system ID, and system number. The setting can be changed by the <code>rdisp/myname</code> parameter.
System ID	SAP system ID
UsersLoggedIn	Number of users currently logged on
UsersLoggedIn (Max)	Maximum number of users that have logged on
UsersLoggedIn (Min)	Minimum number of users that have logged on

Background Processing SystemWideQueue

Overview

The Background Processing SystemWideQueue report displays hourly trends in the number of jobs waiting to be executed over the past 24 hours (average in the entire system).

Storage location

Reports/SAP System/SAP Basis/Web Application Server/Status Reporting/Daily Trend/Advanced/

Record

Background Processing (PI_BTCP)

Fields

Field name	Description
Instance Name	SAP instance name. This name usually consists of a host name, SAP system ID, and system number. The setting can be changed by the <code>rdisp/myname</code> parameter.
SystemWideQueueLength	Number of jobs waiting to be executed (average in the entire system)
System ID	SAP system ID

Background Service ServerSpecificQueue

Overview

The Background Service ServerSpecificQueue report displays hourly trends in the number of released jobs waiting to be executed over the past 24 hours.

Storage location

Reports/SAP System/SAP Basis/Web Application Server/Status Reporting/Daily Trend/Advanced/

Record

Background Service (PI_BTC)

Fields

Field name	Description
Instance Name	SAP instance name. This name usually consists of a host name, SAP system ID, and system number. The setting can be changed by the <code>rdisp/myname</code> parameter.
ServerSpecificQueueLength	Number of released jobs waiting to be executed
System ID	SAP system ID

Background Service Utilization %

Overview

The Background Service Utilization % report displays hourly trends in the average usage of the server's background processes over the past 24 hours.

Storage location

Reports/SAP System/SAP Basis/Web Application Server/Status Reporting/Daily Trend/Advanced/

Record

Background Service (PI_BTC)

Fields

Field name	Description
Instance Name	SAP instance name. This name usually consists of a host name, SAP system ID, and system number. The setting can be changed by the <code>rdisp/myname</code> parameter.
System ID	SAP system ID
Utilization %	Average usage of the server's background work processes

10

Records

This chapter describes the records for PFM - Agent for Enterprise Applications.

For details about how to collect performance data for each type of record, see the chapter that describes the functions of Performance Management in the *JP1/Performance Management Planning and Configuration Guide* or the chapter that describes management of operation monitoring data in the *JP1/Performance Management User's Guide*.

Data model

Each PFM - Agent's records and fields are referred to collectively as a *data model*. There is a specific version number for each PFM - Agent and its data model. The data model for PFM - Agent for Enterprise Applications is 5.0.

The version of each PFM - Agent's data model is displayed in the Properties window of PFM - Web Console, which is displayed when the agent icon on the **Agents** page is clicked and then the **Properties** method is clicked.

For details about the data model, see the chapter that describes the functions of Performance Management in the *JP1/Performance Management Planning and Configuration Guide*.

Format of record explanations

This chapter describes the records for PFM - Agent for Enterprise Applications in alphabetical order. Each record explanation contains the following subsections:

Function

Provides an overview of the performance data that is stored in the record and includes important information to be noted.

Default and changeable values

Consists of a table of the default values for the performance data under the collection conditions that are defined for the record, and indicates whether the values can be changed by the user. The table below lists and describes the items that are presented in *Default and changeable values*. For details about each item described in this table, see the chapter that describes management of operation monitoring data in the *JP1/Performance Management User's Guide*.

Item	Description	Changeable
Collection Interval	Performance data collection interval (in seconds)	Y: Changeable
Collection Offset ^{#1}	Offset value for starting performance data collection (in seconds). For details about the offset value, see the chapter that describes management of operation monitoring data in the <i>JP1/Performance Management User's Guide</i> . For details about the start time for performance data collection, see the chapter that describes the functions of Performance Management in the <i>JP1/Performance Management Planning and Configuration Guide</i> .	N: Not changeable
Log	Whether collected performance data is stored in the Store database: Yes: Store (however, if <code>Collection Interval=0</code> is set, collected performance data is not stored). No: Do not store.	
LOGIF	Conditions for storing collected performance data in the Store database	
Over 10 Sec Collection Time ^{#2}	Whether the system configuration might require 10 sec or more to collect records. Yes: Might require 10 sec or more. No: Requires less than 10 sec.	
Realtime Report Data Collection Mode ^{#2}	Specifies the real-time report display mode: Reschedule: Reschedule mode Temporary Log: Temporary log mode Specify the temporary log mode (<code>Temporary Log</code>) for records for which Yes is set for <code>Over 10 Sec Collection Time</code> .	

#1

The value range is 0-32,767 seconds (within the value range specified for `Collection Interval`). This is used to distribute the collection processing workload, because data collection is concentrated when multiple data items are collected. The data collection time that is recorded is the same as for the `Collection Interval` regardless of the value of `Collection Offset`.

If you change the value of `Collection Offset`, you should take into account the collection processing workload.

#2

Displayed for the history collection priority function.

ODBC key fields

Shows the primary keys that are required in order to use the record data stored in the Store database with PFM - Manager or PFM - Base. Some ODBC key fields are common to all records, and some are specific to each record. This section presents the ODBC key fields that are specific to each record. Only the multi-instance records have specific ODBC key fields.

For details about the ODBC key fields common to all records, see *List of ODBC key fields*. For details about how to use the ODBC key fields, see the chapter that describes linkage to an ODBC-compatible application program in the *JPI/Performance Management User's Guide*.

Lifetime

Indicates the period during which consistency is guaranteed for the performance data that is collected in the record. For details about the lifetime, see the chapter that describes the functions of Performance Management in the *JPI/Performance Management Planning and Configuration Guide*.

Record size

Indicates the amount of performance data that can be collected and stored in each record at one time.

Fields

Provides a table that describes the fields of each record. The table contains the following items:

- PFM - View name (PFM - Manager name)
 - PFM - View name
Indicates the field name that is displayed by PFM - Web Console.
 - PFM - Manager name
Indicates the field name (PFM - Manager name) to be specified in SQL statements when the statements are used from PFM - Manager to access the field data stored in the Store database.
You specify the record ID at the beginning of an SQL statement. For example, to specify the DialogSteps (DIALOG_STEPS) field of the Dialog Service (PI_DIA) record, specify PI_DIA_DIALOG_STEPS.
- Description
Explanation of the performance data that is stored in the field.
- Summary
Method (summary rules) used by Agent Store to summarize data. For details about the summary rules, see *Summary rules* later.
- Format
Data type of the field value, such as `char` or `float`. For details about the data types, see *List of data types* later.
- Delta
In contrast to the data collected as the cumulative value, the so-called *delta* is the data that indicates the changed amount. For details about delta, see *Field values* later.
- Supported version
Indicates the SAP Basis version that can use the field. If a version number is shown, the field is supported by that version and all subsequent versions. A cell with three dashes (--) means that the field can be used regardless of the SAP Basis version.
- Data source
Method used to obtain the field value or the source of the data. For details about field values, see *Field values* later.

List of ODBC key fields

Some ODBC key fields are common to all records, and some are specific a record. This section presents the ODBC key fields common to all records. You need the ODBC key fields to use record data stored in the Store database with PFM - Manager.

The table below lists the ODBC key fields common to all records. For details about the ODBC key fields specific to each record, see the details of each record.

Table 10–1: List of ODBC key fields common to all records

ODBC key field	ODBC format	Delta	Description
<i>record-ID</i> _DATE	SQL_INTEGER	Internal	Key in the record that indicates the record creation date
<i>record-ID</i> _DATETIME	SQL_INTEGER	Internal	Combination of the <i>record-ID</i> _DATE and <i>record-ID</i> _TIME fields
<i>record-ID</i> _DEVICEID	SQL_VARCHAR	Internal	<i>instance-name</i> [<i>host-name</i>]
<i>record-ID</i> _DRAWER_TYPE	SQL_VARCHAR	Internal	Type. Valid values are as follows: m: Minute H: Hour D: Day W: Week M: Month Y: Year
<i>record-ID</i> _PROD_INST	SQL_VARCHAR	Internal	Instance name of PFM - Agent
<i>record-ID</i> _PRODID	SQL_VARCHAR	Internal	Product ID of PFM - Agent
<i>record-ID</i> _RECORD_TYPE	SQL_VARCHAR	Internal	Identifier indicating the record type (4 bytes)
<i>record-ID</i> _TIME	SQL_INTEGER	Internal	Record creation time (Greenwich mean time (GMT))

Summary rules

A summary record summarizes data collected at a specific interval (minute, hour, day, week, month, or year) and stores it in the Store database. The summarization is performed on the basis of the definition for operation specified for each field. Such definitions for operation are called the *summary rules*.

A field that is added to the Store database as a result of summarization is called an *added field*. Whether there is an added field and an added field's type depend on the summary rule. Some added fields are displayed as record fields in PFM - Web Console. Those added fields that are displayed in PFM - Web Console can be used as fields that are displayed in the historical reports.

To distinguish from the *added fields* that are added during summarization, the fields described in each record explanation are called *fixed fields*.

The name of an added field is as follows:

- Name of an added field that is stored in the Store database
PFM - Manager name of the fixed field with a suffix
- Name of an added field that is displayed in PFM - Web Console
PFM - View name of the fixed field with a suffix

The following table lists the suffixes used for the PFM - Manager names, the suffixes for the corresponding PFM - View names, and the data that is stored in the fields.

Table 10–2: List of suffixes for added fields

PFM - Manager name	PFM - View name	Stored data
<code>_TOTAL</code>	(Total)	Sum of the field's values in the records collected in the summary period
<code>_TOTAL_SEC</code>	(Total)	Sum of the field's values in the records collected in the summary period (applicable to the <code>utime</code> type)
<code>_COUNT</code>	--	Number of records collected in the summary period
<code>_HI</code>	(Max)	Maximum field value in the records collected in the summary period
<code>_LO</code>	(Min)	Minimum field value in the records collected in the summary period

Legend:

--: There is no added field.

The following lists and describes the summary rules.

Table 10–3: List of summary rules

Summary rule name	Summary rule
<code>COPY</code>	Stores the field value in the most recent record within the summary period.
<code>AVG</code>	Stores the average field value in the summary period. The formula is as follows: (sum of field's values)/(number of collected records) Added field (Store database) <ul style="list-style-type: none">• <code>_TOTAL</code>• <code>_TOTAL_SEC</code> (applicable to the <code>utime</code> type)• <code>_COUNT</code>

Summary rule name	Summary rule
AVG	Added field (PFM - Web Console) ^{#1, #2} <ul style="list-style-type: none"> • (Total)
ADD	Stores the sum of the field's values in the summary period.
HI	Stores the field's maximum value in the summary period.
LO	Stores the field's minimum value in the summary period.
HILO	Stores the maximum, minimum, and average values of data in the summary period. The average value is stored in a fixed-field. The formula is as follows: (sum of field's values)/(number of collected records) Added field (Store database) <ul style="list-style-type: none"> • <code>_HI</code> • <code>_LO</code> • <code>_TOTAL</code> • <code>_TOTAL_SEC</code> (applicable to the <code>utime</code> type) • <code>_COUNT</code> Added field (PFM - Web Console) ^{#1, #2} <ul style="list-style-type: none"> • (Max) • (Min) • (Total)
%	Stores the average field value in the summary period. This rule is mainly applied to a field for a percentage ratio. The formula is as follows: (sum of field's values)/(number of collected records) Added field (Store database) <ul style="list-style-type: none"> • <code>_TOTAL</code> • <code>_TOTAL_SEC</code> (applicable to the <code>utime</code> type) • <code>_COUNT</code> Added field (PFM - Web Console) ^{#3} <ul style="list-style-type: none"> • (Total)
R	Stores the average field value in the summary period. This rule is mainly applied to a field that indicates a quantity per second. The formula is as follows: (sum of field's values)/(number of collected records) When <code>delta</code> is specified for a <code>Real-Time</code> report, a special calculation that divides a difference by <code>Interval</code> is employed. Added field (Store database) <ul style="list-style-type: none"> • <code>_TOTAL</code> • <code>_COUNT</code> Added field (PFM - Web Console) ^{#1, #2} <ul style="list-style-type: none"> • (Total)
--	Not summarized.

#1

For a `utime` type field that contains `_AVG` in its PFM - Manager name, the (Total) field added in PFM - Web Console cannot be used in historical reports.

#2

For a field that contains any of the following character strings in its PFM - Manager name, the (Total) field added in PFM - Web Console cannot be used in historical reports:

`_PER_`, `PCT`, `PERCENT`, `_AVG`, `RATE_TOTAL`

#3

In the case of a `utime` type field only, the (Total) field added in PFM - Web Console can be used in historical reports.

List of data types

The table below lists the data types for field values, and their corresponding C and C++ data types. The values shown in the *Format* column of the record field tables are those shown below in the *Field* column under *Data type*.

Table 10–4: List of data types

Data type		Size(bytes)	Description
Field	C and C++		
char (<i>n</i>)	char ()	Value in parentheses	Character data with a length of <i>n</i> bytes
double	double	8	Numeric value (1.7E±308 (15 digits))
float	float	4	Numeric value (3.4E±38 (7 digits))
long	long	4	Numeric value (-2,147,483,648 to 2,147,483,647)
short	short	2	Numeric value (-32,768 to 32,767)
string (<i>n</i>)	char[]	Value in parentheses	Character string with a length of <i>n</i> bytes. The last character is null.
time_t	unsigned long	4	Numeric value (0 to 4,294,967,295)
timeval	Structure	8	Numeric value (first 4 bytes are seconds, next 4 bytes are microseconds)
ulong	unsigned long	4	Numeric value (0 to 4,294,967,295)
utime	Structure	8	Numeric value (first 4 bytes are seconds, next 4 bytes are microseconds)
word	unsigned short	2	Numeric value (0 to 65,535)
(Not applicable)	unsigned char	1	Numeric value (0 to 255)

Field values

This section describes the values stored in the fields.

Data source

Each field contains a value obtained from a Performance Management product or monitored program or a value derived by applying a formula. In the tables, the *Data source* column indicates the source of the value or the formula used to produce the value.

The character string in the *Data source* column for PFM - Agent for Enterprise Applications indicates the transaction code of the SAP system. It means that the value indicated by the corresponding transaction code is to be obtained. If the value cannot be identified by the transaction code alone, the monitoring tree element (MTE) name is also provided (for example, *SAP-system-ID\SAP-instance-name\Background\Utilisation*). For details about the MTE name, see the documentation for your SAP system.

Delta

In contrast to the data collected as the cumulative value, the so-called *delta* is the data that indicates the changed amount. For example, if the performance data value obtained during the first collection is 3 and the performance data value obtained during the second collection is 4, then the cumulative value is 7 and the changed amount is 1. In the tables, the *Delta* column indicates whether each field's value is a delta value.

The following table explains the delta characteristics of performance data collected by PFM - Agent for Enterprise Applications:

Record type	Delta	Data type	Indicate delta value [#]	Record value
PI record type	Yes	Real-time data	Selected	The displayed value is the changed amount.
			Not selected	The displayed value is the cumulative value.
		<ul style="list-style-type: none"> Historical data Alarm monitoring data 	N/A	The displayed value is the changed amount.
	No	Real-time data	Selected	The displayed value was the actual value at the time of data collection.
			Not selected	The displayed value was the actual value at the time of data collection.
		<ul style="list-style-type: none"> Historical data Alarm monitoring data 	N/A	The displayed value was the actual value at the time of data collection.
PD record type	Yes	Real-time data	Selected	The displayed value is the change.
			Not selected	The displayed value is the cumulative value.
		<ul style="list-style-type: none"> Historical data Alarm monitoring data 	N/A	The displayed value is the cumulative value.
	No	Real-time data	Selected	The displayed value was the actual value at the time of data collection.

Record type	Delta	Data type	Indicate delta value [#]	Record value
PD record type	No	Real-time data	Not selected	The displayed value was the actual value at the time of data collection.
		<ul style="list-style-type: none"> • Historical data • Alarm monitoring data 	N/A	The displayed value was the actual value at the time of data collection.

Legend:

N/A: Not applicable

#

The following setting is specified in PFM - Web Console:

- **Indicate delta value** is selected in the report wizard's **Edit > Indication settings (Realtime)** window.
- **Indicate delta value** is selected in **Indication settings (Realtime)** on the **Properties** page in the report window.

The following point should be noted about collection of performance data:

- If you select the **Indicate delta value** option for a real-time report, the value that is displayed is since the time the first data was collected. If the report requires previous data, the initial value is 0. The value of the collected data is displayed after the second data collection.

Fields added only when data is stored in the Store database

The following table lists the fields that are added only when data is stored in the Store database:

PFM - View name (PFM - Manager name)	Description	Frmt	Delta	Sup. ver.	Data source
Agent Host (DEVICEID)	Name of host where PFM - Agent is running	string (256)	No	All	--
Agent Instance (PROD_INST)	Instance name of PFM - Agent	string (256)	No	All	--
Agent Type (PRODID)	Product ID of PFM - Agent (1-byte identifier)	char	No	All	--
Date (DATE)	Record creation date (GMT) ^{#1, #2}	char (3)	No	All	--
Date and Time (DATETIME)	Combination of the Date (DATE) and Time (TIME) fields ^{#2}	char (6)	No	All	--
Drawer Type (DRAWER_TYPE)	Data summarization type (for a record of the PI record type).	char	No	All	--
GMT Offset (GMT_ADJUST)	Difference (in seconds) between Greenwich Mean Time and local time	long	No	All	--
Time (TIME)	Record creation time (GMT) ^{#1, #2}	char (3)	No	All	--

Legend:

Smry: Summary

Frmt: Format

Sup. ver.: Supported version

--: Indicates that the field's value is obtained without processing the performance data acquired from SAP system.

#1

The referencing time during summarization is set because data is summarized for records of the PI record type. The following table shows the setting value for each record type:

Type	Setting value for each record type
Minute	0 second of the time when the record was created.
Hour	0 minute and 0 second of the time when the record was created.
Day	0:00 and 0 second of the day when the record was created.
Week	0:00 and 0 second on Monday of the week when the record was created.
Month	0:00 and 0 second on the 1st day of the month when the record was created.
Year	0:00 and 0 second on January 1st of the year when the record was created.

#2

When data is displayed in a report, a Date field is displayed in the format *YYYYMMDD*, a Date and Time field is displayed in the format *YYYYMMDD hh:mm:ss*, and a Time field is displayed in the format *hh:mm:ss*.

Notes about records

This subsection provides notes about collecting records.

Record creation result when data cannot be acquired

The following describes the record creation result when data to be stored in fields cannot be acquired.

- No record is created.

No record is created in the following cases:

- PFM - Agent for Enterprise Applications cannot collect the performance data that is to be stored in the field defined as the ODBC key field.
 - PFM - Agent for Enterprise Applications cannot collect the performance data that is to be stored in the field indicating Enterprise Applications' performance value.
 - PFM - Agent for Enterprise Applications cannot collect the performance data of an SAP system.
- A record with null fields is created.

A record with null fields is created in the following cases:

- PFM - Agent for Enterprise Applications failed the collection of character-type data.
 - PFM - Agent for Enterprise Applications collected null character-type data.
- A record containing a field with the value -1 is created.

If PFM - Agent for Enterprise Applications fails the collection of numeric-type component data, a record containing a field with the value -1 is created.

- A record containing a field with the value Unknown is created.

A record containing a field with the value Unknown is created in the following cases:

- Field has a definition area in the data model, but the data collected by PFM - Agent for Enterprise Applications is not included in that definition area.
- PFM - Agent for Enterprise Applications cannot collect data for a field that has a definition area in the data model.

Notes about records of the PI record type

The following describes notes about records of the PI record type.

- Performance data that is collected

PFM - Agent for Enterprise Applications collects the average values of the last minute of performance data in all the performance data reported periodically in the SAP system and then stores that value in the record.

- Record creation results if the performance data remains the same in the SAP system

PFM - Agent for Enterprise Applications collects the most recent performance data reported in the SAP system and then stores that data in the record.

For example, if the performance data remains the same in the SAP system as shown below, PFM - Agent for Enterprise Applications stores the last performance data reported in the SAP system in the record.

Table 10–5: Performance data update status in the SAP system

Time	Performance data update status
10:00	Updated (performance data = 10.0)
10:01	Not updated
10:02	Not updated

Time	Performance data update status
10:03	Not updated
10:04	Not updated
10:05	Not updated

In this situation, if PFM - Agent for Enterprise Applications collects records at 10:05, the record that are created will be 10.0.

List of records

This section lists the records that can be collected by PFM - Agent for Enterprise Applications.

The following tables list the records that can be collected by PFM - Agent for Enterprise Applications and the information that is stored in each record, in the order of record names and record IDs.

Table 10–6: List of records for PFM - Agent for Enterprise Applications (record name)

Record name	Record ID	Information stored in record
Background Processing	PI_BTCP	Information about the status and processing efficiency of the background system in the entire SAP system
Background Service	PI_BTC	Statistical information about the background service
CCMS Alert Monitor Command	PD_ALMX	Result of extracting the CCMS alert information of the SAP system
Dialog Service	PI_DIA	Statistical information about the dialog service
Enqueue Service	PI_ENQ	Statistical information about the enqueueing service
SAP Buffer Summary	PI_BUFF	Summary information about the SAP buffers
SAP Instance Summary	PD_SRV	Information about SAP instances (equivalent to the information that can be verified by transaction code SM51)
SAP Memory Summary	PI_MEM	Summary information about various SAP memories
Spool Service	PI_SPO	Statistical information about the spool service
System Log Monitor Command	PD_SLMX	Result of extracting the system log information of the SAP system
Update1 Service	PI_UPD1	Statistical information about the V1 update service
Update2 Service	PI_UPD2	Statistical information about the V2 update service
User defined Monitor (Perf.)	PI_UMP	In SAP system monitor information, the performance information collected according to user definitions
Work Process Summary	PD	Overview of work processes (equivalent to the information that can be verified by transaction code SM50)
WorkLoad Summary Interval	PI	Information needed to obtain and analyze the dialog task's workload time statistics

Table 10–7: List of records for PFM - Agent for Enterprise Applications (record ID)

Record ID	Record name	Information stored in record
PD	Work Process Summary	Overview of work processes (equivalent to the information that can be verified by transaction code SM50)
PD_ALMX	CCMS Alert Monitor Command	Result of extracting the CCMS alert information of the SAP system
PD_SLMX	System Log Monitor Command	Result of extracting the system log information of the SAP system
PD_SRV	SAP Instance Summary	Information about SAP instances (equivalent to the information that can be verified by transaction code SM51)
PI	WorkLoad Summary Interval	Information needed to obtain and analyze the dialog task's workload time statistics

Record ID	Record name	Information stored in record
PI_BTC	Background Service	Statistical information about the background service
PI_BTCP	Background Processing	Information about the status and processing efficiency of the background system in the entire SAP system
PI_BUFF	SAP Buffer Summary	Summary information about the SAP buffers
PI_DIA	Dialog Service	Statistical information about the dialog service
PI_ENQ	Enqueue Service	Statistical information about the enqueueing service
PI_MEM	SAP Memory Summary	Summary information about various SAP memories
PI_SPO	Spool Service	Statistical information about the spool service
PI_UMP	User defined Monitor (Perf.)	In SAP system monitor information, the performance information collected according to user definitions
PI_UPD1	Update1 Service	Statistical information about the V1 update service
PI_UPD2	Update2 Service	Statistical information about the V2 update service

Background Processing (PI_BTCP)

Function

The Background Processing (PI_BTCP) record stores information about the status and processing efficiency of the background system of the entire SAP system.

Default and changeable values

Item	Default value	Changeable
Collection Interval	600	Y
Collection Offset	40	Y
Log	No	Y
LOGIF	(Blank)	Y
Over 10 Sec Collection Time	No	N
Realtime Report Data Collection Mode	Reschedule	Y

ODBC key fields

None

Lifetime

None

Record size

- Fixed part: 743 bytes
- Variable part: 0 bytes

Fields

PFM - View name (PFM - Manager name)	Description	Smry	Frmt	Delta	Sup. ver.	Data source
Instance Name (INSTANCE_NAME)	SAP instance name. This name usually consists of a host name, SAP system ID, and system number. This setting can be changed by the rdisp/myname parameter.	COPY	string(21)	No	7.00 or later	--
Interval (INTERVAL)	Interval in seconds at which records were stored (current value in Record Time field - previous value in Record Time field). The initial value is 0.	ADD	ulong	No	7.00 or later	--
Record Time (RECORD_TIME)	Record creation time	COPY	time_t	No	7.00 or later	--
Record Type (INPUT_RECORD_TYPE)	Record type (BTCP)	COPY	char(8)	No	7.00 or later	--

PFM - View name (PFM - Manager name)	Description	Smry	Frmt	Delta	Sup. ver.	Data source
System ID (SYSTEM_ID)	SAP system ID	COPY	string(9)	No	7.00 or later	--
SystemWideFreeBPWP (SYSTEM_WIDE_FREE_BP_WP)	Number of free background work processes in the entire system.	AVG	float	No	7.00 or later	RZ20 (SAP-system-ID \BackgroundService \SystemWideFreeBPWP)
SystemWideQueueLength (SYSTEM_WIDE_QUEUE_LENGTH)	Average number of jobs waiting for background work processes at all application servers	AVG	float	No	7.00 or later	RZ20 (SAP-system-ID \BackgroundService \SystemWideQueueLength)

Legend:

Smry: Summary

Frmt: Format

Sup. ver.: Supported version

Background Service (PI_BTC)

Function

The Background Service (PI_BTC) record stores statistical information about the background service. One record is created for each SAP instance that provides this service.

Default and changeable values

Item	Default value	Changeable
Collection Interval	600	Y
Collection Offset	40	Y
Log	No	Y
LOGIF	(Blank)	Y
Over 10 Sec Collection Time	No	N
Realtime Report Data Collection Mode	Reschedule	Y

ODBC key fields

None

Lifetime

None

Record size

- Fixed part: 759 bytes
- Variable part: 0 bytes

Fields

PFM - View name (PFM - Manager name)	Description	Smry	Frmt	Delta	Sup. ver.	Data source
Instance Name (INSTANCE_NAME)	SAP instance name. This name usually consists of a host name, SAP system ID, and system number. This setting can be changed by the rdisp/myname parameter.	COPY	string(21)	No	7.00 or later	--
Interval (INTERVAL)	Interval in seconds at which records were stored (current value in Record Time field - previous value in Record Time field). The initial value is 0.	ADD	ulong	No	7.00 or later	--
NumberOfWpBTC (NUMBER_OF_WP_BTC)	Number of background work processes on a single application server	AVG	float	No	7.00 or later	RZ20 (SAP-system-ID \SAP-instance-name \Background \NumberOfWpBTC)
Record Time	Record creation time	COPY	time_t	No	7.00 or later	--

PFM - View name (PFM - Manager name)	Description	Smry	Frmt	Delta	Sup. ver.	Data source
(RECORD_TIME)	Record creation time	COPY	time_t	No	7.00 or later	--
Record Type (INPUT_RECORD_TYPE)	Record type (BTC)	COPY	char (8)	No	7.00 or later	--
ServerSpecificQueueLength (SERVER_SPECIFIC_QUEUE_LENGTH)	Number of jobs that must be executed explicitly at the application server but are waiting for an available background work process	AVG	float	No	7.00 or later	RZ20 (SAP-system-ID \SAP-instance-name \Background \ServerSpecificQueueLength)
System ID (SYSTEM_ID)	SAP system ID	COPY	string (9)	No	7.00 or later	--
Utilization % (UTILIZATION)	Current usage of background processing capacity. This field contains the average of the percentage values for all background work processes.	%	float	No	7.00 or later	RZ20 (SAP-system-ID \SAP-instance-name \Background \Utilisation)

Legend:

Smry: Summary

Frmt: Format

Sup. ver.: Supported version

CCMS Alert Monitor Command (PD_ALMX)

Function

The CCMS Alert Monitor Command (PD_ALMX) record stores the result of extracting the CCMS alert information of the SAP system.

Note

- This record cannot be displayed in real-time reports.

Default and changeable values

Item	Default value	Changeable
Collection Interval	600	Y
Collection Offset	0	Y
Log	No	Y
LOGIF	(Blank)	Y
Over 10 Sec Collection Time	No	N
Realtime Report Data Collection Mode	Reschedule	Y

ODBC key fields

None

Lifetime

None

Record size

- Fixed part: 5,073 bytes
- Variable part: 0 bytes

Fields

PFM - View name (PFM - Manager name)	Description	Frmt	Delta	Sup. ver.	Data source
Elapsed Time (ELAPSED_TIME)	Command execution time in milliseconds	ulong	No	7.00 or later	--
Exit Code (EXIT_CODE)	Command termination code	ulong	No	7.00 or later	--
Instance Name (INSTANCE_NAME)	SAP instance name. This name usually consists of a host name, SAP system ID, and system number. This setting can be changed by the <code>rdisp/myname</code> parameter.	string(21)	No	--	--
Interval (INTERVAL)	Interval in seconds at which records were stored (current value in Record	ulong	No	--	--

PFM - View name (PFM - Manager name)	Description	Frmt	Delta	Sup. ver.	Data source
Interval (INTERVAL)	Time field - previous value in Record Time field). The initial value is 0.	ulong	No	--	--
Path (PATH)	Command path (excluding the argument part)	string(256)	No	7.00 or later	--
Record Time (RECORD_TIME)	Record creation time	time_t	No	--	--
Record Type (INPUT_RECORD_TYPE)	Record type (ALMX)	char(8)	No	--	--
Stderr Buffer (STDERR_BUFFER)	Standard error output buffer for the command	string(2049)	No	7.00 or later	--
Stdout Buffer (STDOUT_BUFFER)	Standard output buffer for the command	string(2049)	No	7.00 or later	--
System ID (SYSTEM_ID)	SAP system ID	string(9)	No	--	--

Legend:

Smry: Summary

Frmt: Format

Sup. ver.: Supported version

Dialog Service (PI_DIA)

Function

The Dialog Service (PI_DIA) record stores statistical information about the dialog service. One record is created for each SAP instance that provides this service.

Default and changeable values

Item	Default value	Changeable
Collection Interval	600	Y
Collection Offset	35	Y
Log	No	Y
LOGIF	(Blank)	Y
Over 10 Sec Collection Time	No	N
Realtime Report Data Collection Mode	Reschedule	Y

ODBC key fields

None

Lifetime

None

Record size

- Fixed part: 959 bytes
- Variable part: 0 bytes

Fields

PFM - View name (PFM - Manager name)	Description	Smry	Frmt	Delta	Sup. ver.	Data source
DBRequestTime (DB_REQUEST_TIME)	Average time for processing logical database requests in milliseconds	AVG	float	No	7.00 or later	RZ20 (SAP-system-ID \SAP-instance-name \Dialog \DBRequestTime)
DialogSteps (DIALOG_STEPS)	Average number of dialog steps per minute	AVG	float	No	7.00 or later	RZ20 (SAP-system-ID \SAP-instance-name \Dialog \DialogSteps)
FrontendNetTime (FRONTEND_NET_TIME)	Network time (in milliseconds) used for the first data transfer from front end to application server and for the last data transfer from application server to front end. This does not include the value of the GuiCallBackTime field.	AVG	float	No	7.00 or later	RZ20 (SAP-system-ID \SAP-instance-name \Dialog \FrontEndNetTime)

PFM - View name (PFM - Manager name)	Description	Smry	Frmt	Delta	Sup. ver.	Data source
FrontendResponseTime (FRONTEND_RESPONSE_TIME)	Average time (in milliseconds) the user waited at the front end for a request to be processed. This is the average of the totals of response time, network transfer time, and front-end processing time.	AVG	float	No	7.00 or later	RZ20 (SAP-system-ID \SAP-instance-name \Dialog \FrontendResponseTime)
GuiCallBackTime (GUI_CALL_BACK_TIME)	Average time (in milliseconds) the work process waited for the front end during communications between the application server and the front end in dialog steps.	AVG	float	No	7.00 or later	RZ20 (SAP-system-ID \SAP-instance-name \Dialog \GuiCallBackTime)
Instance Name (INSTANCE_NAME)	SAP instance name. This name usually consists of a host name, SAP system ID, and system number. This setting can be changed by the rdisp/myname parameter.	COPY	string(21)	No	7.00 or later	--
Interval (INTERVAL)	Interval in seconds at which records were stored (current value in Record Time field - previous value in Record Time field). The initial value is 0.	ADD	ulong	No	7.00 or later	--
Load+GenTime (LOAD_GENTIME)	Average loading and creation time (in milliseconds) for source text, graphical user interface, and window information from the database	AVG	float	No	7.00 or later	RZ20 (SAP-system-ID \SAP-instance-name \Dialog\Load+GenTime)
LongRunners (LONG_RUNNERS)	Number of dialog work processes that have been running for a long time	AVG	float	No	7.00 or later	RZ20 (SAP-system-ID \SAP-instance-name \Dialog \LongRunners)
MonitoringTime (MONITORING_TIME)	Average time (in milliseconds) required for creating monitoring data in dialog steps	AVG	float	No	7.00 or later	RZ20 (SAP-system-ID \SAP-instance-name \Dialog \MonitoringTime)
NumberOfWPDia (NUMBER_OF_WP_DIA)	Number of dialog work processes	AVG	float	No	7.00 or later	RZ20 (SAP-system-ID \SAP-instance-name \Dialog \NumberOfWpDIA)
QueueLength % (QUEUE_LENGTH)	Average usage of the dispatcher queue	%	float	No	7.00 or later	RZ20 (SAP-system-ID \SAP-instance-name \Dialog \QueueLength)
QueueTime (QUEUE_TIME)	Average wait time (in milliseconds) in the dispatcher queue for user requests	AVG	float	No	7.00 or later	RZ20 (SAP-system-ID \SAP-instance-name \Dialog \QueueTime)
Record Time (RECORD_TIME)	Record creation time	COPY	time_t	No	7.00 or later	--
Record Type (INPUT_RECORD_TYPE)	Record type (DIA)	COPY	char(8)	No	7.00 or later	--

PFM - View name (PFM - Manager name)	Description	Smry	Frmt	Delta	Sup. ver.	Data source
ResponseTime (RESPONSE_TIME)	Average dialog step processing time in milliseconds. This is the total time required for processing a dialog step; it includes the database processing time but not the network transfer time or front-end processing time. If there is no dialog step, the average processing time of the last period in which a dialog step existed is reported.#	AVG	float	No	7.00 or later	RZ20 (SAP-system-ID \SAP-instance-name \Dialog \ResponseTime)
ResponseTime:StandardTran. (RESPONSE_TIME_STANDARD_TRAN)	Response time of standard transactions in milliseconds	AVG	float	No	7.00 or later	RZ20 (SAP-system-ID \SAP-instance-name \Dialog \ResponseTime(StandardTran))
System ID (SYSTEM_ID)	SAP system ID	COPY	string(9)	No	7.00 or later	--
UsersLoggedIn (USERS_LOGGED_IN)	Number of users logged on	HILO	float	No	7.00 or later	RZ20 (SAP-system-ID \SAP-instance-name \Dialog \UsersLoggedIn)
Utilization % (UTILIZATION)	Average usage of dialog work processes per application server	%	float	No	7.00 or later	RZ20 (SAP-system-ID \SAP-instance-name \Dialog \Utilisation)

Legend:

Smry: Summary

Frmt: Format

Sup. ver.: Supported version

#

The average dialog step processing time is not updated in the SAP system during any period in which no dialog step exists. In this case, the average processing time of the last dialog step updated in the SAP system (the average processing time of the last period in which a dialog step existed) is reported. For details about this processing, see *Notes about records of the PI record type* in *Notes about records* in *Chapter 10. Records*.

Enqueue Service (PI_ENQ)

Function

The Enqueue Service (PI_ENQ) record stores statistical information about the enqueueing service. One record is created for each SAP instance.

Default and changeable values

Item	Default value	Changeable
Collection Interval	600	Y
Collection Offset	40	Y
Log	No	Y
LOGIF	(Blank)	Y
Over 10 Sec Collection Time	No	N
Realtime Report Data Collection Mode	Reschedule	Y

ODBC key fields

None

Lifetime

None

Record size

- Fixed part: 743 bytes
- Variable part: 0 bytes

Fields

PFM - View name (PFM - Manager name)	Description	Smry	Frmt	Delta	Sup. ver.	Data source
EnqueueClient EnqueueFreq (ENQUEUE_CLIENT_ENQUEUE_FREQ)	Number of enqueue processes per minute from another instance to the central instance (logical data lock)	AVG	float	No	7.00 or later	RZ20 (SAP-system-ID \SAP-instance-name \Enqueue Client \EnqueueFreq)
EnqueueServer QueueLength % (ENQUEUE_SERVER_QUEUE_LENGTH)	Percentage of the enqueue service's queue length. If the SAP system has an ASCS instance configuration, the value of this field is zero because this field does not exist in the connected dialog instance.	%	float	No	7.00 or later	RZ20 (SAP-system-ID \SAP-instance-name \Enqueue Server \QueueLength)
Instance Name (INSTANCE_NAME)	SAP instance name. This name usually consists of a host name, SAP system ID, and system number. This setting can be changed by the rdisp/myname parameter.	COPY	string (21)	No	7.00 or later	--

PFM - View name (PFM - Manager name)	Description	Smry	Frmt	Delta	Sup. ver.	Data source
Interval (INTERVAL)	Interval in seconds at which records were stored (current value in Record Time field - previous value in Record Time field). The initial value is 0.	ADD	ulong	No	7.00 or later	--
Record Time (RECORD_TIME)	Record creation time	COPY	time_t	No	7.00 or later	--
Record Type (INPUT_RECORD_TYPE)	Record type (ENQ)	COPY	char(8)	No	7.00 or later	--
System ID (SYSTEM_ID)	SAP system ID	COPY	string(9)	No	7.00 or later	--

Legend:

Smry: Summary

Frmt: Format

Sup. ver.: Supported version

SAP Buffer Summary (PI_BUFF)

Function

The SAP Buffer Summary (PI_BUFF) record stores summary information about the SAP buffers. One record is created for each SAP instance.

- Nametab buffer (NTAB buffer)
 - Field description buffer (FTAB buffer, table DDNTF)
This buffer stores the description of repository items.
 - Initial record buffer (IREC buffer)
This buffer stores the layout of data records in a table.
 - Short nametab buffer (short NTAB buffer, SNTAB buffer)
This buffer combines the field description and table definition buffers and stores only the most important information in each buffer.
 - Table definition buffer (TTAB buffer, table DDNTT)
This buffer stores repository table definitions.
- Program buffer (R/3 executable buffer, ABAP buffer, PXA buffer)
This buffer stores compiled programs.
- R/3 GUI buffer
 - CUA buffer (Menu buffer)
This buffer stores the window menu and button definitions of the ABAP program.
 - Screen buffer (presentation buffer, Dynpro buffer)
This buffer stores the window information of the ABAP program.
- Table buffer
 - Generic key buffer (generic table buffer, TABL)
This buffer stores part or all of the database table contents.
 - Single record buffer (partial table buffer, TABLP)
This buffer stores individual records from the database table.

Default and changeable values

Item	Default value	Changeable
Collection Interval	600	Y
Collection Offset	40	Y
Log	No	Y
LOGIF	(Blank)	Y
Over 10 Sec Collection Time	No	N
Realtime Report Data Collection Mode	Reschedule	Y

ODBC key fields

None

Lifetime

None

Record size

- Fixed part: 1,287 bytes
- Variable part: 0 bytes

Fields

PFM - View name (PFM - Manager name)	Description	Smry	Frmt	Delta	Sup. ver.	Data source
CUA DirectoryUsed % (CUA_DIRECTORY_USED)	Usage of the CUA buffer directory (number of entries)	%	float	No	7.00 or later	RZ20 (SAP-system-ID \SAP-instance-name \CUA \DirectoryUsed)
CUA HitRatio % (CUA_HIT_RATIO)	Percentage of the database queries that were not passed to the database because they were found in the CUA buffer	%	float	No	7.00 or later	RZ20 (SAP-system-ID \SAP-instance-name \CUA\HitRatio)
CUA SpaceUsed % (CUA_SPACE_USED)	Usage of the CUA buffer storage	%	float	No	7.00 or later	RZ20 (SAP-system-ID \SAP-instance-name \CUA\SpaceUsed)
CUA Swap (CUA_SWAP)	Number of times swapping occurred in the CUA buffer per minute because the buffer was full	AVG	float	No	7.00 or later	RZ20 (SAP-system-ID \SAP-instance-name \CUA\Swap)
FieldDescription DirectoryUsed % (FIELD_DESCRIPTION_DIRECTORY_USED)	Usage of the field description buffer directory (number of entries)	%	float	No	7.00 or later	RZ20 (SAP-system-ID \SAP-instance-name \FieldDescription \DirectoryUsed)
FieldDescription HitRatio % (FIELD_DESCRIPTION_HIT_RATIO)	Percentage of the database queries that were not passed to the database because they were found in the field description buffer	%	float	No	7.00 or later	RZ20 (SAP-system-ID \SAP-instance-name \FieldDescription \HitRatio)
FieldDescription SpaceUsed % (FIELD_DESCRIPTION_SPACE_USED)	Usage of the field description buffer storage	%	float	No	7.00 or later	RZ20 (SAP-system-ID \SAP-instance-name \FieldDescription \SpaceUsed)
FieldDescription Swap (FIELD_DESCRIPTION_SWAP)	Number of times swapping occurred in the field description buffer per minute because the buffer was full	AVG	float	No	7.00 or later	RZ20 (SAP-system-ID \SAP-instance-name \FieldDescription \Swap)
GenericKey DirectoryUsed % (GENERIC_KEY_DIRECTORY_USED)	Usage of the generic key buffer directory (number of entries)	%	float	No	7.00 or later	RZ20 (SAP-system-ID \SAP-instance-name \GenericKey \DirectoryUsed)
GenericKey HitRatio % (GENERIC_KEY_HIT_RATIO)	Percentage of the database queries that were not passed to the database because they were found in the generic key buffer	%	float	No	7.00 or later	RZ20 (SAP-system-ID \SAP-instance-name \GenericKey \HitRatio)

PFM - View name (PFM - Manager name)	Description	Smry	Frmt	Delta	Sup. ver.	Data source
GenericKey SpaceUsed % (GENERIC_KEY_SPACE_USED)	Usage of the generic key buffer storage	%	float	No	7.00 or later	RZ20 (SAP-system-ID \SAP-instance-name \GenericKey \SpaceUsed)
GenericKey Swap (GENERIC_KEY_SWAP)	Number of times swapping occurred in the generic key buffer per minute because the buffer was full	AVG	float	No	7.00 or later	RZ20 (SAP-system-ID \SAP-instance-name \GenericKey\Swap)
InitialRecords DirectoryUsed % (INITIAL_RECORDS_DIRECTORY_USED)	Usage of the initial records buffer directory (number of entries)	%	float	No	7.00 or later	RZ20 (SAP-system-ID \SAP-instance-name \InitialRecords \DirectoryUsed)
InitialRecords HitRatio % (INITIAL_RECORDS_HIT_RATIO)	Percentage of the database queries that were not passed to the database because they were found in the initial records buffer	%	float	No	7.00 or later	RZ20 (SAP-system-ID \SAP-instance-name \InitialRecords \HitRatio)
InitialRecords SpaceUsed % (INITIAL_RECORDS_SPACE_USED)	Usage of the initial records buffer storage	%	float	No	7.00 or later	RZ20 (SAP-system-ID \SAP-instance-name \InitialRecords \SpaceUsed)
InitialRecords Swap (INITIAL_RECORDS_SWAP)	Number of times swapping occurred in the initial records buffer per minute because the buffer was full	AVG	float	No	7.00 or later	RZ20 (SAP-system-ID \SAP-instance-name \InitialRecords \Swap)
Instance Name (INSTANCE_NAME)	SAP instance name. This name usually consists of a host name, SAP system ID, and system number. This setting can be changed by the rdisp/myname parameter.	COPY	string(21)	No	7.00 or later	--
Interval (INTERVAL)	Interval in seconds at which records were stored (current value in Record Time field - previous value in Record Time field). The initial value is 0.	ADD	ulong	No	7.00 or later	--
Program DirectoryUsed % (PROGRAM_DIRECTORY_USED)	Usage of the program buffer directory (number of entries)	%	float	No	7.00 or later	RZ20 (SAP-system-ID \SAP-instance-name \Program \DirectoryUsed)
Program HitRatio % (PROGRAM_HIT_RATIO)	Percentage of the database queries that were not passed to the database because they were found in the program buffer	%	float	No	7.00 or later	RZ20 (SAP-system-ID \SAP-instance-name \Program \HitRatio)
Program SpaceUsed % (PROGRAM_SPACE_USED)	Usage of the program buffer storage	%	float	No	7.00 or later	RZ20 (SAP-system-ID \SAP-instance-name \Program \SpaceUsed)
Program Swap (PROGRAM_SWAP)	Number of times swapping occurred in the program buffer per minute because the buffer was full	AVG	float	No	7.00 or later	RZ20 (SAP-system-ID \SAP-instance-name \Program\Swap)
Record Time	Record creation time	COPY	time_t	No	7.00 or later	--

PFM - View name (PFM - Manager name)	Description	Smry	Frmt	Delta	Sup. ver.	Data source
(RECORD_TIME)	Record creation time	COPY	time_t	No	7.00 or later	--
Record Type (INPUT_RECORD_TYPE)	Record type (BUFF)	COPY	char (8)	No	7.00 or later	--
Screen DirectoryUsed % (SCREEN_DIRECTORY_USED)	Usage of the screen buffer directory (number of entries)	%	float	No	7.00 or later	RZ20 (SAP-system-ID \SAP-instance-name \Screen \DirectoryUsed)
Screen HitRatio % (SCREEN_HIT_RATIO)	Percentage of the database queries that were not passed to the database because they were found in the screen buffer	%	float	No	7.00 or later	RZ20 (SAP-system-ID \SAP-instance-name \Screen \HitRatio)
Screen SpaceUsed % (SCREEN_SPACE_USED)	Usage of the screen buffer storage	%	float	No	7.00 or later	RZ20 (SAP-system-ID \SAP-instance-name \Screen \SpaceUsed)
Screen Swap (SCREEN_SWAP)	Number of times swapping occurred in the screen buffer per minute because the buffer was full	AVG	float	No	7.00 or later	RZ20 (SAP-system-ID \SAP-instance-name \Screen \Swap)
ShortNameTAB DirectoryUsed % (SHORT_NAME_TAB_DIRECTORY_USED)	Usage of the short nametab buffer directory (number of entries)	%	float	No	7.00 or later	RZ20 (SAP-system-ID \SAP-instance-name \ShortNameTAB \DirectoryUsed)
ShortNameTAB HitRatio % (SHORT_NAME_TAB_HIT_RATIO)	Percentage of the database queries that were not passed to the database because they were found in the short nametab buffer	%	float	No	7.00 or later	RZ20 (SAP-system-ID \SAP-instance-name \ShortNameTAB \HitRatio)
ShortNameTAB SpaceUsed % (SHORT_NAME_TAB_SPACE_USED)	Usage of the short nametab buffer storage	%	float	No	7.00 or later	RZ20 (SAP-system-ID \SAP-instance-name \ShortNameTAB \SpaceUsed)
ShortNameTAB Swap (SHORT_NAME_TAB_SWAP)	Number of times swapping occurred in the short nametab buffer per minute because the buffer was full	AVG	float	No	7.00 or later	RZ20 (SAP-system-ID \SAP-instance-name \ShortNameTAB \Swap)
SingleRecord DirectoryUsed % (SINGLE_RECORD_DIRECTORY_USED)	Usage of the single record buffer directory (number of entries)	%	float	No	7.00 or later	RZ20 (SAP-system-ID \SAP-instance-name \SingleRecord \DirectoryUsed)
SingleRecord HitRatio % (SINGLE_RECORD_HIT_RATIO)	Percentage of the database queries that were not passed to the database because they were found in the single record buffer	%	float	No	7.00 or later	RZ20 (SAP-system-ID \SAP-instance-name \SingleRecord \HitRatio)
SingleRecord SpaceUsed % (SINGLE_RECORD_SPACE_USED)	Usage of the single record buffer storage	%	float	No	7.00 or later	RZ20 (SAP-system-ID \SAP-instance-name \SingleRecord \SpaceUsed)

PFM - View name (PFM - Manager name)	Description	Smry	Frmt	Delta	Sup. ver.	Data source
SingleRecord Swap (SINGLE_RECORD_SWAP)	Number of times swapping occurred in the single record buffer per minute because the buffer was full	AVG	float	No	7.00 or later	RZ20 (SAP-system-ID \SAP-instance-name \SingleRecord \Swap)
System ID (SYSTEM_ID)	SAP system ID	COPY	string(9)	No	7.00 or later	--
TableDefinition DirectoryUsed % (TABLE_DEFINITION_DIRECTORY_USED)	Usage of the table definition buffer directory (number of entries)	%	float	No	7.00 or later	RZ20 (SAP-system-ID \SAP-instance-name \TableDefinition \DirectoryUsed)
TableDefinition HitRatio % (TABLE_DEFINITION_HIT_RATIO)	Percentage of the database queries that were not passed to the database because they were found in the table definition buffer	%	float	No	7.00 or later	RZ20 (SAP-system-ID \SAP-instance-name \TableDefinition \HitRatio)
TableDefinition SpaceUsed % (TABLE_DEFINITION_SPACE_USED)	Usage of the table definition buffer storage	%	float	No	7.00 or later	RZ20 (SAP-system-ID \SAP-instance-name \TableDefinition \SpaceUsed)
TableDefinition Swap (TABLE_DEFINITION_SWAP)	Number of times swapping occurred in the table definition buffer per minute because the buffer was full	AVG	float	No	7.00 or later	RZ20 (SAP-system-ID \SAP-instance-name \TableDefinition \Swap)

Legend:

Smry: Summary

Frmt: Format

Sup. ver.: Supported version

SAP Instance Summary (PD_SRV)

Function

The SAP Instance Summary (PD_SRV) record stores information about an SAP instance (equivalent to the information that can be verified by transaction code SM51).

Default and changeable values

Item	Default value	Changeable
Collection Interval	600	Y
Collection Offset	35	Y
Log	No	Y
LOGIF	(Blank)	Y
Over 10 Sec Collection Time	No	N
Realtime Report Data Collection Mode	Reschedule	Y

ODBC key fields

PD_SRV_NAME

Lifetime

From specification to change of the server name

Record size

- Fixed part: 681 bytes
- Variable part: 102 bytes

Fields

PFM - View name (PFM - Manager name)	Description	Frmt	Delta	Sup. ver.	Data source
Host (HOST)	Name of the host where the SAP instance is run	string(21)	No	7.00 or later	SM51
Instance Name (INSTANCE_NAME)	SAP instance name. This name usually consists of a host name, SAP system ID, and system number. This setting can be changed by the <code>rdisp/myname</code> parameter.	string(21)	No	7.00 or later	--
Interval (INTERVAL)	Interval in seconds at which records were stored (current value in Record Time field - previous value in Record Time field). The initial value is 0.	ulong	No	7.00 or later	--
Name (NAME)	SAP instance name. This name usually consists of a host name, SAP system ID, and system number. This setting can be	string(21)	No	7.00 or later	SM51

PFM - View name (PFM - Manager name)	Description	Frmt	Delta	Sup. ver.	Data source
Name (NAME)	changed by the <code>rdisp/myname</code> parameter.	<code>string(21)</code>	No	7.00 or later	SM51
Record Time (RECORD_TIME)	Record creation time	<code>time_t</code>	No	7.00 or later	--
Record Type (INPUT_RECORD_TYPE)	Record type (SRV)	<code>char(8)</code>	No	7.00 or later	--
Serv (SERV)	Service name	<code>string(21)</code>	No	7.00 or later	SM51
System ID (SYSTEM_ID)	SAP system ID	<code>string(9)</code>	No	7.00 or later	--
TypeList (TYPELIST)	SAP instance's type list	<code>string(9)</code>	No	7.00 or later	SM51

Legend:

Smry: Summary

Frmt: Format

Sup. ver.: Supported version

SAP Memory Summary (PI_MEM)

Function

The SAP Memory Summary (PI_MEM) record stores summary information about various SAP memories. One record is created for each SAP instance.

Default and changeable values

Item	Default value	Changeable
Collection Interval	600	Y
Collection Offset	40	Y
Log	No	Y
LOGIF	(Blank)	Y
Over 10 Sec Collection Time	No	N
Realtime Report Data Collection Mode	Reschedule	Y

ODBC key fields

None

Lifetime

None

Record size

- Fixed part: 951 bytes
- Variable part: 0 bytes

Fields

PFM - View name (PFM - Manager name)	Description	Smry	Frmt	Delta	Sup. ver.	Data source
EmSlotRecentPeak % (EM_SLOT_RECENT_P EAK)	Recent peak usage of expansion memory slots	%	float	No	7.00 or later	RZ20 (SAP-system-ID \SAP-instance-name \R3MemMgmtResources \EmSlotRecentPeak)
EmSlotsAct % (EM_SLOTS_ACT)	Current usage of expansion memory slots	%	float	No	7.00 or later	RZ20 (SAP-system-ID \SAP-instance-name \R3MemMgmtResources \EmSlotsAct)
EmSlotsPeak % (EM_SLOTS_PEAK)	Peak usage of expansion memory slots	%	float	No	7.00 or later	RZ20 (SAP-system-ID \SAP-instance-name \R3MemMgmtResources \EmSlotsPeak)
EmSlotsTotal	Total number of expansion memory slots	COPY	float	No	7.00 or later	RZ20 (SAP-system-ID \SAP-instance-name

PFM - View name (PFM - Manager name)	Description	Smry	Frmt	Delta	Sup. ver.	Data source
(EM_SLOTS_TOTAL)	Total number of expansion memory slots	COPY	float	No	7.00 or later	\R3MemMgmtResources\EmSlotsTotal)
EsAct % (ES_ACT)	Current usage of extended memory	%	float	No	7.00 or later	RZ20 (SAP-system-ID \SAP-instance-name \R3MemMgmtResources\EsAct)
EsAttached % (ES_ATTACHED)	Usage of attached extended memory	%	float	No	7.00 or later	RZ20 (SAP-system-ID \SAP-instance-name \R3MemMgmtResources\EsAttached)
EsPeak % (ES_PEAK)	Peak usage of extended memory	%	float	No	7.00 or later	RZ20 (SAP-system-ID \SAP-instance-name \R3MemMgmtResources\EsPeak)
EsRecentPeak % (ES_RECENT_PEAK)	Recent peak usage of extended memory	%	float	No	7.00 or later	RZ20 (SAP-system-ID \SAP-instance-name \R3MemMgmtResources\EsRecentPeak)
EsTotal (ES_TOTAL)	Size of extended memory in megabytes	COPY	float	No	7.00 or later	RZ20 (SAP-system-ID \SAP-instance-name \R3MemMgmtResources\EsTotal)
HeapAct % (HEAP_ACT)	Current usage of heap area	%	float	No	7.00 or later	RZ20 (SAP-system-ID \SAP-instance-name \R3MemMgmtResources\HeapAct)
HeapPeak % (HEAP_PEAK)	Peak usage of heap area	%	float	No	7.00 or later	RZ20 (SAP-system-ID \SAP-instance-name \R3MemMgmtResources\HeapPeak)
HeapRecentPeak % (HEAP_RECENT_PEAK)	Recent peak usage of heap area	%	float	No	7.00 or later	RZ20 (SAP-system-ID \SAP-instance-name \R3MemMgmtResources\HeapRecentPeak)
HeapTotal (HEAP_TOTAL)	Total size of heap area in megabytes	COPY	float	No	7.00 or later	RZ20 (SAP-system-ID \SAP-instance-name \R3MemMgmtResources\HeapTotal)
Instance Name (INSTANCE_NAME)	SAP instance name. This name usually consists of a host name, SAP system ID, and system number. This setting can be changed by the rdisp/myname parameter.	COPY	string (21)	No	7.00 or later	--
Interval (INTERVAL)	Interval in seconds at which records were stored (current value in Record Time field - previous value in Record Time field). The initial value is 0.	ADD	ulong	No	7.00 or later	--
PrivWpNo	Number of work processes placed in the PRIV mode	HILO	float	No	7.00 or later	RZ20 (SAP-system-ID \SAP-instance-name

PFM - View name (PFM - Manager name)	Description	Smry	Frmt	Delta	Sup. ver.	Data source
(PRIV_WP_NO)	Number of work processes placed in the PRIV mode	HILO	float	No	7.00 or later	\R3MemMgmtResources\PrivWpNo)
R3PagingUsed % (R3_PAGING_USED)	Usage of paging area	%	float	No	7.00 or later	RZ20 (SAP-system-ID \SAP-instance-name \R3RollPaging \R3PagingUsed)
R3RollUsed % (R3_ROLL_USED)	Usage of roll area	%	float	No	7.00 or later	RZ20 (SAP-system-ID \SAP-instance-name \R3RollPaging \R3RollUsed)
Record Time (RECORD_TIME)	Record creation time	COPY	time_t	No	7.00 or later	--
Record Type (INPUT_RECORD_TYPE)	Record type (MEM)	COPY	char (8)	No	7.00 or later	--
System ID (SYSTEM_ID)	SAP system ID	COPY	string (9)	No	7.00 or later	--
WpDiaRestart (WP_DIA_RESTART)	Number of dialog work processes whose setting is restart=Yes	AVG	float	No	7.00 or later	RZ20 (SAP-system-ID \SAP-instance-name \R3MemMgmtResources\WpDiaRestart)
WpNonDiaRestart (WP_NON_DIA_RESTART)	Number of dialog work processes whose setting is restart=No	AVG	float	No	7.00 or later	RZ20 (SAP-system-ID \SAP-instance-name \R3MemMgmtResources \WpNonDiaRestart)

Legend:

Smry: Summary

Frmt: Format

Sup. ver.: Supported version

Spool Service (PI_SPO)

Function

The Spool Service (PI_SPO) record stores statistical information about the spool service. One record is created for each SAP instance that provides this service.

Default and changeable values

Item	Default value	Changeable
Collection Interval	600	Y
Collection Offset	40	Y
Log	No	Y
LOGIF	(Blank)	Y
Over 10 Sec Collection Time	No	N
Realtime Report Data Collection Mode	Reschedule	Y

ODBC key fields

None

Lifetime

None

Record size

- Fixed part: 855 bytes
- Variable part: 0 bytes

Fields

PFM - View name (PFM - Manager name)	Description	Smry	Frmt	Delta	Sup. ver.	Data source
DeviceCacheFixed % (DEVICE_CACHE_FIXED)	Percentage of used area in the fixed device cache	%	float	No	7.00 or later	RZ20 (SAP-system-ID \SAP-instance-name \SpoolService \DeviceCacheFixed)
DeviceCacheUsed % (DEVICE_CACHE_USED)	Percentage of used area in the entire device cache	%	float	No	7.00 or later	RZ20 (SAP-system-ID \SAP-instance-name \SpoolService \DeviceCacheUsed)
HostspoolListUsed % (HOSTSPOOL_LIST_USED)	Percentage of used area in the host spool request list	%	float	No	7.00 or later	RZ20 (SAP-system-ID \SAP-instance-name \SpoolService \HostspoolListUsed)
Instance Name	SAP instance name. This name usually consists of a host name, SAP	COPY	string(21)	No	7.00 or later	--

PFM - View name (PFM - Manager name)	Description	Smry	Frmt	Delta	Sup. ver.	Data source
(INSTANCE_NAME)	system ID, and system number. This setting can be changed by the rdisp/myname parameter.	COPY	string(21)	No	7.00 or later	--
Interval (INTERVAL)	Interval in seconds at which records were stored (current value in Record Time field - previous value in Record Time field). The initial value is 0.	ADD	ulong	No	7.00 or later	--
NumberOfWpSPO (NUMBER_OF_WP_SPO)	Number of spool work processes	AVG	float	No	7.00 or later	RZ20 (SAP-system-ID \SAP-instance-name \SpoolService \NumberOfWpSPO)
QueueLength % (QUEUE_LENGTH)	Percentage of used area in the dispatcher queue	%	float	No	7.00 or later	RZ20 (SAP-system-ID \SAP-instance-name \SpoolService \QueueLength)
Record Time (RECORD_TIME)	Record creation time	COPY	time_t	No	7.00 or later	--
Record Type (INPUT_RECORD_TYPE)	Record type (SPO)	COPY	char(8)	No	7.00 or later	--
ServiceQueue % (SERVICE_QUEUE)	Percentage of used area in the spool request queue	%	float	No	7.00 or later	RZ20 (SAP-system-ID \SAP-instance-name \SpoolService \ServiceQueue)
ServiceQueuePages (SERVICE_QUEUE_PAGES)	Number of pages in the spool request queue	AVG	float	No	7.00 or later	RZ20 (SAP-system-ID \SAP-instance-name \SpoolService \ServiceQueuePages)
ServiceQueuePriv % (SERVICE_QUEUE_PRIV)	Percentage of used area in the spool request queue that is processed sequentially	%	float	No	7.00 or later	RZ20 (SAP-system-ID \SAP-instance-name \SpoolService \ServiceQueuePriv)
System ID (SYSTEM_ID)	SAP system ID	COPY	string(9)	No	7.00 or later	--
Utilization % (UTILIZATION)	Usage of spool work processes. This is the average value for all spool work processes.	%	float	No	7.00 or later	RZ20 (SAP-system-ID \SAP-instance-name \SpoolService \Utilisation)

Legend:

Smry: Summary

Frmt: Format

Sup. ver.: Supported version

System Log Monitor Command (PD_SLMX)

Function

The System Log Monitor Command (PD_SLMX) record stores the result of extracting the system log information of the SAP system. One record is created for each SAP instance.

Note

- This record cannot be displayed in real-time reports.

Default and changeable values

Item	Default value	Changeable
Collection Interval	600	Y
Collection Offset	0	Y
Log	No	Y
LOGIF	(Blank)	Y
Over 10 Sec Collection Time	No	N
Realtime Report Data Collection Mode	Reschedule	Y

ODBC key fields

None

Lifetime

None

Record size

- Fixed part: 5,073 bytes
- Variable part: 0 bytes

Fields

PFM - View name (PFM - Manager name)	Description	Frmt	Delta	Sup. ver.	Data source
Elapsed Time (ELAPSED_TIME)	Command execution time in milliseconds	ulong	No	7.00 or later	--
Exit Code (EXIT_CODE)	Command termination code	ulong	No	7.00 or later	--
Instance Name (INSTANCE_NAME)	SAP instance name. This name usually consists of a host name, SAP system ID, and system number. This setting can be changed by the <code>rdisp/myname</code> parameter.	string(21)	No	--	--
Interval (INTERVAL)	Interval in seconds at which records were stored (current value in Record	ulong	No	--	--

PFM - View name (PFM - Manager name)	Description	Frmt	Delta	Sup. ver.	Data source
Interval (INTERVAL)	Time field - previous value in Record Time field). The initial value is 0.	ulong	No	--	--
Path (PATH)	Command path (excluding the argument part)	string(256)	No	7.00 or later	--
Record Time (RECORD_TIME)	Record creation time	time_t	No	--	--
Record Type (INPUT_RECORD_TYPE)	Record type (SLMX)	char(8)	No	--	--
Stderr Buffer (STDERR_BUFFER)	Standard error output buffer for the command	string(2049)	No	7.00 or later	--
Stdout Buffer (STDOUT_BUFFER)	Standard output buffer for the command	string(2049)	No	7.00 or later	--
System ID (SYSTEM_ID)	SAP system ID	string(9)	No	--	--

Legend:

Smry: Summary

Frmt: Format

Sup. ver.: Supported version

Update1 Service (PI_UPD1)

Function

The Update1 Service (PI_UPD1) record stores statistical information about the V1 update service. One record is created for each SAP instance that provides this service.

Default and changeable values

Item	Default value	Changeable
Collection Interval	600	Y
Collection Offset	40	Y
Log	No	Y
LOGIF	(Blank)	Y
Over 10 Sec Collection Time	No	N
Realtime Report Data Collection Mode	Reschedule	Y

ODBC key fields

None

Lifetime

None

Record size

- Fixed part: 775 bytes
- Variable part: 0 bytes

Fields

PFM - View name (PFM - Manager name)	Description	Smry	Frmt	Delta	Sup. ver.	Data source
Instance Name (INSTANCE_NAME)	SAP instance name. This name usually consists of a host name, SAP system ID, and system number. This setting can be changed by the <code>rdisp/myname</code> parameter.	COPY	string(21)	No	7.00 or later	--
Interval (INTERVAL)	Interval in seconds at which records were stored (current value in Record Time field - previous value in Record Time field). The initial value is 0.	ADD	ulong	No	7.00 or later	--
NumberOfWpUD1 (NUMBER_OF_WP_UD1)	Number of update work processes	AVG	float	No	7.00 or later	RZ20 (SAP-system-ID \SAP-instance-name \PerformanceU1\NumberOfWpUD1)
QueueTime	Average wait time (in milliseconds) in the dispatcher queue	AVG	float	No	7.00 or later	RZ20 (SAP-system-ID \SAP-instance-name

PFM - View name (PFM - Manager name)	Description	Smry	Frmt	Delta	Sup. ver.	Data source
(QUEUE_TIME)	Average wait time (in milliseconds) in the dispatcher queue	AVG	float	No	7.00 or later	\PerformanceU1\QueueTime)
Record Time (RECORD_TIME)	Record creation time	COPY	time_t	No	7.00 or later	--
Record Type (INPUT_RECORD_TYPE)	Record type (UPD1)	COPY	char(8)	No	7.00 or later	--
ResponseTime (RESPONSE_TIME)	Average response time (in milliseconds) of update services	AVG	float	No	7.00 or later	RZ20 (SAP-system-ID \SAP-instance-name \PerformanceU1\ResponseTime)
System ID (SYSTEM_ID)	SAP system ID	COPY	string(9)	No	7.00 or later	--
Utilization % (UTILIZATION)	Usage of update work processes. This is the average value for all update work processes.	%	float	No	7.00 or later	RZ20 (SAP-system-ID \SAP-instance-name \PerformanceU1\Utilisation)

Legend:

Smry: Summary

Frmt: Format

Sup. ver.: Supported version

Update2 Service (PI_UPD2)

Function

The Update2 Service (PI_UPD2) record stores statistical information about the V2 update service. One record is created for each SAP instance that provides this service.

Default and changeable values

Item	Default value	Changeable
Collection Interval	600	Y
Collection Offset	40	Y
Log	No	Y
LOGIF	(Blank)	Y
Over 10 Sec Collection Time	No	N
Realtime Report Data Collection Mode	Reschedule	Y

ODBC key fields

None

Lifetime

None

Record size

- Fixed part: 775 bytes
- Variable part: 0 bytes

Fields

PFM - View name (PFM - Manager name)	Description	Smry	Frmt	Delta	Sup. ver.	Data source
Instance Name (INSTANCE_NAME)	SAP instance name. This name usually consists of a host name, SAP system ID, and system number. This setting can be changed by the <code>rdisp/myname</code> parameter.	COPY	string(21)	No	7.00 or later	--
Interval (INTERVAL)	Interval in seconds at which records were stored (current value in Record Time field - previous value in Record Time field). The initial value is 0.	ADD	ulong	No	7.00 or later	--
NumberOfWpUD2 (NUMBER_OF_WP_UD2)	Number of update work processes	AVG	float	No	7.00 or later	RZ20 (SAP-system-ID \SAP-instance-name \PerformanceU2\NumberOfWpUD2)
QueueTime	Average wait time (in milliseconds) in the dispatcher queue	AVG	float	No	7.00 or later	RZ20 (SAP-system-ID \SAP-instance-name

PFM - View name (PFM - Manager name)	Description	Smry	Frmt	Delta	Sup. ver.	Data source
(QUEUE_TIME)	Average wait time (in milliseconds) in the dispatcher queue	AVG	float	No	7.00 or later	\PerformanceU2\QueueTime)
Record Time (RECORD_TIME)	Record creation time	COPY	time_t	No	7.00 or later	--
Record Type (INPUT_RECORD_TYPE)	Record type (UPD2)	COPY	char(8)	No	7.00 or later	--
ResponseTime (RESPONSE_TIME)	Average response time (in milliseconds) of update services	AVG	float	No	7.00 or later	RZ20 (SAP-system-ID \SAP-instance-name \PerformanceU2\ResponseTime)
System ID (SYSTEM_ID)	SAP system ID	COPY	string(9)	No	7.00 or later	--
Utilization % (UTILIZATION)	Usage of update work processes. This is the average value for all update work processes.	%	float	No	7.00 or later	RZ20 (SAP-system-ID \SAP-instance-name \PerformanceU2\Utilisation)

Legend:

Smry: Summary

Frmt: Format

Sup. ver.: Supported version

User defined Monitor (Perf.) (PI_UMP)

Function

In SAP system monitor information, the User defined Monitor (Perf.) (PI_UMP) record stores performance data collected according to user definitions. One record is created for each MTE whose MTE type is the performance attribute in the specified SAP system monitor information.

Default and changeable values

Item	Default value	Changeable
Collection Interval	600	Y
Collection Offset	45	Y
Log	No	Y
LOGIF	(Blank)	Y
Over 10 Sec Collection Time	No	N
Realtime Report Data Collection Mode	Reschedule	Y

ODBC key fields

PI_UMP_MTE_NAME

Lifetime

None

Record size

- Fixed part: 833 bytes
- Variable part: 293 bytes

Fields

PFM - View name (PFM - Manager name)	Description	Smry	Frmt	Delta	Sup. ver.	Data source
Instance Name (INSTANCE_NAME)	SAP instance name. This name usually consists of a host name, SAP system ID, and system number. This setting can be changed by the rdisp/myname parameter.	COPY	string(21)	No	7.00 or later	--
Interval (INTERVAL)	Interval in seconds at which records were stored (current value in Record Time field - previous value in Record Time field). The initial value is 0.	ADD	ulong	No	7.00 or later	--
Measured Date (MEASURED_DATE)	Measured date for the performance value (Measured Value)	COPY	String(9)	No	7.00 or later	RZ20
Measured Time (MEASURED_TIME)	Measured time for the performance value (Measured Value)	COPY	String(7)	No	7.00 or later	RZ20

PFM - View name (PFM - Manager name)	Description	Smry	Frmt	Delta	Sup. ver.	Data source
Measured Value (MEASURED_VALUE)	Performance value (already obtained in the SAP system)	HILO	float	No	7.00 or later	RZ20
Monitor Name (MONITOR_NAME)	Monitor name	COPY	string(61)	No	7.00 or later	RZ20
Monitor Set (MONITOR_SET)	Monitor set name	COPY	string(61)	No	7.00 or later	RZ20
MTE Context (MTE_CONTEXT)	Name of Context part of MTE	COPY	string(41)	No	7.00 or later	RZ20
MTE Name (MTE_NAME)	MTE name (MTE's System ID part, Context part, Objectname part, and Shortname part connected by a backslash (\); for example, <i>SAP-system-ID\SAP-instance-name\Background\Utilisation</i>)	COPY	string(132)	No	7.00 or later	RZ20
MTE Objectname (MTE_OBJECTNAME)	Name of Objectname part of MTE	COPY	string(41)	No	7.00 or later	RZ20
MTE Shortname (MTE_SHORTNAME)	Name of Shortname part of MTE	COPY	string(41)	No	7.00 or later	RZ20
MTE System ID (MTE_SYSTEM_ID)	Name of System ID part of MTE	COPY	string(9)	No	7.00 or later	RZ20
Record Time (RECORD_TIME)	Record creation time	COPY	time_t	No	7.00 or later	--
Record Type (INPUT_RECORD_TYPE)	Record type (UMP)	COPY	char(8)	No	7.00 or later	--
System ID (SYSTEM_ID)	SAP system ID	COPY	string(9)	No	7.00 or later	--
Unit (UNIT)	Unit for performance value	COPY	string(5)	No	7.00 or later	RZ20
Value (VALUE)	Performance value	HILO	float	No	7.00 or later	RZ20

Legend:

Smry: Summary

Frmt: Format

Sup. ver.: Supported version

Work Process Summary (PD)

Function

The Work Process Summary (PD) record stores an overview of work processes (equivalent to the information that can be verified by transaction code SM50). One record is created for each SAP instance.

Default and changeable values

Item	Default value	Changeable
Collection Interval	60	Y
Collection Offset	35	Y
Log	Yes	Y
LOGIF	(Blank)	Y
Over 10 Sec Collection Time	No	N
Realtime Report Data Collection Mode	Reschedule	Y

ODBC key fields

PD_NO

Lifetime

From specification to a change in the number of work processes

Record size

- Fixed part: 681 bytes
- Variable part: 273 bytes

Fields

PFM - View name (PFM - Manager name)	Description	Frmt	Delta	Sup. ver.	Data source
Action (ACTION)	Activity name of the work process	string(26)	No	7.00 or later	SM50
Bname (BNAME)	User name of the request the work process is currently processing	string(13)	No	7.00 or later	SM50
CPU (CPU)	Reserved field; not available for use	string(9)	No	7.00 or later	SM50
Dumps (DUMPS)	Number of times the work process terminated abnormally	string(3)	No	7.00 or later	SM50
ElTime (ELTIME)	Duration of the work process (in seconds)	string(7)	No	7.00 or later	SM50
Instance Name (INSTANCE_NAME)	SAP instance name. This name usually consists of a host name, SAP system ID, and system number. This setting can be	string(21)	No	7.00 or later	--

PFM - View name (PFM - Manager name)	Description	Frmt	Delta	Sup. ver.	Data source
Instance Name (INSTANCE_NAME)	changed by the <code>rdisp/myname</code> parameter.	string(21)	No	7.00 or later	--
Interval (INTERVAL)	Interval in seconds at which records were stored (current value in Record Time field - previous value in Record Time field). The initial value is 0.	ulong	No	7.00 or later	--
ManDt (MANDT)	Client name of the request the work process is currently processing	string(4)	No	7.00 or later	SM50
No (NO)	Work process number	string(3)	No	7.00 or later	SM50
Pid (PID)	Process ID of the work process in the host system	string(9)	No	7.00 or later	SM50
Record Time (RECORD_TIME)	Record creation time	time_t	No	7.00 or later	--
Record Type (INPUT_RECORD_TYPE)	Record type (PD)	char(8)	No	7.00 or later	--
Report (REPORT)	Name of the report the work process is executing	string(41)	No	7.00 or later	SM50
Restart (RESTART)	Y or N indicating whether the work process will be re-executed automatically in the event of abnormal termination.	string(5)	No	7.00 or later	SM50
Sem (SEM)	Semaphore number at which the work process is in wait status	string(3)	No	7.00 or later	SM50
Server (SERVER)	Server name	string(21)	No	7.00 or later	SM50
Status (STATUS)	Current status of the work process (example: Waiting or Running)	string(8)	No	7.00 or later	SM50
System ID (SYSTEM_ID)	SAP system ID	string(9)	No	7.00 or later	--
Table (TABLE)	Name of the last database table that was accessed by the work process	string(31)	No	7.00 or later	SM50
Typ (TYP)	Type of work process (such as DIA, UPD, UP2, ENQ, BGD, or SPO)	string(4)	No	7.00 or later	SM50
WaitInf (WAITINF)	Additional information about the reason for waiting	string(41)	No	7.00 or later	SM50
WaitTim (WAITTIM)	Wait start time	string(9)	No	7.00 or later	SM50
Waiting (WAITING)	Reason why the work process is in wait status	string(6)	No	7.00 or later	SM50

Legend:

Smry: Summary

Frmt: Format

Sup. ver.: Supported version

WorkLoad Summary Interval (PI)

Function

The WorkLoad Summary Interval (PI) record stores information needed to obtain and analyze the dialog task's workload time statistics. One record is created for each SAP instance.

Default and changeable values

Item	Default value	Changeable
Collection Interval	60	Y
Collection Offset	0	Y
Log	Yes	Y
LOGIF	(Blank)	Y
Over 10 Sec Collection Time	No	N
Realtime Report Data Collection Mode	Reschedule	Y

ODBC key fields

None

Lifetime

None

Record size

- Fixed part: 1,075 bytes
- Variable part: 0 bytes

Fields

PFM - View name (PFM - Manager name)	Description	Smry	Frmt	Delta	Sup. ver.	Data source
CUA HitRatio % (CUA_HIT_RATIO)	Percentage of the database queries that were not passed to the database because they were found in the CUA buffer. For details about the CUA buffer, see the SAP Buffer Summary (PI_BUFF) record.	%	float	No	7.00 or later	RZ20 (SAP-system-ID \SAP-instance-name \CUA\HitRatio)
DBRequestTime (DB_REQUEST_TIME)	Average time for processing logical database requests in milliseconds	AVG	float	No	7.00 or later	RZ20 (SAP-system-ID \SAP-instance-name \Dialog \DBRequestTime)
DialogSteps (DIALOG_STEPS)	Average number of dialog steps per minute	AVG	float	No	7.00 or later	RZ20 (SAP-system-ID \SAP-instance-name \Dialog \DialogSteps)
EsAct %	Current usage of extended memory	%	float	No	7.00 or later	RZ20 (SAP-system-ID \SAP-instance-name

PFM - View name (PFM - Manager name)	Description	Smry	Frmt	Delta	Sup. ver.	Data source
(ES_ACT)	Current usage of extended memory	%	float	No	7.00 or later	\R3MemMgmtResources\EsAct)
FieldDescription HitRatio % (FIELD_DESCRIPTION_HIT_RATIO)	Percentage of the database queries that were not passed to the database because they were found in the field description buffer. For details about the field description buffer, see the SAP Buffer Summary (PI_BUFF) record.	%	float	No	7.00 or later	RZ20 (SAP-system-ID \SAP-instance-name \FieldDescription \HitRatio)
FrontendNetTime (FRONTEND_NET_TIME)	Network time (in milliseconds) used for the first data transfer from front end to application server and for the last data transfer from application server to front end. This does not include the value of the GuiCallBackTime field.	AVG	float	No	7.00 or later	RZ20 (SAP-system-ID \SAP-instance-name \Dialog \FrontEndNetTime)
FrontendResponseTime (FRONTEND_RESPONSE_TIME)	Average time (in milliseconds) the user waited at the front end for a request to be processed. This is the average of the totals of response time, network transfer time, and front-end processing time.	AVG	float	No	7.00 or later	RZ20 (SAP-system-ID \SAP-instance-name \Dialog \FrontendResponseTime)
GenericKey HitRatio % (GENERIC_KEY_HIT_RATIO)	Percentage of the database queries that were not passed to the database because they were found in the generic key buffer. For details about the generic key buffer, see the SAP Buffer Summary (PI_BUFF) record.	%	float	No	7.00 or later	RZ20 (SAP-system-ID \SAP-instance-name \GenericKey \HitRatio)
HeapAct % (HEAP_ACT)	Current usage of the heap area	%	float	No	7.00 or later	RZ20 (SAP-system-ID \SAP-instance-name \R3MemMgmtResources\HeapAct)
InitialRecords HitRatio % (INITIAL_RECORDS_HIT_RATIO)	Percentage of the database queries that were not passed to the database because they were found in the initial records buffer. For details about the initial records buffer, see the SAP Buffer Summary (PI_BUFF) record.	%	float	No	7.00 or later	RZ20 (SAP-system-ID \SAP-instance-name \InitialRecords \HitRatio)
Instance Name (INSTANCE_NAME)	SAP instance name. This name usually consists of a host name, SAP system ID, and system number. This setting can be changed by the rdisp/myname parameter.	COPY	string(21)	No	7.00 or later	--
Interval (INTERVAL)	Interval in seconds at which records were stored (current value in Record Time field - previous value in Record Time field). The initial value is 0.	ADD	ulong	No	7.00 or later	--
Load+GenTime (LOAD_GENTIME)	Average loading and creation time (in milliseconds) for source text, graphical user interface, and	AVG	float	No	7.00 or later	RZ20 (SAP-system-ID \SAP-instance-name \Dialog\Load+GenTime)

PFM - View name (PFM - Manager name)	Description	Smry	Frmt	Delta	Sup. ver.	Data source
Load+GenTime (LOAD_GENTIME)	window information from the database.	AVG	float	No	7.00 or later	RZ20 (SAP-system-ID \SAP-instance-name \Dialog\Load+GenTime)
PrivWpNo (PRIV_WP_NO)	Number of work processes placed in the PRIV mode	HI	float	No	7.00 or later	RZ20 (SAP-system-ID \SAP-instance-name \R3MemMgmtResources\PrivWpNo)
Program HitRatio % (PROGRAM_HIT_RATIO)	Percentage of the database queries that were not passed to the database because they were found in the program buffer. For details about the program buffer, see the SAP Buffer Summary (PI_BUFF) record.	%	float	No	7.00 or later	RZ20 (SAP-system-ID \SAP-instance-name \Program \HitRatio)
QueueTime (QUEUE_TIME)	Average wait time (in milliseconds) in the dispatcher queue. This is the average time user requests waited in the dispatcher queue.	AVG	float	No	7.00 or later	RZ20 (SAP-system-ID \SAP-instance-name \Dialog \QueueTime)
R3PagingUsed % (R3_PAGING_USED)	Usage of paging area	%	float	No	7.00 or later	RZ20 (SAP-system-ID \SAP-instance-name \R3RollPaging \R3PagingUsed)
R3RollUsed % (R3_ROLL_USED)	Usage of roll area	%	float	No	7.00 or later	RZ20 (SAP-system-ID \SAP-instance-name \R3RollPaging \R3RollUsed)
Record Time (RECORD_TIME)	Record creation time	COPY	time_t	No	7.00 or later	--
Record Type (INPUT_RECORD_TYPE)	Record type (PI)	COPY	char (8)	No	7.00 or later	--
ResponseTime (RESPONSE_TIME)	Average dialog step processing time in milliseconds. This is the total time required for processing a dialog step; it includes the database processing time but not the network transfer time or front-end processing time. If there is no dialog step, the average processing time of the last period in which a dialog step existed is reported.#	AVG	float	No	7.00 or later	RZ20 (SAP-system-ID \SAP-instance-name \Dialog \ResponseTime)
ResponseTime:StandardTran. (RESPONSE_TIME_STANDARD_TRAN)	Response time of standard transactions in milliseconds	AVG	float	No	7.00 or later	RZ20 (SAP-system-ID \SAP-instance-name \Dialog \ResponseTime(StandardTran.))
Screen HitRatio % (SCREEN_HIT_RATIO)	Percentage of the database queries that were not passed to the database because they were found in the screen buffer. For details about the screen buffer, see the SAP Buffer Summary (PI_BUFF) record.	%	float	No	7.00 or later	RZ20 (SAP-system-ID \SAP-instance-name \Screen \HitRatio)

PFM - View name (PFM - Manager name)	Description	Smry	Frmt	Delta	Sup. ver.	Data source
ShortNameTAB HitRatio % (SHORT_NAME_TAB_HIT_RATIO)	Percentage of the database queries that were not passed to the database because they were found in the short nametab buffer. For details about the short nametab buffer, see the SAP Buffer Summary (PI_BUFF) record.	%	float	No	7.00 or later	RZ20 (SAP-system-ID \SAP-instance-name \ShortNameTAB \HitRatio)
SingleRecord HitRatio % (SINGLE_RECORD_HIT_RATIO)	Percentage of the database queries that were not passed to the database because they were found in the single record buffer. For details about the single record buffer, see the SAP Buffer Summary (PI_BUFF) record.	%	float	No	7.00 or later	RZ20 (SAP-system-ID \SAP-instance-name \SingleRecord \HitRatio)
System ID (SYSTEM_ID)	SAP system ID	COPY	string(9)	No	7.00 or later	--
TableDefinition HitRatio % (TABLE_DEFINITION_HIT_RATIO)	Percentage of the database queries that were not passed to the database because they were found in the table definition buffer. For details about the table definition buffer, see the SAP Buffer Summary (PI_BUFF) record.	%	float	No	7.00 or later	RZ20 (SAP-system-ID \SAP-instance-name \TableDefinition \HitRatio)
UsersLoggedIn (USERS_LOGGED_IN)	Number of users logged on	HILO	float	No	7.00 or later	RZ20 (SAP-system-ID \SAP-instance-name \Dialog \UsersLoggedIn)

Legend:

Smry: Summary

Frmt: Format

Sup. ver.: Supported version

#

The average dialog step processing time is not updated in the SAP system during any period in which no dialog step exists. In this case, the average processing time of the last dialog step updated in the SAP system (the average processing time of the last period in which a dialog step existed) is reported. For details about this processing, see [Notes about records of the PI record type](#) in [Notes about records](#) in [Chapter 10. Records](#).

11

Commands

This chapter describes the commands provided by PFM - Agent for Enterprise Applications.

The format of the command explanations and the syntax rules are the same for both Windows and Linux.

In Windows, you execute commands from the command prompt.

In Linux, you execute commands from the control terminal.

Format of command explanations

This section describes the format of the command explanations, the specification method for commands, and the symbols used to explain the command syntax.

Command specification method

The command specification format is as follows:

```

jpcxxx [-option-A [value-a [, value-b [, value-c... ]]]] ... (1)
        [-option-B [value-a [, value-b [, value-c... ]]]] ... (1)
        [any-name-X[any-name-Y[any-name-Z ... ]]] } ... (2)
    
```

(1) indicates an *option*, and (2) indicates the *arguments*.

Symbols used to explain the command syntax

The following table lists the symbols used to explain the command syntax:

Table 11–1: Symbols used to explain the command syntax

Symbol	Description and example
 (vertical bar)	Only one of the options separated by a vertical bar can be used at one time. Example: A B C indicates A, or B, or C.
{ } (curly brackets)	One of the items enclosed in braces and separated by a vertical bar must be specified. Example: {A B C} indicates that one of the items from A, or B, or C must be specified.
[] (square brackets)	The item or items enclosed in brackets are optional. Example: [A] indicates the specification of A or nothing. [B C] indicates the specification of B or C, or nothing.
. . . (ellipsis)	The item or items preceding the ellipsis (...) can be repeated. To specify multiple items, use a one-byte space to delimit them. Example: A B . . . indicates that B can be specified as many times as necessary after A.
<u> </u> (underline)	The underlined characters are the system default when you omit all the items enclosed in brackets. Example: [<u>A</u> B] indicates that the system uses A if you do not specify either A or B.

Wildcard characters

You can specify wildcard characters in a command so that the command's processing applies to multiple services or host names. The supported wildcard characters are as follows:

- *: Indicates a string of any number of characters (including a single character)
- ?: Indicates any single character

In Linux, a wildcard character must be enclosed in double quotation marks (") so that it is not analyzed by the shell.

Notes common to all commands

Before you can execute a command, you must set the command installation directory to be the current directory. For details about the command installation directory, see the descriptions of the commands.

List of commands

The table below lists the PFM - Agent for Enterprise Applications commands.

The commands are explained in detail in the remainder of this chapter; the commands are listed in the table and explained in the chapter in alphabetical order.

Table 11–2: List of PFM - Agent for Enterprise Applications commands

Command name	Function	Executing host	Required execution permission	
			Windows	Linux
<code>jr3alget</code>	Extracts the CCMS alert information of the SAP system.	PFM - Agent for Enterprise Applications	None	None
<code>jr3slget</code>	Extracts the system log information of the SAP system.	PFM - Agent for Enterprise Applications	None	None

jr3alget

Format

```
jr3alget    [RFC-connection-information]
            [target-information]
            [-lasttime timestamp-file-name]
            [output-destination]
            [-cnf environment-parameters-file-name]
            [-help]
            [-v]
```

Function

The `jr3alget` command extracts the CCMS alert information of the SAP system.

Host that can execute the command

PFM - Agent for Enterprise Applications

Execution permissions

In Windows:

None

In Linux:

None

Command installation directory

In Windows:

```
installation-folder\agtm\evtrap\
```

In Linux:

```
/opt/jp1pc/agtm/evtrap/
```

Arguments

RFC-connection-information

Specifies the information needed to establish RFC connection with the SAP system for command execution.

You can omit specification of this argument if you have specified the RFC connection information in the environment parameters file (CONNECT section). If the RFC connection information is specified in both the environment parameters file and the command, the command specification takes effect. For details about the environment parameters file, see [6.4.3 Environment parameters file for extracting CCMS alert information by command execution](#).

The following describes the RFC information argument:

`-h application-server-host-name`

Specifies as 1-100 single-byte alphanumeric characters the name of the connection-target application server host. You must specify one of the following:

- Host name specified in the `hosts` file

- IP address
- SAP router address

You can verify the application server host name by transaction code SM51.

When you specify this option, you must also specify the `-s` option.

`-s system-number`

Specifies the system number for identification by the application server host specified with the `-h` option. You must specify a value in the range 0-99.

When you specify this option, you must also specify the `-h` option.

`-c client-name`

Specifies as 1-3 bytes the client name of the user that is to be used for connection. You must specify a value in the range 0-999.

When you specify this option, you must also specify the `-u` option together with the `-p` or `-p2` option.

`-u user-name`

Specifies as 1-12 single-byte alphanumeric characters the user name that is to be used for connection.

When you specify this option, you must also specify the `-c` option together with the `-p` or `-p2` option.

For details about the SAP users that can be specified, see [SAP users used for establishing connection](#).

`-p password`

Specifies the password for the user specified in the `-u` option. The permitted value is 1-8 single-byte characters.

This option and the `-p2` option are mutually exclusive.

When you specify this option, you must also specify the `-c` and `-u` options.

Specify this option when the SAP system is applying the conventional password rules.

For details about the characters permitted for the password, see [SAP users used for establishing connection](#).

`-p2 extended-password`

Specifies the extended password for the user specified in the `-u` option. The permitted value is 1-40 single-byte characters. This value is case sensitive.

This option and the `-p` option are mutually exclusive.

When you specify this option, you must also specify the `-c` and `-u` options.

Specify this option when the SAP system is applying the extended password rules.

For details about the characters permitted for the extended password, see [SAP users used for establishing connection](#).

`-l language`

Specifies the language for the user specified with the `-u` option. You must specify a double-byte ISO ID or a single-byte language key used in the SAP system. For example:

- To specify Japanese: JA
- To specify a language other than Japanese: EN

If you omit this option, the user's language used in the connection-target system is assumed.

When you specify this option, you must also specify the `-c` option, the `-u` option, and the `-p` or `-p2` option.

`-codepage code-page`

Specifies the code page to be used when character encoding is converted in the Unicode version of the SAP system.

The code page must be specified together with a language in the `-l` option.

Specify the combination of language and code page as shown below. If any other combination of language and code page is specified, an encoding error may occur in the information acquired from the SAP system.

Table 11–3: Combination of language and code page specifications

Connection-target SAP system	Connection language	Language (-l)	Code page (-codepage)
Unicode version	Japanese	JA	8000
	English	EN	No need to specify. If you specify a code page, specify 1100.
Non-Unicode version	Japanese	JA	No need to specify. If you specify a code page, specify 8000.
	English	EN	No need to specify. If you specify a code page, specify 1100.

To set the code page to be used to convert character codes at the connection-target SAP system (Unicode version), you can also use the `SAP_CODEPAGE` environment variable provided by the SAP system. If the code page setting is specified in both the `SAP_CODEPAGE` environment variable and in this option, this option takes effect. If this option is omitted, the connection-target system's default code page is assumed. When you specify this option, you must also specify the `-c` option, the `-u` option, and the `-p` or `-p2` option.

target-information

Specifies information that identifies the CCMS alert information that is to be extracted.

You can omit specification of this argument if you have specified the target information in the environment parameters file (`TARGET` section). If target information is specified in both the environment parameters file and the command, the command specification takes effect. For details about the environment parameters file, see [6.4.3 Environment parameters file for extracting CCMS alert information by command execution](#).

The following describes the target information argument:

`-ms monitor-set-name`

Specifies as 1-60 single-byte alphanumeric characters the monitor set name. The monitor set name is displayed as CCMS monitor set on the Alert Monitor (transaction code `RZ20`) of the SAP system.

When you specify this option, you must also specify the `-mn` option.

`-mn monitor-name`

Specifies as 1-60 single-byte alphanumeric characters the monitor name defined in the monitor set. The monitor name is displayed in the tree of the CCMS monitor set on the Alert Monitor (transaction code `RZ20`) of the SAP system.

When you specify this option, you must also specify the `-ms` option.

`-lasttime timestamp-file-name`

If only the CCMS alert information that was output after the previous command execution is to be extracted, this option specifies the name of the timestamp file used for managing the previous extraction time.

The permitted value is 1-255 single-byte characters.

If you specify a relative path, make sure that it is relative to the work directory for the command. If you have not specified a work directory for the command in the `WORKDIR` label of the `COMMAND` section in the environment parameters file, specify the path relative to the current directory.

If you omit this option, the system assumes the period from 00:00:00 to 23:59:59 on the command execution date.

If the specified timestamp file does not exist the first time the command is executed with this argument specified, a new timestamp file is created. CCMS alert information is not output during such a first-time execution.

output-destination

Specifies the output destination of the CCMS alert information. When you omit this argument, CCMS alert information separated by linefeed codes is output to the standard output.

There are two different file formats used by PFM - Agent for Enterprise Applications to output CCMS Alert Information as described below.

- WRAP1

This file is in wraparound format, which means that data is overwritten when the amount of CCMS Alert Information reaches a specified value. There can be only one output file when using this format.

- WRAP2

In this file format, when the amount of CCMS Alert Information reaches a specified value, all data is deleted from the file and then new data is written from the beginning of the file. When the amount of data in the first file reaches a specified value, new data is written in the second file, starting at the top, after all existing data is deleted from the second file. When all of the files are full, new data is again written in the first file, starting at the top, after all existing data is deleted from the first file.

There can be two through nine output files when using this format. The default is 5 output files. The number of output files is specified in the NUM label in the EXTRACTFILE section in the environment parameter file.

If you want to change the format of output files, first stop any products monitoring the output files, and then delete the output files and their management files (if there is any).

The following describes the output destination argument:

-x The-name-of-the-storage-file-in-WRAP1-format

Specifies the relative or full path name of the WRAP1-format file in which CCMS Alert Information is to be stored. The permitted value is 1 through 251 bytes of single-byte characters.

If you specify a relative path, make sure that it is relative to the work directory for the command. If you have not specified a work directory for the command in the WORKDIR label of the COMMAND section in the environment parameters file, specify the path relative to the current directory.

There is a header line of management information at the beginning of this file.

The default file size is 1,024 kilobytes. To change the file size, use the SIZE label in the EXTRACTFILE section of the environment parameters file.

A management file having the name *storage-file-name*.ofs is created in the same directory as for the storage file. For example, if ALERT is specified as the storage file name, a management file named ALERT.ofs is created in addition to the ALERT file. If you delete the storage file, you must also delete this management file.

The -x, -x2, and -xw options are mutually exclusive.

-xw The-prefix-for-the-storage-files-in-WRAP2-format

Specifies the name of WRAP2-format file in which CCMS Alert Information is to be stored. The permitted value is 1 through 254 bytes of single-byte characters. For the actual file names, a one-byte number is added at the end of the specified file name.

A number in the range from 1 through the NUM label value is assigned to the specified file name based on the value specified in the NUM label in the EXTRACTFILE section in the environment parameter file. For example, if ALERT is specified, storage files ALERT1 through ALERT5 are created by default.

If you specify a relative path, specify a path relative to the command's working directory. If no working directory is specified for commands in the WORKDIR label of the COMMAND section in the environment parameter file, specify a path relative to the current directory.

The default file size is 10,240 kilobytes. If you want to change the file size, specify a new size in the SIZE label in the EXTRACTFILE section in the environment parameter file.

The -xw, -x, and -x2 options are mutually exclusive.

-x2

Specifies that CCMS Alert Information is to be output to the file that was specified in the X2PATH label in the EXTRACTFILE section in the environment parameter file.

The -x2, -x, and -xw options are mutually exclusive.

-cnf *environment-parameters-file-name*

Specifies the name of the environment parameters file that is to be referenced by the command. The permitted value is 1-255 bytes of single-byte characters.

If you specify a relative path, make sure that it is relative to the current directory for the command.

If you omit this argument, the system assumes `jr3alget.ini`, which is the default environment parameters file in the current directory. If there is no default environment parameters file, PFM - Agent for Enterprise Applications assumes the default settings for an environment parameters file.

For details about the environment parameters file and the default settings, see [6.4.3 Environment parameters file for extracting CCMS alert information by command execution](#).

-help

Specifies that the usage of the `jr3alget` command is to be displayed at the standard output.

-v

Specifies that a message indicating the processing status of the `jr3alget` command is to be output to the standard output. If you omit this option, no message indicating the processing status of the command will be output.

SAP users used for establishing connection

To collect CCMS alert information, the `jr3alget` command executes the external management interfaces defined in the SAP system using RFC (communication protocol of SAP AG). For details, see [3.1.5\(2\) Creating SAP users that are to be used by PFM - Agent for Enterprise Applications](#).

Notes

- Because the CCMS alert information is treated as an SAP system resource and can be referenced from any application server, the connection target can be any application server. Make sure that only one command is executed per SAP system.
- To use the remote monitoring function, you have to specify information (host name, instance name, etc.) regarding the SAP system to be monitored for the following settings: the RFC connection information or target information to be specified as a command argument, and the `CONNECT` section in the environment parameters file.

Output format and contents

The following is the default output format for CCMS alert information, where `<>` enclose a field ID:

```
<ALERTDATE><ALERTTIME><MTSYSID><MTMCNAME><OBJECTNAME><FIELDNAME><VALUE><SEVERITY><MSG>
```

If the value of a CCMS alert information item is shorter than the predefined field length, the remaining area is padded with single-byte spaces. The following table lists and explains the values that are output:

Table 11–4: CCMS alert information that is output

Field ID	Description	Source	Length (bytes)
<ALSYSID>	Name of the SAP system	Alert ID (AID) (BAPIAID)	8
<MSEGNAME>	Name of the monitoring segment		40
<ALUNIQNUM>	Unique ID used by AID		10
<ALERTDATE>	Date the alert occurred (YYYYMMDD)		8
<ALERTTIME>	Time the alert occurred (HHMMSS)		6

Field ID	Description	Source	Length (bytes)
<MTSYSID>	Name of the SAP system	ID of the MTE associated with the alert (TID) (BAPITID)	8
<MTCLASS>	MTE type		3
<MTNUMRANGE>	Range of numbers (such as resident or temporary)		3
<MTMCNAME>	Name of the monitoring context		40
<MTUID>	Unit ID used by TID		10
<VALUE>	Warning value (corresponding to the color of the CCMS alert entry that can be viewed with transaction code RZ20): <ul style="list-style-type: none"> • 0: Gray (invalid information) • 1: Green (OK) • 2: Yellow (warning) • 3: Red (problem or error) 	Alert severity level (BAPIALDATA)	11
<SEVERITY>	Severity level (0-255; severity increases as the value increases)		
<FIELDNAME>	Abbreviation of MTE	General property (BAPIALERT)	40
<STATUS>	Alert status		11
<OBJECTNAME>	Name of the monitoring object		40
<MANDT>	Client		3
<USERID>	SAP user		12
<REPORTEDBY>	Reporter (logical name)		16
<STATCHGDAT>	Last date the status changed		8
<STATCHGBY>	Last user who changed the status (logical name)		16
<STATCHGTIM>	Last time the status changed		6
<MSCGLID>	Message ID when a message with the log attribute activated an alert		50
<MSGCLASS>	Message recorder		Message
<MSGID>	Message ID	30	
<MSGARG1>	Character string for message insert word 1	128	
<ARGTYPE1>	Type of message insert word 1	1	
<MSGARG2>	Character string for message insert word 2	128	
<ARGTYPE2>	Type of message insert word 2	1	
<MSGARG3>	Character string for message insert word 3	128	
<ARGTYPE3>	Type of message insert word 3	1	
<MSGARG4>	Character string for message insert word 4	128	

Field ID	Description	Source	Length (bytes)
<ARGTYPE4>	Type of message insert word 4	Message	1
<MSGTEXT>	Message text		128
<MSG>	Translated message		255

Return value

0	Normal termination
1 or greater	Abnormal termination

Example

This example outputs CCMS alert information using SAP CCMS Monitor Templates as the monitor set name and Entire System as the monitor name. The RFC connection information has already been defined in the environment parameters file.

```
jr3alget -ms "SAP CCMS Monitor Templates" -mn "Entire System"
```

The output example from this command is as follows:

```
20030321171911SD5 o246bci_SD5_00 Background AbortedJobs Job
DBA:CHECKOPT_@021500/6007 (ID number 02153101)
terminated20030321171911SD5 o246bci_SD5_00 GenericKey SpaceUsed 95 % > 90 %
15 min. avg. value over threshold value
```

jr3slget

Format

```
jr3slget    [RFC-connection-information]
            [target-information]
            [-lasttime timestamp-file-name]
            [output-destination]
            [-cnf environment-parameters-file-name]
            [-help]
            [-v]
```

Function

The `jr3slget` command extracts the system log information of the SAP system.

Host that can execute the command

PFM - Agent for Enterprise Applications

Execution permissions

In Windows:

None

In Linux:

None

Command installation directory

In Windows:

```
installation-folder\agtm\evtrap\
```

In Linux:

```
/opt/jplpc/agtm/evtrap/
```

Arguments

RFC-connection-information

Specifies the information needed to establish RFC connection with the SAP system for command execution.

You can omit specification of this argument if you have specified the RFC connection information in the environment parameters file (CONNECT section). If the RFC connection information is specified in both the environment parameters file and the command, the command specification takes effect. For details about the environment parameters file, see [5.4.3 Environment parameters file for extracting system log information by command execution](#).

The following describes the RFC information argument:

`-h application-server-host-name`

Specifies as 1-100 single-byte alphanumeric characters the name of the connection-target application server host. You must specify one of the following:

- Host name specified in the `hosts` file
- IP address

- SAP router address

You can verify the application server host name by transaction code SM51.

When you specify this option, you must also specify the `-s` option.

`-s` *system-number*

Specifies the system number for identification by the application server host specified with the `-h` option. You must specify a value in the range 0-99.

When you specify this option, you must also specify the `-h` option.

`-c` *client-name*

Specifies as 1-3 bytes the client name of the user that is to be used for connection. You must specify a value in the range 0-999.

When you specify this option, you must also specify the `-u` option together with the `-p` or `-p2` option.

`-u` *user-name*

Specifies as 1-12 single-byte alphanumeric characters the user name that is to be used for connection.

When you specify this option, you must also specify the `-c` option together with the `-p` or `-p2` option.

For details about the SAP users that can be specified, see *SAP users used for establishing connection*.

`-p` *password*

Specifies the password for the user specified in the `-u` option. The permitted value is 1-8 single-byte characters.

This option and the `-p2` option are mutually exclusive.

When you specify this option, you must also specify the `-c` and `-u` options.

Specify this option when the SAP system is applying the conventional password rules.

For details about the characters permitted for the password, see *SAP users used for establishing connection*.

`-p2` *extended-password*

Specifies the extended password for the user specified in the `-u` option. The permitted value is 1-40 single-byte characters. This value is case sensitive.

This option and the `-p` option are mutually exclusive.

When you specify this option, you must also specify the `-c` and `-u` options.

Specify this option when the SAP system is applying the extended password rules.

For details about the characters permitted for the extended password, see *SAP users used for establishing connection*.

`-l` *language*

Specifies the language for the user specified with the `-u` option. You must specify a double-byte ISO ID or a single-byte language key used in the SAP system. For example:

- To specify Japanese: JA
- To specify a language other than Japanese: EN

If you omit this option, the user's language used in the connection-target system is assumed.

When you specify this option, you must also specify the `-c` option, the `-u` option, and the `-p` or `-p2` option.

`-codepage` *code-page*

Specifies the code page to be used when character encoding is converted in the Unicode version of the SAP system. The code page must be specified together with a language in the `-l` option.

Specify the combination of language and code page as shown below. If any other combination of language and code page is specified, an encoding error may occur in the information acquired from the SAP system.

Table 11–5: Combination of language and code page specifications

Connection-target SAP system	Connection language	Language (-l)	Code page (-codepage)
Unicode version	Japanese	JA	8000
	English	EN	No need to specify. If you specify a code page, specify 1100.
Non-Unicode version	Japanese	JA	No need to specify. If you specify a code page, specify 8000.
	English	EN	No need to specify. If you specify a code page, specify 1100.

To set the code page to be used to convert character codes at the connection-target SAP system (Unicode version), you can also use the `SAP_CODEPAGE` environment variable provided by the SAP system. If the code page setting is specified in both the `SAP_CODEPAGE` environment variable and in this option, this option takes effect. If this option is omitted, the connection-target system's default code page is assumed. When you specify this option, you must also specify the `-c` option, the `-u` option, and the `-p` or `-p2` option.

target-information

Specifies information that identifies the system log information that is to be extracted.

You can omit specification of this argument if you have specified the target information in the environment parameters file (TARGET section). If target information is specified in both the environment parameters file and the command, the command specification takes effect. For details about the environment parameters file, see [5.4.3 Environment parameters file for extracting system log information by command execution](#).

The following describes the target information argument:

`-server` *SAP-instance-name*

Specifies as 1-20 single-byte alphanumeric characters the name of the SAP instance that is collecting system log information. You can specify only one SAP instance name. To check the SAP instance name, use transaction code SM50 or SM66.

`-lasttime` *timestamp-file-name*

If only the system log information that was output after the previous command execution is to be extracted, this option specifies the name of the timestamp file used for managing the previous extraction time.

The permitted value is 1-255 single-byte characters.

If you specify a relative path, make sure that it is relative to the work directory for the command. If you have not specified a work directory for the command in the `WORKDIR` label of the `COMMAND` section in the environment parameters file, specify the path relative to the current directory.

If you omit this option, the system assumes the period from 00:00:00 to 23:59:59 on the command execution date.

If the specified timestamp file does not exist the first time the command is executed with this argument specified, a new timestamp file is created. System log information is not output during such a first-time execution.

output-destination

Specifies the output destination of the system log information. When you omit this argument, system log information separated by linefeed codes is output to the standard output.

There are two different file formats used by PFM - Agent for Enterprise Applications to output system log information as described below.

- WRAP1

This file is in wraparound format, which means that data is overwritten when the amount of system log information reaches a specified value. Only one output file can be specified when using this format.

- WRAP2

In this file format, when the amount of system log information reaches a specified value, data is deleted from the file and then new data is written from the beginning of the file. When the amount of data in the first file reaches a specified value, new data is written in the second file, starting at the top, after all existing data is deleted from the second file. When all of the files are full, new data is again written in the first file, starting at the top, after all existing data is deleted from the first file.

There can be two through nine output files when using this format. The default is 5 output files. The number of output files is specified in the `NUM` label in the `EXTRACTFILE` section in the environment parameter file.

If you want to change the format of output files, first stop any products monitoring the output files, and then delete the output files and their management files (if there is any).

The following describes the output destination argument:

-x *The-name-of-the-storage-file-in-WRAP1-format*

Specifies the relative or full path name of the `WRAP1`-format file to which system log information is to be output. The permitted value is 1 through 251 bytes of single-byte characters.

If you specify a relative path, make sure that it is relative to the work directory for the command. If you have not specified a work directory for the command in the `WORKDIR` label of the `COMMAND` section in the environment parameters file, specify the path relative to the current directory.

There is a header line of management information at the beginning of this file.

The default file size is 1024 kilobytes. To change the file size, use the `SIZE` label in the `EXTRACTFILE` section of the environment parameters file.

A management file having the name *output-file-name*.`ofs` is created in the same directory as for the output file. For example, if `SYSLOG` is specified as the output file name, a management file named `SYSLOG.ofs` is created in addition to the `SYSLOG` file. If you delete the output file, you must also delete this management file.

The `-x`, `-x2`, and `-xw` options are mutually exclusive.

-xw *The-prefix-for-the-storage-files-in-WRAP2-format*

Specifies the name of `WRAP2`-format file in which system log information is to be stored. The permitted value is 1 through 254 bytes of single-byte characters. For the actual file name, a one-byte number is added at the end of the specified file name.

A number in the range from 1 through `NUM` label value is assigned to the specified file name based on the value specified in the `NUM` label in the `EXTRACTFILE` section in the environment parameter file. For example, if `SYSLOG` is specified, storage files `SYSLOG1` through `SYSLOG5` are created by default.

If you specify a relative path, specify a path relative to the command's working directory. If no working directory is specified for commands in the `WORKDIR` label of the `COMMAND` section in the environment parameter file, specify a path relative to the current directory.

The default file size is 10,240 kilobytes. If you want to change the file size, specify a new size in the `SIZE` label in the `EXTRACTFILE` section in the environment parameter file.

The `-xw`, `-x`, and `-x2` options are mutually exclusive.

-x2

Specifies that system log information is to be output to the file that was specified in the `X2PATH` label in the `EXTRACTFILE` section in the environment parameter file.

The `-x2`, `-x`, and `-xw` options are mutually exclusive.

-cnf *environment-parameters-file-name*

Specifies the name of the environment parameters file that is to be referenced by the command. The permitted value is 1-255 bytes of single-byte characters.

If you specify a relative path, make sure that it is relative to the current directory for the command.

If you omit this argument, the system assumes `jr3slget.ini`, which is the default environment parameters file in the current directory. If there is no default environment parameters file, PFM - Agent for Enterprise Applications assumes the default settings for an environment parameters file.

For details about the environment parameters file and the default settings, see [5.4.3 Environment parameters file for extracting system log information by command execution](#).

`-help`

Specified that the usage of the `jr3slget` command is to be displayed at the standard output.

`-v`

Specifies that a message indicating the processing status of the `jr3slget` command is to be output to the standard output. If you omit this option, no message indicating the processing status of the command will be output.

SAP users used for establishing connection

To collect system log information, the `jr3slget` command executes the external management interfaces defined in the SAP system using RFC (communication protocol of SAP AG). Therefore, you must provide in advance the users who are to be used by the `jr3slget` command for establishing connection in the SAP system. For details, see [3.1.5\(2\) Creating SAP users that are to be used by PFM - Agent for Enterprise Applications](#).

Note

To use the remote monitoring function, you have to specify information (host name, instance name, etc.) regarding the SAP system to be monitored for the following settings: the RFC connection information or target information to be specified as a command argument, and the `CONNECT` section in the environment parameters file.

Output format and contents

The command extracts the system log information (including parameter record rows) that can be verified by transaction code `SM21` in the SAP system.

The following is the default output format for system log information, where `<>` enclose a field ID:

```
<TIME><INSTANCE><USER><PROGRAM><MSGNO><MSGTEXT>
```

If the value of a system log information item is shorter than the predefined field length, the remaining area is padded with single-byte spaces. The following table lists and explains the values that are output:

Table 11–6: System log information that is output

Field ID	Description	Length (bytes)
<code><TIME></code>	Time the message was recorded (<i>HH:MM:SS</i>)	8
<code><INSTANCE></code>	Server that recorded the message	20
<code><USER></code>	User who recorded the message	12
<code><PROGRAM></code>	Program that recorded the message	8
<code><MSGNO></code>	Message number	3
<code><MSGTEXT></code>	Message text	255

Return value

0	Normal termination
1 or greater	Abnormal termination

Example

This example outputs the system log information for the o246bci_SD5_00 SAP instance. The RFC connection information has already been defined in the environment parameters file.

```
jr3slget -server o246bci_SD5_00
```

The output example from this command is as follows:

```
13:58:04o246bci_SD5_00 SAPSYS SAPMSSY8R49Communication error, CPIC return code 027,  
SAP return code 456  
13:58:04o246bci_SD5_00 SAPSYS SAPMSSY8R64> CPI-C function: CMINIT(SAP)
```

12

Messages

This chapter describes the format of the PFM - Agent for Enterprise Applications messages, lists the locations to which messages are output, shows which messages are output to syslog and the Windows event log, and describes the messages in detail.

12.1 Message format

This section explains the format of messages issued by PFM - Agent for Enterprise Applications. It also describes the notations used in this manual to explain the messages.

12.1.1 Format of output messages

This section explains the format of the messages issued by PFM - Agent for Enterprise Applications. Each message consists of the message ID, followed by the message text. The message format is as follows:

```
KAVFnnnnn-Y message-text
```

The message ID is composed of the following elements:

K

Identifier of the system.

AVF

Indicates a PFM - Agent message.

nnnnn

Message number. PFM - Agent for Enterprise Applications message numbers are in the format 14xxx.

Y

Type of message:

- **E: Error**
Error message issued when the system cancels processing.
- **W: Warning**
Error message issued when the system resumes processing after the message has been output.
- **I: Information**
Message in which the system provides the user with information.
- **Q: Query**
Message in which the system prompts the user for a response.

The following are the correspondences between the message type and the syslog priority level:

-E

- Level: LOG_ERR
- Description: Error message

-W

- Level: LOG_WARNING
- Description: Warning message

-I

- Level: LOG_INFO
- Description: Additional information message

-Q

(Not output)

The following are the correspondences between the message type and the Windows event log type:

-E

- Level: Error
- Description: Error message

-W

- Level: Warning
- Description: Warning message

-I

- Level: Information
- Description: Additional information message

-Q

(Not output)

12.1.2 Format of message explanations

This section describes the format used to explain messages in this manual. The part of a message text that is shown in italics represents a variable; the actual wording in the message depends on the circumstances. The manual lists the messages in the order of the message IDs. The following illustrates the format of a message explanation:

message-ID

message-text

Explanation of the message

(S)

Explains the processing performed by the system.

(O)

Explains the action the operator should take when the message is displayed.

Reference note

When a problem occurs during operation, we recommend that you collect log information and conduct initial checking in accordance with the procedures provided in [Chapter 13. Error Handling Procedures](#).

When you conduct initial checking to determine the cause of a problem, examine all applicable log information, such as the log information for the OS (Windows event log for Windows, syslog for Linux) and the log information output by PFM - Agent for Enterprise Applications. The log information enables you to understand the details of the problem, take appropriate action, and prevent the problem from recurring in the future. We recommend that you also make a record of the operations that led up to the problem and determine whether the problem is likely to recur.

12.2 Message output destinations

This section shows the output destinations of the messages issued by PFM - Agent for Enterprise Applications.

In the table below, Y and N have the following meanings:

Y: Message is output.

N: Message is not output.

Table 12–1: PFM - Agent for Enterprise Applications message output destinations

Message ID	syslog	Windows event log	Common message log	stdout	stderr	JP1 system event#1	Extended agent event#2
KAVF14000	Y	Y	Y	N	N	N	N
KAVF14001	Y	Y	Y	N	N	N	N
KAVF14002	Y	Y	Y	N	N	N	N
KAVF14100	N	N	Y	N	N	Y	Y
KAVF14103	N	N	Y	N	N	Y	Y
KAVF14105	N	N	Y	N	N	N	N
KAVF14121	Y	Y	Y	N	N	Y	Y
KAVF14122	N	N	Y	N	N	N	N
KAVF14125	Y	Y	Y	N	N	Y	Y
KAVF14126	N	N	Y	N	N	N	N
KAVF14127	Y	Y	Y	N	N	Y	Y
KAVF14128	Y	Y	Y	N	N	Y	Y
KAVF14129	Y	Y	Y	N	N	Y	Y
KAVF14131	Y	Y	Y	N	N	Y	Y
KAVF14133	Y	Y	Y	N	N	N	N
KAVF14134	Y	Y	Y	N	N	Y	Y
KAVF14136	Y	Y	Y	N	N	Y	N
KAVF14137	Y	Y	Y	N	N	Y	Y
KAVF14140	Y	Y	Y	N	N	Y	Y
KAVF14141	Y	Y	Y	N	N	Y	Y
KAVF14150	Y	Y	Y	N	N	Y	N
KAVF14151	Y	N	Y#3	N	N	Y#3	Y#3
KAVF14152	Y	N	Y#3	N	N	Y#3	Y#3
KAVF14160	Y	Y	Y	N	N	Y	Y
KAVF14161	Y	Y	Y	N	N	Y	Y
KAVF14171	Y	Y	Y	N	N	Y	Y
KAVF14172	Y	Y	Y	N	N	Y	Y
KAVF14173	Y	Y	Y	N	N	Y	Y

Message ID	syslog	Windows event log	Common message log	stdout	stderr	JP1 system event#1	Extended agent event#2
KAVF14174	Y	Y	Y	N	N	Y	Y
KAVF14175	Y	Y	Y	N	N	Y	Y
KAVF14176	Y	Y	Y	N	N	Y	Y
KAVF14177	Y	Y	Y	N	N	Y	Y
KAVF14178	Y	Y	Y	N	N	N	N
KAVF14179	Y	Y	Y	N	N	N	N
KAVF14184	Y	Y	Y	N	N	Y	Y
KAVF14185	Y	Y	Y	N	N	Y	Y
KAVF14186	Y	Y	Y	N	N	Y	Y
KAVF14190	Y	Y	Y	N	N	Y	Y
KAVF14191	Y	Y	Y	N	N	Y	Y
KAVF14200	N	N	N	Y	N	N	N
KAVF14201	N	N	N	Y	N	N	N
KAVF14210	N	N	N	Y	N	N	N
KAVF14211	N	N	N	N	Y	N	N
KAVF14212	N	N	N	Y	N	N	N
KAVF14213	N	N	N	Y	N	N	N
KAVF14215	N	N	N	Y	N	N	N
KAVF14216	N	N	N	Y	N	N	N
KAVF14220	N	N	N	N	Y	N	N
KAVF14221	N	N	N	N	Y	N	N
KAVF14222	N	N	N	N	Y	N	N
KAVF14223	N	N	N	N	Y	N	N
KAVF14224	N	N	N	N	Y	N	N
KAVF14225	N	N	N	N	Y	N	N
KAVF14226	N	N	N	N	Y	N	N
KAVF14227	N	N	N	N	Y	N	N
KAVF14229	N	N	N	N	Y	N	N
KAVF14230	N	N	N	N	Y	N	N
KAVF14231	N	N	N	N	Y	N	N
KAVF14232	N	N	N	N	Y	N	N
KAVF14233	N	N	N	N	Y	N	N
KAVF14240	N	N	N	N	Y	N	N
KAVF14241	N	N	N	N	Y	N	N
KAVF14242	N	N	N	N	Y	N	N

Message ID	syslog	Windows event log	Common message log	stdout	stderr	JP1 system event#1	Extended agent event#2
KAVF14243	N	N	N	N	Y	N	N
KAVF14244	N	N	N	N	Y	N	N
KAVF14245	N	N	N	N	Y	N	N
KAVF14250	N	N	N	N	Y	N	N
KAVF14251	N	N	N	N	Y	N	N
KAVF14253	N	N	N	N	Y	N	N
KAVF14254	N	N	N	N	Y	N	N
KAVF14255	N	N	N	N	Y	N	N
KAVF14256	N	N	N	N	Y	N	N
KAVF14257	N	N	N	N	Y	N	N
KAVF14260	N	N	N	N	Y	N	N
KAVF14261	N	N	N	N	Y	N	N
KAVF14262	N	N	N	N	Y	N	N
KAVF14263	N	N	N	N	Y	N	N
KAVF14270	N	N	N	N	Y	N	N
KAVF14271	N	N	N	N	Y	N	N
KAVF14272	N	N	N	N	Y	N	N
KAVF14273	N	N	N	Y	N	N	N
KAVF14274	N	N	N	N	Y	N	N
KAVF14275	N	N	N	Y	N	N	N
KAVF14276	N	N	N	N	Y	N	N
KAVF14277	N	N	N	Y	N	N	N
KAVF14278	N	N	N	N	Y	N	N
KAVF14280	Y	Y	N	N	Y	N	N
KAVF14281	Y	Y	N	N	Y	N	N
KAVF14285	N	Y	N	N	Y	N	N
KAVF14286	N	Y	N	N	Y	N	N
KAVF14287	N	Y	N	N	Y	N	N
KAVF14289	N	N	N	N	Y	N	N
KAVF14290	N	N	N	N	Y	N	N

Legend:

stdout: Standard output

stderr: Standard error

#1

JP1 system events notify JP1/IM of a change in agent status. For details about the JP1 system events, see the chapter that describes the monitoring of operations linked with the integrated management product (JP1/IM) in the *JP1/Performance Management User's Guide*.

The following table shows the programs required in order to issue JP1 system events.

Table 12–2: Programs required in order to issue JP1 system events

Host type	Prerequisite program	Version
Monitoring manager	PFM - Manager	08-00 or later
Monitoring console server	PFM - Web Console	08-00 or later
Monitoring agent host	PFM - Agent for Enterprise Applications	09-00 or later
	PFM - Manager or PFM - Base	09-00 or later
	JP1/Base	09-00 or later

When the version of PFM - Manager or PFM - Base is 08-xx at the PFM - Agent host, no JP1 system events are issued. Even if the properties of the Agent Collector service have been set to issue JP1 system events, no JP1 system events will be issued.

To use JP1 system events, you must be using version 09-00 or later of PFM - Manager or PFM - Base at the PFM - Agent host.

#2

Extended agent events notify PFM - Manager of a change in agent status. For details about agent events, see the chapter that describes event display in the *JP1/Performance Management User's Guide*. Note that the extended agent events are issued only when connection is established with PFM - Manager.

The following table shows the programs required in order to issue extended agent events.

Table 12–3: Programs required in order to issue extended agent events

Host type	Prerequisite program	Version
Monitoring manager	PFM - Manager	09-00 or later
Monitoring console server	PFM - Web Console	08-00 or later
Monitoring agent host	PFM - Agent for Enterprise Applications	09-00 or later
	PFM - Manager or PFM - Base	09-00 or later

When the version of PFM - Manager or PFM - Base is 08-xx at the PFM - Agent host, no extended agent events are issued.

To use extended agent events, you must be using version 09-00 or later of PFM - Manager or PFM - Base at the PFM - Agent host.

#3

Output only in the Linux version

12.3 Messages output to syslog and Windows event log

This section lists the messages that PFM - Agent for Enterprise Applications outputs to syslog and to the Windows event log.

The syslog information is output to the syslog file (default path is `/var/log/messages*`).

The Windows event log is displayed in the following window:

The Windows event log is displayed in the application log of the Event Viewer window.

To open the Event Viewer window, from the Windows **Start** menu, choose **Administrative Tools**, and then **Event Viewer**.

For any event issued by PFM - Agent for Enterprise Applications, the identifier PFM-R3 is displayed in the **Source** column of the Event Viewer window.

The following table lists the messages that PFM - Agent for Enterprise Applications outputs to syslog and to the Windows event log:

Table 12–4: Messages output to syslog and to the Windows event log

Message ID	syslog		Windows event log	
	Facility	Level	Event ID	Level
KAVF14000-I	LOG_DAEMON	LOG_INFO	14000	Information
KAVF14001-I	LOG_DAEMON	LOG_INFO	14001	Information
KAVF14002-E	LOG_DAEMON	LOG_ERR	14002	Error
KAVF14105-I	LOG_DAEMON	LOG_INFO	14105	Information
KAVF14121-E	LOG_DAEMON	LOG_ERR	14121	Error
KAVF14125-E	LOG_DAEMON	LOG_ERR	14125	Error
KAVF14127-E	LOG_DAEMON	LOG_ERR	14127	Error
KAVF14128-E	LOG_DAEMON	LOG_ERR	14128	Error
KAVF14129-E	LOG_DAEMON	LOG_ERR	14129	Error
KAVF14131-E	LOG_DAEMON	LOG_ERR	14131	Error
KAVF14133-E	LOG_DAEMON	LOG_ERR	14133	Error
KAVF14134-E	LOG_DAEMON	LOG_ERR	14134	Error
KAVF14136-E	LOG_DAEMON	LOG_ERR	14136	Error
KAVF14137-E	LOG_DAEMON	LOG_ERR	14137	Error
KAVF14140-E	LOG_DAEMON	LOG_ERR	14140	Error
KAVF14141-E	LOG_DAEMON	LOG_ERR	14141	Error
KAVF14150-E	LOG_DAEMON	LOG_ERR	14150	Error
KAVF14151-E	LOG_DAEMON	LOG_ERR	--	--
KAVF14152-E	LOG_DAEMON	LOG_ERR	--	--
KAVF14160-I	LOG_DAEMON	LOG_INFO	14160	Information

Message ID	syslog		Windows event log	
	Facility	Level	Event ID	Level
KAVF14161-E	LOG_DAEMON	LOG_ERR	14161	Error
KAVF14171-W	LOG_DAEMON	LOG_WARNING	14171	Warning
KAVF14172-W	LOG_DAEMON	LOG_WARNING	14172	Warning
KAVF14173-W	LOG_DAEMON	LOG_WARNING	14173	Warning
KAVF14174-W	LOG_DAEMON	LOG_WARNING	14174	Warning
KAVF14175-W	LOG_DAEMON	LOG_WARNING	14175	Warning
KAVF14176-W	LOG_DAEMON	LOG_WARNING	14176	Warning
KAVF14178-W	LOG_DAEMON	LOG_WARNING	14178	Warning
KAVF14179-W	LOG_DAEMON	LOG_WARNING	14179	Warning
KAVF14183-E	LOG_DAEMON	LOG_ERR	--	--
KAVF14184-E	LOG_DAEMON	LOG_ERR	14184	Error
KAVF14185-E	LOG_DAEMON	LOG_ERR	14185	Error
KAVF14186-E	LOG_DAEMON	LOG_ERR	14186	Error
KAVF14190-E	LOG_DAEMON	LOG_ERR	14190	Error
KAVF14191-E	LOG_DAEMON	LOG_ERR	14191	Error
KAVF14280-W	LOG_DAEMON	LOG_WARNING	14280	Warning
KAVF14281-W	LOG_DAEMON	LOG_WARNING	14281	Warning

12.4 Messages

This section explains the messages issued by PFM - Agent for Enterprise Applications and the actions to be taken.

KAVF14000-I

Agent Collector has started. (host=*host-name*, service=*service-ID*)

Startup or initialization of the Agent Collector service has been completed.

(S)

Starts collecting SAP system performance data.

KAVF14001-I

Agent Collector has stopped. (host=*host-name*, service=*service-ID*)

The Agent Collector service has stopped for one of the following reasons: termination was requested by execution of the `jpcspm stop` command, the Windows service terminated, or a signal interrupt occurred.

In the case of a signal interrupt, this message is preceded by the KAVF14151-E message indicating the signal reception event and supplemental signal number.

(S)

Stops the Agent Collector service.

KAVF14002-E

Agent Collector failed to start. (rc=*maintenance-code*)

The Agent Collector service cannot continue because startup or initialization of the Agent Collector service failed.

(S)

Stops the Agent Collector service.

(O)

Check the immediately preceding message in syslog (in Linux), in the Windows event log (in Windows), or in the common message log, and then take appropriate action.

KAVF14100-I

Connected to the SAP system. (sid=*SAP-system-ID*)

RFC connection has been established with the SAP system.

(S)

Resumes initialization of the Agent Collector service.

KAVF14103-I

Reconnected to the SAP system. (sid=*SAP-system-ID*)

RFC connection has been re-established with the SAP system. This message is issued when connection had already been established with the SAP system since the Agent Collector service started but was broken for some reason, and now the connection has been re-established.

(S)

Resumes initialization of the Agent Collector service.

KAVF14105-I

The connection to the SAP system was closed. (*sid=SAP-system-ID*)

RFC connection with the SAP system has been closed.

This message is issued when processing based on a termination request is to be executed or when the RFC handle is to be released due to a transient error during operation.

(S)

If processing based on a termination request is to be executed, the system terminates the Agent Collector service.

If the RFC handle is to be released due to a transient error during operation, the system waits until the next connection.

KAVF14121-E

An error occurred in the RFC API. (*name-of-API-resulting-in-error*)

An RFC function call resulted in an error. For an RFC API error during connection establishment with the SAP system, the KAVF14127-E or KAVF14128-E message is issued instead of this message. Following this message, the KAVF14122-E message providing detailed error information is output to the common message log. Possible causes of this error are as follows:

- The SAP system is not active.
- The SAP system cannot accept an RFC request due to heavy workload.
- There is a problem in the network settings.

(S)

- When this error occurs during startup processing:

Stops the Agent Collector service.

- When this error occurs subsequent to startup processing (during operation):

Continues monitoring. The system closes any open RFC handle and re-establishes connection when the next collection begins. Updating of the performance data that was supposed to take place during this collection period will be delayed.

(O)

- When this error occurs during startup processing:

Re-evaluate the status, such as the connection parameters set in the Agent Collector service startup initialization file (`jpcagt.ini`), the operating status of the SAP system, and the network status, correct the error, and then restart.

- When this error occurs subsequent to startup processing (during operation):

A fatal error, such as SAP system shutdown, may have occurred. Check the KAVF14122-E message output to the common message log before or after the time of this error and resolve the problem.

Before correcting an error in the connection parameters in the Agent Collector service startup initialization file (`jpcagt.ini`), check if PFM - Agent for Enterprise Applications was stopped by the `jpcspm stop` command.

If this error occurred due to planned termination (such as for SAP system maintenance purposes), you can ignore this message. When the SAP system restarts, PFM - Agent for Enterprise Applications will re-establish connection and continue with monitoring.

KAVF14122-E

```
RFC_ERROR_INFO: code=return-code, group=error-group, key=error-key, message=error-message,
abapMsgClass=ABAP-message-class, abapMsgType=ABAP-message-type, abapMsgNumber=ABAP-message-
number, abapMsgV1=ABAP-message-details-field-1, abapMsgV2=ABAP-message-details-field-2,
abapMsgV3=ABAP-message-details-field-3, abapMsgV4=ABAP-message-details-field-4
```

This message follows the KAVF14121-E, KAVF14127-E, or KAVF14128-E message. It provides details of the RFC API error. The meanings of the values displayed in the message are as follows:

- `code`: RFC return code (integer)
- `group`: Integer that identifies the key
- `key`: Code that identifies the error (maximum of 127 bytes)
- `message`: Text that describes the error (might include linefeed codes) (maximum of 511 bytes)
- `abapMsgClass`: The ABAP message class (maximum of 20 bytes)
- `abapMsgType`: The ABAP message type (maximum of 1 byte)
- `abapMsgNumber`: The ABAP message number (maximum of 3 bytes)
- `abapMsgV1`: An ABAP message details field (maximum of 50 bytes of text)
- `abapMsgV2`: An ABAP message details field (maximum of 50 bytes of text)
- `abapMsgV3`: An ABAP message details field (maximum of 50 bytes of text)
- `abapMsgV4`: An ABAP message details field (maximum of 50 bytes of text)

The size of the RFC API error details is the number of bytes not including `\0`.

These are the member values in the `RFC_ERROR_INFO` structure that stores the RFC API error information. For details about RFC, see the documentation for the SAP system.

(S)

This message is preceded by the KAVF14121-E, KAVF14127-E, or KAVF14128-E message; see that message for the system processing.

(O)

Check the KAVF14121-E, KAVF14127-E, or KAVF14128-E message displayed before this message, and eliminate the cause of the error.

KAVF14125-E

```
An error occurred in the function module of the SAP system. (name-of-function-module-resulting-in-error)
```

An SAP system function module returned an unexpected error code. This message is followed in the common message log by the KAVF14126-E message that provides detailed error information. The cause of the error is defined for each function module that was called. For details about the cause of the error, see the KAVF14126-E message.

(S)

- When this error occurs during startup processing:
Stops the Agent Collector service.
- When this error occurs subsequent to startup processing (during operation):
Continues monitoring. The system postpones updating of the performance data that was supposed to take place at this time.

(O)

- When this error occurs during startup processing:
Check the version of the SAP system. `BAPI_XMI_LOGON` may result in an error during authorization checking. In such a case, grant the `SXMI_PROD` authorization object to the user who is attempting to establish connection.
- When this error occurs subsequent to startup processing (during operation):
Check the `KAVF14126-E` message output to the common message log before or after this error occurred, and resolve the problem.

KAVF14126-E

`BAPIRET2: TYPE=message-type, ID=message-class, NUMBER=message-number, MESSAGE=message-text`

This message provides the details of an error in the function module (BAPI). The meanings of the values displayed in the message are as follows:

- `TYPE`: One-byte character indicating the severity level of the message (S: normal, E: error, W: warning, I: information, A: forced termination)
- `ID`: Message class (maximum of 20 bytes)
- `NUMBER`: Error code (maximum of 3 bytes) that identifies the error
- `MESSAGE`: Text (maximum of 220 bytes) that describes the nature of the error

These are the member values in the `BAPIRET2` structure that stores a BAPI error. For details about BAPI, see the documentation for the SAP system. For details about the specification of the called BAPI, see the documentation for the SAP system's object navigator (SE80), BAPI browser (BAPI) or the SAP system.

(S)

This message is preceded by the `KAVF14125-E` message; see that message for system processing.

(O)

Check the `KAVF14125-E` message displayed before this message and eliminate the cause of the error.

KAVF14127-E

`Cannot connect to the SAP system. (name-of-the-function-resulting-in-error)`

A connection error occurred during connection establishment with the SAP system. For an RFC API error during connection establishment with the SAP system, this message or the `KAVF14128-E` message is issued instead of the `KAVF14121-E` message. Following this message, the `KAVF14122-E` message providing detailed error information is output to the common message log.

Possible causes of this error are as follows:

- The SAP system is not active.

- The SAP system cannot accept an RFC request due to heavy workload.
- There is a problem in the network settings.
- The destination information is invalid (there is an error in the information, such as host name or system number).

(S)

- When this error occurs during startup processing:
Stops the Agent Collector service.
- When this error occurs subsequent to startup processing (during operation):
Continues monitoring. The system closes any open RFC handle and re-establishes connection the next time performance data is collected. Updating of the performance data that was supposed to take place during this collection period will be delayed.

(O)

- When this error occurs during startup processing:
Re-evaluate the status, such as the connection parameters set in the Agent Collector service startup initialization file (`jpcagt.ini`), the operating status of the SAP system, and the network status, correct the error, and then restart.
- When this error occurs subsequent to startup processing (during operation):
A fatal error, such as SAP system shutdown, may have occurred. Check the `KAVF14122-E` message output to the common message log before or after the time of this error and resolve the problem.
Before correcting an error in the connection parameters in the Agent Collector service startup initialization file (`jpcagt.ini`), check if PFM - Agent for Enterprise Applications was stopped by the `jpcspm stop` command.
If this error occurred due to planned termination, such as for SAP system maintenance purposes, you can ignore this message. When the SAP system restarts, PFM - Agent for Enterprise Applications re-establishes connection and continues monitoring.

KAVF14128-E

Cannot log on to the SAP system. (*name-of-the-function-resulting-in-error*)

A logon error occurred during connection establishment with the SAP system. For an RFC API error during connection establishment with the SAP system, this message or the `KAVF14127-E` message is issued instead of the `KAVF14121-E` message. Following this message, the `KAVF14122-E` message providing detailed error information is output to the common message log. Possible causes of this error are as follows:

- The logon information is invalid (there is an error in the information, such as client name, user name, or password).
- The user's password has been changed.
- The user does not have the required authorization.
This refers to the authorization (`S_RFC`) needed to establish RFC connection with the function module (BAPI).
- An extended password containing lower-case letters is defined in the SAP system based on SAP NetWeaver 7.0 or later, but `N` (do not use extended passwords) was specified in the `EXTPWD` instance information item.

(S)

- When this error occurs during startup processing:
Stops the Agent Collector service.
- When this error occurs subsequent to startup processing (during operation):

Continues monitoring. The system closes any open RFC handle and re-establishes connection the next time performance data is collected. Updating of the performance data that was supposed to take place during this collection period will be delayed.

(O)

- When this error occurs during startup processing:
Re-evaluate the settings, such as the connection parameters in the Agent Collector service startup initialization file (`jpcagt.ini`) and the user definitions in the SAP system, correct the error, and then restart.
- When this error occurs subsequent to startup processing (during operation):
Possible causes include deletion of the user or a change in the password. Check the `KAVF14122-E` message output to the common message log before or after this error occurred, and resolve the problem.
Before correcting an error in the connection parameters in the Agent Collector service startup initialization file (`jpcagt.ini`), check if PFM - Agent for Enterprise Applications was stopped by the `jpcspm stop` command.

KAVF14129-E

SAP instance=*SAP instance-name*

This message displays the name of the SAP instance resulting in a communication error when the `KAVF14121-E` or `KAVF14127-E` message has been displayed.

(S)

This message is preceded by the `KAVF14121-E` or `KAVF14127-E` message; see that message for the system processing.

(O)

Check the `KAVF14121-E` or `KAVF14127-E` message displayed before this message, and eliminate the cause of the error.

KAVF14131-E

The system resources are insufficient.

There is a shortage in system resources, such as memory or handles. The resources required by Performance Management are insufficient or the system is unstable due to another application's resource leakage.

(S)

- When this error occurs during startup processing:
Stops the Agent Collector service.
- When this error occurs subsequent to startup processing (during operation):
The Agent Collector service attempts to continue monitoring as much as possible. A series of operations or requests is rejected, and updating of the performance data that was supposed to take place at this time is delayed.

(O)

Identify the problem as soon as possible and recover the system status. Secure the system resources by re-estimating the required resources as well as re-evaluating the memory expansion and kernel parameters.

KAVF14133-E

An error occurred in an internal function. (*func=function-name, rc=maintenance-code*)

A function error occurred in an internal function interface.

(S)

If this error occurs during startup processing, the Agent Collector service terminates abnormally. If the error occurs after completion of startup processing (during operation), the Agent service continues monitoring. However, a series of operations or requests is rejected and updating of the performance data that was supposed to take place at this time is delayed.

(O)

If the error occurs frequently and cannot be recovered, collect maintenance data and contact the system administrator. For details about how to collect maintenance data, see the chapter that describes error handling procedures in the *JPI/Performance Management User's Guide*.

KAVF14134-E

A file or directory cannot be accessed. (*path*)

An error (other than a shortage of disk space) occurred during a general file access, such as a creation, deletion, read, or write operation. Possible causes of this error are as follows:

- The file does not exist.
- There is no access permission.
- The file system has been unmounted.
- The specified file path is a directory path (invalid environment).

(S)

- When this error occurs during startup processing:
Stops the Agent Collector service.
- When this error occurs subsequent to startup processing (during operation):
The Agent Collector service attempts to continue monitoring as much as possible. A series of operations or requests is rejected, and updating of the performance data that was supposed to take place at this time is delayed.

(O)

Check the status of the file indicated by *path* in the message and correct the error.

KAVF14136-E

The content of the Agent Collector service startup initialization file is invalid. (section=*section-name*, subsection=*subsection-name*, label=*label-name*)

The Agent Collector service startup initialization file (*jpcagt.ini*) contains an invalid specification.

(S)

Cancels startup processing and stops the Agent Collector service.

(O)

Check the *section-name*, *subsection-name*, and *label-name* displayed in the message, correct the invalid specification in the Agent Collector service startup initialization file (*jpcagt.ini*), and then restart the Agent Collector service.

KAVF14137-E

A prerequisite module was not found.

A prerequisite module was not found in the system.

(S)

Terminates the Agent Collector service.

(O)

Take action according to below, and then re-execute the command. If this does not resolve the problem, collect maintenance data and contact the system administrator.

- Check whether the prerequisite OS package exists in the system.
Refer to the Release Notes for prerequisite software.

KAVF14140-E

An attempt to convert the character code failed. (source character code=*character-code-before-conversion*, destination character code=*character-code-after-conversion*)

An attempt to convert a character code failed.

(S)

When this error occurs during startup processing, the Agent service terminates abnormally.

When this error occurs after startup has finished (while operating), collection processing continues (updating of performance data is delayed until the next collection request).

(O)

Investigate whether the agent startup information file (`jpcagt.ini`) contains characters outside the Shift JIS range (excluding private-use characters, platform-dependent characters, and level 3 or level 4 kanji).

KAVF14141-E

Preparation for character code conversion failed.

The system failed to open the character code conversion table at communication with the SAP system.

(S)

Terminates the Agent Collector service.

(O)

Ensure the kernel parameter that has sufficient number of files to be opened by the system and process and try again.
If this does not resolve the problem, collect maintenance data and contact the system administrator.

KAVF14150-E

The system environment is invalid. (rc=*maintenance-code*)

The system environment is invalid. This error occurs when installation and setup are incomplete or system files and registry information have been deleted or modified erroneously. If the message catalog is not available, the message is displayed in English even in a Japanese-language environment.

(S)

Terminates the Agent Collector service abnormally.

(O)

Back up all necessary data, uninstall the system, and then re-install it. If this does not resolve the problem, collect maintenance data and then contact the system administrator. For details about how to collect maintenance data, see the chapter that describes error handling procedures in the *JPI/Performance Management User's Guide*.

KAVF14151-E

The processing was interrupted by a signal. (signal=*signal-number*)

The Agent Collector service stopped because a process termination signal was accepted as a result of an event such as system shutdown.

(S)

Stops the Agent Collector service.

KAVF14152-W

Reception of a signal caused the service to stop. (signal=*signal-number*)

In Linux, reception of the indicated signal caused the Agent Collector service to stop the processing.

(S)

Stops the Agent Collector service processing.

KAVF14160-I

The performance data will now be collected. (sid=*SAP-system-ID*, server=*SAP-instance-name*)

The Agent Collector service has started collecting performance data. At this point, all collection-related initialization processing has been completed.

(S)

Collects performance data.

KAVF14161-E

The SAP instance does not exist. (sid=*SAP-system-ID*, server=*SAP-instance-name*)

The value entered in the SID or SERVER item in the instance environment setup procedure is invalid.

(S)

- When this error occurs during startup processing:
Stops the Agent Collector service.
- When this error occurs subsequent to startup processing (during operation):
Continues monitoring. The system delays the updating of performance data that was supposed to take place at this time.

(O)

Check and, if necessary, revise the specified SID or SERVER item, and then re-execute the command. You can check the SAP instance name by using transaction code SM51. The SAP instance name is usually in the format *host-name_system-ID_system-number*.

KAVF14171-W

The performance data could not be updated. (*record-ID[field-name]*)

Collection of performance data failed. This message is preceded by a message that indicates the direct cause of the error, such as a communication error or function module (BAPI) error. This message displays the affected record ID and field name, separated by a period. The displayed record ID and field name are PFM - Manager names.

(S)

Continues with performance data collection. Updating of the performance data is delayed until the next collection request.

(O)

Eliminate the cause of the error.

KAVF14172-W

The performance data cannot be collected now.

This message indicates that performance data is not being collected due to a communications error. Performance data cannot be collected at this agent until output of the KAVF14103-I message that indicates that connection to the SAP system has been recovered, followed by output of the KAVF14160-I message indicating completion of initialization.

(S)

Attempts to reconnect with the SAP system at each collection request. Note that the subsequent connection errors are not reported. When connection with the SAP system is recovered, the system displays the KAVF14103-I message.

(O)

Check the KAVF14121-E and KAVF14122-E communication error messages displayed before this message, and eliminate the cause of the error.

KAVF14173-W

The performance data cannot be reported. (*record-ID[field-name]*)

The connection-target SAP system does not support this performance data.

No data source corresponding to the performance data was found in the connection-target SAP system.

This message displays the record ID and field name, separated by a period, of the unsupported performance data. The displayed record ID and field name are PFM - Manager names.

(S)

Stops monitoring for this performance data and resumes initialization of agent.

(O)

Check the supported performance data. For details about the supported performance data, see [Chapter 10. Records](#).

KAVF14174-W

During collection of data, the number of instances of a multi-instance record exceeded the maximum. (*record=record-ID, limit=maximum-value, instance=instances-count*)

During data collection, the number of instances for a multi-instance record exceeded the maximum value. The excess instances are being discarded.

(S)

Resumes processing.

(O)

Check and, if necessary, revise the target monitor settings.

KAVF14175-W

The specified monitor set name is invalid. (*monitor-set-name*)

One of the following may apply to the settings in the [Agent] - [PI_UMP] folder for the properties of the Agent Collector service:

- The MONITOR_SET property has not been set.
- The monitor set name that was set is undefined in the SAP system.
- The defined monitor set name is invalid.

(S)

Cancels collection of the User defined Monitor (Perf.) (PI_UMP) record and resumes processing.

(O)

Check in the [Agent] - [PI_UMP] folder for the properties of the Agent Collector service whether the monitor set name set in the MONITOR_SET property exists in the SAP system.

You can check the monitor set name by means such as transaction code RZ20. The monitor set name may be shown as *monitor set*. Note that the settings are case sensitive.

KAVF14176-W

The specified monitor name is invalid. (*monitor-name*)

One of the following may apply to the settings in the [Agent] - [PI_UMP] folder for the properties of the Agent Collector service:

- The MONITOR_SET property has not been set.
- The monitor name that was set is undefined in the SAP system.
- The defined monitor name is invalid.

(S)

Cancels collection of the User defined Monitor (Perf.) (PI_UMP) record and resumes processing.

(O)

Check in the [Agent] - [PI_UMP] folder for the properties of the Agent Collector service whether the monitor name set in the MONITOR_SET property exists in the SAP system.

You can check the monitor name by means such as transaction code RZ20. The monitor name may be shown as *monitor set*. Note that the settings are case sensitive.

KAVF14177-W

The Performance data could not be collected. (*record-ID, monitor-set-name, monitor-name, MTE-name*)

Collection of the performance data indicated by the MTE name failed (BAPI error). This message is preceded by a message that indicates the specific cause of the error, such as a communication error or function module (BAPI) error.

- (S)
Cancels collection of the performance data indicated by the MTE name and resumes processing. Updating of the performance data that was to be acquired at this time will be delayed until the next collection time.
- (O)
Check the message output immediately preceding this message and eliminate the cause of the error.

KAVF14178-W

It failed to issue JP1 system event or Agent event extension.

The Agent Collector service failed to issue a JP1 system event or an extended agent event. Any subsequent event issuance failures will not be reported.

- (S)
The Agent Collector service resumes processing.
- (O)
Check if JP1/Base is running on the same host as for PFM - Agent for Enterprise Applications. Also check and, if necessary, revise the settings by referencing the chapter that describes operation monitoring linked with the integrated management product (JP1/IM) in the *JP1/Performance Management User's Guide*. If the problem remains unresolved, collect maintenance data and contact the system administrator. For details about how to collect maintenance data, see the chapter that describes error handling procedures in the *JP1/Performance Management User's Guide*.

KAVF14179-W

It failed to issue JP1 system event or Agent event extension, because Memory is insufficient.

The Agent Collector service failed to issue a JP1 system event or an extended agent event due to insufficient memory. The resources required by PFM are insufficient or the system is unstable due to resource leakage in another application.

- (S)
The Agent Collector service resumes processing.
- (O)
Identify the problem and recover the system status. Secure the necessary system resources by re-estimating the required resources as well as by expanding the memory.

KAVF14184-E

An attempt to load the RFC library failed. (file path=*file-path*, reason=*cause*, func=*name-of-API*, error code=*error-code*)

An error occurred while loading the RFC library.

The meanings of the values displayed in the message are as follows:

`file path`: The file path of the RFC library

reason: *cause*; *cause* is one of the following:

- `no such file (s)`: The file or files do not exist.
- `invalid library (ies)`: One or more libraries are not valid.
- `the CRT libraries are not installed`: One or more required CRT libraries are not installed.
- `system error`: A system error occurred.

func: The name of the API that generated the error

error code: The number of the error

If the error was not generated by an API, no values will be set for `func` and `error code`.

(S)

Terminates the Agent Collector service.

(O)

Check the *cause* that is output, take action according to below, and then start the Agent Collector service. If this does not resolve the problem, collect maintenance data and contact the system administrator.

- If *cause* is `no such file (s)`
Check whether an RFC library is stored at the path indicated by *file-path*.
- If *cause* is `invalid library (ies)`
Check whether a valid RFC library is stored at the path indicated by *file-path*.
- If *cause* is `the CRT libraries are not installed`
Check whether the libraries of the Visual C++ redistribution package are installed.
- If *cause* is `system error`
Collect maintenance data, and then contact the system administrator or a support service.

For the version of the RFC library or libraries required, see the *Release Notes*.

For details about how to obtain RFC libraries, see the *Release Notes*.

If this does not resolve the problem, collect data using the `jpcras` command, and then contact the system administrator or a support service.

KAVF14185-E

The RFC library version is invalid. (file path=*file-path*, version=*major-version.minor-version.patch-level*)

The version of the RFC library is not the version required for operation of PFM - Agent for Enterprise Applications.

(S)

Terminates the Agent Collector service.

(O)

Store a valid version of the RFC library at the path indicated by *file-path*, and then re-start the Agent Collector service.

For the version of the RFC library or libraries required for operation of the product, see the *Release Notes*.

For details about how to obtain RFC libraries, see the *Release Notes*.

KAVF14186-E

A timeout occurred during interprocess communication. (timeout seconds=*timeout-time*)

A timeout occurred during interprocess communication.

The following are possible causes of the error:

- The SAP system being monitored is placing a heavy workload on resources and delaying the acquisition of performance data.
- A large volume of performance data was acquired, and a large amount of it is required for the SAP system or PFM - Agent for Enterprise Applications to process it.
- The SAP system is not responding for some other reason.

(S)

When this error occurs during startup processing, Agent Collector service terminates abnormally.

When this error occurs after startup has finished (while operating), the performance data required when the error occurred is not acquired.

Check the KAVF14171-W message output after this message for the performance data that was not acquired.

(O)

Check the system's workload status, the work process usage status, and the SAP system status.

If the problem occurs frequently and the errors are not being resolved, collect maintenance data using the `jpcras` command, and then contact the system administrator or a support service.

KAVF14190-E

Interprocess communication failed (reason=*reason-code*)

Communication between the `jpcMcollect` process and another process failed.

reason=*reason-code*; *reason-code* is one of the following:

- initialization of interprocess communication failed: Initialization of interprocess communication failed.
- shared memory does not exist: The shared memory does not exist.
- corruption of communication data was detected: Corruption of communication data was detected.

(S)

When this error occurs during startup processing, Agent Collector service terminates abnormally.

When this error occurs after startup finished (while operating), performance data required when the error occurred is not acquired.

Check the KAVF14171-W message output after this message for the performance data that was not acquired.

(O)

If the problem occurs frequently and the errors are not resolved, collect maintenance data using the `jpcras` command, and then contact the system administrator or a support service.

KAVF14191-E

An attempt to load the RFC library failed. (file path=*file-path*, reason=*cause*, func=*function-name*)

An error occurred while loading the RFC library.

The meanings of the values displayed in the message are as follows:

- `file path`: File path to the RFC library
- `reason`: The name of API which causes the error
- `func`: The name of the function resulting in error

(S)

Terminates the Agent Collector service.

(O)

Take action according to below, and then start the Agent Collector service. If this does not resolve the problem, collect maintenance data and contact the system administrator.

- Check whether the RFC library exists in the specified by the file path.
- Check whether the library, which is specified by the file path, is appropriate for OS and architecture.
- Check whether the read and execute permissions (`-r-xr-xr-x`) are applied to the RFC library which is specified by the file path.

For the version of the RFC library or libraries required, see the *Release Notes*.

For details about how to obtain RFC libraries, see the *Release Notes*.

KAVF14200-I

Usage:

```
jr3slget [-h application-server-host -s system-number]
[-c client -u user {-p password | -p2 extended password}]
[-l language] [-codepage codepage]]
[-server sap-instance-name]
[-lasttime timestamp-file]
[{-x The-name-of-the-storage-file-in-WRAP1-format |
-xw The-prefix-for-the-storage-files-in-WRAP2-format |
-x2}]
[-cnf environment-parameters-file]
[-help] [-v]
```

This message displays the usage of the `jr3slget` command when the `-help` option has been specified.

(S)

Terminates the command normally.

KAVF14201-I

Usage:

```
jr3alget [-h application-server-host -s system-number]
[-c client -u user {-p password | -p2 extended password}]
[-l language] [-codepage codepage]]
[-c client -u user -p password [-l language] [-codepage codepage]]
[-ms monitor-set-name -mn monitor-name]
```

```
[-lasttime timestamp-file]
[{-x The-name-of-the-storage-file-in-WRAP1-format |
-xw The-prefix-for-the-storage-files-in-WRAP2-format |
-x2}]
[-cnf environment-parameters-file]
[-help] [-v]
```

This message displays the usage of the `jr3alget` command when the `-help` option has been specified.

(S)

Terminates the command normally.

KAVF14210-I

```
The command ended normally.
```

This message indicates that the command has terminated normally. This message is displayed only when the `-v` option was specified in the command.

(S)

Terminates the command with termination code 0.

KAVF14211-E

```
The command ended abnormally. (exit=termination-code)
```

This message indicates that the command has terminated abnormally.

(S)

Terminates the command with the displayed *termination-code*.

(O)

Check the cause message that was displayed before this message.

KAVF14212-I

```
Connected to the SAP system.
```

RFC connection has been established with the SAP system. This message is displayed only when the `-v` option was specified in the command.

(S)

Following this message, the system displays the `KAVF14213-I` and `KAVF14215-I` messages indicating the parameter information used for connection, and then resumes processing.

KAVF14213-I

```
SAP system data: ashost=application-server-host, sysnr=system-number
```

Following the `KAVF14212-I` message during establishment of RFC connection, this message displays the parameters used as the RFC connection information (destination). This message is displayed only when the `-v` option was specified in the command.

(S)

Following the KAVF14212-I message, the system displays the parameter information used for connection establishment.

KAVF14215-I

SAP user data: client=*client*, user=*user*, lang=*language*, codepage=*code-page*

Following the KAVF14212-I message during establishment of RFC connection, this message displays the parameters used as the RFC connection information (logon information). This message is displayed only when the -v option was specified in the command. If the language and code page were omitted, no values are set in lang= and codepage=. This message does not display the password.

(S)

Following the KAVF14212-I message, the system displays the parameter information used for connection establishment.

KAVF14216-I

Logged on to the external interface. (interface=*interface-name*, version=*version*)

The system successfully logged on to the external interface of the SAP system. This message displays the interface name and version of the logon target. This message is displayed only when the -v option was specified in the command.

(S)

Resumes processing.

KAVF14220-E

An error occurred in the RFC API. (*RFC-API-name-resulting-in-error*)

An RFC API call resulted in an error.

(S)

Following this message, the system displays the KAVF14221-E message that provides detailed error information. The system may also display a supplemental message on the errors that can be classified into categories. The system then cancels execution of the command.

(O)

Check any subsequent messages, eliminate the cause of the error, and then re-execute the command.

KAVF14221-E

RFC_ERROR_INFO: code=*return-code*, group=*error-group*, key=*error-key*, message=*error-message*, abapMsgClass=*ABAP-message-class*, abapMsgType=*ABAP-message-type*, abapMsgNumber=*ABAP-message-number*, abapMsgV1=*ABAP-message-details-field-1*, abapMsgV2=*ABAP-message-details-field-2*, abapMsgV3=*ABAP-message-details-field-3*, abapMsgV4=*ABAP-message-details-field-4*

This message displays the details of an RFC API error. This message follows the KAVF14220-E message. The meanings of the values displayed in the message are as follows:

- code: RFC return code (integer)
- group: Integer that identifies the key

- `key`: Code that identifies the error (maximum of 127 bytes)
- `message`: Text that describes the error (might include linefeed codes) (maximum of 511 bytes)
- `abapMsgClass`: The ABAP message class (maximum of 20 bytes)
- `abapMsgType`: The ABAP message type (maximum of 1 byte)
- `abapMsgNumber`: The ABAP message number (maximum of 3 bytes)
- `abapMsgV1`: An ABAP message details field (maximum of 50 bytes of text)
- `abapMsgV2`: An ABAP message details field (maximum of 50 bytes of text)
- `abapMsgV3`: An ABAP message details field (maximum of 50 bytes of text)
- `abapMsgV4`: An ABAP message details field (maximum of 50 bytes of text)

The size of the RFC API error details is the number of bytes not including \0.

These are the member values in the `RFC_ERROR_INFO` structure that stores the RFC API error information. For details about RFC, see the documentation for the SAP system.

(S)

Cancel execution of the command.

(O)

Correct the error and then re-execute the command.

KAVF14222-E

An error occurred in the function module of the SAP system. (*function-module-name*)

The function module (BAPI) of the SAP system returned an error.

(S)

Following this message, the system displays the `KAVF14223-E` or `KAVF14224-E` message that provides detailed error information. The system may also display a supplemental message on the errors that can be classified into categories. The system then cancels execution of the command.

(O)

Check any subsequent messages, eliminate the cause of the error, and then re-execute the command.

KAVF14223-E

`BAPIRET2`: *type=message-type, id=message-class, number=message-number, message=message-text*

When an error is detected in the function module (BAPI), this message is displayed immediately after the `KAVF14222-E` message. The meanings of the values displayed in the message are as follows:

- `type`: One-byte character indicating the severity level of the message (S: normal, E: error, W: warning, I: information, A: forced termination)
- `id`: Message class (maximum of 20 bytes)
- `number`: Error code (maximum of 3 bytes) that identifies the error
- `message`: Text (maximum of 220 bytes) that describes the nature of the error

These are the member values in the `BAPIRET2` structure that stores a BAPI error. For details about BAPI, see the documentation for the SAP system. For details about the specification of the called BAPI, see the documentation for the SAP system's object navigator (SE80), BAPI browser (BAPI) or the SAP system.

(S)

Cancels execution of the command.

(O)

Correct the error and then re-execute the command.

KAVF14224-E

RFC_EXCEPTION: *error-cause-code*

When an error is detected in a function module by an RFC exception, this message is displayed following the KAVF14222-E message.

(S)

Cancels execution of the command.

(O)

Correct the error and then re-execute the command.

KAVF14225-E

Cannot connect to the SAP system.

A communications error occurred while RFC connection with the SAP system was being established. This message immediately follows the KAVF14220-E and KAVF14221-E messages that provide the name of the function resulting in the error and detailed information. Possible causes of this error are as follows:

- The specified RFC connection inventory is invalid (such as the host name cannot be resolved or the specified system number is invalid).
- The SAP system is not active.
- The SAP system cannot accept an RFC request due to heavy workload.
- There is a problem in the network settings.

(S)

Following this message, the system displays the KAVF14227-E and KAVF14229-E messages that provide the parameter information used for connection establishment. The system then cancels execution of the command.

(O)

Check the destination specified as the RFC connection information to re-evaluate the operating status of the SAP system and the network status, correct the error, and then re-execute the command.

KAVF14226-E

Cannot connect to the SAP system, because an attempt to log on failed.

A logon error occurred when RFC connection was being established with the SAP system. This message immediately follows the KAVF14220-E and KAVF14221-E messages that provide the name of the function resulting in the error and detailed information. Possible causes of this error are as follows:

- The specified RFC connection inventory is invalid (such as the specified user does not exist or the specified password is invalid).
- The user has been locked out.
- The user does not have the correct S_RFC authorizations.
- An extended password containing lower-case letters is defined in the SAP system based on SAP NetWeaver 7.0 or later, but the specified connection information (-p option and PASSWD label in the environment parameters file) does not support extended passwords.

(S)

Following this message, the system displays the KAVF14227-E and KAVF14229-E messages that provide the parameter information used for connection establishment. The system then cancels execution of the command.

(O)

Determine the user specified for the RFC connection information and check for undefined information, password expiration, lockout, and authorizations, correct the error, and then re-execute the command.

KAVF14227-E

SAP system data: *ashost=application-server-host, sysnr=system-number*

In the event of an RFC connection error, following the KAVF14225-E or KAVF14226-E message, this message displays the parameters that were used as the RFC connection information (destination).

(S)

Cancels execution of the command.

(O)

Correct the error and then re-execute the command.

KAVF14229-E

SAP user data: *client=client, user=user, lang=language, codepage=code-page*

In the event of an RFC connection error and following output of the KAVF14225-E or KAVF14226-E message, this message displays the parameters that were used as the RFC connection information (logon). If the language and code page were omitted, no values are set in *lang=* and *codepage=*. This message does not display the password.

(S)

Cancels execution of the command.

(O)

Correct the error and then re-execute the command.

KAVF14230-E

Cannot log on to the external interface. (*interface=logon-target-interface-name, version=version*)

A logon request for the external interface of the SAP system was rejected (BAPI error). This message is preceded by the KAVF14222-E and KAVF14223-E messages that provide the name of the function module (BAPI) resulting in the error and detailed information. Possible causes of this error are as follows:

- The connection-target SAP system does not support this interface.
- The user does not have the S_XMI_PROD authorization.

(S)

Cancels execution of the command.

(O)

Make sure that the release and patch level of SAP Basis (SAP WebAS) in the connection-target SAP system meet the requirements. If the `BAPI_XMI_LOGON` function module resulted in an error during authorization checking, grant the `SXMI_PROD` authorization object to the user being used for RFC connection.

KAVF14231-E

The specified server name is invalid. (*specified-SAP-instance-name*)

The SAP instance name specified by one of the following methods is undefined or invalid (BAPI error):

- `-server` option of the `jr3slget` command
- Environment parameters file (SERVER label of the TARGET section)

This message is preceded by the `KAVF14222-E` and `KAVF14223-E` messages that provide the name of the function module (BAPI) resulting in the error and detailed information.

(S)

Cancels execution of the command.

(O)

Check the specified SAP instance name and re-execute the command. You can use transaction code `SM51` to check the SAP instance name. The SAP instance name is usually in the format `host-name_system-ID_system-number`. The SAP instance names are case-sensitive.

KAVF14232-E

The specified monitor set name is invalid. (*specified-monitor-set-name*)

The monitor set name specified by one of the following methods is undefined or invalid (BAPI error):

- `-ms` option of the `jr3alget` command
- Environment parameters file (MONITOR_SET label of the TARGET section)

This message is preceded by the `KAVF14222-E` and `KAVF14223-E` messages that provide the name of the function module (BAPI) resulting in the error and detailed information.

(S)

Cancels execution of the command.

(O)

Check the specified monitor set name and re-execute the command. You can use transaction code `RZ20` to check the monitor set name. The monitor set name may be shown as *monitor set*. The monitor set names are case-sensitive.

KAVF14233-E

The specified monitor name is invalid. (*specified-monitor-name*)

The monitor name specified by one of the following methods is undefined or invalid (BAPI error):

- `-mn` option of the `jr3alget` command

- Environment parameters file (MONITOR label of the TARGET section)

This message is preceded by the KAVF14222-E and KAVF14223-E messages that provide the name of the function module (BAPI) resulting in the error and detailed information.

(S)

Cancels execution of the command.

(O)

Check the specified monitor name and re-execute the command. You can use transaction code RZ20 to check the monitor set name and monitor name. The monitor set name may be shown as *monitor set*. The monitor names are case-sensitive.

KAVF14240-E

The command execution will be terminated because the system resources are insufficient.

Processing cannot continue because of a memory shortage.

(S)

Cancels execution of the command.

(O)

Terminate an unneeded application or expand the memory, and then re-execute the command.

KAVF14241-E

A file or directory cannot be opened. (*name-of-file-or-directory-resulting-in-error*)

An error occurred during file or directory open or creation processing. If a relative path is shown in the message, it is the path from the work directory for the command. If you have specified a different work directory in the environment parameters file, it may be different from the current directory. Possible causes of this error are as follows:

- The file or directory does not exist (when an existing file is opened).
- The user executing the command does not have the permission to open this file or directory.
- There are not enough system resources to create the file or directory.

(S)

Cancels execution of the command.

(O)

Check the permissions of the user executing the command and the status of the indicated path, correct the error, and then re-execute the command.

KAVF14242-E

The available free space is insufficient for extending the file or directory. (*name-of-file-or-directory-resulting-in-error*)

A disk space shortage occurred when the open file or directory space was to be extended. If a relative path is shown in the message, it is the path from the work directory for the command. If you have specified a different work directory in the environment parameters file, it may be different from the current directory. If an access error has occurred on the standard input/output, a null character string is displayed for *name-of-file-or-directory-resulting-in-error*.

(S)

Cancels execution of the command.

(O)

Increase the available space in the indicated file system or change the location where the file is to be created, and then re-execute the command.

KAVF14243-E

An error occurred during the accessing of the file or directory. (*name-of-file-or-directory-resulting-in-error*)

A general access to a file or directory resulted in an I/O error. If a relative path is shown in the message, it is the path from the work directory for the command. If you have specified a different work directory in the environment parameters file, it may be different from the current directory. If an access error has occurred on the standard input/output, a null character string is displayed for *name-of-file-or-directory-resulting-in-error*.

(S)

Cancels execution of the command.

(O)

Check the status of the indicated path, correct the error, and then re-execute the command.

KAVF14244-E

Initialization of the command failed.

Initialization of the command failed.

(S)

Cancels execution of the command.

(O)

Collect maintenance information, and then contact the system administrator or the Support Service.

KAVF14245-E

Installation of the product has not finished correctly.

Installation of the product has not finished correctly.

(S)

Cancels execution of the command.

(O)

Reinstall the product.

KAVF14250-W

A specified environment parameter is invalid. (*section=section-name, label=label-name*)

The value of the environment parameter indicated by *section-name* and *label-name* is invalid in the environment parameters file. Possible causes of this error are as follows:

- The value is too long.
- The value contains an invalid character.

- The specified numeric value is outside the permitted range.

(S)

Ignores the specified value and resumes processing. The command will not terminate abnormally as a result of this warning.

(O)

Re-evaluate the values specified in the environment parameters file. If you do not specify an environment parameters file with the `-cnf` option, the default environment parameters file (`command-name.ini` in the current directory) is referenced.

KAVF14251-E

A required option is missing.

A required option or an option that cannot be omitted due to a required combination of options is missing. For example, if you specify the `-h` option for RFC connection information, you cannot omit the `-s` option.

(S)

Cancels execution of the command.

(O)

Re-evaluate the command syntax and then re-execute the command.

KAVF14253-E

The option value is invalid. (*option*)

The indicated option value is invalid. Possible causes of this error are as follows:

- The value is omitted.
- The value is too long.
- The value contains an invalid character.
- The specified numeric value is outside the permitted range.

(S)

Cancels execution of the command.

(O)

Re-evaluate the command syntax and then re-execute the command.

KAVF14254-E

An option is invalid. (*option*)

The indicated option character string is invalid.

(S)

Cancels execution of the command.

(O)

Re-evaluate the command syntax and then re-execute the command.

KAVF14255-E

Mutually-exclusive options are specified.

Mutually-exclusive options are specified. For example, the `-x` and `-x2` options for specifying the output destination cannot both be specified.

(S)

Cancels execution of the command.

(O)

Re-evaluate the command syntax and then re-execute the command.

KAVF14256-E

An option is duplicated. (*option*)

The indicated option cannot be specified more than once.

(S)

Cancels execution of the command.

(O)

Re-evaluate the command syntax and then re-execute the command.

KAVF14257-E

Mutually exclusive keys or section names are specified as environment parameters.

Mutually exclusive key section names are specified in the environment parameters file. The following is a possible cause of this error:

- `PASSWD` and `PASSWD2` are both specified, but these sections are mutually exclusive for specifying a password.

(S)

Cancels execution of the command.

(O)

Check and, if necessary, revise the settings in the environment parameters file.

KAVF14260-E

The specified RFC connection parameter (destination) is incomplete.

Processing cannot continue because arguments (`-h` and `-s` options) were omitted and the *RFC-connection-information* environment parameters are undefined or invalid in the environment parameters file. If you are omitting the arguments, make sure that the following items are defined correctly in the `CONNECT` section of the environment parameters file:

- Application server host (`ASHOST`)
- System number (`SYSNR`)

(S)

Cancels execution of the command.

(O)

Re-evaluate the values specified in the environment parameters file and then re-execute the command. If the environment parameters file is not specified with the `-cnf` option, the default environment parameters file (`command-name.ini` in the current directory) is used.

KAVF14261-E

The specified RFC connection parameter (logon) is incomplete.

Processing cannot continue because arguments (`-c`, `-u`, and `-p` options) were omitted and the *RFC-connection-information* environment parameters are undefined or invalid in the environment parameters file. If you are omitting the arguments, make sure that the following items are defined correctly in the `CONNECT` section of the environment parameters file:

- Client (`CLIENT`)
- User (`USER`)
- Password (`PASSWD`)

(S)

Cancels execution of the command.

(O)

Check the values specified in the environment parameters file and then re-execute the command. If you do not specify an environment parameters file with the `-cnf` option, the default environment parameters file (`command-name.ini` in the current directory) is referenced.

KAVF14262-E

The specified target is incomplete.

- For the `jr3slget` command:

Processing cannot continue because an argument (`-server`) was omitted and the *target* environment parameter is undefined or invalid in the environment parameters file. If you are omitting the argument, make sure that the following item is defined correctly in the `TARGET` section of the environment parameters file:

- Application server (`SERVER`)
- For the `jr3alget` command:

Processing cannot continue because arguments (`-ms` and `-mn`) were omitted and the *target* environment parameter is undefined or invalid in the environment parameters file. If you are omitting the arguments, make sure that the following items are defined correctly in the `TARGET` section of the environment parameters file:

- Monitor set name (`MONITOR_SET`)
- Monitor name (`MONITOR`)

(S)

Cancels execution of the command.

(O)

Check the values specified in the environment parameters file and then re-execute the command. If you do not specify an environment parameters file with the `-cnf` option, the default environment parameters file (`command-name.ini` in the current directory) is referenced.

KAVF14263-E

The specified output place is incomplete.

Processing cannot continue because the `-x2` option was omitted and the output-target path in the `X2PATH` label of the `EXTRACTFILE` section is undefined or invalid in the environment parameters file.

(S)

Cancels execution of the command.

(O)

Check the values specified in the environment parameters file and then re-execute the command. If you do not specify an environment parameters file with the `-cnf` option, the default environment parameters file (`command-name.ini` in the current directory) is referenced.

KAVF14270-E

The environment parameter settings file cannot be accessed. (*path-name-of-erroneous-environment-parameters-file*)

The environment parameters file specified with the `-cnf` option is not accessible. If a relative path is shown in the message, it is relative to the current directory. Possible causes of this error are as follows:

- The file does not exist.
- The user executing the command does not have the read permissions.

(S)

Cancels execution of the command.

(O)

Check the permissions granted to the user executing the command and the status of the indicated path, correct the error, and then re-execute the command.

KAVF14271-W

The trace file cannot be accessed. (*path-name-of-erroneous-trace-file*)

An error occurred one or more times during a trace file open or write operation. It may be that no maintenance information was collected or that some maintenance information is missing. If the indicated path is a relative path, it is relative to the work directory for the command. If you have specified a different work directory in the environment parameters file, it may be different from the current directory. Possible causes of this error are as follows:

- The file does not exist.
- The user executing the command does not have the read or write permissions.

(S)

Resumes processing. The command will not terminate abnormally as a result of this warning.

(O)

Check the permissions granted to the user executing the command and the status of the indicated path, and then correct the error. You can use the environment parameters file to change the output destination of the trace file.

KAVF14272-E

The work directory cannot be changed. (*work-directory*)

The work directory cannot be changed to the path specified in the environment parameters file (value specified for the WORKDIR label in the COMMAND section). Possible causes of this error are as follows:

- An invalid path was specified.
- The specified value is not a directory.
- The directory does not have the execution (search) permissions.

(S)

Cancels execution of the command.

(O)

Check the path specified in the environment parameters file (value specified for the WORKDIR label in the COMMAND section), correct the error, and then re-execute the command.

KAVF14273-I

The time-stamp file was initialized. (*timestamp-file-name*)

A new timestamp file was created and management information was initialized. This message is displayed the first time the command is executed with the `-lasttime` option specified (when the specified timestamp file does not exist). This message is displayed only when the `-v` option is specified in the command.

(S)

Terminates the command normally.

(O)

Differential information is output the next time the command is executed. Re-execute the command with the same timestamp file specified.

KAVF14274-E

The time-stamp file cannot be updated. (*timestamp-file-name*)

An unexpected error occurred when the timestamp file was updated. Because the system was unable to store the command result, correct differential records may not be reported the next time the command is executed (records may be duplicated in reports).

(S)

Cancels execution of the command.

(O)

Check the status of the path indicated by *timestamp-file-name* and then correct the error.

KAVF14275-I

Number of processing records: *processed-records-count*

This message shows the number of records reported by the command. This message is displayed only when the `-v` option was specified in the command.

(S)

Resumes processing.

KAVF14276-W

The specified output format column value is invalid. (*specified-value*)

The value specified for a `COLUMN` label is invalid in the `FORMAT` section of the environment parameters file.

(S)

Ignores the value of the corresponding column and resumes processing (fewer columns are displayed). This command is not cancelled as a result of this warning.

(O)

Specify a valid field ID in the `COLUMN` label of the `FORMAT` section in the environment parameters file. For details about the field ID, see *Chapter 11. Commands*. If you do not specify an environment parameters file with the `-cnf` option, the default environment parameters file (*command-name.ini* in the current directory) is referenced.

KAVF14277-I

The time-stamp file was updated. (*timestamp-file-name*)

The timestamp file was updated. This message is displayed only when the `-v` option was specified in the command.

(S)

Terminates the command normally.

KAVF14278-E

The time-stamp file format is invalid. (*name-of-erroneous-timestamp-file*)

The file specified with the `-lasttime` option is not a timestamp file. If the indicated file name is a relative path, it is relative to the work directory for the command. If you have specified a different work directory in the environment parameters file, it may be different from the current directory.

(S)

Cancels execution of the command.

(O)

Specify the correct timestamp file and then re-execute the command. If the timestamp file management information has been damaged due to a file access error, delete the timestamp file and re-create it.

KAVF14280-W

System log information was output but it exceeded the size of data writable to a system log information storage file in one collection operation. (*ashost=application-server-host, sysnr=system-number, server=SAP-instance-name, validsize=valid-data-size-in-bytes, datasize=size-extracted-and-output-in-bytes, path=system-log-information-storage-file-path*)

An amount of system log information exceeding *valid-data-size-in-bytes*, which is the maximum size of the system log information storage file, was output during a single collection.

The valid data size is the maximum amount of data that does not result in a loss of data or a delay when monitoring log file traps using a file monitoring product. It is the file size minus the size of data required by the product.

system-log-information-storage-file-path displayed in the message is the `-x` or `-xw` option value specified in the command or the value specified in the `X2PATH` label in the `ECTRACEFILE` section in the environment parameter file if the `-x2` option is specified.

A maximum of two gigabytes minus one byte of data is extracted and output.

(S)

Resumes processing.

(O)

Action to be taken when the message is displayed

- In the SAP system, check the system log information that was output during and following the collection period in which this message was issued to identify all information that was not reported by the file monitoring product's log file traps. If any of the unreported information requires an action, take the appropriate action according to the output system log information.
- If a `WRAP1` format was being monitored by JP1/Base's log file traps, restart JP1/Base's log file traps.

Action to be taken during re-evaluation

- Re-evaluate the size of system log information storage file (value of the `SIZE` label in the `EXTRACTFILE` section in the environment parameter file) based on *size-extracted-and-output-in-bytes* and *valid-data-size-in-bytes* displayed in the message. Be sure that the file is larger than *size-extracted-and-output-in-bytes* and no more than the valid size of the data that was written. A value of *size-extracted-and-output-in-bytes* minus *valid-data-size-in-bytes* is how much more space is needed.
- If you output storage files in the `WRAP1` format, consider using the `WRAP2` format that enables multiple files to be output.

KAVF14281-W

CCMS alert information was output but it exceeded the size of data writable to a CCMS alert information storage file in one collection operation. (*ashost=application-server-host, sysnr=system-number, monitorset=monitor-set-name, monitor=monitor-name, validsize=valid-data-size-in-bytes, datasize=size-extracted-and-output-in-bytes, path=CCMS-Alert-Information-storage-file-path*)

An amount of CCMS Alert Information exceeding *valid-data-size-in-bytes*, which is the maximum size of CCMS Alert Information storage file, was output during a single collection.

The valid data size is the maximum size of data that does not result in a loss of data or a delay when monitoring log file traps using a file monitoring product. It is the file size minus the size of data required by the product.

CCMS-Alert-Information-storage-file-path displayed in the message is the `-x` or `-xw` option value specified in the command or the value specified in the `X2PATH` label in the `ECTRACEFILE` section in the environment parameter file if the `-x2` option is specified.

A maximum of two gigabytes minus one byte of data is extracted and output.

(S)

Resumes processing.

(O)

Action to be taken when the message is displayed

- In the SAP system, check the CCMS Alert Information that was output during and following the collection period in which this message was issued to identify all information that was not reported by the file monitoring

product's log file traps. If any of the unreported information requires an action, take the appropriate action according to the stored CCMS Alert Information.

- If the WRAP1 format was being monitored by JP1/Base's log file traps, restart JP1/Base's log file traps.

Action to be taken during re-evaluation

- Re-evaluate the size of CCMS Alert Information storage file (value of the SIZE label in the EXTRACTFILE section in the environment parameter file) based on *size-extracted-and-output-in-bytes* and *valid-data-size-in-bytes* displayed in the message so that the file is larger than *size-extracted-and-output-in-bytes* and no more than the valid size of the data that was written. A value of *size-extracted-and-output-in-bytes* minus *valid-data-size-in-bytes* is how much more space is needed.
- If you output storage files in the WRAP1 format, consider using the WRAP2 format that enables multiple files to be output.

KAVF14285-E

An attempt to convert the character code failed. (source character code=*character-encoding-before-conversion*, destination character code=*character-encoding-after-conversion*)

An attempt to convert a character encoding failed.

(S)

Discontinues command execution (abnormal end).

(O)

Investigate whether values specified in arguments or in the environment parameters file contain characters outside the Shift JIS range (excluding private-use characters, platform-dependent characters, and level 3 or level 4 kanji), and then re-execute the command.

If you do not specify an environment parameters file with the `-cnf` option, the default environment parameters file (*command-name.ini* in the current directory) is referenced.

KAVF14286-E

An attempt to load the RFC library failed. (file path=*file-path*, reason=*cause*, func=*name-of-API*, error code=*error-code*)

An error occurred while loading the RFC library.

The meanings of the values displayed in the message are as follows:

`file path`: The file path of the RFC library

`reason`: *cause*; *cause* is one of the following:

- `no such file(s)`: The file or files do not exist.
- `invalid library(ies)`: One or more libraries are not valid.
- `the CRT libraries are not installed`: One or more required CRT libraries are not installed.
- `system error`: A system error occurred.

`func`: The name of the API that generated the error

`error code`: The number of the error

If the error was not generated by an API, no values will be set for `func` and `error code`.

(S)

Discontinues command execution (abnormal termination).

(O)

Check the *cause* that is output, take action according to below, and then re-execute the command. If this does not resolve the problem, collect maintenance data and contact the system administrator.

- If *cause* is `no such file(s)`
Check whether an RFC library is stored at the path indicated by *file-path*.
- If *cause* is `invalid library(ies)`
Check whether a valid RFC library is stored at the path indicated by *file-path*.
- If *cause* is `the CRT libraries are not installed`
Check whether the libraries of the Visual C++ redistribution package are installed.
- If *cause* is `system error`
Collect maintenance data, and then contact the system administrator or a support service.

For the version of the RFC library or libraries required, see the *Release Notes*.

For details about how to obtain RFC libraries, see the *Release Notes*.

If this does not resolve the problem, collect data using the `jpcras` command, and then contact the system administrator or a support service.

KAVF14287-E

The RFC library version is invalid. (file path=*file-path*, version=*major-version.minor-version.patch-level*)

The version of the RFC library is not the version required for operation of PFM - Agent for Enterprise Applications.

(S)

Discontinues command execution (abnormal termination).

(O)

Store a valid version of RFC library at the path indicated by *file-path*, and then re-execute the command.

For the version of the RFC library or libraries required for operation of the product, see the *Release Notes*.

For details about how to obtain RFC libraries, see the *Release Notes*.

KAVF14288-E

An attempt to load the RFC library failed. (file path=*file-path*, reason=*cause*, func=*function-name*)

An error occurred while loading the RFC library.

The meanings of the values displayed in the message are as follows:

- `file path`: File path to the RFC library
- `reason`: The name of API which causes the error
- `func`: The name of the function resulting in error

(S)

Discontinues command execution (abnormal termination).

(O)

Take action according to below, and then re-execute the command. If this does not resolve the problem, collect maintenance data and contact the system administrator.

- Check whether the RFC library exists in the specified by the file path.
- Check whether the library, which is specified by the file path, is appropriate for OS and architecture.
- Check whether the read and execute permissions (-r-xr-xr-x) are applied to the RFC library which is specified by the file path.

For the version of the RFC library or libraries required, see the *Release Notes*.

For details about how to obtain RFC libraries, see the *Release Notes*.

KAVF14289-E

A prerequisite module was not found.

A prerequisite module was not found in the system.

(S)

Discontinues command execution (abnormal termination).

(O)

Take action according to below, and then re-execute the command. If this does not resolve the problem, collect maintenance data and contact the system administrator.

- Check whether the prerequisite OS package exists in the system.
Refer to the *Release Notes* for prerequisite software.

KAVF14290-E

Preparation for character code conversion failed.

The system failed to open the character code conversion table at communication with the SAP system.

(S)

Discontinues command execution (abnormal termination).

(O)

Ensure the kernel parameter that has sufficient number of files to be opened by the system and process and try again. If this does not resolve the problem, collect maintenance data and contact the system administrator.

13

Error Handling Procedures

This chapter explains how to handle errors that may occur while you are using Performance Management products. This chapter is concerned principally with handling errors relating to a PFM - Agent. For details about error handling for the entire Performance Management system, see the chapter that describes error handling procedures in the *JP1/Performance Management Planning and Configuration Guide*.

13.1 Error handling procedures

This section describes the procedures for handling errors that occur while you are using Performance Management products.

Check the event

Check the following:

- Event when the error occurred
- Contents of any messages that have been displayed
- Log information (such as common message log)

For details about the messages and how to respond to each message, see *Chapter 12. Messages*. For details about the log information that is output by the Performance Management products, see *13.3 Log information to be collected during troubleshooting*.

Collect data

Collect data to determine the cause of the error. For details about how to collect the necessary data, see *13.4 Data to be collected during troubleshooting* and *13.5 How to collect data during troubleshooting*.

Determine the cause

Use the collected data to determine the cause and extent of the error, as well as the range of its consequences.

13.2 Troubleshooting

This section explains how to conduct troubleshooting while you are using Performance Management products. If an error occurs while you are using a Performance Management product, you should first check to see if any of the events described in this section have occurred.

The following table lists the principal errors that may occur while you are using a Performance Management product.

Table 13–1: Errors

Classification	Nature of problem	Section
Setting up or starting service	<ul style="list-style-type: none">• A Performance Management program service does not start.• It takes a long time for a service to start once startup is requested.• Immediately after a Performance Management program service is stopped, another program service is started, but communication does not function correctly.• After the message <code>The disk capacity is insufficient</code> is displayed, the Master Store or Agent Store service stops.• The Agent Collector or Remote Monitor Collector service did not start.	13.2.1
Executing commands	<ul style="list-style-type: none">• When the <code>jpctool service list</code> command is executed, the names of services that are not operating are output.• When the <code>jpctool db dump</code> command is executed, data other than the specified Store data is output.	13.2.2
Report definitions	<ul style="list-style-type: none">• There is a time period that is not displayed in historical reports.	13.2.3
Alarm definitions	<ul style="list-style-type: none">• The program defined for action execution does not function correctly.• An alarm event is not displayed.• An alarm threshold was exceeded, but the alarm icon remains in green in the Alarm Status window in the Agents tree.	13.2.4
Collecting and managing performance data	<ul style="list-style-type: none">• The size of the PFM - Agent's Store database does not become smaller even though the data retention period was shortened.• The message <code>KAVE00128-E Illegal data was detected in the Store database or KAVE00163-E. The database type is illegal</code> was output to the common message log and the startup of Store database fails.• The message <code>KAVF14173-W The performance data cannot be reported. (record-ID[.field-name])</code> is output to the common message log.	13.2.5
File monitoring	<ul style="list-style-type: none">• JP1 events are not issued successfully (when JP1/Base's log file traps are used).• The <code>KAVF14280-W</code> message is output to the Windows event log (in Windows) or to syslog (in Linux).• The <code>KAVF14281-W</code> message is output to the Windows event log (in Windows) or to syslog (in Linux).	13.2.6

13.2.1 Troubleshooting related to setup and service startup

Handle errors related to setup or service startup as described below.

(1) A Performance Management program service does not start

Causes and solutions:

- PFM - Manager is not active.
If PFM - Manager and PFM - Agent are both on the same host, the PFM - Agent services cannot start if PFM - Manager is not active. Determine whether the PFM - Manager service has started, and start it if it has not. For details about how to start services, see the chapter that describes startup and termination of Performance Management in the *JPI/Performance Management User's Guide*.
- The same port number is set for multiple Performance Management program services.
When the same port number is set for multiple Performance Management program services, none of the Performance Management program services can be started. The default is for the system to assign port numbers automatically, in which case there will not be any duplicated port numbers. If you specified specific port numbers for any Performance Management program services during Performance Management setup, check the specified port numbers. If you specified the same port number for more than one Performance Management program service, specify different port numbers. For details about how to set port numbers, see the chapter that describes installation and setup in the *JPI/Performance Management Planning and Configuration Guide*.
- There is an error in the settings for the Store database directory.
If any of the following directories is inaccessible or does not exist, the Agent Store service cannot start; check the specified directory names and settings and correct any errors:
 - Store database directory
 - Store database backup directory
 - Store database export directory
 - Store database partial backup directory (applicable to Store version 2.0)
 - Store database import directory (applicable to Store version 2.0)If you specify any of these directories for multiple Agent Store services, the Agent Store services cannot start; check the specified directory names and settings and correct any errors.
- The host name of the machine was changed using a non-permitted procedure.
For details about how to rename a host on a machine, see the chapter that describes installation and setup in the *JPI/Performance Management Planning and Configuration Guide*. If you use a nonstandard procedure to rename a host, the Performance Management program services may not start.
- An error occurred on the service control manager.
If you execute the `jpcspm start` command in Windows, the error message `An error occurred in the Windows service control manager` might be displayed and service startup might fail. If this occurs, re-execute the `jpcspm start` command. If this event occurs frequently, edit the `jpccomm.ini` file to change the retry interval and retry count for service startup processing during execution of the `jpcspm start` command.
For details about how to change the retry interval and retry count, see the chapter that describes startup and termination of Performance Management in the *JPI/Performance Management User's Guide*.
- The SAP system is inactive.
If you specified `DELAYCONNECT=N` during construction of the instance environment and the SAP system is inactive when connection is to be established with the SAP system, the Agent Collector service cannot start. Make sure that the SAP system is running. To start the Agent Collector service whether the SAP system is active, specify `DELAYCONNECT=Y`.
- The library has not been set up correctly.

If the library is not set up after PFM - Agent for Enterprise Applications is installed, or if the setup procedure is not followed correctly, the Agent Collector service will not start. When this happens, message KAVF14184-E is output. Make sure that the library is set up correctly based on the description in [3.1.4 Library application procedure](#).

(2) It takes a long time for a service to start once startup is requested

It may take some time for a service to actually start once you execute the `jpcspm start` command or when you start a service by choosing the **Service** icon. If this is due to one of the following reasons, the time required to start the service will be reduced when the service is started subsequently:

- If you use the standalone mode, it might take time for a service to start.
- When you start a service by restarting the system without specifying the setting for automatically stopping services during system shutdown, the indexes of the Store database may be rebuilt. If this happens, it may take extra time for services to start.
- During initial startup after a new Agent has been added, the indexes of the Store database are rebuilt. This may cause the service to take longer to start up.
- When the Store service is unable to perform normal termination processing for a reason such as a power interrupt, it may take extra time for services to start because the indexes of the Store database are rebuilt during the restart.

(3) Immediately after a Performance Management program service is stopped, another program service is started, but communication does not function correctly

Immediately after a Performance Management program service is stopped, another program service may be started that uses the same port that the stopped service was using. In such a case, communication may not function correctly. You can use either of the following techniques to avoid this problem:

- Fix the port numbers for the Performance Management program services.
Assign a fixed port number to each Performance Management program service. For details about how to set port numbers, see the chapter that describes installation and setup in the *JPI/Performance Management Planning and Configuration Guide*.
- Set the `TCP_TIMEWAIT` value.
Set the `TCP_TIMEWAIT` value that specifies a connection wait time.
In Windows, use the default connection wait time. The default value is as follows:
 - In Windows: 2 minutesIn Linux, you cannot change the connection wait time setting from the default of 60 seconds. If this problem occurs in Linux, use the technique to fix the port numbers of the Performance Management program services.

(4) After the message "The disk capacity is insufficient" is displayed, the Master Store or Agent Store service stops

If there is not enough free space on the disk used by the Store database, data storage into the Store database is interrupted. In such a case, the message `The disk capacity is insufficient` is displayed and then the Master Store or Agent Store service stops.

When this message is displayed, take one of the following actions:

- Provide sufficient disk space

Determine the required disk capacity for the Store database and change the Store database storage location to a disk with sufficient capacity. For details about how to estimate the disk space required for the Store database, see the *Release Notes* of PFM - Agent for Enterprise Applications. For details on how to change the storage location of the Store database, see [3.6.1 Changing the performance data storage location](#).

- Change the data retention condition for the Store database

Change the data retention condition for the Store database and adjust its maximum data capacity. For details about how to change the data retention condition for the Store database, see the chapter that describes management of operation monitoring data in the *JPI/Performance Management User's Guide*.

If the Master Store or Agent Store service does not start even after you have taken these actions, an unrecoverable logical conflict has occurred in the Store database. In such a case, restore the Store database from a backup and then start the Master Store or Agent Store service. If no backup is available, initialize the Store database and then start the Master Store or Agent Store service. To initialize the Store database, you must delete all the following files in the storage directory for the Store database:

- Files with extension `.DB`
- Files with extension `.IDX`

For details about the Store database storage directory, see [3.6.1 Changing the performance data storage location](#).

(5) The Agent Collector or Remote Monitor Collector service does not start

Suppose the OS of a PFM - Agent host or a PFM - RM host is Windows, PFM - Agent or PFM - RM starts, and the Agent Collector service or the Remote Monitor Collector service fails to start. When that occurs and Windows restarts, the following message might be output to a Windows event log.

- `service-name service hung on starting.`

This event occurred because Windows Service Control Manager timed out. This event is prone to occur when communication loads on PFM - Manager are heavy and it takes too much time to receive a response from PFM - Manager. This event occurs when all the following conditions are satisfied:

- Communication loads on PFM - Manager are heavy.
An example is that many PFM - Agent or PFM - RM startup processes are being executed concurrently.
- For each of the PFM - Agent or PFM - RM services, the startup type is set to **Auto** in the Windows Services applet.
- The OS is restarted.

To avoid this event, take one of the following actions:

- If services are being started when the OS restarts, use the `jpccspm start` command, not Windows Service Control Manager.
- Reduce the time required for starting PFM - Agent or PFM - RM by specifying the setting described below on the PFM - Agent or PFM - RM host.

This setting reduces the time required for reconnection processing if an attempt to connect to PFM - Manager fails when the PFM - Agent or PFM - RM services are started. Note, that, by reducing the reconnection time, the PFM - Agent or PFM - RM services more likely start in stand-alone mode.

To reduce the time required for starting PFM - Agent or PFM - RM, change the `NS Init Retry Count` label from `NS Init Retry Count =2` to `NS Init Retry Count =1` in **Agent Collector x Section[#]** and **Agent Store x Section[#]** in the startup information file (`jpccomm.ini`).

x indicates the product ID of PFM - Agent or PFM - RM. For details about the product IDs, see the list of IDs provided in the appendix of each PFM - Agent or PFM - RM manual. If multiple PFM - Agents or PFM - RMs are installed on the same host, specify the `NS Init Retry Count` label for each product ID.

The startup information file (`jpccomm.ini`) is stored at the following location:

If the PFM - Agent or PFM - RM host is a physical host:

`installation-folder\jpccomm.ini`

If the PFM - Agent or PFM - RM host is a logical host:

`environment-directory#\jp1pc\jpccomm.ini`

Indicates the directory on the shared disk that was specified when the logical host was created.

13.2.2 Troubleshooting related to command execution

Handle errors related to execution of Performance Management commands as described below.

(1) When the `jpctool service list` command is executed, the names of services not operating are output

Possible causes and solutions:

- A Performance Management program was uninstalled without its service information being deleted
Service information for a Performance Management program remains in the database even after the program has been uninstalled. Execute the `jpctool service delete` command to delete the service information. For details about how to delete service information, see the chapter that describes installation and setup in the *JPI/Performance Management Planning and Configuration Guide*.
- The host name of the machine was changed without deleting Performance Management program service information
If the host name of a machine was changed without deleting Performance Management program service information, the service information corresponding to service IDs that were associated with the previous host name remains in the database that the Master Manager service manages. Execute the `jpctool service delete` command to delete the service information. For details about how to delete service information and how to rename hosts, see the chapter that describes installation and setup in the *JPI/Performance Management Planning and Configuration Guide*.

(2) When the `jpctool db dump` command is executed, data other than the specified Store data is output

Specifying the same export file name for the same Master Store or Agent Store service in multiple executions of the `jpctool db dump` command causes the initial output results to be overwritten by the subsequent output results. Specify a different export file name each time you execute the `jpctool db dump` command for the same Master Store or Agent Store service. For details about how to export Store data, see the chapter that describes management of operation monitoring data in the *JPI/Performance Management User's Guide*.

(3) The `jr3alget` or `jr3slget` command terminates abnormally

If the library is not set up after PFM - Agent for Enterprise Applications is installed, or if the setup procedure is not followed correctly, the `jr3alget` and `jr3slget` commands will terminate abnormally. If this happens, message

KAVF14286-E is output. Make sure that the library is set up correctly based on the description in [3.1.4 Library application procedure](#).

13.2.3 Troubleshooting related to report definitions

This subsection describes how to handle problems that are related to report definitions for Performance Management.

(1) There is a time period that is not displayed in historical reports

If the current time of the system on which PFM - Agent is installed is changed to some future time, historical information from the period between the old time and the new time is not stored.

13.2.4 Troubleshooting related to alarm definitions

This section describes the procedures for handling problems in the alarm definitions of Performance Management.

(1) The program defined for action execution does not function correctly

The possible cause and action to be taken are as follows:

- PFM - Manager or the Action Handler service at the target host is not active
If PFM - Manager or the Action Handler service at the target host is inactive, actions cannot be executed. To execute actions, make sure that PFM - Manager and the Action Handler service at the target host are active.

(2) An alarm event is not displayed

The possible cause and action to be taken are as follows:

- PFM - Manager is not active.
If PFM - Manager is inactive, the system cannot issue alarm events from PFM - Agents correctly. To monitor alarm events, make sure that PFM - Manager is active.

(3) An alarm threshold is exceeded, but the alarm icon remains in green in Display Alarm Status in the Agents tree

The possible causes, and actions to take, are as follows:

- Alarm tables using the Japanese language are bound in an environment where the LANG environment variables are not set to Japanese on both PFM - Manager and PFM - Agent hosts.
In this case, alarms using the Japanese language are not evaluated successfully. Set the LANG environment variables to Japanese on both PFM - Manager and PFM - Agent hosts. To determine the LANG environment variable settings, check the common message logs to see whether the most recent service start messages are issued in Japanese or English.
If the PFM - Manager host is running in an English-language environment and its language setting is changed to Japanese, the existing alarm definitions become garbled and can no longer be deleted. Therefore, be sure to perform the following procedure:
 1. If you need alarm tables using definitions in the Japanese language, export all of them from PFM - Web Console.
Not that the `jpctool alarm export` command cannot be used to export the tables.

2. Delete all alarm tables using definitions in the Japanese language.
3. Stop PFM - Manager service.
4. Change the LANG environment variable setting to Japanese on the PFM - Manager host.
5. Start PFM - Manager service.
6. If you have exported the alarm tables in step 1, use PFM - Web Console or the `jpctool alarm import` command to import the alarm tables.

For other notes about an environment where both Japanese and English languages are used, see the chapter describing notes about environments in which the Japanese and English languages are intermixed in the *JPI/Performance Management Planning and Configuration Guide*.

13.2.5 Troubleshooting related to collection and management of performance data

Handle errors related to collection and management of Performance Management performance data as described below.

(1) The size of the PFM - Agent's Store database does not become smaller even though the data retention period was shortened

If the size of Store database version 1.0 has reached its maximum, shortening the data retention period does not reduce the file size. In such a case, shorten the retention period, back up the Store database, and then restore the database.

For details about how to specify the data retention period, see the chapter that describes management of operation monitoring data in the *JPI/Performance Management User's Guide*. For details about how to back up and restore the Store database, see the chapter that describes backup and restore processing in the *JPI/Performance Management User's Guide*.

(2) A messages, such as KAVE00128-E or KAVE00163-E is output to the common message log and the startup of Store database fails

Data integrity of the Store database might have been lost due to an unexpected stoppage of a PFM service or a forced shutdown such as power outage to the machine. Take the following actions:

- If the Store database has been backed up, restore the Store database.
- If the Store database has not been backed up, terminate the PFM system containing the Store service that cannot be started (the Master Store, Agent Store, or Remote Monitor Store service), initialize the Store database, and then restart the target PFM service that was stopped.

To initialize the Store database, delete all the files listed below from the Store database storage directory.

If StoreVR is 1.0:

- Files with extension `.DB`
- Files with extension `.IDX`

If StoreVR is 2.0:

- Files with extension `.DB`
- Files with extension `.IDX`

Delete all files under the `STPI`, `STPD`, and `STPL` directories.

(Retain the STPI, STPD, and STPL directories.)

The default Store database storage directory is as follows:

Store database storage directory for performance data

For details, see [3.6.1 Changing the performance data storage location](#).

Store database storage directory for event data

If PFM - Agent for Enterprise Applications is not in a cluster environment:

- Windows
installation-folder\agtm\store\instance-name
- Linux
/opt/jplpc/agtm/store/instance-name/

If PFM - Agent for Enterprise Applications is in a cluster environment:

- Windows
environment-directory\agtm\store\instance-name
- Linux
environment-directory/jplpc/agtm/store/instance-name/

(3) The message KAVF14173-W "The performance data cannot be reported. (record-ID[field-name])" is output to the common message log

If connection dialogue instance of the SAP system does not have an MTE name for the acquisition, the field of some records is zero because this field does not exist in the connection-target dialog instance. This warning message is output even for a program that is not monitored.

If your SAP system employs an ASCS instance configuration, ignore this message.

13.2.6 Troubleshooting related to the log monitoring program

This subsection describes how to handle problems that are related to the log monitoring programs.

(1) JP1 events are not issued successfully in JP1/Base's log file traps

If JP1/Base's log file traps are used to monitor a system log information or CCMS Alert Information storage file in the WRAP1 format, JP1 events might not be sent successfully when the storage file wraps around. If this event occurs, take the following actions:

Action to be taken when the message is displayed

- In the SAP system, check the system log information or CCMS Alert Information output during the time period in which JP1 events were not issued successfully to identify all information that was not reported in the file monitoring product's log file traps. If any of the unreported information requires an action, take the appropriate action according to the output system log information or CCMS Alert Information.
- Restart JP1/Base's log file traps.

Action to be taken during re-evaluation

- Check and, if necessary, revise the size of the storage file.

Re-evaluate the size of system log information or CCMS Alert Information storage file (value of the `SIZE` label in the `EXTRACTFILE` section in the environment parameter file) based on *size-extracted-and-output* and *valid-data-size* displayed in the `KAVF14280-W` or `KAVF14281-W` message output to the Windows event log (in Windows) or syslog (in Linux) so that the file is larger than *size-extracted-and-output* and no more than the valid size of data that was written. The value of *size-extracted-and-output* minus *valid-data-size* is how much more space is needed.

- Change the format of storage file from `WRAP1` to `WRAP2`.

Before you change the storage file format, terminate any executing command or stop record collection, and then stop JP1/Base's log file traps. After that, manually delete the storage files, management files, and timestamp files.

(2) The KAVF14280-W message is output to the Windows event log (in Windows) or to syslog (in Linux)

If the `KAVF14280-W` message is output to the Windows event log (in Windows) or syslog (in Linux), take the following action:

Action to be taken when the message is displayed

- In the SAP system, check the system log information output during and following the collection period in which this message was output to identify all information that was not reported in the file monitoring product's log file traps. If any of the unreported information requires an action, take the appropriate action according to the output system log information.
- If the `WRAP1`-format file was being monitored by JP1/Base's log file traps, restart JP1/Base's log file traps.

Action to be taken during re-evaluation

- Re-evaluate the size of system log information storage file (value of the `SIZE` label in the `EXTRACTFILE` section in the environment parameter file) based on *size-extracted-and-output* and *valid-data-size* displayed in the message so that the file is larger than *size-extracted-and-output* and no more than the valid size of data that was written. The value of *size-extracted-and-output* minus *valid-data-size* is how much more space is needed.
- If you output storage files in the `WRAP1` format, consider using the `WRAP2` format that enables multiple files to be output.

(3) The KAVF14281-W message is output to the Windows event log (in Windows) or to syslog (in Linux)

If the `KAVF14281-W` message is output to the Windows event log (in Windows) or syslog (in Linux), take the following action:

Action to be taken when the message is displayed

- In the SAP system, check the CCMS Alert Information output during and following the collection period in which this message was output to identify all information that was not reported in the file monitoring product's log file traps. If any of the unreported information requires an action, take the appropriate action according to the output CCMS Alert Information.
- If the `WRAP1`-format file was being monitored by JP1/Base's log file traps, restart JP1/Base's log file traps.

Action to be taken during re-evaluation

- Re-evaluate the size of CCMS Alert Information storage file (value of the `SIZE` label in the `EXTRACTFILE` section in the environment parameter file) based on *size-extracted-and-output* and *valid-data-size* displayed in the message so that the file is larger than *size-extracted-and-output* and no more than the valid size of data that was written. A value of *size-extracted-and-output* minus *valid-data-size* is how much more space is needed.
- If you output storage files in the `WRAP1` format, consider using the `WRAP2` format that enables multiple files to be output.

13.2.7 Troubleshooting related to the remote monitoring function

This subsection describes how to troubleshoot for problems related to remote monitoring.

- During the extraction of system log information and CCMS alert information, only the information that arose after the previous record collection time is extracted. When there is a difference between the system clocks of the host on which PFM - Agent for Enterprise Applications is installed and the SAP system, the phenomena described in the following table occur.

Table 13–2: System clock delay status and the phenomena associated with it

Function	If the SAP system clock is ahead of the system clock of PFM - Agent for Enterprise Applications	If the SAP system clock is behind the system clock of PFM - Agent for Enterprise Applications
Extraction of system log information	Information is extracted.	The error message <code>KAVF14222-E</code> is output, and an attempt to extract system log information fails.
Extraction of CCMS alert information		CCMS alert information is not correctly extracted.

When any of these phenomena occurs, set a collection base time.

- When a time delay in the SAP system exceeds the time period set with `SHIFTEXTRACTTIME`, the following phenomena can occur:
 - The message `KAVF14222-E` is output.
 - CCMS alert information is not correctly extracted.

If these phenomena occur, measure the time delay in the SAP system and set `SHIFTEXTRACTTIME` with sufficient margin to accommodate the time delay. Use a function provided by the OS or other means to measure the time delay in the SAP system. For details, see the manual on the OS.

- If the host on which PFM - Agent for Enterprise Applications is running and the SAP system use different time zones, executing the system log information extraction function without setting `SAPTIMEZONEOFFSET` can cause one of the following phenomena due to the difference in local time arising from the different time zones used by the hosts:

If the local time based on the time zone used by the host on which PFM - Agent for Enterprise Applications is running is ahead of the local time of the SAP system

The error message `KAVF14222-E` is output, and any attempt to extract system log information always ends in failure.

If the local time based on the time zone used by the SAP system is ahead of the local time of the host on which PFM - Agent for Enterprise Applications is running

Only system log information from an older time period is extracted, which means that the latest system log information reflecting what is currently occurring can never be extracted.

13.2.8 Troubleshooting related to other problems

You should check the existing circumstances when other errors occur. If a message is output, read its contents. For details about the log information that is output by Performance Management, see *13.3 Log information to be collected during troubleshooting*.

If you cannot resolve an error by taking any of the steps described from Section *13.2.1 Troubleshooting related to setup and service startup* through Section *13.2.6 Troubleshooting related to the log monitoring program*, or if an error occurs that is not described in these sections, collect data needed to investigate the error and contact the system administrator.

For details about the data you should collect and how to collect it, see *13.4 Data to be collected during troubleshooting* and *13.5 How to collect data during troubleshooting*.

13.3 Log information to be collected during troubleshooting

When an error occurs with Performance Management, you should check the log information and investigate the problem. The following four types of log information are output during operation of Performance Management:

- System log
- Common message log
- Operation status log
- Trace log

This section describes the four types of log information and the log options that can be set for each type.

13.3.1 Type of log information to be collected during troubleshooting

(1) System log

The system log contains log information that reports the system status and errors that occurred. Performance Management outputs the system log to the following log file:

- Windows
Event log file
- Linux
syslog file

For details about the output formats, see the chapter that describes log information in the manual *JPI/Performance Management Reference*.

Notes about logical host operation

In addition to the system log for Performance Management, you need the log information for the cluster software in order to check information such as Performance Management control by the cluster software.

(2) Common message log

The common message log contains log information that reports the system status and errors that have occurred. The information output to this log is more detailed than the system log information. For details about the common message log's output destination file name and file size, see [13.3.2 Lists of log files and directories to be collected during troubleshooting](#). For details about the output format, see the chapter that describes log information in the manual *JPI/Performance Management Reference*.

Notes about logical host operation

For Performance Management under logical host operation, the common message log is output to the shared disk. Because log files on the shared disk are inherited together with the system during failover, messages continue to be recorded in the same log file.

(3) Operation status log

The operation status log is the log information that is output by PFM - Web Console. For details about the name and size of the operation status log file, see the chapter that describes error handling procedures in the *JPI/Performance*

Management User's Guide. For details about the output format, see the chapter that describes log information in the manual *JPI/Performance Management Reference*.

(4) Trace log

Whenever an error occurs, the trace log contains log information that is needed to investigate the cause of the error or to determine the processing time required by each process.

The trace log is output to a log file for the particular Performance Management program service.

Notes about logical host operation

For Performance Management under logical host operation, the trace log is output to the shared disk. Because log files on the shared disk are inherited together with the system during failover, messages continue to be recorded in the same log file.

13.3.2 Lists of log files and directories to be collected during troubleshooting

This section describes the log information that is output from Performance Management. For details about the name and size of the file to which the operation status log information is output, see the chapter that describes error handling procedures in the *JPI/Performance Management User's Guide*.

(1) Common message log

For details about the common message log, see the chapter that describes details on log information in the *JPI/Performance Management User's Guide*.

(2) Trace log

This section describes the trace log, which is one of the types of log information for Performance Management. The tables below list, for each OS, the service names or control names that are the output sources of PFM - Agent trace logs, as well as the names of the storage folders.

Table 13–3: Names of the trace log storage folders (Windows)

Type of log information	Output source	Folder name
Trace log	Agent Collector service	<i>installation-folder</i> \agtm\agent\ <i>instance-name</i> \log\
	Agent Store service	<i>installation-folder</i> \agtm\store\ <i>instance-name</i> \log\
Trace log (for logical host operation)	Agent Collector	<i>environment-directory</i> #\jp1pc\agtm\agent\ <i>instance-name</i> \log\ \
	Agent Store	<i>environment-directory</i> #\jp1pc\agtm\store\ <i>instance-name</i> \log\ \

#

The environment directory is on the shared disk that was specified when the logical host was created.

Table 13–4: Names of the trace log storage directories (Linux)

Type of log information	Output source	Directory name
Trace log	Agent Collector service	<code>/opt/jp1pc/agtm/agent/instance-name/log/</code>
	Agent Store service	<code>/opt/jp1pc/agtm/store/instance-name/log/</code>
Trace log (for logical host operation)	Agent Collector	<code>environment-directory[#]/jp1pc/agtm/agent/instance-name/log/</code>
	Agent Store	<code>environment-directory[#]/jp1pc/agtm/store/instance-name/log/</code>

#

The environment directory is on the shared disk that was specified when the logical host was created.

13.4 Data to be collected during troubleshooting

If the appropriate action described in *13.2 Troubleshooting* is not successful in correcting the error, you should collect necessary data and contact the system administrator to determine the cause of the error. This section describes the data that should be collected in the event of an error.

Performance Management provides commands for collecting the needed data in batch mode. Use the `jpcras` command to collect PFM - Agent data. The following tables indicate the data that can be collected by the `jpcras` command.

Note

The data collected by the `jpcras` command depends on the options you specify when you execute the command. For details about the command's options and the data that can be collected, see the chapter that describes commands in the *JP1/Performance Management User's Guide*.

Notes about logical host operation

The following notes apply to logical host operation:

- During logical host operation, Performance Management log information is stored on the shared disk. If the shared disk is placed online (Windows) or mounted (Linux), you can use the `jpcras` command to also collect the log information on the shared disk in batch mode.
- To evaluate problems during failover, you need the information existing before and after the failover. This means that you need the information about both executing and standby systems.

To examine Performance Management for logical host operation, information about the cluster software is necessary. Because Performance Management for logical host operation is started and terminated from the cluster software, the behavior of the cluster software must be compared with the behavior of Performance Management.

13.4.1 Data to be collected during troubleshooting in a Windows environment

(1) Log information about the OS

The following OS-related information must be collected:

Type of information	Overview	Default file name	Collected by the <code>jpcras</code> command?
System log	Windows event log	N/A	Y
Process information	List of processes	N/A	Y
System file	hosts file	<code>system-folder\system32\drivers\etc\hosts</code>	Y
	services file	<code>system-folder\system32\drivers\etc\services</code>	Y
OS information	System information	N/A	Y
	Network status	N/A	Y
	Host name	N/A	Y
Dump information	Problem reports and solutions log file	<code>user-mode-process-dump-output-folder\program-name.process-ID.dmp</code> Example: <code>jpcagtm.exe.2420.dmp</code>	N

Legend:

Y: Can be collected.

N: Cannot be collected.

N/A: Not applicable.

#

If your setup provides for output of log files to a different folder, make sure that you collect the data from the correct folder.

(2) Information about Performance Management

You should collect information about Performance Management, as listed below. In the case of a network error, you should also collect applicable files from the connection-destination machine.

Type of information	Overview	Default file name	Collected by the jpcras command?
Common message log	Message log output from Performance Management (sequential file method)	<i>installation-folder</i> \log\jpclog{01 02}#1	Y
	Message log output from Performance Management (wraparound file method)	<i>installation-folder</i> \log\jpclogw{01 02}#1	Y
Common message log (for logical host operation)	Message log output from Performance Management for logical host operation (sequential file method)	<i>environment-directory</i> #2\jplpc\log\jpclog{01 02}#1	Y
	Message log output from Performance Management for logical host operation (wraparound file method)	<i>environment-directory</i> #2\jplpc\log\jpclogw{01 02}#1	Y
Configuration information	Each configuration information file	N/A	Y
	Output results of the <code>jpctool service list</code> command	N/A	Y
Version information	Product version	N/A	Y
	Historical information	N/A	Y
Database information	Agent Store service	<ul style="list-style-type: none"> For Store version 1.0 <i>installation-folder</i>\agtm\store\<i>instance-name</i>*.DB <i>installation-folder</i>\agtm\store\<i>instance-name</i>*.IDX For Store version 2.0 <i>installation-folder</i>\agtm\store\<i>instance-name</i>\STPD\<i>installation-folder</i>\agtm\store\<i>instance-name</i>\STPI\ The following files under the above folders: 	Y

Type of information	Overview	Default file name	Collected by the jpcras command?
Database information	Agent Store service	*.DB *.IDX	Y
Database information (for logical host operation)	Agent Store service for logical host operation	<ul style="list-style-type: none"> For Store version 1.0 <i>environment-directory</i>^{#2}\jplpc\agtm\store\instance-name*.DB <i>environment-directory</i>^{#2}\jplpc\agtm\store\instance-name*.IDX For Store version 2.0 <i>environment-directory</i>^{#2}\jplpc\agtm\store\instance-name\STPD\ <i>environment-directory</i>^{#2}\jplpc\agtm\store\instance-name\STPI\ The following files under the above folders: *.DB *.IDX 	Y
Trace log	Trace information for each Performance Management program service	N/A ^{#3}	Y
Install log ^{#4}	Message log during installation	All files under the %windir%\TEMP\HCDINST folder	N
Command information	Environment parameters file	<i>installation-folder</i> \agtm\agent\instance-name\jr3alget.ini <i>installation-folder</i> \agtm\agent\instance-name\jr3slget.ini	Y
	Trace information	N/A	Y
	Timestamp file	N/A	Y
	Storage file	<ul style="list-style-type: none"> WRAP1 <i>installation-folder</i>\agtm\agent\instance-name\log\ALERT <i>installation-folder</i>\agtm\agent\instance-name\log\SYSLOG WRAP2 <i>installation-folder</i>\agtm\agent\instance-name\log\ALERT^{#5} <i>installation-folder</i>\agtm\agent\instance-name\log\SYSLOG^{#5} 	Y ^{#6}
	Management file	<i>installation-folder</i> \agtm\agent\instance-name\log\ALERT ofs <i>installation-folder</i> \agtm\agent\instance-name\log\SYSLOG ofs	Y
Command information (for logical host operation)	Environment parameters file	<i>environment-directory</i> ^{#2} \jplpc\agtm\agent\instance-name\jr3alget.ini <i>environment-directory</i> ^{#2} \jplpc\agtm\agent\instance-name\jr3slget.ini	Y
	Trace information	N/A	Y
	Timestamp file	N/A	Y

Type of information	Overview	Default file name	Collected by the jpcras command?
Command information (for logical host operation)	Storage file	<ul style="list-style-type: none"> WRAP1 <code>environment-directory#2\jplpc\agtm\agent\instance-name\log\ALERT</code> <code>environment-directory#2\jplpc\agtm\agent\instance-name\log\SYSLOG</code> WRAP2 <code>environment-directory#2\jplpc\agtm\agent\instance-name\log\ALERTn#5</code> <code>environment-directory#2\jplpc\agtm\agent\instance-name\log\SYSLOGn#5</code> 	Y#6
	Management file	<code>environment-directory#2\jplpc\agtm\agent\instance-name\log\ALERT.ofs</code> <code>environment-directory#2\jplpc\agtm\agent\instance-name\log\SYSLOG.ofs</code>	Y

Legend:

- Y: Can be collected.
- N: Cannot be collected.
- N/A: Not applicable.

#1

For details about how to output log information to log files, see the chapter that describes detection of Performance Management failures in the *JPI/Performance Management User's Guide*.

#2

The environment directory is on the shared disk that was specified when the logical host was created.

#3

For details about the trace log storage folder, see *13.3.2 Lists of log files and directories to be collected during troubleshooting*.

#4

Collect this log information if installation fails.

#5

n indicates a number.

#6

If the default storage location is changed, the `jpcras` command cannot collect the information. Collect the information manually.

For details about the location of storage file, see the `EXTRACTFILE` section in *5.3.2 Settings* and the `EXTRACTFILE` section in *6.3.2 Settings*.

(3) Information about the SAP system

You must collect the following information about the SAP system which is being monitored.

Table 13–5: Information about the SAP system

Type of information	Data to be collected
System log	<p>Data collected by using transaction SM21 in the SAP front-end software with the following conditions:</p> <ul style="list-style-type: none"> • User: Not specified • Transaction code: Not specified. • SAP process: Not specified. • Error class: All messages • Start date and time, end date and time: Time period in which the error occurred <p>For details about the system log, see the manual and Help for the SAP system.</p>
XMI log	<p>Data collected by using transaction RZ15 in the SAP front-end software with the following conditions:</p> <ul style="list-style-type: none"> • Interface: * • Object: * • Session ID: * • External user: * • Period: Time period in which the error occurred <p>For details about the XMI log, see the manual and Help for the SAP system.</p>
Release and patch information	<ul style="list-style-type: none"> • Hardcopy of a screenshot of the window that is displayed when Status is selected from the SAP front-end software's System menu • Hardcopy of screenshots of the following windows that are displayed from the above window: <ul style="list-style-type: none"> System: Status window System: Component Information window System: Kernel Information window
Developer trace	<p>Developer traces in the SAP system that are collected if an error occurs during execution of a command provided by PFM - Agent for Enterprise Applications or in the Agent Collector service (<code>dev_w*</code>, <code>dev_rfc*</code>, and <code>dev_rd</code> files that are collected by using transaction ST11 in the SAP front-end software)</p>

Legend:

*: A wildcard indicating a string of any one or more characters

(4) Operation information

You should collect the following information about the operation being performed when the error occurred:

- Details of the operation
- Time the error occurred
- Machine configuration (the OS version, host name, and PFM - Manager and PFM - Agent configuration, and so on.)
- Whether the problem is replicable
- Performance Management user name used during logon, if the user has logged on from PFM - View

(5) Error information on screen displays

You should obtain printouts of the following:

- The active screen when the application error occurred
- The error message dialog box (including the contents of detail information if displayed)
- The Command Prompt window or the Administrator Console window, if the error occurred during command execution

(6) User dump

Collect a user dump when a Performance Management process is terminated because of an application error.

(7) Collecting a problem report

Collect a problem report when a Performance Management process is terminated because of an application error.

(8) Other information

You should also collect the following information:

- The contents of **System** and **Application** in the Event Viewer window of Windows
- The contents of **System Information**, which is displayed by choosing **Accessories** and then **System Tools**
- The command arguments that were specified, if the error occurred during command execution

13.4.2 Data to be collected during troubleshooting in a Linux environment

(1) Log information about the OS

The following OS-related information must be collected:

Type of information	Overview	Default file name	Collected by the jpcras command?
System log	syslog	/var/log/messages*	Y#
Process information	List of processes	N/A	Y
System file	hosts file	/etc/hosts	Y
	services file	/etc/services	Y
OS information	Patch information	N/A	Y
	Kernel information	N/A	Y
	Version information	N/A	Y
	Network status	N/A	Y
	Environment variable	N/A	Y
	Host name	N/A	Y
Dump information	core file	N/A	Y

Legend:

Y: Can be collected.

N/A: Not applicable.

#

The information cannot be collected if the system is set to output the information to a location other than the default path and file. In such a case, collect the information manually.

(2) Information about Performance Management

You need to collect information about Performance Management, as listed below. In the case of a network error, you also need to collect applicable files from the connection-destination machine.

Type of information	Overview	Default file name	Collected by the jpcras command?
Common message log	Message log output from Performance Management (sequential file method)	/opt/jp1pc/log/jpclog{01 02}#1	Y
	Message log output from Performance Management (wraparound file method)	/opt/jp1pc/log/jpclogw{01 02}#1	Y
Common message log (for logical host operation) Configuration information	Message log output from Performance Management for logical host operation (sequential file method)	<i>environment-directory</i> #2/jp1pc/log/jpclog{01 02}#1	Y
	Message log output from Performance Management for logical host operation (wraparound file method)	<i>environment-directory</i> #2/jp1pc/log/jpclogw{01 02}#1	Y
	Each configuration information file	N/A	Y
	Output results of the jpc tool service list command	N/A	Y
Version information	Product version	N/A	Y
	Historical information	N/A	Y
Database information	Agent Store service	<ul style="list-style-type: none"> For Store version 1.0 /opt/jp1pc/agtm/store/<i>instance-name</i>/*.DB /opt/jp1pc/agtm/store/<i>instance-name</i>/*.IDX For Store version 2.0 /opt/jp1pc/agtm/store/<i>instance-name</i>/STPD/ /opt/jp1pc/agtm/store/<i>instance-name</i>/STPI/ The following files under the above directories: *.DB *.IDX 	Y
Database information (for	Agent Store service for logical host operation	<ul style="list-style-type: none"> For Store version 1.0 	Y

Type of information	Overview	Default file name	Collected by the jpcras command?
logical host operation)	Agent Store service for logical host operation	<p><i>environment-directory</i>^{#2}/<i>jp1pc/agtm/store/instance-name</i>/*.DB</p> <p><i>environment-directory</i>^{#2}/<i>jp1pc/agtm/store/instance-name</i>/*.IDX</p> <ul style="list-style-type: none"> For Store version 2.0 <p><i>environment-directory</i>^{#2}/<i>jp1pc/agtm/store/instance-name</i>/STPD/</p> <p><i>environment-directory</i>^{#2}/<i>jp1pc/agtm/store/instance-name</i>/STPI/</p> <p>The following files under the above directories:</p> <ul style="list-style-type: none"> *.DB *.IDX 	Y
Trace log	Trace information for each Performance Management program service	N/A ^{#3}	Y
Install log ^{#4}	Standard log of Hitachi Program Product Installer	<p>/etc/.hitachi/.hitachi.log</p> <p>/etc/.hitachi/.hitachi.log{01 02 03 04 05}</p> <p>/etc/.hitachi/.install.log</p> <p>/etc/.hitachi/.install.log{01 02 03 04 05}</p>	N
Command information	Environment parameters file	<p>/opt/jp1pc/agtm/agent/<i>instance-name</i>/jr3alget.ini</p> <p>/opt/jp1pc/agtm/agent/<i>instance-name</i>/jr3slget.ini</p>	Y
	Trace information	N/A	Y
	Timestamp file	N/A	Y
	Storage file	<ul style="list-style-type: none"> WRAP1 <p>/opt/jp1pc/agtm/agent/<i>instance-name</i>/log/ALERT</p> <p>/opt/jp1pc/agtm/agent/<i>instance-name</i>/log/SYSLOG</p> <ul style="list-style-type: none"> WRAP2 <p>/opt/jp1pc/agtm/agent/<i>instance-name</i>/log/ALERTⁿ^{#5}</p> <p>/opt/jp1pc/agtm/agent/<i>instance-name</i>/log/SYSLOGⁿ^{#5}</p>	Y ^{#6}
Management file	<p>/opt/jp1pc/agtm/agent/<i>instance-name</i>/log/ALERT.ofs</p> <p>/opt/jp1pc/agtm/agent/<i>instance-name</i>/log/SYSLOG.ofs</p>	Y	
Command information (for logical host operation)	Environment parameters file	<p><i>environment-directory</i>^{#2}/<i>jp1pc/agtm/agent/instance-name</i>/jr3alget.ini</p> <p><i>environment-directory</i>^{#2}/<i>jp1pc/agtm/agent/instance-name</i>/jr3slget.ini</p>	Y
	Trace information	N/A	Y
	Timestamp file	N/A	Y
	Storage file	<ul style="list-style-type: none"> WRAP1 <p><i>environment-directory</i>^{#2}/<i>jp1pc/agtm/agent/instance-name</i>/log/ALERT</p>	Y ^{#6}

Type of information	Overview	Default file name	Collected by the jpcras command?
Command information (for logical host operation)	Storage file	<code>environment-directory#2/jp1pc/agtm/agent/instance-name/log/SYSLOG</code> <ul style="list-style-type: none"> WRAP2 <code>environment-directory#2/jp1pc/agtm/agent/instance-name/log/ALERTn#5</code> <code>environment-directory#2/jp1pc/agtm/agent/instance-name/log/SYSLOGn#5</code>	Y#6
	Management file	<code>environment-directory#2/jp1pc/agtm/agent/instance-name/log/ALERT.ofs</code> <code>environment-directory#2/jp1pc/agtm/agent/instance-name/log/SYSLOG.ofs</code>	Y

Legend:

- Y: Can be collected.
- N: Cannot be collected.
- N/A: Not applicable.

#1

For details about how to output log information to log files, see the chapter that describes detection of Performance Management failures in the *JP1/Performance Management User's Guide*.

#2

The environment directory is on the shared disk that was specified when the logical host was created.

#3

For details about the trace log storage directory, see *13.3.2 Lists of log files and directories to be collected during troubleshooting*.

#4

Collect this log information if installation fails.

#5

n indicates a number.

#6

If the default storage location is changed, the `jpcras` command cannot collect the information. Collect the information manually.

For details about the location of storage file, see the `EXTRACTFILE` section in *5.3.2 Settings* and the `EXTRACTFILE` section in *6.3.2 Settings*.

(3) Information about the SAP system

You must collect the following information about the SAP system which is being monitored.

Table 13–6: Information about the SAP system

Type of information	Data to be collected
System log	Data collected by using transaction SM21 in the SAP front-end software with the following conditions: <ul style="list-style-type: none"> User: Not specified. Transaction code: Not specified.

Type of information	Data to be collected
System log	<ul style="list-style-type: none"> • SAP process: Not specified. • Error class: All messages • Start date and time, end date and time: Time period in which the error occurred <p>For details about the system log, see the manual and Help for the SAP system.</p>
XMI log	<p>Data collected by using transaction RZ15 in the SAP front-end software with the following conditions:</p> <ul style="list-style-type: none"> • Interface: * • Object: * • Session ID: * • External user: * • Period: Time period in which the error occurred <p>For details about the XMI log, see the manual and Help for the SAP system.</p>
Release and patch information	<ul style="list-style-type: none"> • Hardcopy of a screenshot of the window that is displayed when Status is selected from the SAP front-end software's System menu • Hardcopy of screenshots of the following windows that are displayed from the above window: <ul style="list-style-type: none"> System: Status window System: Component Information window System: Kernel Information window
Developer trace	<p>Developer traces in the SAP system that are collected if an error occurs during execution of a command provided by PFM - Agent for Enterprise Applications or in the Agent Collector service (<code>dev_w*</code>, <code>dev_rfc*</code>, and <code>dev_rd</code> files that are collected by using transaction ST11 in the SAP front-end software)</p>

Legend:

*: A wildcard indicating a string of any one or more characters

(4) Operation information

You should collect the following information about the operation being performed when the error occurred:

- Details of the operation
- Time the error occurred
- Machine configuration (the OS version, host name, and PFM - Manager and PFM - Agent configuration, and so on.)
- Whether the problem is replicable
- Performance Management user name used during logon, if the user has logged on from PFM - View

(5) Error information

You should obtain the following error information:

- Messages output to the console, if the error occurred during command execution

(6) Other information

You should also collect the following information:

- Command arguments that were specified, if the error occurred during command execution

13.5 How to collect data during troubleshooting

This section explains how to collect data in the event of an error.

13.5.1 How to collect data during troubleshooting in a Windows environment

(1) Collecting dump information

To collect dump information:

1. Open the Task Manager.
2. Choose the **Processes** tab.
3. Right-click the name of the process whose dump is to be collected, and then choose **Create Dump File**.

A dump file is stored in the following folder:

```
system-drive\Users\user-name\AppData\Local\Temp
```

4. Collect the dump file from the folder in step 3.

If you have changed the environment variable settings in such a manner that dump files are output to a different folder, collect the dump file from the appropriate folder.

(2) Executing the data collection command

Use the `jpcras` command to collect data needed to determine the cause of an error (note that an OS user with the Administrators permission must execute the procedure described below).

To execute the data collection command:

1. Log on to the host where the service subject to this data collection is installed.
2. At the command prompt, execute the following command to enable the extension function of the command interpreter:

```
cmd /E:ON
```

3. Specify in the `jpcras` command the data to be collected and the storage folder for the data, and then execute the command.

The following `jpcras` command stores in the `c:\tmp\jpc\agt` folder all information other than database and dump information:

```
jpcras c:\tmp\jpc\agt all
```

When you execute the `jpcras` command, the `jpctool service list -id * -host *` command is executed internally in order to obtain a list of PFM services and check their activity status. If there is a firewall between the host where the command is executed and the host for the Performance Management system, or if the system configuration is large, it might take time to execute the `jpctool service list -id * -host *` command.

If desirable, you can reduce the command execution time by suppressing execution of the `jpctool service list -id * -host *` command. To do this, specify 1 in the `JPC_COLCTRLNOHOST` environment variable.

For details about the `jpccras` command, see the chapter that describes commands in the manual *JPI/Performance Management Reference*.

Note

If the user account control function (UAC) of the OS is enabled, a dialog box for user account control may appear during command execution. If this occurs, click the **Continue** button to proceed with data collection. Clicking the **Cancel** button stops data collection.

(3) Executing the data collection command (for logical host operation)

Performance Management information for logical host information is on the shared disk and must be collected in both executing and standby systems.

You use the `jpccras` command to collect information needed to check the cause of a problem. This subsection describes how to execute the data collection command. This procedure must be executed by an OS user with the `Administrators` permission.

To execute the data collection command for logical host operation:

1. Place the shared disk online.

Information about the logical host is stored on the shared disk. At the executing node, make sure that the shared disk is online and then collect the information.

2. In both executing and standby systems, execute the `jpccras` command specifying the information to be collected and its storage folder.

The following `jpccras` command stores in the `c:\tmp\jpc\agt` folder all information other than database and dump information:

```
jpccras c:\tmp\jpc\agt all
```

Executing the `jpccras` command without the `lhost` argument specified collects all the Performance Management information on the physical and logical hosts at the node. If there is a Performance Management in the logical host environment, the log files on the shared disk are acquired.

If the `jpccras` command is executed at a node where the shared disk is offline, files cannot be acquired from the shared disk, but the command terminates normally without resulting in an error.

Note

Execute the data collection command at both executing and standby nodes to collect information. To evaluate an event before and after failover, you need the information for both executing and standby systems.

For details about the `jpccras` command, see the chapter that describes commands in the manual *JPI/Performance Management Reference*.

3. Collect information about the cluster software.

This information is needed to determine whether the problem occurred in the cluster software or Performance Management. Collect the information that provides details about control requests, such as startup and termination of Performance Management from the cluster software, and their results.

(4) If the system log information and CCMS Alert Information is not stored in the default locations

Manually collect the storage and management files from the new storage location.

(5) Collecting the Windows event log

In the Windows Event Viewer window, output the Windows event log to a file.

(6) Collecting information about the SAP system

Collect information about the SAP system which is being monitored.

For details about the data to be collected, see *13.4.1 (3) Information about the SAP system*.

(7) Checking information about the operation

You should check and save information about the operation being performed when the error occurred; the following is the information that you should check and save:

- Details of the operation
- Time the error occurred
- Machine configuration (the OS version, host name, and PFM - Manager and PFM - Agent configuration, and so on)
- Whether the problem is replicable
- Performance Management user name used during logon, if the user has logged on from PFM - View

(8) Collecting error information on screen displays

You should obtain printouts of the following:

- The active screen when the application error occurred
- The error message dialog box
Also print a copy of any detailed information.
- The Command Prompt window or the Administrator Console window, if the error occurred during command execution

To print the Command Prompt window, specify the following settings in the Command Prompt Properties window:

- **Edit options** on the **Options** page
Select **Simple edit mode**.
- **Layout** page
For **Window buffer size**, set **Height** to 500.

(9) Other information

- The command arguments that were specified, if the error occurred during command execution
- The contents of **System Information**, which is displayed by choosing **Accessories** and then **System Tools**
- The contents of **System** and **Application** in **Windows Logs** located in the left-hand pane of the Event Viewer window of Windows

13.5.2 How to collect data during troubleshooting in a Linux environment

(1) Executing the data collection command

Use the `jpccras` command to collect the data needed to determine the cause of an error (note that the procedure described below must be executed by an OS user with the `root` permission).

To execute the data collection command:

1. Log on to the host where the service subject to this data collection is installed.
2. Specify in the `jpccras` command the data to be collected and the storage directory for the data, and then execute the command.

The following `jpccras` command stores all the available information in the `/tmp/jpc/agt` directory:

```
jpccras /tmp/jpc/agt all all
```

The data collected by the data collection command can be stored in the specified directory in a compressed format by using either the `tar` or the `compress` command. Example file name:

```
jpccrasYYMMDD.tar.Z
```

The date is added at the location indicated by `YYMMDD`.

When you execute the `jpccras` command, the `jpctool service list -id * -host *` command is executed internally in order to obtain a list of PFM services and check their activity status. If there is a firewall between the host where the command is executed and the host for the Performance Management system, or if the system configuration is large, it might take time to execute the `jpctool service list -id * -host *` command. If desirable, you can reduce the command execution time by suppressing execution of the `jpctool service list -id * -host *` command. To do this, specify `1` in the `JPC_COLCTRLNOHOST` environment variable.

For details about the `jpccras` command, see the chapter that describes commands in the manual *JPI/Performance Management Reference*.

(2) Executing the data collection command (for logical host operation)

Performance Management information for logical host information is on the shared disk and must be collected in both executing and standby systems.

You use the `jpccras` command to collect information needed to check the cause of a problem. This subsection describes how to execute the data collection command. This procedure must be executed by an OS user with the `root` user permission.

To execute the data collection command for logical host operation:

1. Mount the shared disk.
Information about the logical host is stored on the shared disk. At the executing node, make sure that the shared disk is mounted and then collect the information.
2. In both executing and standby systems, execute the `jpccras` command specifying the information to be collected and its storage directory.

The following example stores all the information collectible by the `jpccras` command in the `/tmp/jpc/agt` directory:

```
jpccras /tmp/jpc/agt all all
```

The information collected by the data collection command is stored in the specified directory in the compressed format specified by the `tar` and `compress` commands. The file name is as follows:

```
jpccrasYYMMDD.tar.Z
```

`YYMMDD` is replaced with the date (year, month, date).

Executing the `jpccras` command without the `lhost` argument specified collects all the Performance Management information on the physical and logical hosts at the node. If there is a Performance Management in the logical host environment, the log files on the shared disk are acquired.

If the `jpccras` command is executed at a node where the shared disk is not mounted, files cannot be acquired from the shared disk, but the command terminates normally without resulting in an error.

Note

Execute the data collection command at both executing and standby nodes to collect information. To evaluate an event before and after failover, you need the information for both executing and standby systems.

For details about the `jpccras` command, see the chapter that describes commands in the manual *JPI/Performance Management Reference*.

3. Collect information about the cluster software.

This information is needed to determine whether the problem occurred in the cluster software or Performance Management. Collect the information that provides details about control requests, such as startup and termination of Performance Management from the cluster software, and their results.

(3) If the system log information and CCMS Alert Information are not stored in the default locations

Manually collect the storage and management files from the new storage location.

(4) Collecting information about the SAP system

Collect information about the SAP system which is being monitored.

For details about the data to be collected, see *13.4.2 (3) Information about the SAP system*.

(5) Checking information about the operation

You should check and save information about the operation being performed when the error occurred; the following is the information that you should check and save:

- Details of the operation
- Time the error occurred
- Machine configuration (the OS version, host name, and PFM - Manager and PFM - Agent configuration, and so on.)
- Whether the problem is replicable
- Performance Management user name used during logon, if the user has logged on from PFM - View

(6) Collecting error information

You should collect the following error information:

- Messages output to the console, if the error occurred during command execution

(7) Other information

You should also collect the following information:

- Command arguments that were specified, if the error occurred during command execution

13.6 Detecting problems within Performance Management

Performance Management provides a health check function for detecting Performance Management problems. The health check function monitors the operating status of the monitoring agent as well as the host on which the monitoring agent is running, and displays the monitoring results on PFM - Web Console as a change in the status of the monitoring agent.

The automatic PFM service restart function enables you to automatically restart the PFM service if the PFM service has stopped abnormally for some reason and to periodically restart the PFM service.

To monitor the operating status of the monitoring agent by the health check function and automatically restart the PFM service by the automatic PFM service restart function, you use the status management function that enables you to check the detailed status of Performance Management services. Therefore, the version of the target monitoring agent must support the status management function and the status management function must be enabled. There are no prerequisite conditions for monitoring the operating status of the host.

You can also detect Performance Management problems by using JP1/Base (integrated system monitoring product) to monitor the Performance Management log files. The system administrator can then detect a problem, identify its cause, and take appropriate action for recovery.

For details about detection of Performance Management problems, see the chapter that describes detection of Performance Management problems in the *JP1/Performance Management User's Guide*.

13.7 Performance Management system error recovery

If the Performance Management server fails, you must use backup files to restore the normal status that existed before the system error occurred.

For details about how to restore the system to the status it was in before a system error occurred, see the chapter that describes troubleshooting in the *JP1/Performance Management User's Guide*.

Appendixes

A. System Estimates Before Configuration

Before configuring a system that will use PFM - Agent for Enterprise Applications, we recommend that you first estimate the performance of the computer to be used, to ensure that the computer is capable of running PFM - Agent for Enterprise Applications.

A.1 Memory requirements

The memory requirements vary depending on the setup conditions and on the conditions under which PFM - Agent for Enterprise Applications will be used. For details about the formulas used to estimate the memory requirements, see the *Release Notes* of PFM - Agent for Enterprise Applications.

A.2 Disk space requirements

The required disk space varies depending on the number of records that store performance data. Estimation of disk space requirements involves both the estimation of disk space requirements for the entire system and for the Store database (Store version 1.0 or 2.0). For details about the formulas used to estimate the disk space requirements, see the *Release Notes* of PFM - Agent for Enterprise Applications.

A.3 Disk space requirements for cluster use

The disk space requirements for cluster use are the same as for non-cluster use. For details about the disk space requirements, see the *Release Notes* of PFM - Agent for Enterprise Applications.

B. Kernel Parameters

PFM - Agent for Enterprise Applications does not require adjustment of kernel parameters.

For details about how to adjust the kernel parameters for using the Store database version 2.0 in a Linux environment, see the appendix that lists the kernel parameters in the *JP1/Performance Management Planning and Configuration Guide*.

C. List of Identifiers

To operate PFM - Agent for Enterprise Applications or to extract performance data from the Store database of PFM - Agent for Enterprise Applications, identifiers are required so that the system can identify PFM - Agent for Enterprise Applications. The following table shows the identifiers of PFM - Agent for Enterprise Applications.

Table C–1: Identifiers of PFM - Agent for Enterprise Applications

Use	Name	Identifier	Description
Commands, etc.	Product ID	M	The product ID is part of the service ID. The service ID is required for commands that perform operations, such as checking the system configuration of the Performance Management series and backing up performance data. For details about the service ID, see the naming rules in the appendix in the <i>JP1/Performance Management Planning and Configuration Guide</i> .
	Service key	agtm or EAP	This identifier is needed in order to use commands to start and stop PFM - Agent for Enterprise Applications. For details about the service key, see the appendix in the <i>JP1/Performance Management Planning and Configuration Guide</i> .
Help	Help ID	pcam	This is the identifier for PFM - Agent for Enterprise Applications help.

D. List of Processes

This appendix lists the processes of PFM - Agent for Enterprise Applications.

For details about the processes of PFM - Manager, PFM - Web Console, and PFM - Base, see the appendix in the manual *JP1/Performance Management Reference*.

The following table lists the processes of PFM - Agent for Enterprise Applications. The value in parentheses following each process name is the number of processes that can run concurrently.

Note

The number of processes that can be running is the same as for PFM - Agent on a logical host.

Table D–1: Processes of PFM - Agent for Enterprise Applications (Windows)

Process name (processes-count)	Function
<code>jpcagtm.exe (n)</code> #1	Process of the Agent Collector service. One <code>jpcagtm</code> process is started for each instance of PFM - Agent for Enterprise Applications.
<code>jpcMcollect.exe (n)</code> #2	Execution process that performs communications with SAP. There is one of these processes for each <code>jpcagtm</code> process.
<code>jpcsto.exe (n)</code> #1	Process of the Agent Store service. One <code>jpcsto</code> process is started for each instance of PFM - Agent for Enterprise Applications.
<code>jr3alget.exe (1)</code> #2	Process for collecting CCMS alert information
<code>jr3slget.exe (1)</code> #2	Process for collecting system log information
<code>stpqlpr.exe (1)</code> #3	Process for backup/export of the Store database

#1

n indicates the number of processes.

#2

This is a child process of the `jpcagtm` process.

#3

This is a child process of the `jpcsto` process.

Table D–2: Processes of PFM - Agent for Enterprise Applications (Linux)

Process name (processes-count)	Function
<code>jpcagtm (n)</code> #1	Process of the Agent Collector service. One <code>jpcagtm</code> process is started for each instance of PFM - Agent for Enterprise Applications.
<code>jpcMcollect (n)</code> #2	Execution process that performs communications with SAP. There is one of these processes for each <code>jpcagtm</code> process.
<code>jpcsto (n)</code> #1	Process of the Agent Store service. One <code>jpcsto</code> process is started for each instance of PFM - Agent for Enterprise Applications.
<code>jr3alget.exe (1)</code> #2	Process for collecting CCMS alert information
<code>jr3slget.exe (1)</code> #2	Process for collecting system log information
<code>stpqlpr (1)</code> #3	Process for backup/export of the Store database.

#1

n indicates the number of processes.

#2

This is a child process of the `jpcautm` process.

#3

This is a child process of the `jpcasto` process.

E. List of Port Numbers

This appendix lists the port numbers of Performance Management.

For details about the port numbers for PFM - Manager and PFM - Base and for details about the firewall passage directions, see the appendix in the manual *JPI/Performance Management Reference*.

You can change a port number to match your system environment. For details about how to change a port number, see the chapter that describes installation and setup in the *JPI/Performance Management Planning and Configuration Guide*. The TCP/IP protocol is used.

Note

Performance Management supports static NAT (Basic NAT) that performs 1-to-1 address conversion. It does not support dynamic NAT or NAT (IP Masquerade, NAT+) that includes a port conversion function.

E.1 Port numbers of Performance Management

The following table shows the port numbers used by Performance Management:

Table E–1: Port numbers used by Performance Management

Port number	Parameter	Service name	Usage
--#1	jplpcstom[<i>nnn</i>] ^{#2}	Agent Store service	Used to record performance data and acquire historical reports.
--#1	jplpcagtm[<i>nnn</i>] ^{#2}	Agent Collector service	Used to bind alarms and acquire real-time reports.

#1

Each time the service is restarted, port numbers that are not being used by the system are assigned automatically.

#2

When multiple instances of the service are created, a sequential number (*nnn*) is appended to the second and subsequent instances. The first instance does not have a sequential number.

E.2 Firewall passage directions

If there is a firewall between PFM - Manager and PFM - Agent for Enterprise Applications, you must set fixed port numbers for all services of PFM - Manager and the PFM - Agent. Set the port numbers so that communications can pass through the firewall for all services.

For details, see the description about the directions in which data passes through a firewall in the manual *JPI/Performance Management Reference*.

To use the remote monitoring function, you have to set up the port number of the SAP system to be monitored in a way that allows it to pass through the firewall.

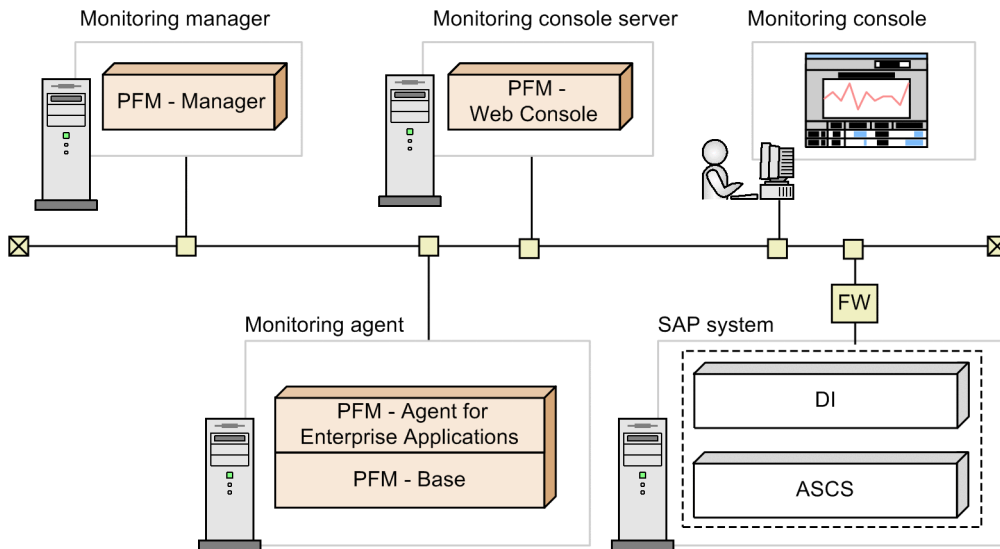

Legend:

- FW : Firewall
- : Program provided by Performance Management
- : Required program
- ASCS : ABAP Central Services instance
- DI : Dialog instance

Table E-2: Firewall passage direction and supported firewalls

Service name	Port number	Direction of communication ^{#1#2}	Supported firewalls
<code>sapgwⁿⁿ</code> ^{#3}	<code>33ⁿⁿ</code> ^{#3} / <code>tcp</code>	PFM - Agent for Enterprise Applications → SAP system	Packet filtering type, and NAT (static mode) type address conversion
Any (Default: <code>sapdp99</code>) ^{#4}	<code>Any</code> / <code>tcp</code> (Default: <code>3299</code> / <code>tcp</code>)	PFM - Agent for Enterprise Applications → SAP system	Packet filtering type, and NAT (static mode) type address conversion

Legend:

→ : The direction in which communication (connection) begins

#1

After communication (connection) begins, sending and receiving are performed on the established session. Specify the settings so that a reception to the established session can also penetrate a firewall.

#2

When communication (connection) begins, the connection-source host uses a free port number assigned by the OS as the receiving port. Therefore, specify the settings so that any port number can penetrate a firewall as the receiving port.

#3

`nn` denotes the system number representing the SAP system at the connection destination.

#4

If you are using the SAProuter to connect to the SAP system at the connection destination, specify the port number to be used by the SAProuter.

F. Properties of PFM - Agent for Enterprise Applications

This appendix lists the properties of the Agent Store and Agent Collector services of PFM - Agent for Enterprise Applications that are displayed in PFM - Web Console.

F.1 List of Agent Store service properties

The following table lists the properties of the Agent Store service of PFM - Agent for Enterprise Applications.

Table F–1: Properties of the Agent Store service of PFM - Agent for Enterprise Applications

Folder name		Property name	Description
--		First Registration Date	Displays the first date and time the service was recognized by PFM - Manager.
		Last Registration Date	Displays the most recent date and time the service was recognized by PFM - Manager.
General		--	Stores information such as host names and directories. You cannot change properties stored in this folder.
		Directory	Displays the name of the current directory where the service is running.
		Host Name	Displays the name of the physical host where the service is running.
		Process ID	Displays the service's process ID.
		Physical Address	Displays the IP address and port number of the host where the service is running.
		User Name	Displays the name of the user that executed the service process.
		Time Zone	Displays the time zone in which the service is used.
System		--	Stores information about the operating system where the service is running. You cannot change properties stored in this folder.
		CPU Type	Displays the CPU type.
		Hardware ID	Displays the hardware ID.
		OS Type	Displays the type of operating system.
		OS Name	Displays the name of the operating system.
		OS Version	Displays the version of the operating system.
Network Services		--	Stores information about the Performance Management communication common library. You cannot change properties stored in this folder.
		Build Date	Displays the creation date of the Agent Store service.
		INI File	Displays the name of the directory containing the <code>jpcns.ini</code> file.
Network Services	Service	--	Stores information about the service. You cannot change properties stored in this folder.
		Description	Displays the host name in the following format: <i>instance-name_host-name</i>

Folder name		Property name	Description
Network Services	Service	Local Service Name	Displays the service ID.
		Remote Service Name	Displays the service ID of the Master Manager service at the connection-target PFM - Manager host.
		EP Service Name	Displays the service ID of the Correlator service at the connection-target PFM - Manager host.
Retention		--	Sets the data retention period. For details, see the chapter that describes management of operation monitoring data in the <i>JP1/Performance Management User's Guide</i> .
		Product Interval - Minute Drawer	Sets the retention period for records of the PI record type that are collected each minute. The following periods can be selected: <ul style="list-style-type: none"> • Minute • Hour • Day • 2 Days • 3 Days • 4 Days • 5 Days • 6 Days • Week • Month • Year
		Product Interval - Hour Drawer	Sets the retention period for records of the PI record type that are collected hourly. The following periods can be selected: <ul style="list-style-type: none"> • Hour • Day • 2 Days • 3 Days • 4 Days • 5 Days • 6 Days • Week • Month • Year
		Product Interval - Day Drawer	Sets the retention period for records of the PI record type that are collected daily. The following periods can be selected: <ul style="list-style-type: none"> • Day • 2 Days • 3 Days • 4 Days • 5 Days • 6 Days • Week • Month • Year
		Product Interval - Week Drawer	Sets the retention period for records of the PI record type that are collected weekly. The following periods can be selected: <ul style="list-style-type: none"> • Week • Month • Year

Folder name		Property name	Description
Retention		Product Interval - Month Drawer	Sets the retention period for records of the PI record type that are collected monthly. The following periods can be selected: <ul style="list-style-type: none"> • Month • Year
		Product Interval - Year Drawer	Sets the retention period for records of the PI record type that are collected annually. This retention period is fixed to Year .
		Product Detail - <i>record-ID-of-PD-record-type</i>	Sets the number of records to save, for records of the PD record type. You can specify an integer in the range from 0 to 2,147,483,647 (inclusive). Note: An error message is displayed if you specify an out-of-range value or a non-numeric character.
RetentionEx		--	Sets the data retention period for Store version 2.0. For details, see the chapter that describes managing operation monitoring data in the <i>JPI/Performance Management User's Guide</i> .
RetentionEx	Product Interval - <i>record-ID-of-PI-record-type</i>	--	Sets the retention period for records of the PI record type.
		Period - Minute Drawer (Day)	Sets the retention period for performance data that is collected minute-by-minute for each record ID of the PI record type. The permitted retention period (number of days) is an integer in the range from 0 to 366.
		Period - Hour Drawer (Day)	Sets the retention period for performance data that is collected hourly for each record ID of the PI record type. The permitted retention period (number of days) is an integer in the range from 0 to 366.
		Period - Day Drawer (Week)	Sets the retention period for performance data that is collected daily for each record ID of the PI record type. The permitted retention period (number of weeks) is an integer in the range from 0 to 522.
		Period - Week Drawer (Week)	Sets the retention period for performance data that is collected weekly for each record ID of the PI record type. The permitted retention period (number of weeks) is an integer in the range from 0 to 522.
		Period - Month Drawer (Month)	Sets the retention period for performance data that is collected monthly for each record ID of the PI record type. The permitted retention period (number of months) is an integer in the range from 0 to 120.
		Period - Year Drawer (Year)	Sets the retention period for performance data that is collected yearly for each record ID of the PI record type. The value 10 is always displayed. The retention period is unlimited.
	Product Detail - <i>record-ID-of-PD-record-type</i>	Period (Day)	Sets the retention period for performance data for each record ID of the PD record type. The permitted retention period (number of days) is an integer in the range from 0 to 366.
Disk Usage		--	This directory stores the amounts of disk space used by each database. Displayed disk space usage values are current as of the time of the display. You cannot change the properties stored in this directory.
		Product Interval	Displays the disk space used by records of the PI record type.
		Product Detail	Displays the disk space used by records of the PD record type.

Folder name	Property name	Description
Disk Usage	Product Alarm	Displays the disk space used by records of the PA record type. PFM - Agent for Enterprise Applications does not use this property.
	Product Log	Displays the disk space used by records of the PL record type. PFM - Agent for Enterprise Applications does not use this property.
	Total Disk Usage	Displays the total amount of disk space used by the entire database.
Configuration	--	Displays the properties of the Agent Store service.
	Store Version	Displays the version of the Store database. <ul style="list-style-type: none"> For Store version 1.0: 1.0 For Store version 2.0: 2.0

Legend:

--: Not applicable

F.2 List of Agent Collector service properties

The following table lists the properties of the Agent Collector service of PFM - Agent for Enterprise Applications.

Table F–2: Properties of the Agent Collector service of PFM - Agent for Enterprise Applications

Folder name	Property name	Description
--	First Registration Date ^{#1}	Displays the first date and time the service was recognized by PFM - Manager.
	Last Registration Date ^{#1}	Displays the most recent date and time the service was recognized by PFM - Manager.
	Data Model Version	Displays the version of data model.
General	--	Stores information such as host names and directories. You cannot change properties stored in this folder.
	Directory	Displays the name of the current directory where the service is running.
	Host Name	Displays the name of the physical host where the service is running.
	Process ID	Displays the service's process ID.
	Physical Address	Displays the IP address and port number of the host where the service is running.
	User Name	Displays the name of the user that executed the service process.
	Time Zone	Displays the time zone in which the service is used.
System	--	Stores information about the operating system where the service is running. You cannot change properties stored in this folder.

Folder name		Property name	Description
System		CPU Type	Displays the CPU type.
		Hardware ID	Displays the hardware ID.
		OS Type	Displays the type of operating system.
		OS Name	Displays the name of the operating system.
		OS Version	Displays the version of the operating system.
Network Services		--	Stores information about the Performance Management communication common library. You cannot change properties stored in this folder.
		Build Date	Displays the creation date of the Agent Collector service.
		INI File	Displays the name of the directory containing the <code>jpcns.ini</code> file.
Network Services	Service	--	Stores information about the service. You cannot change properties stored in this folder.
		Description	Displays the host name in the following format: <i>instance-name_host-name</i>
		Local Service Name	Displays the service ID.
		Remote Service Name	Displays the service ID of the Agent Store service to which the Agent Collector service connects.
		AH Service Name	Displays the service ID of the Action Handler service on the same host.
JP1 Event Configurations		--	Sets the JP1 event issuance conditions.
		<i>each-service</i>	Selects either Yes or No from the list item for the Agent Collector, Agent Store, Action Handler, and Status Serve services to specify whether JP1 system events are to be issued for each service.
		JP1 Event Send Host	Specifies the connection-target event server name of JP1/Base. The specified server event must be running on the logical host or physical host on the same machine as for the Action Handler service. The permitted value is from 0 to 255 bytes of single-byte characters. You can use alphanumeric characters, the period (.), and the hyphen (-). If the specified value is outside the permitted range, the system assumes that no value is specified. If no value is specified, the host on which the Action Handler service is running is assumed to be the host that issues events. If <code>localhost</code> is specified, the system assumes that the physical host is specified.
		Monitoring Console Host	Specifies the PFM - Web Console host to be started when PFM - Web Console's browser is started at the time of monitor startup by JP1/IM - Manager. The permitted value is from 0 to 255 bytes of single-byte characters. You can use alphanumeric characters, the period (.), and the hyphen (-). If the specified value is outside the permitted range, the system assumes that no value is specified. If no value is specified, the system assumes the connection-target PFM - Manager host.
		Monitoring Console Port	Specifies the port number of the PFM - Web Console that is to be started (HTTP requested port number). The permitted value range is from 1 to 65,535. If the specified value is

Folder name		Property name	Description
JP1 Event Configurations		Monitoring Console Port	outside the permitted range, the system assumes that no value is specified. If no value is specified, 20358 is set.
		Monitoring Console Https	When PFM - Web Console starts automatically when JP1/IM - Manager monitoring starts, this property specifies whether the connection to PFM - Web Console is to be by encrypted communication that uses https. The default is No. <ul style="list-style-type: none"> • Yes: Connect using encrypted communication • No: Connect without using encrypted communication
JP1 Event Configurations	Alarm	JP1 Event Mode	Sets whether JP1 system events or JP1 user events are to be issued when the alarm status changes. <ul style="list-style-type: none"> • JP1 User Event: Issues JP1 user events. • JP1 System Event: Issues JP1 system events.
Detail Records		--	Stores the properties of records of the PD record type. The record IDs of the collected records are displayed in a bold typeface.
Detail Records	<i>record-ID</i> ^{#2}	--	Stores the properties of a record.
		Description	Displays a description of the record. You cannot change this property.
		Log	Select Yes or No from the list to specify whether the record is to be logged into (stored in) the Store database. If this value is set to Yes and Collection Interval is set to a value greater than 0, the record is logged into the database.
		Log(ITSLM)	Displays either Yes or No indicating whether records are to be recorded from JP1/SLM - Manager into the Store database of PFM - Agent for Enterprise Applications. Only applicable if PFM - Agent for Enterprise Applications is linked with JP1/SLM - Manager. If PFM - Agent for Enterprise Applications is not linked with JP1/SLM - Manager, No is always displayed. This property cannot be changed.
		Monitoring(ITSLM)	Displays either Yes or No as the setting in JP1/SLM - Manager indicating whether records are to be sent to JP1/SLM - Manager. This is applicable only if PFM - Agent for Enterprise Applications is linked with JP1/SLM - Manager. If PFM - Agent for Enterprise Applications is not linked with JP1/SLM - Manager, No is always displayed. This property cannot be changed.
		Collection Interval ^{#3}	Specifies the data collection interval. You can specify a value from 0 to 2,147,483,647 seconds (inclusive) in increments of 1. If you specify 0 for the property, 0 seconds is assumed, in which case no data is collected.
		Collection Offset ^{#3}	Specifies the offset value (in seconds) for starting data collection. The specified value must not exceed the value specified for Collection Interval and must be in the range from 0 to 32,767 seconds (inclusive). The storage time for data collection does not depend on the Collection Offset value and is the same time as the Collection Interval.
		Over 10 Sec Collection Time	Displayed only when collection of history data takes priority over display of real-time reports (when the history collection priority function is enabled). Yes or No is displayed depending on whether record collection will require at least 10 seconds: <ul style="list-style-type: none"> • Yes: Might require 10 seconds or more

Folder name		Property name	Description
Detail Records	<i>record-ID</i> #2	Over 10 Sec Collection Time	<ul style="list-style-type: none"> No: Will require less than 10 seconds This property cannot be changed.
		Realtime Report Data Collection Mode	Displayed only when collection of history data takes priority over display of real-time reports (when the history collection priority function is enabled). Specifies the real-time report display mode: <ul style="list-style-type: none"> Reschedule: Reschedule mode Temporary Log: Temporary log mode The temporary log mode (<i>Temporary Log</i>) must be specified for records for which the value of Over 10 Sec Collection Time is <i>Yes</i> .
		LOGIF	Specifies the conditions for storing records in the database. Only records that satisfy the conditions are stored in the database. This property displays the conditional expression (character string) that was created in the LOGIF Expression Editor window, which is displayed by clicking LOGIF in the lower frame of the service property window, which is displayed by clicking the Services tab in PFM - Web Console.
Interval Records		--	Stores the properties of records of the PI record type. The record IDs of the collected records are displayed in a bold typeface.
Interval Records	<i>record-ID</i> #2	--	Stores the properties of a record.
		Description	Displays a description of the record. You cannot change this property.
		Log	Select Yes or No from the list to specify whether the record is to be logged into (stored in) the Store database. If this property is set to Yes and Collection Interval is set to a value greater than 0, the record is logged into the database.
		Log(ITSLM)	Displays either Yes or No indicating whether records are to be recorded from JP1/SLM - Manager into the Store database of PFM - Agent for Enterprise Applications. This is applicable only if PFM - Agent for Enterprise Applications is linked with JP1/SLM - Manager. If PFM - Agent for Enterprise Applications is not linked with JP1/SLM - Manager, No is always displayed. This property cannot be changed.
		Monitoring(ITSLM)	Displays either Yes or No as the setting in JP1/SLM - Manager indicating whether records are to be sent to JP1/SLM - Manager. This is applicable only if PFM - Agent for Enterprise Applications is linked with JP1/SLM - Manager. If PFM - Agent for Enterprise Applications is not linked with JP1/SLM - Manager, No is always displayed. This property cannot be changed.
		Collection Interval	Sets the data collection interval. You can specify a value from 0 to 2,147,483,647 seconds (inclusive) in increments of 1. If you specify 0 for the property, 0 seconds is assumed, in which case no data is collected.
		Collection Offset	Sets the offset value (in seconds) for starting data collection. The specified value must not exceed the value specified for Collection Interval and must be in the range from 0 to 32,767 seconds (inclusive). The storage time for data collection does not depend on the Collection Offset value and is the same time as the Collection Interval.

Folder name		Property name	Description
Interval Records	<i>record-ID</i> ^{#2}	Over 10 Sec Collection Time	<p>Displayed only when collection of history data takes priority over display of real-time reports (when the history collection priority function is enabled). Yes or No is displayed depending on whether record collection will require at least 10 seconds:</p> <ul style="list-style-type: none"> • Yes: Might require 10 seconds or more • No: Will require less than 10 seconds <p>This property cannot be changed.</p>
		Realtime Report Data Collection Mode	<p>Displayed only when collection of history data takes priority over display of real-time reports (when the history collection priority function is enabled).</p> <p>Specifies the real-time report display mode:</p> <ul style="list-style-type: none"> • Reschedule: Reschedule mode • Temporary Log: Temporary log mode <p>The temporary log mode (Temporary Log) must be specified for records for which the value of Over 10 Sec Collection Time is Yes.</p>
		LOGIF	<p>Sets the conditions for storing records in the database. Only records that satisfy the conditions are stored in the database. This property displays the conditional expression (character string) that was created in the LOGIF Expression Editor window, which is displayed by clicking LOGIF in the lower frame of the service property window, which is displayed by clicking the Services tab in PFM - Web Console.</p>
Log Records		--	Stores the properties of records of the PL record type. Because PFM - Agent for Enterprise Applications does not support this record type, do not use this property.
Restart Configurations		--	<p>Sets automatic restart conditions for PFM services. This property is supported by PFM - Manager and PFM - Base 09-00 or later. For details about the automatic PFM service restart function, see the chapter that describes the functions of Performance Management in the <i>JP1/Performance Management Planning and Configuration Guide</i>.</p>
		Restart when Abnormal Status	Sets whether services are to be restarted automatically if the Status Server service cannot acquire the status of Action Handler, Agent Collector, and Agent Store services successfully.
		Restart when Single Service Running	Sets whether the other service is to be restarted automatically if only the Agent Store service or Agent Collector service is running.
Restart Configurations	Action Handler	Auto Restart	Sets whether the automatic restart function is to be used on the Action Handler service.
		Auto Restart - Interval (Minutes)	Sets the interval at which the service status is to be checked if the automatic restart function is used. The permitted value is in the range from 1 through 1,440 minutes, which can only be set in minutes.
		Auto Restart - Repeat Limit	Sets an integer from 1 through 10 specifying the number of times the restart is to be retried consecutively if the automatic restart function is used.
		Scheduled Restart	Sets whether the scheduled restart function is to be used on the Action Handler service by selecting either Yes or No from the list item.

Folder name		Property name	Description
Restart Configurations	Action Handler	Scheduled Restart - Interval	Sets an integer from 1 through 1,000 as the restart interval if the scheduled restart function is used.
		Scheduled Restart - Interval Unit	Sets the unit for restart interval by selecting Hour , Day , Week , or Month from the list items if the scheduled restart function is used.
		Scheduled Restart - Origin - Year	Specifies an integer in the range from 1971 to 2035 as the year in which restart is to be executed.
		Scheduled Restart - Origin - Month	Specifies an integer in the range from 1 to 12 as the month in which restart is to be executed.
		Scheduled Restart - Origin - Day	Specifies an integer in the range from 1 to 31 as the day of the month on which restart is to be executed.
		Scheduled Restart - Origin - Hour	Specifies an integer in the range from 0 to 23 as the time (hour) at which restart is to be executed.
		Scheduled Restart - Origin - Minute	Specifies an integer in the range from 0 to 59 as the time (minute) at which restart is to be executed.
	Agent Collector	Auto Restart	Sets whether the automatic restart function is to be used on the Agent Collector service.
		Auto Restart - Interval (Minutes)	Sets an interval at which the service status is to be checked if the automatic restart function is used. The permitted value is in the range from 1 through 1,440 minutes, which can only be set in minutes.
		Auto Restart - Repeat Limit	Sets an integer from 1 through 10 as the number of times the restart is to be retried consecutively if the automatic restart function is used.
		Scheduled Restart	Sets whether the scheduled restart function is to be used on the Agent Collector service by selecting either Yes or No from the list item.
		Scheduled Restart - Interval	Sets an integer from 1 through 1,000 as the restart interval if the scheduled restart function is used.
		Scheduled Restart - Interval Unit	Sets the unit for restart interval by selecting Hour , Day , Week , or Month from the list items if the scheduled restart function is used.
		Scheduled Restart - Origin - Year	Specifies an integer in the range from 1971 to 2035 as the year in which restart is to be executed.
		Scheduled Restart - Origin - Month	Specifies an integer in the range from 1 to 12 as the month in which restart is to be executed.
		Scheduled Restart - Origin - Day	Specifies an integer in the range from 1 to 31 as the day of the month on which restart is to be executed.
		Scheduled Restart - Origin - Hour	Specifies an integer in the range from 0 to 23 as the time (hour) at which restart is to be executed.
		Scheduled Restart - Origin - Minute	Specifies an integer in the range from 0 to 59 as the time (minute) at which restart is to be executed.
		Agent Store	Auto Restart
	Auto Restart - Interval (Minute)		Sets an interval at which the service status is to be checked if the automatic restart function is used. The permitted value is

Folder name		Property name	Description
Restart Configurations	Agent Store	Auto Restart - Interval (Minute)	in the range from 1 through 1,440 minutes, which can only be set in minutes.
		Auto Restart - Repeat Limit	Sets an integer from 1 through 10 as the number of times the restart is to be retried consecutively if the automatic restart function is used.
		Scheduled Restart	Sets whether the scheduled restart function is to be used on the Agent Store service by selecting either Yes or No from the list item.
		Scheduled Restart - Interval	Sets an integer from 1 through 1,000 as the restart interval if the scheduled restart function is used.
		Scheduled Restart - Interval Unit	Sets the unit for restart interval by selecting Hour , Day , Week , or Month from the list items if the scheduled restart function is used.
		Scheduled Restart - Origin - Year	Specifies an integer in the range from 1971 to 2035 as the year in which restart is to be executed.
		Scheduled Restart - Origin - Month	Specifies an integer in the range from 1 to 12 as the month in which restart is to be executed.
		Scheduled Restart - Origin - Day	Specifies an integer in the range from 1 to 31 as the day of the month on which restart is to be executed.
		Scheduled Restart - Origin - Hour	Specifies an integer in the range from 0 to 23 as the time (hour) at which restart is to be executed.
		Scheduled Restart - Origin - Minute	Specifies an integer in the range from 0 to 59 as the time (minute) at which restart is to be executed.
ITSLM Connection Configuration		--	Displays information about the link to JP1/SLM - Manager, if there is a connection to one.
ITSLM Connection Configuration	ITSLM Connection	--	Displays information about the connection -target JP1/SLM - Manager.
		ITSLM Host	Displays the host name of connected JP1/SLM - Manager. If PFM - Agent for Enterprise Applications is not connected to JP1/SLM - Manager, this property is not displayed.
		ITSLM Port	Displays the port number of connected JP1/SLM - Manager. If PFM - Agent for Enterprise Applications is not connected to JP1/SLM - Manager, this property is not displayed.
	MANAGE ITSLM CONNECTION	--	Sets whether JP1/SLM - Manager is to be disconnected.
		DISCONNECT ITSLM CONNECTION	Selects the host name of the JP1/SLM - Manager that is to be disconnected from a list of items. If the null character is selected from the list, nothing is done. If PFM - Agent for Enterprise Applications is not connected to JP1/SLM - Manager, only the null character is displayed in the list.
Agent		--	Stores the properties for the settings of PFM - Agent specific to SAP system.
Agent	Target	--	Displays an overview of the SAP system being monitored. You cannot change properties stored in this directory.
		SID	Displays the ID of the SAP system being monitored.
		SERVER	Displays the name of the SAP instance being monitored.
	Destination	--	Displays information needed to connect to the SAP system. You cannot change properties stored in this folder.

Folder name		Property name	Description
Agent	Destination	ASHOST	Displays the host name of the connection-target application server. Normally, the name of the local host is displayed.
		SYSNR	Displays the system number of the SAP system.
		CLIENT	Displays the client name to which the SAP user belongs (system number assigned to the connection-target dialog instance).
		USER	Displays the SAP user name.
		EXTPWD	Displays whether an extended password is to be used to connect to the SAP system. <ul style="list-style-type: none"> Y: Uses an extended password. N: Does not use an extended password.
		PASSWD	Displays asterisks (*) for the password of the SAP user.
		LANG	Displays the language of the SAP user or of the connection-target SAP system. It is always EN.
		CODEPAGE	Displays the code page that is used to connect to the SAP system. This information is always blank.
	Mode	--	Displays the operating mode of the Agent Collector service. You cannot change properties stored in this folder.
		DELAYCONNECT	Displays when the SAP system is to be connected: <ul style="list-style-type: none"> Y: Connect to the SAP system only when performance data is collected. In this case, the Agent Collector service is started regardless of the operating status of the SAP system during connection establishment. N: Connect to the SAP system when the Agent Collector service starts. In this case, the Agent Collector service is not started if the SAP system is inactive during connection establishment.
		KEEPCONNECT	Displays whether the SAP system is to remain connected after collection of performance data is completed. It is always Y. <ul style="list-style-type: none"> Y: Maintain the connection. N: Do not maintain the connection.
	PI_UMP	MONITOR_SET	Specifies the monitor set name for the SAP system monitor information that is to be the monitoring target for User defined Monitor (Perf.) (PI_UMP) records. You can specify a character string of 1 to 60 bytes of alphanumeric characters.
		MONITOR	Specifies the monitor set name for the SAP system monitor information that is to be the monitoring target for User defined Monitor (Perf.) (PI_UMP) records. You can specify a character string of 1 to 60 bytes of alphanumeric characters.

Legend:

--: Not applicable

#1

If you display the Properties - [Service] dialog box from the Performance Management - View window, the `First Registration Date` and `Last Registration Date` properties are not displayed. To view these property values, display the Properties - [Service] dialog box from the Administration Tool window.

#2

The folder name shows the record ID without the database ID. For details about the record ID of each record, see [Chapter 10. Records](#).

#3

If Sync Collection With is displayed, neither Collection Interval nor Collection Offset is displayed.

G. Lists of Directories and Files

This appendix lists the files and directories of PFM - Agent for Enterprise Applications for each OS.

The installation directory of Performance Management is displayed for each OS.

In Windows:

You can specify any folder as the installation directory of Performance Management. The following are the default installation directory folders:

- In Windows
`system-drive\Program Files(x86)\Hitachi\jp1pc\`

G.1 List of folders and files (Windows)

The following table lists the files and folders for the Windows version of PFM - Agent for Enterprise Applications.

Table G–1: Files and folders for PFM - Agent for Enterprise Applications (Windows)

Folder name	Filename	Description
<i>installation-folder</i> \agtm\	--	Base folder of PFM - Agent for Enterprise Applications
	readme_ja.txt	README.TXT (Japanese)
	readme_en.txt	README.TXT (English)
	version.txt	Version information
<i>installation-folder</i> \agtm\agent\	--	Base folder of the Agent Collector service
	jpcagtm.exe	Executable program of the Agent Collector service
	jpcMcollect.exe	Child process of the Agent Collector service execution program jpcagtm.exe. Runs communications with the SAP system.
<i>installation-folder</i> \agtm\agent\ <i>instance-name</i> \	--	Base folder of the Agent Collector service (for each instance) ^{#1}
	jpcagt.ini	Agent Collector service startup initialization file (for each instance) ^{#1}
	jpcagt.ini.model	Model file for the Agent Collector service startup initialization file (for each instance) ^{#1}
	jpcMcollect.ini	Environment parameters file of SAP communication process ^{#1}
	jr3alget.ini	Environment parameters file for CCMS Alert Monitor Command (PD_ALMX) records ^{#1}
	jr3slget.ini	Environment parameters file for System Log Monitor Command (PD_SLMX) records ^{#1}
<i>installation-folder</i> \agtm\agent\ <i>instance-name</i> \log\	--	Storage folder for internal log files of the Agent Collector service (for each instance) ^{#1}
	ALERT	CCMS Alert Information storage file in the WRAP1 format (default) ^{#3}

Folder name	Filename	Description
<i>installation-folder</i> \agtm\agent\ <i>instance-name</i> \log\	ALERT n ^{#8}	CCMS Alert Information storage file in the WRAP2 format ^{#3}
	ALERT.ofs	Management file for CCMS alert information (default) ^{#3}
	jr3alget.log	Message log file storing the CCMS alert information extraction history ^{#3}
	jr3alget.dat	Data log file storing the CCMS alert information extraction history ^{#3}
	jr3alget.lasttime	Timestamp file containing the previous date and time that CCMS alert information was extracted ^{#3}
	SYSLOG	System log information storage file in the WRAP1 format (default) ^{#4}
	SYSLOG n ^{#8}	System log information storage file in the WRAP2 format ^{#4}
	SYSLOG.ofs	Management file for the system log information storage file (default) ^{#4}
	jr3slget.log	Message log file storing the system log information extraction history ^{#4}
	jr3slget.dat	Data log file storing the system log information extraction history ^{#4}
	jr3slget.lasttime	Timestamp file containing the previous date and time that system log information was extracted ^{#4}
<i>installation-folder</i> \agtm\evtrap\	--	Root directory of SAP event management function
	jr3alget	CCMS alert extraction and conversion command
	jr3alget.ini.sample	Model file for the jr3alget command's environment parameters file
	jr3slget	System log extraction and conversion command
	jr3slget.ini.sample	Model file for the jr3slget command's environment parameters file
<i>installation-folder</i> \agtm\lib\	--	Storage folder for message catalogs
<i>installation-folder</i> \agtm\lib\rfc	--	Storage folder for RFC libraries
<i>installation-folder</i> \agtm\store\	--	Base directory of the Agent Store service
	*.DAT	Data model definition file
<i>installation-folder</i> \agtm\store\ <i>instance-name</i> \	--	Base folder of the Agent Store service (for each instance) ^{#1}
	*.DB	Performance data file (for each instance) ^{#2}
	*.IDX	Index file for performance data files (for each instance) ^{#2}
	*.LCK	Lock file for performance data files (for each instance) ^{#2}
	jpcsto.ini	Agent Store service startup initialization file (for each instance) ^{#1}

Folder name	Filename	Description
<i>installation-folder</i> \agtm\store\ <i>instance-name</i> \	jpcsto.ini.model	Model file for the Agent Store service startup initialization file (for each instance) ^{#1}
	*.DAT	Data model definition file (for each instance) ^{#1}
<i>installation-folder</i> \agtm\store\ <i>instance-name</i> \backup\	--	Default database backup folder (for each instance) ^{#1}
<i>installation-folder</i> \agtm\store\ <i>instance-name</i> \dump\	--	Default database export folder (for each instance) ^{#1}
<i>installation-folder</i> \agtm\store\ <i>instance-name</i> \import\	--	Default database export folder for Store version 2.0 (for each instance) ^{#5}
<i>installation-folder</i> \agtm\store\ <i>instance-name</i> \log\	--	Storage folder for internal log files of the Agent Store service (for each instance) ^{#1}
<i>installation-folder</i> \agtm\store\ <i>instance-name</i> \partial\	--	Default database partial backup folder for Store version 2.0 (for each instance) ^{#5}
<i>installation-folder</i> \agtm\store\ <i>instance-name</i> \STPD\	--	Base folder for performance data of the PD record type for Store version 2.0 (for each instance) ^{#5}
<i>installation-folder</i> \agtm\store\ <i>instance-name</i> \STPI\	--	Base folder for performance data of the PI record type for Store version 2.0 (for each instance) ^{#5}
<i>installation-folder</i> \agtm\store\ <i>instance-name</i> \STPL\	--	Base folder for performance data of the PL record type for Store version 2.0 (for each instance) ^{#5}
<i>installation-folder</i> \agtm\ <i>instance-name</i> \log\	*.*	Log files for PFM - Agent for Enterprise Applications
<i>installation-folder</i> \patch_files\agtm\	--	Storage folder for patch files
<i>installation-folder</i> \auditlog\	--	Default output folder for action log files
	jpcauditn ^{#8} .log	Action log file ^{#6}
<i>installation-folder</i> \setup\	--	Storage folder for setup files
	jpcagtmu.Z	Archive file for PFM - Agent setup (UNIX)
	jpcagtmw.EXE	Archive file for PFM - Agent setup (Windows)
<i>environment-directory</i> ^{#7} \jplpc\agtm\agent\ <i>instance-name</i> \	--	Base folder of the Agent Collector service for logical host operation (for each instance) ^{#1}
	jpcagt.ini	Agent Collector service startup initialization file for logical host operation (for each instance) ^{#1}
	jpcagt.ini.model	Model file for the Agent Collector service startup initialization file for logical host operation (for each instance) ^{#1}
	jpcMcollect.ini	Environment parameters file for SAP communication process for logical host operation ^{#1}
	jr3alget.ini	Environment parameters file for CCMS Alert Monitor Command (PD_ALMX) records for logical host operation ^{#1}
	jr3slget.ini	Environment parameters file for System Log Monitor Command (PD_SLMX) records for logical host operation ^{#1}

Folder name	Filename	Description
<i>environment-directory</i> ^{#7} \jplpc\agtm\agent\ <i>instance-name</i> \log\	--	Storage folder for internal log files of the Agent Collector service for logical host operation (for each instance) ^{#1}
	ALERT	CCMS Alert Information storage file in the WRAP1 format for logical host use (default) ^{#3}
	ALERT ⁿ ^{#8}	CCMS Alert Information storage file in the WRAP2 format for logical host use (default) ^{#3}
	ALERT.ofs	Management file for the CCMS alert information storage file for logical host operation (default) ^{#3}
	jr3alget.log	Message log file storing the CCMS alert information extraction history for logical host operation ^{#3}
	jr3alget.dat	Data log file storing the CCMS alert information extraction history for logical host operation ^{#3}
	jr3alget.lasttime	Timestamp file containing the previous date and time that CCMS alert information was extracted for logical host operation ^{#3}
	SYSLOG	System log information storage file in the WRAP1 format for logical host use (default) ^{#4}
	SYSLOG ⁿ ^{#8}	System log information storage file in the WRAP2 format for logical host use (default) ^{#4}
	SYSLOG.ofs	Management file for the system log information storage file for logical host operation (default) ^{#4}
	jr3slget.log	Message log file storing the system log information extraction history for logical host operation ^{#4}
	jr3slget.dat	Data log file storing the system log information extraction history for logical host operation ^{#4}
	jr3slget.lasttime	Timestamp file containing the previous date and time that system log information was extracted for logical host operation ^{#4}
<i>environment-directory</i> ^{#7} \jplpc\agtm\store\ <i>instance-name</i> \	--	Base folder of the Agent Store service for logical host operation (for each instance) ^{#1}
	*.DB	Performance data file for logical host operation (for each instance) ^{#2}
	*.IDX	Index file for performance data files for logical host operation (for each instance) ^{#2}
	*.LCK	Lock files for performance data files for logical host operation (for each instance) ^{#2}
	jpcsto.ini	Agent Store service startup initialization file (for each instance) ^{#1}
	jpcsto.ini.model	Model file for the Agent Store service startup initialization file for logical host operation (for each instance) ^{#1}
	*.DAT	Data model definition file for logical host operation (for each instance) ^{#1}

Folder name	Filename	Description
<i>environment-directory</i> ^{#7} \jplpc\agtm\store\ <i>instance-name</i> \backup\	--	Default database backup folder for logical host operation (for each instance) ^{#1}
<i>environment-directory</i> ^{#7} \jplpc\agtm\store\ <i>instance-name</i> \dump\	--	Default database export folder for logical host operation (for each instance) ^{#1}
<i>environment-directory</i> ^{#7} \jplpc\agtm\store\ <i>instance-name</i> \import\	--	Default database import folder for Store version 2.0 for logical host operation (for each instance) ^{#5}
<i>environment-directory</i> ^{#7} \jplpc\agtm\store\ <i>instance-name</i> \log\	--	Storage folder for internal log files of the Agent Store service for logical host operation (for each instance) ^{#1}
<i>environment-directory</i> ^{#7} \jplpc\agtm\store\ <i>instance-name</i> \partial\	--	Default database partial backup folder for Store version 2.0 for logical host operation (for each instance) ^{#5}
<i>environment-directory</i> ^{#7} \jplpc\agtm\store\ <i>instance-name</i> \STPD\	--	Base folder for performance data of the PD record type for Store version 2.0 for logical host operation (for each instance) ^{#5}
<i>environment-directory</i> ^{#7} \jplpc\agtm\store\ <i>instance-name</i> \STPI\	--	Base folder for performance data of the PI record type for Store version 2.0 for logical host operation (for each instance) ^{#5}
<i>environment-directory</i> ^{#7} \jplpc\agtm\store\ <i>instance-name</i> \STPL\	--	Base folder for performance data of the PL record type for Store version 2.0 for logical host operation (for each instance) ^{#5}
<i>environment-directory</i> ^{#7} \jplpc\auditlog\	--	Default output folder for action log files for logical host operation
	jpcaudit ^{#8} .log	Action log file for logical host operation ^{#6}

Legend:

--: Not applicable

#1

This is created by the execution of the `jpcconf inst setup` command.

#2

This is created when the Agent Store service is started.

#3

This is created when a CCMS Alert Monitor Command (PD_ALMX) record is collected.

#4

This is created when a System Log Monitor Command (PD_SLMX) record is collected.

#5

This is created when Store version 2.0 is used to configure the Store database.

#6

You can use the `jpccomm.ini` file to change the number of log files.

#7

The environment directory is on the shared disk that was specified when the logical host was created.

#8

n indicates a numeric value.

G.2 List of directories and files (Linux)

The following table lists the files and directories for the Linux version of PFM - Agent for Enterprise Applications.

Table G–2: Files and directories for PFM - Agent for Enterprise Applications (Linux)

Directory name	File name	Description
/opt/jp1pc/agtm/	--	Base directory of PFM - Agent for Enterprise Applications
/opt/jp1pc/agtm/agent/	--	Base directory of the Agent Collector service
	jpccagtm	Executable program of the Agent Collector service
	jpccmcollect	Child process of the Agent Collector service execution program <code>jpccagtm.exe</code> . Runs communications with the SAP system.
/opt/jp1pc/agtm/agent/ <i>instance-name</i> /	--	Base directory of the Agent Collector service (for each instance) ^{#1}
	jpccagt.ini	Agent Collector service startup initialization file (for each instance) ^{#1}
	jpccagt.ini.lock	Lock file for an Agent Collector service startup initialization file (for each instance) ^{#2}
	jpccagt.ini.model	Model file for the Agent Collector service startup initialization file (for each instance) ^{#1}
	jpccmcollect.ini	Environment parameters file of SAP communication process ^{#1}
	jr3alget.ini	Environment parameters file for CCMS Alert Monitor Command (PD_ALMX) records ^{#1}
	jr3slget.ini	Environment parameters file for System Log Monitor Command (PD_SLMX) records ^{#1}
/opt/jp1pc/agtm/agent/ <i>instance-name</i> /log/	--	Storage directory for internal log files of the Agent Collector service (for each instance) ^{#1}
	ALERT	CCMS Alert Information storage file in the WRAP1 format (default) ^{#3}
	ALERT ^{#9}	CCMS Alert Information storage file in the WRAP2 format ^{#3}
	ALERT.ofs	Management file for CCMS alert information (default) ^{#4}
	jr3alget.log	Message log file storing the CCMS alert information extraction history ^{#4}
	jr3alget.dat	Data log file storing the CCMS alert information extraction history ^{#4}
	jr3alget.lasttime	Timestamp file containing the previous date and time that CCMS alert information was extracted ^{#4}
	SYSLOG	System log information storage file in the WRAP1 format (default) ^{#4}
	SYSLOG ^{#9}	System log information storage file in the WRAP2 format ^{#4}

Directory name	File name	Description
/opt/jp1pc/agtm/agent/ <i>instance-name</i> /log/	SYSLOG.ofs	Management file for the system log information storage file (default) ^{#5}
	jr3slget.log	Message log file storing the system log information extraction history ^{#5}
	jr3slget.dat	Data log file storing the system log information extraction history ^{#5}
	jr3slget.lasttime	Timestamp file containing the previous date and time that system log information was extracted ^{#5}
/opt/jp1pc/agtm/evtrap/	--	Root directory of SAP event management function
	jr3alget	CCMS alert extraction and conversion command
	jr3alget.ini.sample	Model file for the jr3alget command's environment parameters file
	jr3slget	System log extraction and conversion command
	jr3slget.ini.sample	Model file for the jr3slget command's environment parameters file
/opt/jp1pc/agtm/lib/rfc	--	Storage directory for RFC library
/opt/jp1pc/agtm/nls/	--	Storage folder for message catalogs
/opt/jp1pc/agtm/store/	--	Base directory of the Agent Store service
	*.DAT	Data model definition file
/opt/jp1pc/agtm/store/ <i>instance-name</i> /	--	Base directory of the Agent Store service (for each instance) ^{#1}
	*.DB	Performance data file (for each instance) ^{#3}
	*.IDX	Index file for performance data files (for each instance) ^{#3}
	*.LCK	Lock file for performance data files (for each instance) ^{#3}
	jpcsto.ini	Agent Store service startup initialization file (for each instance) ^{#1}
	jpcsto.ini.model	Model file for the Agent Store service startup initialization file (for each instance) ^{#1}
	*.DAT	Data model definition file (for each instance) ^{#1}
/opt/jp1pc/agtm/store/ <i>instance-name</i> /backup/	--	Default database backup directory (for each instance) ^{#1}
/opt/jp1pc/agtm/store/ <i>instance-name</i> /dump/	--	Default database export directory (for each instance) ^{#1}
/opt/jp1pc/agtm/store/ <i>instance-name</i> /import/	--	Default database import directory for Store version 2.0 (for each instance) ^{#6}
/opt/jp1pc/agtm/store/ <i>instance-name</i> /log/	--	Storage directory for internal log files of the Agent Store service (for each instance) ^{#1}
/opt/jp1pc/agtm/store/ <i>instance-name</i> /partial/	--	Default database partial backup directory for Store version 2.0 (for each instance) ^{#6}

Directory name	File name	Description
/opt/jplpc/agt/store/instance-name/STPD/	--	Base folder for performance data of the PD record type for Store version 2.0 (for each instance) ^{#6}
/opt/jplpc/agt/store/instance-name/STPI/	--	Base folder for performance data of the PI record type for Store version 2.0 (for each instance) ^{#6}
/opt/jplpc/agt/store/instance-name/STPL/	--	Base folder for performance data of the PL record type for Store version 2.0 (for each instance) ^{#6}
/opt/jplpc/patch_files/agt/	--	Storage directory for patch files
/opt/jplpc/auditlog/	--	Default output folder for action log files
	jpcauditn ^{#9} .log	Action log file ^{#7}
/opt/jplpc/setup/	--	Storage directory for setup files
	jpcagtmu.Z	Archive file for PFM - Agent setup (UNIX)
	jpcagtmw.EXE	Archive file for PFM - Agent setup (Windows)
environment-directory ^{#8} /jplpc/agt/agent/instance-name/	--	Base directory of the Agent Collector service for logical host operation (for each instance) ^{#1}
	jpcagt.ini	Agent Collector service startup initialization file for logical host operation (for each instance) ^{#1}
	jpcagt.ini.model	Model file for the Agent Collector service startup initialization file for logical host operation (for each instance) ^{#1}
	jpcMcollect.ini	Environment parameters file for SAP communication process for logical host operation ^{#1}
	jr3alget.ini	Environment parameters file for CCMS Alert Monitor Command (PD_ALMX) records for logical host operation ^{#1}
	jr3slget.ini	Environment parameters file for System Log Monitor Command (PD_SLMX) records for logical host operation ^{#1}
environment-directory ^{#8} /jplpc/agt/agent/instance-name/log/	--	Storage directory for internal log files of the Agent Collector service for logical host operation (for each instance) ^{#1}
	ALERT	CCMS Alert Information storage file in the WRAP1 format for logical host use (default) ^{#3}
	ALERTn ^{#9}	CCMS Alert Information storage file in the WRAP2 format for logical host use (default) ^{#3}
	ALERT.ofs	Management file for the CCMS alert information storage file for logical host operation (default) ^{#4}
	jr3alget.log	Message log file storing the CCMS alert information extraction history for logical host operation ^{#4}
	jr3alget.dat	Data log file storing the CCMS alert information extraction history for logical host operation ^{#4}
	jr3alget.lasttime	Timestamp file containing the previous date and time that CCMS alert information was extracted for logical host operation ^{#4}

Directory name	File name	Description
<i>environment-directory</i> ^{#8} / <i>jp1pc/agt/agent/instance-name/log/</i>	SYSLOG	System log information storage file in the WRAP1 format for logical host use (default) ^{#4}
	SYSLOGn ^{#9}	System log information storage file in the WRAP2 format for logical host use (default) ^{#4}
	SYSLOG.ofs	Management file for the system log information storage files for logical host operation (default) ^{#5}
	jr3slget.log	Message log file storing the system log information extraction history for logical host operation ^{#5}
	jr3slget.dat	Data log file storing the system log information extraction history for logical host operation ^{#5}
	jr3slget.lasttime	Timestamp file containing the previous date and time that system log information was extracted for logical host operation ^{#5}
<i>environment-directory</i> ^{#8} / <i>jp1pc/agt/store/instance-name/</i>	--	Base directory of the Agent Store service for logical host operation (for each instance) ^{#1}
	*.DB	Performance data file for logical host operation (for each instance) ^{#3}
	*.IDX	Index file for performance data files for logical host operation (for each instance) ^{#3}
	*.LCK	Lock file for performance data files for logical host operation (for each instance) ^{#3}
	jpcsto.ini	Agent Store service startup initialization file (for each instance) ^{#1}
	jpcsto.ini.model	Model file for the Agent Store service startup initialization file for logical host operation (for each instance) ^{#1}
	*.DAT	Data model definition file for logical host operation (for each instance) ^{#1}
<i>environment-directory</i> ^{#8} / <i>jp1pc/agt/store/instance-name/backup/</i>	--	Default database backup directory for logical host operation (for each instance) ^{#1}
<i>environment-directory</i> ^{#8} / <i>jp1pc/agt/store/instance-name/dump/</i>	--	Default database export directory for logical host operation (for each instance) ^{#1}
<i>environment-directory</i> ^{#8} / <i>jp1pc/agt/store/instance-name/import/</i>	--	Default database import directory for Store version 2.0 for logical host operation (for each instance) ^{#6}
<i>environment-directory</i> ^{#8} / <i>jp1pc/agt/store/instance-name/log/</i>	--	Storage directory for internal log files of the Agent Store service for logical host operation (for each instance) ^{#1}
<i>environment-directory</i> ^{#8} / <i>jp1pc/agt/store/instance-name/partial/</i>	--	Default database partial backup directory for Store version 2.0 for logical host operation (for each instance) ^{#6}
<i>environment-directory</i> ^{#8} / <i>jp1pc/agt/store/instance-name/STPD/</i>	--	Base directory for performance data of the PD record type for Store version 2.0 for logical host operation (for each instance) ^{#6}
<i>environment-directory</i> ^{#8} / <i>jp1pc/agt/store/instance-name/STPI/</i>	--	Base directory for performance data of the PI record type for Store version 2.0 for logical host operation (for each instance) ^{#6}

Directory name	File name	Description
<i>environment-directory</i> ^{#8} / <i>jp1pc/agt/store/instance-name</i> /STPL/	--	Base directory for performance data of the PL record type for Store version 2.0 for logical host operation (for each instance) ^{#6}
<i>environment-directory</i> ^{#8} / <i>jp1pc/auditlog/</i>	--	Default output directory for the action log files for logical host operation
	<i>jpcaudit</i> <i>n</i> ^{#9} .log	Action log file for logical host operation ^{#7}

Legend:

--: Not applicable

#1

This is created by the execution of the `jpccconf inst setup` command.

#2

This file is used internally by PFM - Agent for Enterprise Applications. Do not change or delete it.

#3

This is created when the Agent Store service is started.

#4

This is created when a CCMS Alert Monitor Command (PD_ALMX) record is collected.

#5

This is created when a System Log Monitor Command (PD_SLMX) record is collected.

#6

This is created when Store version 2.0 is used to configure the Store database.

#7

You can use the `jpccomm.ini` file to change the number of log files.

#8

The environment directory is on the shared disk that was specified when the logical host was created.

#9

n indicates a numeric value.

H. Migration Steps and Notes on Migration

This appendix describes how to upgrade your PFM - Agent for Enterprise Applications.

H.1 Upgrade installation

- You upgrade PFM - Agent for Enterprise Applications by overwriting the existing PFM - Agent for Enterprise Applications.

When PFM - Agent for Enterprise Applications is overwritten, the following items are updated automatically:

- Agent Store service's Store database file
- `ini` file (excluding the environment parameter files for system log information and CCMS Alert Information)
- Instance environment for PFM - Agent for Enterprise Applications

For details about migration from an old version of Performance Management (upgrading from 07-00 or earlier to 08-00), see the appendix in the *JPI/Performance Management Planning and Configuration Guide*.

Note

If an old version of PFM - Agent for Enterprise Applications is uninstalled in order to upgrade it, the performance data collected by that version is also deleted and becomes unavailable to the new version.

- If you are monitoring the system log information and CCMS Alert Information storage files using a file monitoring product, stop the file monitoring function before beginning.

H.2 Extracting the system log information and CCMS Alert Information

- If you change the size or output format of storage files, manually delete the existing storage and management files.
- The current settings in the environment parameter files for system log information and CCMS Alert Information are inherited during upgrading, including the existing instances.
- If sections and labels are added to the environment parameter file during upgrading, information about the added sections and labels is not applied to the environment parameter file. For details about the added sections and labels, see [Appendix L. Version Changes](#).
- If PFM - Agent for Enterprise Applications is upgraded from version 09-00 or earlier, the storage files will have the same output format as before (`WRAP1`).
- If PFM - Agent for Enterprise Applications is upgraded from version 09-00 or earlier and a new instance is configured or an environment parameter file is created from a sample environment parameter file, the items related to system log information and CCMS Alert Information storage files are set to the following default values:
 - Output format (`TYPE` label in the `EXTRACTFILE` section): `WRAP2`
 - File size (`SIZE` label in the `EXTRACTFILE` section): 10240 (kilobytes)

I. Version Compatibility

PFM - Agent has a data model version as well as a product version.

Because the data model is always upward compatible, report and alarm definitions created by an old version can be used with the new version of the data model.

The following table shows the correspondence among versions for PFM - Agent for Enterprise Applications.

Table I-1: Cross-reference table of PFM - Agent for Enterprise Applications versions

PFM - Agent for Enterprise Applications version	Data model version	Alarm table version for the monitoring template
06-70	3.0	6.70
07-00	4.0	7.00
08-00	5.0	8.00
09-00	5.0	09.00
10-00	5.0	10.00
10-51	5.0	10.00
11-00	5.0	10.00
12-00	5.0	10.00

For details about version compatibility, see the appendix in the *JPI/Performance Management Planning and Configuration Guide*.

J. Outputting Action Log Data

Performance Management action logs consist of historical information about actions that are linked with the alarm function for exceeded threshold values, such as system loading and start and stop of PFM services.

For example, action logs are output when PFM services start and stop, as well as when the connection status with PFM - Manager changes.

You can output action logs when the version of PFM - Manager or PFM - Base is 08-11 or later.

Action logs constitute a text file in CSV format. You can use them as analysis data by saving them periodically and processing them with a spreadsheet software program.

Output of action logs is set by `jpccomm.ini`. This appendix describes the information that is output as action logs by PFM - Agent and PFM - Base and how to make the settings for outputting action logs.

J.1 Types of events output to the action log

The table below lists and describes the types of events that are output to action logs and when action logs are output by PFM - Agent and PFM - Base. *Type of event* shows the identifiers used to classify the events that are output to action logs.

Table J–1: Types of events that are output to action logs

Type of event	Description	Timing of output by PFM - Agent and PFM - Base
StartStop	Event indicating the start and termination of software	<ul style="list-style-type: none">Start and stop of PFM servicesStart and end of the stand-alone mode
ExternalService	Event indicating the result of communication between JP1 products and external services Event indicating occurrence of an abnormal communication	Change in the status of the connection with PFM - Manager
ManagementAction	Event indicating execution of a program's important action Event indicating execution of an action based on another audit category	Execution of an automatic action

J.2 Format for saving the action log files

This subsection describes the format for saving the action log files.

Action logs are output to the default file (current output file). When this file becomes full, the action logs in the current output file are saved to a separate file (shift file).

To swap action log files:

1. Action logs are output sequentially to the current output file `jpcaudit.log`.
2. When the current output file becomes full, the action logs in that file are saved to a shift file.

The shift file name is the current output file name with a number appended to it. Each time the current output file becomes full, each shift file is renamed to *file-name-number* + 1. Therefore, an older file has a larger number at the end of the file name.

Example:

When the current output file `jpcaudit.log` becomes full, its contents are saved to the shift file `jpcaudit1.log`.

When the current output file becomes full again, its contents are moved to `jpcaudit1.log` and the existing shift file is renamed to `jpcaudit2.log`.

When the number of log files reaches the maximum value (as specified in the `jpccomm.ini` file), the oldest log file is deleted.

3. The current output file is initialized and new action logs are written.

Whether action logs are to be output, their output destination, and the maximum number of storage files is specified in the `jpccomm.ini` file. For details about making the settings in the `jpccomm.ini` file, see [J.4 Settings for outputting action log data](#).

J.3 Format of output action log data

Information about audit events is output to the Performance Management action logs. For action logs, one file is output for each host (physical and logical hosts). An action log's output destination host is as follows:

- When a service is executed: Action logs are output to the host where the service is running.
- When a command is executed: Action logs are output to the host that executed the command.

The following describes the output format, output destination, and output items for action logs.

(1) Output format

`CALFHM x.x, output-item-1=value-1, output-item-2=value-2, ..., output-item-n=value-n`

(2) Output destination

Table J–2: Default action log output directory

OS environment	Host environment	Default output directory
Windows	Physical host	<i>installation-folder</i> \auditlog\
	Logical host	<i>environment-directory</i> #\jplpc\auditlog\
Linux	Physical host	/opt/jplpc/auditlog/
	Logical host	<i>environment-directory</i> #/jplpc/auditlog/

#

The environment directory is on the shared disk that was specified when the logical host was created.

You can use the `jpccomm.ini` file to change the output destination of action logs. For details about how to make settings in the `jpccomm.ini` file, see [J.4 Settings for outputting action log data](#).

(3) Output items

There are two types of output items:

- Common output items
Output items common to all JP1 products that output action logs
- Fixed output items
Optional items that are output by the individual JP1 products that output action logs

(a) Common output items

The table below lists and describes the common output items and their values, including the items that are output by PFM - Manager.

Table J–3: Common output items for action logs

No.	Output item		Value	Description
	Item name	Output attribute name		
1	Common specification identifier	--	CALPFHM	Identifier indicating that this is the action log format
2	Common specification revision number	--	<i>x.x</i>	Revision number used for managing action logs
3	Sequence number	seqnum	<i>sequence-number</i>	Sequence number of action log records
4	Message ID	msgid	<i>KAVExxxx-x</i>	Product's message ID
5	Date and time	date	<i>YYYY-MM-DDThh:mm:ss.sssTZD#</i>	Output date, time, and time zone of the action log
6	Generated program name	progid	JP1PFM	Name of the program where the event occurred
7	Generated component name	compid	<i>service-ID</i>	Name of the component where the event occurred
8	Generated process ID	pid	<i>process-ID</i>	Process ID of the process where the event occurred
9	Generated location	ocp:host	<ul style="list-style-type: none"> • <i>host-name</i> • <i>IP-address</i> 	Location where the event occurred
10	Event type	ctgry	<ul style="list-style-type: none"> • StartStop • Authentication • ConfigurationAccess • ExternalService • AnomalyEvent • ManagementAction 	Category names used to classify the events that are output to action logs
11	Event result	result	<ul style="list-style-type: none"> • Success • Failure • Occurrence 	Result of the event
12	Subject identification information	subj:pid	<i>process-ID</i>	One of the following: <ul style="list-style-type: none"> • Process ID that is run by the user operation
		subj:uid	<i>account-identifier</i> (PFM user/JP1 user)	

No.	Output item		Value	Description
	Item name	Output attribute name		
12	Subject identification information	subj:euid	<i>effective-user-ID</i> (OS user)	<ul style="list-style-type: none"> • Process ID that caused the event • User name that caused the event • Identification information assigned to users on a 1:1 basis

Legend:

--: None

#

T indicates a separator in a date and time string.

ZD represents the time zone specifier. One of the following is output:

+hh:mm: Advanced from UTC by hh:mm

-hh:mm: Delayed from UTC by hh:mm

Z: Same as UTC

(b) Fixed output items

The table below lists and describes the fixed output items and their values, including the items that are output by PFM - Manager.

Table J–4: Fixed output items for action logs

No.	Output item		Value	Description
	Item name	Output attribute name		
1	Object information	obj	<ul style="list-style-type: none"> • <i>service-ID-of-PFM-Agent</i> • <i>user-name-added-or-deleted-or-updated</i> (PFM user) 	Operation target
		obj:table	<i>alarm-table-name</i>	
		obj:alarm	<i>alarm-name</i>	
2	Action information	op	<ul style="list-style-type: none"> • Start • Stop • Add • Update • Delete • Change Password • Activate (enable) • Inactivate (disable) • Bind • Unbind 	Action that caused the event
3	Permissions information	auth	<ul style="list-style-type: none"> • Administrator user Management • General user Ordinary • Windows Administrator 	Permissions of the user who performed the operation

No.	Output item		Value	Description
	Item name	Output attribute name		
3	Permissions information	auth	<ul style="list-style-type: none"> Linux SuperUser 	Permissions of the user who performed the operation
		auth:mode	<ul style="list-style-type: none"> PFM authentication mode pfm JPI authentication mode jpl OS user os 	Authentication mode of the user who performed the operation
4	Output source	outp:host	Host name of PFM - Manager	Host that output the action log
5	Instruction source	subjp:host	<ul style="list-style-type: none"> <i>name-of-logon-host</i> <i>name-of-executing-host</i> (only during execution of <code>jpctool alarm</code> command) 	Host that issued the operation instruction
6	Free description	msg	<i>message</i>	Message that is output in the event of an alarm and execution of automatic action

For the fixed output items, whether each output item exists depends on the output timing. The following subsections describe the message ID and fixed output items for each output timing.

■ Start and end of PFM services (StartStop)

- Output host: Host on which the corresponding service is running
- Output component: Each service that starts and stops

Item name	Attribute name	Value
Message ID	msgid	Start: KAVE03000-I Stop: KAVE03001-I
Action information	op	Start: Start Stop: Stop

■ Start and end of the stand-alone mode (StartStop)

- Output host: PFM - Agent host
- Output components: Agent Collector and Agent Store services

Item name	Attribute name	Value
Message ID	msgid	Start of the stand-alone mode: KAVE03002-I End of the stand-alone mode: KAVE03003-I

Note 1

Fixed output items are not output.

Note 2

When each service of PFM - Agent starts, it connects to the PFM - Manager host to perform tasks, such as registering node information and acquiring the most recent alarm definition information. If the service cannot connect to the PFM - Manager host, it starts (in the stand-alone mode) with only some of the functions enabled,

such as collection of operation information. KAVE03002-I is then issued to notify the user that the service has started in the stand-alone mode. The service attempts repeatedly at a specified interval to connect to the PFM - Manager host. When the service successfully registers node information and acquires definition information, it ends the stand-alone mode and issues KAVE03003-I. Output of KAVE03002-I and KAVE03003-I in the action logs indicates that PFM - Agent was running in an incomplete status.

■ **Change in the status of connection to PFM - Manager (ExternalService)**

- Output host: PFM - Agent host
- Output component: Agent Collector and Agent Store services

Item name	Attribute name	Value
Message ID	msgid	Transmission of an event to PFM - Manager failed (queuing started): KAVE03300-I Re-transmission of an event to PFM - Manager was completed: KAVE03301-I

Note 1

Fixed output items are not output.

Note 2

If transmission of an event to PFM - Manager fails, the Agent Store service starts queuing events. Events are then queued until three events have been queued. KAVE03300-I is output when event transmission first fails and queuing starts. When connection with PFM - Manager is restored and transmission of queued events is completed, KAVE03301-I is output. Output of KAVE03300-I and KAVE03301-I in action logs indicates the period during which events were not transmitted in real-time to PFM - Manager.

Note 3

The Agent Collector service normally sends events to PFM - Manager via the Agent Store service. If the Agent Store service is stopped for some reason, the Agent Collector service sends events to PFM - Manager directly. When transmission of events to PFM - Manager fails, KAVE03300-I is output (KAVE03301-I is not output because queuing is not started). This action log indicates that there are events that were not sent to PFM - Manager.

■ **Execution of automatic action (ManagementAction)**

- Output host: Host that executed the action
- Output component: Action Handler service

Item name	Attribute name	Value
Message ID	msgid	Creation of a command execution process was successful: KAVE03500-I Creation of a command execution process failed: KAVE03501-W Email transmission was successful: KAVE03502-I Email transmission failed: KAVE03503-W
Free description	msg	Command execution cmd= <i>executed-command-line</i> is output. Email transmission mailto= <i>destination-email-address</i> is output.

Note

KAVE03500-I is output when a command execution process is created successfully. Once this occurs, the results of checking command execution and the execution results are not output to the action logs.

(4) Output example

The following shows an output example of action logs:

```
CALFHM 1.0, seqnum=1, msgid=KAVE03000-I, date=2007-01-18T22:46:49.682+09:00,
progid=JP1PFM, compid=TA1host01, pid=2076,
ocp:host=host01, ctgry=StartStop, result=Occurrence,
subj:pid=2076,op=Start
```

J.4 Settings for outputting action log data

Use the `jpccomm.ini` file to specify the settings for outputting action logs. If you do not specify these settings, action logs will not be output. This subsection describes the settings and procedure for outputting action logs.

(1) How to specify settings

To specify settings for outputting action logs:

1. Stop all PFM services on the host.
2. Edit the `jpccomm.ini` file using a program such as a text editor.
3. Save the `jpccomm.ini` file and then close it.

(2) Details of the `jpccomm.ini` file

This subsection describes the `jpccomm.ini` file.

(a) Storage directory

Table J–5: `jpccomm.ini` file storage directory

OS environment	Host environment	Storage directory
Windows	Host environment	<i>installation-folder</i>
	Logical host	<i>environment-directory</i> [#] \jp1pc\
Linux	Host environment	<i>/opt/jp1pc/</i>
	Logical host	<i>environment-directory</i> [#] /jp1pc/

#

The environment directory is on the shared disk that was specified when the logical host was created.

(b) Format

The following information is defined in the `jpccomm.ini` file:

- Whether action logs are to be output
- Action log output destination
- Number of action log files to be saved
- Size of the action log files

The specification format is as follows:

`"item-name"=value`

The following table lists and describes the settings.

Table J–6: Settings and their initial values that are specified in the jpccomm.ini file

No.	Item	Description
1	[Action Log Section]	Specifies the section name. This item cannot be changed.
2	Action Log Mode	<p>Specifies whether action logs are to be output. This item is mandatory.</p> <ul style="list-style-type: none"> Initial value 0 (Do not output) Permitted values 0 (Do not output), 1 (Output) <p>If any other value is specified, an error message is issued and action logs are not output.</p>
3	Action Log Dir	<p>Specifies the action log output destination.</p> <p>In a logical host environment, specify a directory on the shared disk. If the specified directory is not on the shared disk, action logs are output to each physical host that constitutes the logical host.</p> <p>If the specified path exceeds the maximum length or access to the specified directory fails, an error message is output to the common log and action logs are not output.</p> <ul style="list-style-type: none"> Initial value None Value assumed when the item is omitted (default) <ul style="list-style-type: none"> In Windows <i>installation-folder</i>\auditlog\ In Windows (for logical host operation) <i>environment-directory</i>#\jplpc\auditlog\ In Linux /opt/jplpc/auditlog/ In Linux (for logical host operation) <i>environment-directory</i>#/jplpc/auditlog/ <p># The environment directory is on the shared disk that was specified when the logical host was created.</p> <ul style="list-style-type: none"> Permitted values Character strings from 1 to 185 bytes in size
4	Action Log Num	<p>Specifies the maximum number of log files. This is the total number of the current output file and the shift files.</p> <ul style="list-style-type: none"> Initial value None Value assumed when the item is omitted (default) 5 Permitted values Integer in the range from 2 to 10 <p>If a nonnumeric character is specified, an error message is output and 5 is set as the default. If the specified value is outside the permitted range, an error message is output and the integer in the range from 2 to 10 that is closest to the specified value is set.</p>
5	Action Log Size	<p>Specifies the log file size in kilobytes.</p> <ul style="list-style-type: none"> Initial value None Value assumed when the item is omitted (default) 2048 Permitted values

No.	Item	Description
5	Action Log Size	<p>Integer in the range from 512 to 2,096,128.</p> <p>If a nonnumeric character is specified, an error message is output and the default value of 2,048 is set.</p> <p>If the specified value is outside the permitted range, an error message is output and the integer in the range from 512 to 2,096,128 that is closest to the specified value is set.</p>

K. Working with JP1/SLM

PFM - Agent for Enterprise Applications can enhance its monitoring capabilities by working with JP1/SLM.

To achieve monitoring in JP1/SLM, PFM - Agent for Enterprise Applications provides PFM - Manager with the default monitoring items for JP1/SLM.

Table K–1: Default monitoring items provided to PFM - Manager by PFM - Agent for Enterprise Applications

Name displayed in JP1/SLM	Description	Record (record ID)	Key (PFM - Manager name)	Field name (PFM - Manager name)
Wait time at the front end for a request	Average time the user waits until the user's request is processed at the front end (response time, network transfer time, and front-end processing time) (milliseconds).	WorkLoad Summary Interval (PI)	--	FrontendResponseTime (FRONTEND_RESPONSE_TIME)
Dialog step processing time	Indicates the time required for processing dialog steps. This value includes the database processing time, but not the network transfer time nor the front-end processing time. The value displayed here is the average value for dialog steps (milliseconds).	WorkLoad Summary Interval (PI)	--	ResponseTime (RESPONSE_TIME)
Response time of standard transactions	Response time of standard transactions. These standard transactions simulate the normal loads of transactions by accessing data in the database and executing a series of ABAP function modules (milliseconds).	WorkLoad Summary Interval (PI)	--	ResponseTime:StandardTran. (RESPONSE_TIME_STANDARD_TRANSACTION)
Database request time	Average time required for processing logical database requests (milliseconds).	WorkLoad Summary Interval (PI)	--	DBRequestTime (DB_REQUEST_TIME)
Number of dialog steps	Average number of dialog steps per minute.	WorkLoad Summary Interval (PI)	--	DialogSteps (DIALOG_STEPS)
Number of users logged on	Number of users that are logged on.	WorkLoad Summary Interval (PI)	--	UsersLoggedIn (USERS_LOGGED_IN)

These default monitoring items do not require any setup in PFM - Agent because they are automatically registered to PFM - Manager when PFM - Manager is installed.

However, the setup command must be executed in PFM - Manager if the data model version of PFM - Agent in use is not included in the *Release Notes* for PFM - Manager.

L. Version Changes

L.1 Changes in version 12-00

- The following OS is now supported:
 - Windows Server 2016
- The following OS is no longer supported:
 - Windows Server 2008 R2
- The remote monitoring of SAP systems is now possible.

L.2 Changes in version 11-00

(1) Changes in manual 3021-3-A58-10(E)

- Linux is now supported.

(2) Changes in manual 3021-3-A58(E)

- The default value for `EXTPWD` (*whether to use extended passwords*), a setting for instance setup, was changed from N (do not use) to Y (use).
- All text relating to UNIX was deleted.

L.3 Changes in version 10-51

- The default value for `EXTPWD` (*whether to use extended passwords*), a setting for instance setup, was changed from N (do not use) to Y (use).
- The following messages were added:
KAVF14140-E, KAVF14184-E, KAVF14185-E, KAVF14186-E, KAVF14190-E, KAVF14285-E,
KAVF14286-E, KAVF14287-E, KAVF14288-E
- The following messages have been changed:
KAVF14122-E, KAVF14221-E

L.4 Changes in version 10-00

- PFM - Agent for Enterprise Applications can now be linked with JP1/ITSLM. The default monitoring items are listed below:
 - `FRONTEND_RESPONSE_TIME`
 - `RESPONSE_TIME`
 - `RESPONSE_TIME_STANDARD_TRAN`
 - `DB_REQUEST_TIME`

- DIALOG_STEPS
- USERS_LOGGED_IN
- The storage files for system log information and CCMS Alert Information can now be output either in the WRAP1 or WRAP2 format.
If a new instance environment is configured in version 10-00 or later or an environment parameter file is created from a sample environment parameter file, the default output format is WRAP2.
- The default size of system log information and CCMS Alert Information storage files has been changed from 1,024 to 10,240 kilobytes.
- The following labels have been added to the environment parameter file for system log information and CCMS Alert Information:

Section	Label
EXTRACTFILE	TYPE
EXTRACTFILE	NUM

- The version of the alarm table in the monitoring template has been changed from 9.00 to 10.00.
- The following messages have been added:
KAVF14280-W, KAVF14281-W

L.5 Changes in version 09-00

- The name *solution set* has been changed to *monitoring template*.
- The version of the alarm tables for the monitoring template has been changed from 8.00 to 09.00.
- The following messages have been added:
KAVF14152-E, KAVF14178-W, KAVF14179-W
- Due to the addition of commands with a new format that is compatible with the commands for version 08-11 or earlier, the commands for version 09-00 or later are now referred to as follows:
Commands for 09-00 or later (commands for 08-11 or earlier)
- The following alarm tables have been added to the monitoring template:
 - PFM SAP System Template Alarms 09.00
 - PFM SAP System Template Alarms [Background Processing] 09.00
 - PFM SAP System Template Alarms [Background Service] 09.00
 - PFM SAP System Template Alarms [Dialog Utilization] 09.00
- The following alarms have been added to the monitoring template:
 - SystemWideQueue
 - ServerSpecificQueue
 - Utilization %
 - QueueLength %

M. Reference Material for this Manual

M.1 Related publications

This manual is part of a related set of manuals. The manuals in the set are listed below (with the manual numbers):

Manuals associated with JP1/Performance Management:

- *JP1 Version 12 Performance Management: Getting Started* (3021-3-D75(E))
- *JP1 Version 12 JP1/Performance Management Planning and Configuration Guide* (3021-3-D76(E))
- *JP1 Version 12 JP1/Performance Management User's Guide* (3021-3-D77(E))
- *JP1 Version 12 JP1/Performance Management Reference* (3021-3-D78(E))

Manuals associated with JP1:

- *JP1 Version 12 JP1/Base User's Guide* (3021-3-D65(E))
- *JP1 Version 11 JP1/Service Level Management Description, User's Guide, Reference and Operator's Guide* (3021-3-A32(E))
- *Job Management Partner 1/Software Distribution Manager Description and Administrator's Guide* (3000-3-841(E))
- *Job Management Partner 1/Software Distribution SubManager Description and Administrator's Guide* (3020-3-L42(E)), for UNIX systems
- *Job Management Partner 1/Software Distribution Administrator's Guide Volume 1* (3020-3-S81(E)), for Windows systems
- *Job Management Partner 1/Software Distribution Client Description and User's Guide* (3020-3-S85(E)), for UNIX systems

M.2 Conventions: Abbreviations

This manual uses the following abbreviations for the names of Hitachi products and other products:

Abbreviation		Full name or meaning
IPF		Itanium(R) Processor Family
JP1/IM	JP1/IM - Manager	JP1/Integrated Management - Manager
		JP1/Integrated Management 2 - Manager
	JP1/IM - View	JP1/Integrated Management - View
		JP1/Integrated Management 2 - View
JP1/SLM	JP1/SLM - Manager	JP1/Service Level Management - Manager
	JP1/SLM - UR	JP1/Service Level Management - User Response

Abbreviation		Full name or meaning	
JP1/Software Distribution		Job Management Partner 1/ Software Distribution Client	
		Job Management Partner 1/ Software Distribution Manager	
		Job Management Partner 1/ Software Distribution SubManager	
Linux	Linux 6 (x64)		Red Hat Enterprise Linux(R) Server 6.1 (64-bit x86_64) or later
	Linux 7		Red Hat Enterprise Linux(R) Server 7.1 or later
	Oracle Linux	Oracle Linux 6 (x64)	Oracle Linux(R) Operating System 6.1 (x64) or later
		Oracle Linux 7	Oracle Linux(R) Operating System 7.1 or later
	SUSE Linux	SUSE Linux 12	SUSE Linux(R) Enterprise Server 12
Performance Management		JP1/Performance Management	
PFM - Agent	PFM - Agent for Enterprise Applications		JP1/Performance Management - Agent Option for Enterprise Applications
	PFM - Agent for JP1/AJS	PFM - Agent for JP1/ AJS2	JP1/Performance Management - Agent Option for JP1/AJS2
	PFM - Agent for Microsoft SQL Server		JP1/Performance Management - Agent Option for Microsoft(R) SQL Server
	PFM - Agent for Oracle		JP1/Performance Management - Agent Option for Oracle
	PFM - Agent for Platform	PFM - Agent for Platform(UNIX)	JP1/Performance Management - Agent Option for Platform (for UNIX systems)
		PFM - Agent for Platform(Windows)	JP1/Performance Management - Agent Option for Platform (for Windows systems)
	PFM - Agent for Service Response		JP1/Performance Management - Agent Option for Service Response
	PFM - Agent for Virtual Machine		JP1/Performance Management - Agent Option for Virtual Machine
PFM - Base		JP1/Performance Management - Base	
PFM - Manager		JP1/Performance Management - Manager	
PFM - RM	PFM - RM for Microsoft SQL Server		JP1/Performance Management - Remote Monitor for Microsoft(R) SQL Server
	PFM - RM for Oracle		JP1/Performance Management - Remote Monitor for Oracle

Abbreviation		Full name or meaning
PFM - RM	PFM - RM for Platform	JP1/Performance Management - Remote Monitor for Platform
	PFM - RM for Virtual Machine	JP1/Performance Management - Remote Monitor for Virtual Machine
PFM - Web Console		JP1/Performance Management - Web Console
SAP NetWeaver		SAP NetWeaver(R)

- PFM - Manager, PFM - Agent, PFM - Base, PFM - Web Console, and PFM - RM may be referred to collectively as *Performance Management*.
- HP-UX, Solaris, AIX, and Linux may be referred to collectively as *UNIX*.

M.3 Acronyms

This manual also uses the following abbreviations:

Abbreviation	Full name or meaning
BAPI	Business Application Programming Interface
CCMS	Computer Center Management System
EST	Eastern Standard Time
IPF	Itanium (R) Processor Family
MTE	Monitoring Tree Element
ODBC	Open Database Connectivity
RFC	Remote Function Call
UTC	Coordinated Universal Time

M.4 Format of product names, service IDs, and service keys in this manual

In Performance Management 09-00 or later, the service ID and service key can be displayed in the product name when the product name display functionality is enabled.

Identifier	Product name display functionality	
	Disabled	Enabled
Service ID	MS1instance name[host name]	<i>instance-name [host-name] <SAP System> (Store)</i>
	MA1instance name[host name]	<i>instance-name [host-name] <SAP System> (Store)</i>
Service key	agtm	EAP

This manual uses the format that is used when the product name display functionality is enabled.

Note that the product name display functionality can be enabled when both of the following conditions exist:

- The version of the prerequisite program (PFM - Manager or PFM - Base) on the same device as PFM-Agent is 09-00 or later.
- The versions of PFM - Web Console and the PFM - Manager to which it connects are 09-00 or later.

M.5 Performance Management installation folders

The default installation folders for the Windows version of Performance Management are as follows:

Default installation folder for PFM - Base

```
system-drive\Program Files (x86)\Hitachi\jplpc
```

In this manual, the PFM - Base installation folder is referred to as the *installation folder*.

Default installation folder for PFM - Manager

```
system-drive\Program Files (x86)\Hitachi\jplpc
```

Default installation folder for PFM - Web Console

```
system-drive\Program Files (x86)\Hitachi\jplpcWebCon
```

The default installation directories for the Linux version of Performance Management are as follows:

Default installation directory for PFM - Base

```
/opt/jplpc
```

Default installation directory for PFM - Manager

```
/opt/jplpc
```

Default installation directory for PFM - Web Console

```
/opt/jplpcwebcon
```

M.6 Conventions: KB, MB, GB and TB

This manual uses the following conventions:

- 1 KB (kilobyte) is 1,024 bytes.
- 1 MB (megabyte) is 1,024² bytes.
- 1 GB (gigabyte) is 1,024³ bytes.
- 1 TB (terabyte) is 1,024⁴ bytes.

N. Glossary

ASCS instance (ABAP Central Services)

An SAP system instance. This is a unit of a cluster configuration when SAP NetWeaver 7.0 or later is used to run PFM - Agent for Enterprise Applications.

This instance includes an SAP system's message server and enqueue server.

It does not have a dialog server.

CCMS alert information extraction function

A PFM - Agent for Enterprise Applications function that extracts warnings (alert information) occurring in the Alert Monitor of the computer center management system (CCMS).

central instance

An SAP system instance with a dialog service to which PFM - Agent for Enterprise Applications connects. When SAP NetWeaver 2004 or earlier is used to run PFM - Agent for Enterprise Applications, the central instance is a unit of a cluster configuration.

This is also called a *primary application server instance*.

database ID

Identifier of the database that is added to each of PFM - Agent's records. The database ID indicates the types of records that are stored in the corresponding database. The following are the database IDs:

- PI: Indicates a database for records of the PI record type
- PD: Indicates a database for records of the PD record type

dialog instance

An SAP system instance with a dialog service to which PFM - Agent for Enterprise Applications connects.

This is also called an *application server instance*.

Any application server instances other than the primary application server instances are also called the *additional application server instances*.

extended password

A password that is supported by an SAP system based on SAP NetWeaver 7.0 or later. In such an SAP system, the length of a password has been extended from 8 to 40 characters and the rules for alphabetic characters in a password have been changed from upper-case-only to case-sensitive.

JP1/SLM

A software product that supports the maintenance of service levels by monitoring business systems in terms of their performance as experienced by the service users.

By linking PFM - Agent for Enterprise Applications with JP1/SLM, its capabilities of monitoring operating statuses can be enhanced.

monitor information collection function

A function for collecting SAP system monitor information according to user definitions and storing it as user-defined records for PFM - Agent for Enterprise Applications.

monitoring template

Predefined alarms and reports provided by PFM - Agent. A monitoring template simplifies preparations for monitoring the operating status of PFM - Agent because complex definitions do not have to be created.

Performance Management

A collective name for a group of software programs that are used to monitor and analyze issues related to system performance. Performance Management consists of the following five program products:

- PFM - Manager
- PFM - Web Console
- PFM - Base
- PFM - Agent
- PFM - RM

RFC

An SAP interface for communication between SAP systems.

SAP system

An ERP package system provided by SAP AG.

service ID

A unique identifier that is added to each Performance Management program service. When a command is used to check the configuration of the Performance Management system or to back up an individual agent's performance data, this Performance Management program service ID is specified in the command.

The format of the service ID depends on the settings of the product name display function. For details, see the chapter that describes the functions of Performance Management in the *JPI/Performance Management Planning and Configuration Guide*.

system log information extraction function

A PFM - Agent for Enterprise Applications function that extracts log information (system log) on the events and errors that occur in the SAP system. A system log is created for each application server.

WRAP1 format

A file format in which, when the amount of data in the file reaches a specified value, new data is overwritten starting from the beginning of the file.

There is a header line of management information at the beginning of storage files for system log information and CCMS Alert Information in PFM - Agent for Enterprise Applications. Only one WRAP1-format file can be used for any particular purpose.

WRAP2 format

A file format in which, when the amount of data in the file reaches a specified value, data is first deleted from the file and then new data is written starting from the beginning of the file.

In PFM - Agent for Enterprise Applications, the system log information and CCMS Alert Information can be stored in multiple WRAP2-format files.

Index

A

- ABAP buffer 270
- abbreviations defined 435
- action 20
- action log
 - format for saving 423
 - format of output 424
 - outputting 423
 - settings for outputting 429
 - types of events output to 423
- Agent Collector service properties 402
- Agent Store service properties 399
- alarms 20
 - easily defining 21
 - format used to explain 183
 - list of 184
- alarm table 20
- alias name 30, 49
- ASCS instance (ABAP Central Services) 439
- authorization, required 40, 60, 101, 113
 - for user to establish RFC connection with function modules (S_RFC) 40, 60, 101, 113
 - for using external management interfaces (S_XMI_PROD) 40, 60, 101, 113

B

- Background Processing (PI_BTCP) record 259
- Background Processing SystemWideQueue report 240
- Background Service (PI_BTC) record 261
- Background Service ServerSpecificQueue report 241
- Background Service Utilization % report 242
- backup 85
- baseline, selecting 24
- binding 21
- Buffer - CUA alarm 186
- Buffer - FieldDescri alarm 187
- Buffer - GenericKey alarm 188
- Buffer - InitialReco alarm 189
- Buffer - Program alarm 190
- Buffer - Screen alarm 191
- Buffer - ShortNameTA alarm 192
- Buffer - SingleRecor alarm 193
- Buffer - TableDefini alarm 194

C

- CCMS alert, monitoring 28
- CCMS alert information 21
 - extracting 21, 154
 - extraction function 152, 439
 - monitoring 28
- CCMS Alert Monitor Command (PD_ALMX) record 263
- CCMS monitoring architecture 174
- central instance 439
- changes in
 - version 09-00 434
 - version 10-00 433
 - version 10-51 433
 - version 11-00 433
 - version 12-00 433
- cluster system
 - installation and setup (Linux) 108
 - installation and setup (Windows) 96
 - installing in 33, 52
 - operation in 90
 - setting up in 33, 52
- commands
 - format used to explain 298
 - list of 300
 - notes on 299
 - specification method of 298
- COMMAND section 146, 169
- common message log 369, 370
- CONNECT section 139, 145, 162, 167
- conventions
 - abbreviations 435
 - diagrams 7
 - fonts and symbols 8
 - mathematical expressions 9
- CUA buffer 270

D

- database ID 439
- data model 20, 244
- data types, list of 251
- default record retention period
 - for PI record type 82
 - in Store version 2.0 81
- diagram conventions 7

- dialog instance 439
- Dialog ResponseTime alarm 195
- Dialog ResponseTime report 210
- Dialog ResponseTime Status report 211
- Dialog ResponseTime Trend (Multi-Agent) report 214
- Dialog ResponseTime Trend report 212, 213
- Dialog Service (PI_DIA) record 265
- Dialog Utilization % report 215
- directories
 - list of 411
 - list of (Linux) 416
- disk space requirements 392
 - for cluster use 392
- drilldown report
 - field level 205
 - report level 205
- dynpro buffer 270

E

- Enqueue Service (PI_ENQ) record 268
- environment parameters file 135, 157
- error handling procedure 356
- Extended Memory alarm 196
- extended password 439
- EXTRACTFILE section 137, 148, 159, 171

F

- failover
 - processing at 93
 - when error occurs on PFM - Agent host 93
- field description buffer 270
- field ID 305, 312
- fields 20, 205
 - list of ODBC key 247
 - values stored in 252
- files
 - list of 411
 - list of (Linux) 416
 - list of (Windows) 411
- firewall passage direction 397
- folders, list of (Windows) 411
- font conventions 8
- FORMAT section 138, 148, 161, 170
- FTAB buffer 270

G

- generic key buffer 270
- generic table buffer 270
- glossary 439

H

- Heap Memory alarm 197
- historical report 19

I

- identifiers, list of 394
- initial record buffer 270
- instance environment
 - canceling setup of 69, 71, 120, 122
 - settings for updating 82
 - settings for updating (cluster system) 125
 - setting up 40, 60
- IP address, setting 30, 49
- IREC buffer 270

J

- JP1/SLM 439
 - working with 432
- jpccbctrl config command 75
- jpgcras command 383
- jpgcsto.ini file
 - editing 79
 - editing, to change settings 77
 - preparation before editing 78
 - settings in 77
- jr3alget command 301
- jr3slget command 308

K

- kernel parameter 393

L

- LANG environment variable, specifying 56
- list of
 - port numbers 397
 - processes 395
- log file size, changing 44, 64, 117

M

- manual

- how to view 89
- setting for using Web browser to reference 88
- setup procedure for referencing 88
- mathematical expression conventions 9
- memory requirements 392
- menu buffer 270
- messages 314, 323
 - format of 315
 - format used to explain 316
 - output destination of 317
 - output format of 315
 - output to syslog 321
 - output to Windows event log 321
- migration
 - notes on 421
 - steps 421
- monitor 174
- monitor information
 - collecting 173
 - collecting SAP system's 21
 - overview of collecting 174
 - settings for collecting 175
- monitor information collection function 440
- monitoring
 - buffer for menu information 26
 - CCMS alert 28
 - CCMS alert information 28
 - database request time 25
 - dialog response time 25
 - expansion memory use rate in SAP memory 27
 - Generic key buffer for table data 26
 - heap area use rate in SAP memory 27
 - load status in entire SAP system 25
 - number of work processes that are in PRIV mode 27
 - paging area use rate in SAP memory 27
 - program buffer 26
 - roll area use rate in SAP memory 28
 - SAP buffer 25
 - SAP memory 27
 - SAP system log 28
 - SingleRecord buffer for table data 27
 - system log 28
- monitoring template 21, 181, 182, 440
 - overview of 182
- monitor name, setting 175
- monitor set 174
- monitor set name, setting 175

N

- nametab buffer 270
- network environment setup 30, 49
- network setting, specifying 43, 63, 117
- Notes on Operating 177
- Notes on the collection base time 178
- Notes on the SAP system time zone 179
- NTAB buffer 270

O

- operation status log 369
- Option section 140, 163, 172
- Option section 150
- OS, supported 30, 49
- OS user permission required for installation 31, 50

P

- Paging Area alarm 198
- parameter, kernel 393
- partial table buffer 270
- passage direction, firewall 397
- password, characters permitted for 40, 60, 101, 113
- PD 290
- PD_ALMX 263
- PD_SLMX 282
- PD_SRV 275
- PD record type 20
- performance data
 - changing storage location of 44, 64, 75, 117
 - changing storage location of (cluster system) 125
 - collecting according to its characteristics 20
 - of SAP system, collecting 19
 - saving 20
 - settings for collecting 176
- performance information 174
- Performance Management 440
 - detecting problems within 389
 - system error recovery 390
- Performance Management program 33, 52
 - installing 36, 55
 - installing multiple, on same host 46, 65
 - setting up multiple, on same host 46, 65
- performance monitoring
 - about 24
 - example of 25
 - purpose of 24

- PFM - Agent for Enterprise Applications
 - backing up 85
 - backing up (cluster system) 126
 - canceling setup (Linux) 71
 - canceling setup (Linux cluster system) 122
 - canceling setup (Windows) 68
 - canceling setup (Windows cluster system) 120
 - changing operation method for 75
 - changing operation method for (cluster system) 125
 - changing system configuration 74
 - changing system configuration (cluster system) 124
 - checking before installing (Linux) 49
 - checking before installing (Windows) 30
 - checking before setting up (Linux) 49
 - checking before setting up (Windows) 30
 - configuration (cluster system) 91
 - copying setup files for 38, 58
 - features of 19
 - installation flow (Linux) 53
 - installation flow (Windows) 34
 - installation procedure (Linux) 55
 - installation procedure (Windows) 35
 - installing 29
 - installing (Linux) 49
 - installing (Windows) 30
 - Library application procedure 37, 56
 - notes about installation and setup (Linux) 65
 - notes about installation and setup (Windows) 45
 - notes before canceling setup (Linux) 71
 - notes before canceling setup (Windows) 68
 - notes before uninstalling (Linux) 71
 - notes before uninstalling (Windows) 68
 - overview of 18
 - properties of 399
 - registering to PFM - Manager and PFM - Web Console 37, 57
 - restoring 85
 - restoring (cluster system) 126
 - setting up 29
 - setting up (Linux) 49
 - setting up (Windows) 30
 - setup flow (Linux) 53
 - setup flow (Windows) 34
 - setup procedure (Linux) 56
 - setup procedure (Windows) 37
 - specifying connection-target PFM - Manager 44, 64, 118
 - uninstallation procedure (Linux) 72
 - uninstallation procedure (Windows) 70
 - uninstalling (Linux) 71
 - uninstalling (Linux cluster system) 122
 - uninstalling (Windows) 68
 - uninstalling (Windows cluster system) 120
 - unsetup procedure (Linux) 71
 - unsetup procedure (Windows) 69
- PFM - Manager failure
 - action to be taken for 94
 - effect of 94
- PI 293
- PI_BTC 261
- PI_BTCP 259
- PI_BUFFER 270
- PI_DIA 265
- PI_ENQ 268
- PI_MEM 277
- PI_SPO 280
- PI_UMP 288
- PI_UPD1 284
- PI_UPD2 286
- PI record type 20
- port numbers
 - list of 397
 - setting 31, 50
- presentation buffer 270
- Process Detail report 216
- processes, list of 395
- Process Overview Status report 217
- program
 - installation order for 36, 55
 - required 31, 50
 - that can be monitored 33, 52
- program buffer 270
 - monitoring 26
- properties
 - of Agent Collector service 402
 - of Agent Store service 399
- PXA buffer 270

Q

QueueLength % alarm 203

R

R/3 executable buffer 270

- R/3 GUI buffer 270
- real host name 30, 49
- real-time report 19
- record creation result when data cannot be acquired 255
- records 20, 205, 243
 - format used to explain 245
 - list of 257
 - notes on 255
- record type
 - PD 20
 - PI 20
 - Product Detail 20
 - Product Interval 20
- related publications 435
- reports 19
 - easily defining 21
 - folder organization of 206
 - format used to explain 205
 - list of 208
- required program 31, 50
- requirements
 - disk space 392
 - memory 392
- response time 25
 - records and fields related to 25
- restoration 86
 - Store version 1.0 from 2.0 81
- RFC 440
- Roll Area alarm 199
- SAP Buffer Summary (PI_BUFF) record 270
- SAP Instance Summary (PD_SRV) record 275
- SAP memory
 - monitoring 27
 - monitoring expansion memory use rate in 27
 - monitoring heap area use rate in 27
 - monitoring paging area use rate in 27
 - monitoring roll area use rate in 28
 - records and fields related to 27
- SAP Memory Detail report 232
- SAP Memory Summary (PI_MEM) record 277
- SAP Memory Used report 233
- SAP Memory Used Status report 234
- SAP Memory Used Trend report 235, 236
- SAP NetWeaver 7.0 or later
 - Linux 108, 122
 - Windows 96, 120
- SAP system 25, 440
 - reporting problems in operations of 20
- SAP system log, monitoring 28
- SAP user that is to be used by PFM - Agent for Enterprise Applications, creating 39, 59
- screen buffer 270
- ServerSpecificQueue alarm 201
- service ID 440
- setup command, executing
 - at PFM - Manager host 39, 59
 - at PFM - Web Console host 39, 59, 100
- short nametab buffer 270
- short NTAB buffer 270
- single record buffer 270
- SNTAB buffer 270
- Spool Service (PI_SPO) record 280
- status management function 389
- Store database 20
 - fields added only when data is stored in 254
- summary rule 248
- supported OS 30, 49
- symbol conventions 8
- symbols used to explain command syntax 298
- syntax conventions 9
- system estimates before configuration 392
- system log 369
 - monitoring 28
- system log information 21
 - extracting 132
 - extracting SAP system's 21

S

- SAP buffer
 - monitoring 25
 - records and fields related to 25
- SAP Buffer Detail (CUA) report 218
- SAP Buffer Detail (FieldDescription) report 219
- SAP Buffer Detail (GenericKey) report 220
- SAP Buffer Detail (InitialRecords) report 221
- SAP Buffer Detail (Program) report 222
- SAP Buffer Detail (Screen) report 223
- SAP Buffer Detail (ShortNameTAB) report 224
- SAP Buffer Detail (SingleRecord) report 225
- SAP Buffer Detail (TableDefinition) report 226
- SAP Buffer Hitratio report 227
- SAP Buffer Hitratio Status report 228
- SAP Buffer Hitratio Trend report 230, 231

extraction function 129, 440
System Log Monitor Command (PD_SLMX) record 282
SystemWideQueue alarm 200

T

TABL 270
table buffer 270
table DDNTF 270
table DDNTT 270
table definition buffer 270
TABLP 270
TARGET section 148, 159, 170
trace log 370
TRACE section 139, 147, 161, 169
troubleshooting 358

- data to be collected during 372
- data to be collected in Linux environment during 377
- how to collect data during 383
- how to collect data in Linux environment during 386
- list of log files and directories to be collected during 370
- log information to be collected during 369
 - related to alarm definition 363
 - related to collection and management of performance data 364
 - related to command execution 362
 - related to other problems 368
 - related to report definition 363
 - related to setup and service startup 358
- type of log information to be collected during 369

TTAB buffer 270

U

uninstalling 121, 123
Update1 Service (PI_UPD1) record 284
Update2 Service (PI_UPD2) record 286
updating

- from Store version 1.0 to 2.0 81
- Store version to 2.0 80
- Store version to 2.0 (cluster system) 125

upgrading 46, 66
User defined Monitor (Perf.) (PI_UMP) record 174, 288
UsersLoggedIn Trend (Multi-Agent) report 239
UsersLoggedIn Trend report 237, 238
user type 39, 59, 100, 112
Utilization %

alarm for monitoring average usage of background work processes 202
alarm for monitoring average usage of dialog processes 204

V

version changes 433
version compatibility 422

W

wildcard character 298
WorkLoad Summary Interval (PI) record 293
Work Process Summary (PD) record 290
WRAP1 format 440
WRAP2 format 440

 **Hitachi, Ltd.**

6-6, Marunouchi 1-chome, Chiyoda-ku, Tokyo, 100-8280 Japan
