

JP1 Version 11

**JP1/Performance Management - Agent Option for
Microsoft(R) SQL Server**

3021-3-A55-20(E)

Notices

■ Relevant program products

JP1/Performance Management - Manager (For Windows Server 2008 R2, Windows Server 2012, Windows Server 2012 R2, Windows Server 2016):

P-2A2C-AABL JP1/Performance Management - Manager version 11-50

The above product includes the following:

P-CC2A2C-5ABL JP1/Performance Management - Manager version 11-50

P-CC2A2C-5RBL JP1/Performance Management - Web Console version 11-50

JP1/Performance Management - Manager (For CentOS 6.1 or later (x64), CentOS 7.1 or later, Linux 6.1 or later (x64), Linux 7.1 or later, Oracle Linux 6.1 or later (x64), Oracle Linux 7.1 or later, SUSE Linux 12):

P-812C-AABL JP1/Performance Management - Manager version 11-50

The above product includes the following:

P-CC812C-5ABL JP1/Performance Management - Manager version 11-50

P-CC812C-5RBL JP1/Performance Management - Web Console version 11-50

JP1/Performance Management - Manager (For AIX V6.1, AIX V7.1, AIX V7.2):

P-1M2C-AABL JP1/Performance Management - Manager version 11-50

The above product includes the following:

P-CC1M2C-5ABL JP1/Performance Management - Manager version 11-50

P-CC1M2C-5RBL JP1/Performance Management - Web Console version 11-50

JP1/Performance Management - Agent Option for Microsoft(R) SQL Server (For Windows Server 2008 R2, Windows Server 2012, Windows Server 2012 R2, Windows Server 2016):

P-2A2C-AEBL JP1/Performance Management - Agent Option for Microsoft(R) SQL Server version 11-50

The above product includes the following:

P-CC2A2C-AJBL JP1/Performance Management - Base version 11-50

P-CC2A2C-FEBL JP1/Performance Management - Agent Option for Microsoft(R) SQL Server version 11-50

These products include the parts developed under licenses from other companies.

■ Export restrictions

If you export this product, please check all restrictions (for example, Japan's Foreign Exchange and Foreign Trade Law, and USA export control laws and regulations), and carry out all required procedures.

If you require more information or clarification, please contact your Hitachi sales representative.

■ Trademarks

HITACHI, Job Management Partner 1, JP1 are either trademarks or registered trademarks of Hitachi, Ltd. in Japan and other countries.

AMD, AMD Opteron, and combinations thereof, are trademarks of Advanced Micro Devices, Inc.

Hyper-V is either a registered trademark or a trademark of Microsoft Corporation in the United States and/or other countries.

IBM, AIX are trademarks of International Business Machines Corporation, registered in many jurisdictions worldwide.

IBM, DB2 are trademarks of International Business Machines Corporation, registered in many jurisdictions worldwide.

IBM, DB2 Universal Database are trademarks of International Business Machines Corporation, registered in many jurisdictions worldwide.

IBM, Domino are trademarks of International Business Machines Corporation, registered in many jurisdictions worldwide.

IBM, Lotus are trademarks of International Business Machines Corporation, registered in many jurisdictions worldwide.

Internet Explorer is either a registered trademark or trademark of Microsoft Corporation in the United States and/or other countries.

Itanium is a trademark of Intel Corporation in the United States and other countries.

Linux(R) is the registered trademark of Linus Torvalds in the U.S. and other countries.

Microsoft is either a registered trademark or a trademark of Microsoft Corporation in the United States and/or other countries.

OpenView is a trademark of Hewlett Packard Enterprise Development LP in the U.S. and other countries.

Oracle and Java are registered trademarks of Oracle and/or its affiliates.

Red Hat is a trademark or a registered trademark of Red Hat Inc. in the United States and other countries.

SQL Server is either a registered trademark or a trademark of Microsoft Corporation in the United States and/or other countries.

UNIX is a registered trademark of The Open Group in the United States and other countries.

Windows is either a registered trademark or a trademark of Microsoft Corporation in the United States and/or other countries.

Windows Server is either a registered trademark or a trademark of Microsoft Corporation in the United States and/or other countries.

Other company and product names mentioned in this document may be the trademarks of their respective owners.

■ Microsoft product name abbreviations

This manual uses the following abbreviations for Microsoft product names.

Abbreviation		Full name or meaning
Internet Explorer		Microsoft(R) Internet Explorer(R)
		Windows(R) Internet Explorer(R)
Microsoft SQL Server		Microsoft(R) SQL Server
WSFC		Microsoft(R) Windows Server(R) Failover Cluster
Windows Server 2008	Windows Server 2008 R2	Microsoft(R) Windows Server(R) 2008 R2 Datacenter
		Microsoft(R) Windows Server(R) 2008 R2 Enterprise
		Microsoft(R) Windows Server(R) 2008 R2 Standard
Windows Server 2012	Windows Server 2012	Microsoft(R) Windows Server(R) 2012 Datacenter
		Microsoft(R) Windows Server(R) 2012 Standard
	Windows Server 2012 R2	Microsoft(R) Windows Server(R) 2012 R2 Datacenter

Abbreviation		Full name or meaning
Windows Server 2012	Windows Server 2012 R2	Microsoft(R) Windows Server(R) 2012 R2 Standard
Windows Server 2016		Microsoft(R) Windows Server(R) 2016 Datacenter
		Microsoft(R) Windows Server(R) 2016 Standard
Win32		Win32(R)

Windows is sometimes used generically, referring to Windows Server 2008, Windows Server 2012, and Windows Server 2016.

■ Restrictions

Information in this document is subject to change without notice and does not represent a commitment on the part of Hitachi. The software described in this manual is furnished according to a license agreement with Hitachi. The license agreement contains all of the terms and conditions governing your use of the software and documentation, including all warranty rights, limitations of liability, and disclaimers of warranty.

Material contained in this document may describe Hitachi products not available or features not available in your country.

No part of this material may be reproduced in any form or by any means without permission in writing from the publisher.

■ Issued

Nov. 2018: 3021-3-A55-20(E)

■ Copyright

Copyright (C) 2018, Hitachi, Ltd.

Copyright (C) 2018, Hitachi Solutions, Ltd.

Summary of amendments

The following table lists changes in this manual (3021-3-A55-20(E)) and product changes related to this manual.

Changes	Location
<p>For the following record, the required permissions for each object which PFM - Agent for Microsoft SQL Server uses when collecting records were added:</p> <ul style="list-style-type: none"> • Database Detail • Database Interval 	<i>Table 2-9, Table 2-10</i>
<p>Notes indicating that when a non-default Microsoft SQL Server port number or the named pipe protocol is used to connect with Microsoft SQL Server, a 64-bit <i>alias</i> is required were added.</p>	<i>3.3.2(5), 7.2.1</i>
<p>The version of the data model has been changed from 7.0 to 8.0, and the version of the alarm table has been changed from 11.10 to 11.50.</p>	<i>Chapter 4, Appendix H</i>
<p>With the change of data model, the versions of the following reports that use fields for which the type of their data model was changed in version 8.0 or that refer to such reports were changed:</p> <ul style="list-style-type: none"> • Blocked Sessions • Blocking Locks • Cache Usage • Cache Usage Trend(Multi-Agent) • CPU Usage - Top 10 Sessions • Database Detail • Database Summary • Lock Detail • Lock Overview • Lock Usage - Top 10 Sessions • Log I/O Activity • Log I/O Activity 2 • Memory Usage - Top 10 Sessions • Pending I/O • Physical I/O - Top 10 Sessions • Physical Write Activity • Physical Write Activity 2 • Session Detail • Sessions • System Overview 	<i>Chapter 4</i>
<p>The sizes of the following records were changed:</p> <ul style="list-style-type: none"> • Database Detail (PD_DD) • Database Interval (PI_DI) • Server Overview (PI_SERV) • Server Overview 2 (PI_SRV2) 	<i>Chapter 5</i>
<p>Fields were added to the following records:</p> <ul style="list-style-type: none"> • Database Detail (PD_DD) • Database Interval (PI_DI) • Server Overview (PI_SERV) • Server Overview 2 (PI_SRV2) 	<i>Chapter 5</i>

Changes	Location
The following messages have been changed: <ul style="list-style-type: none"> • KAVF21810-E 	<i>6.4</i>
The folder name of Redistributable Files of PFM - Agent for Microsoft SQL Server was changed.	<i>Appendix F.1</i>
Notes on migration were added.	<i>Appendix G</i>

In addition to the above changes, minor editorial corrections were made.

Preface

This manual describes the functionality and records of JP1/Performance Management - Agent Option for Microsoft(R) SQL Server.

■ Intended readers

This manual is intended for the following readers:

- Users who wish to design or construct an operation monitoring system.
- Users who wish to define conditions for collecting performance data.
- Users who wish to define reports and alarms.
- Users who wish to use collected performance data to monitor a system.
- Users who wish to consider or take actions for a system based on monitoring results.

Readers are assumed to be familiar with Microsoft(R) SQL Server and the operation of the system being monitored, and to have a knowledge of the OS.

For details about how to design and run systems that use JP1/Performance Management, also see the following manuals:

- *JP1/Performance Management Planning and Configuration Guide*
- *JP1/Performance Management User's Guide*
- *JP1/Performance Management Reference*

■ Organization of this manual

This manual consists of the following parts, and is a common reference for the following supported OSs: Windows Server 2008 R2, Windows Server 2012, Windows Server 2012 R2, and Windows Server 2016. Any platform-dependent differences are noted separately in the manual.

Part 1. *Overview*

This part provides an overview of JP1/Performance Management - Agent Option for Microsoft(R) SQL Server.

Part 2. *Configuration and Operations*

Part 2 describes how to install and set up JP1/Performance Management - Agent Option for Microsoft(R) SQL Server, and how to run the program in a cluster system.

Part 3. *Reference*

This part describes the monitoring template, records, and messages of JP1/Performance Management - Agent Option for Microsoft(R) SQL Server.

Part 4. *Troubleshooting*

This part describes the actions to be taken for errors that might occur during operation of JP1/Performance Management - Agent Option for Microsoft(R) SQL Server.

■ Conventions: Diagrams

This manual uses the following conventions in diagrams:

● Computer



● Data flow



● Processing flow



● Program

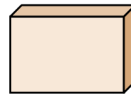

● File

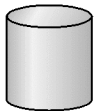

● Network

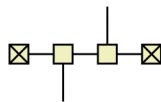

● Server



● Failure



● I/O operation



■ Conventions: Fonts and symbols

Font and symbol conventions are classified as:

- General font conventions
- Conventions in syntax explanations

These conventions are described below.

General font conventions

The following table lists the general font conventions:

Font	Convention
Bold	<p>Bold type indicates text on a window, other than the window title. Such text includes menus, menu options, buttons, radio box options, or explanatory labels. For example, bold is used in sentences such as the following:</p> <ul style="list-style-type: none"> • From the File menu, choose Open. • Click the Cancel button. • In the Enter name entry box, type your name.
<i>Italics</i>	<p>Italics are used to indicate a placeholder for some actual text provided by the user or system. Italics are also used for emphasis. For example:</p> <ul style="list-style-type: none"> • Write the command as follows: <code>copy source-file target-file</code> • Do <i>not</i> delete the configuration file.
Code font	<p>A code font indicates text that the user enters without change, or text (such as messages) output by the system. For example:</p>

Font	Convention
Code font	<ul style="list-style-type: none"> • At the prompt, enter <code>dir</code>. • Use the <code>send</code> command to send mail. • The following message is displayed: <code>The password is incorrect.</code>

Examples of coding and messages appear as follows (although there may be some exceptions, such as when coding is included in a diagram):

```
MakeDatabase
...
StoreDatabase temp DB32
```

In examples of coding, an ellipsis (...) indicates that one or more lines of coding are not shown for purposes of brevity.

Conventions in syntax explanations

Syntax definitions appear as follows:

StoreDatabase [A|B] {C|D|E} (*database-name* ...)

The following table lists the conventions used in syntax explanations.

Example font or symbol	Convention
<code>StoreDatabase</code>	The user should enter code-font characters exactly as shown.
<i>database-name</i>	In actual commands the user must replace the italics by suitable characters.
SD	Bold code-font characters indicate an abbreviation for a command.
<u>A</u>	The underlined characters are the system default when you omit all the items enclosed in brackets. Example: [<u>A</u> B] indicates that the system uses A if you do not specify either A or B.
	Only one of the options separated by a vertical bar can be used at one time. Example: A B C indicates A, or B, or C.
{ }	One of the items enclosed in braces and separated by a vertical bar must be specified. Example: {C D E} indicates that one of the items from C, or D, or E must be specified.
[]	The item or items enclosed in brackets are optional. Example: [A] indicates the specification of A or nothing. [B C] indicates the specification of B or C, or nothing.
...	The item or items preceding the ellipsis (...) can be repeated. To specify multiple items, use a one-byte space to delimit them. Example: A B ... indicates that B can be specified as many times as necessary after A.
()	The items enclosed by the parentheses are in the range to which or ... are applied.

■ Conventions: Mathematical expressions

The following table lists conventions used in mathematical expressions:

Symbol	Description
×	Multiplication sign
/	Division

■ Conventions: Version numbers

The version numbers of Hitachi program products are usually written as two sets of two digits each, separated by a hyphen. For example:

- Version 1.00 (or 1.0) is written as 01-00.
- Version 2.05 is written as 02-05.
- Version 2.50 (or 2.5) is written as 02-50.
- Version 12.25 is written as 12-25.

The version number might be shown on the spine of a manual as *Ver. 2.00*, but the same version number would be written in the program as *02-00*.

Contents

Notices	2
Summary of amendments	5
Preface	7

Part 1: Overview

1	Overview of PFM - Agent for Microsoft SQL Server	17
1.1	Features of PFM - Agent for Microsoft SQL Server	18
1.1.1	Collecting Microsoft SQL Server performance data	18
1.1.2	Collecting performance data based on its characteristics	19
1.1.3	Saving performance data	19
1.1.4	Notifying users of problems in Microsoft SQL Server operation	19
1.1.5	Easy definition of alarms and reports	20
1.1.6	Operation with a cluster system	20
1.2	Overview of collection and management of performance data	22
1.3	Example of performance monitoring using PFM - Agent for Microsoft SQL Server	23
1.3.1	Determining a baseline	23
1.3.2	Insufficient data cache	24
1.3.3	CPU usage ratio per session	24
1.3.4	Insufficient log space	24
1.3.5	Insufficient database space	25
1.3.6	Increase in the number of locks	25
1.3.7	Network load	26
1.3.8	Instance validity	26

Part 2: Configuration and Operations

2	Installation and Setup	27
2.1	Installation and setup	28
2.1.1	Installation and setup workflow	28
2.1.2	Preparation for installing and setting up PFM - Agent for Microsoft SQL Server	29
2.1.3	Installation procedure	36
2.1.4	Setting up PFM - Agent for Microsoft SQL Server	37
2.2	Setup cancellation and uninstallation	58
2.2.1	Cautionary notes on setup cancellation and uninstallation	58
2.2.2	Procedure for canceling setup	59
2.2.3	Procedure for uninstallation	60

2.3	Changing the system configuration of PFM - Agent for Microsoft SQL Server	61
2.4	Changing the operation of PFM - Agent for Microsoft SQL Server	62
2.4.1	Changing the storage location of performance data	62
2.4.2	Updating an instance environment	65
2.4.3	Updating the Store version to 2.0	67
2.5	Starting the command prompt	70
2.5.1	Starting the administrator console provided by the OS	70
2.5.2	Starting the administrator console provided by PFM - Base	70
2.6	Failover in the mirroring configuration	71
2.6.1	Monitoring databases in the mirroring configuration	71
2.6.2	Monitoring while a failover occurs in databases in the mirroring configuration	72
2.6.3	Monitoring after a failover occurs in databases in the mirroring configuration	73
2.7	Monitoring in the SQL Server AlwaysOn Availability Group configuration	74
2.7.1	Monitoring during failover in the SQL Server AlwaysOn Availability Group configuration	74
2.7.2	Monitoring after failover in the SQL Server AlwaysOn Availability Group configuration	75
2.8	Backup and restoration	76
2.8.1	Backup	76
2.8.2	Restoration	77
2.9	Online manuals	78
2.9.1	Setting procedures	78
2.9.2	Viewing the manual	79
3	Operating PFM - Agent for Microsoft SQL Server in a Cluster System	80
3.1	Cluster system overview	81
3.1.1	HA cluster system	81
3.1.2	Federated database server	83
3.2	Processing during failover	85
3.2.1	Failover when a failure occurs on a PFM - Agent host	85
3.2.2	Effects when PFM - Manager stops	87
3.3	Installation and setup	88
3.3.1	Flow for installation and setup	88
3.3.2	Preparation for installation and setup	90
3.3.3	Installation procedure	94
3.3.4	Setup procedure	94
3.4	Setup cancellation and uninstallation	101
3.4.1	Setup cancellation and uninstallation workflow of PFM - Agent for Microsoft SQL Server	101
3.4.2	Setup cancellation procedure	102
3.4.3	Uninstallation procedure	106
3.5	Changing the system configuration of PFM - Agent for Microsoft SQL Server	107
3.6	Changing the operation of PFM - Agent for Microsoft SQL Server	108
3.6.1	Updating an instance environment	108
3.6.2	Exporting and importing the logical-host environment definition file	109

3.7	Notes on operating PFM - Agent for Microsoft SQL Server in a cluster system	110
3.7.1	Host name in the collected performance data	110
3.7.2	Log output for a cluster system	110
3.7.3	About service dependencies	110
3.7.4	Timeout	111

Part 3: Reference

4	Monitoring Template	112
	Overview of the monitoring template	113
	Format of alarm explanations	114
	Notes of alarms	115
	List of alarms	116
	Blocked Sessions	117
	Cache Usage	118
	CPU Usage	119
	Database Space	120
	Log Space Usage	121
	Network Error	122
	Server Status	123
	Format of report explanations	124
	Organization of report folders	125
	List of reports	127
	Blocked Sessions (8.0)	129
	Blocking Locks (8.0)	131
	Cache Usage (8.0)	132
	Cache Usage Trend(Multi-Agent) (8.0)	133
	Cache Usage Trend(Multi-Agent) (8.0)	134
	CPU Usage - Top 10 Sessions (8.0)	135
	Database Detail (8.0)	136
	Database Space Usage (7.0)	138
	Database Space Usage Detail (7.0)	139
	Database Summary (8.0)	140
	Errorlog Detail	142
	Errorlog Overview	143
	Lock Detail (8.0)	144
	Lock Overview (8.0)	145
	Lock Overview by Lock Type	146
	Lock Usage - Top 10 Sessions (8.0)	147
	Log I/O Activity (8.0)	148
	Log I/O Activity 2 (8.0)	149
	Log Space Usage - Top 10 Databases	150
	Memory Usage - Top 10 Sessions (8.0)	151
	Network Activity	152
	Network Activity Trend	153
	Network Activity Trend	154

Pending I/O (8.0)	155
Physical I/O - Top 10 Sessions (8.0)	156
Physical Write Activity (8.0)	157
Physical Write Activity 2 (8.0)	158
Server Configuration Status	159
Server CPU Trend	160
Server CPU Trend	161
Server Space Trend(Multi-Agent)	162
Server Space Trend(Multi-Agent)	163
Server Space Usage (7.0)	164
Session Detail (8.0)	165
Sessions (8.0)	167
System Overview (8.0)	168

5 **Records 170**

Data model	171
Format of record explanations	172
List of ODBC key fields	175
Summary rules	176
List of data types	178
Field values	179
Fields added only when data is stored in the Store database	181
Fields output when data stored in the Store database is exported	182
Notes on records	183
List of records for PFM - Agent for Microsoft SQL Server	185
Config Detail (PD_CD)	187
Database Detail (PD_DD)	189
Database Interval (PI_DI)	193
Database Replication Detail (PD_RD)	195
Database Space Detail (PD_DS)	197
Errorlog Error Detail (PD_EE)	200
Errorlog Summary Detail (PD_ES)	202
Global Server Summary (PI)	204
Global Server Summary 2 (PI_PI2)	207
Instance Availability (PD_IA)	210
Job History Detail (PD_JH)	212
Licensing Detail (PD_LIC)	214
Lock Detail (PD_LD)	215
Procedure Cache Detail (PD_PCAC)	218
Process Detail (PD_PDET)	220
Replication Published Database Overview (PI_RPDB)	223
Replication Summary Detail (PD_RS)	225
Server Detail (PD)	227
Server Locks Detail (PD_LOCK)	233
Server Overview (PI_SERV)	236
Server Overview 2 (PI_SRV2)	240
Server Space Detail (PD_SS)	244

Server Space Interval (PI_SI)	246
SQL Text (PD_SQL)	248
Transaction Log Overview (PI_TLOG)	250
User-Defined Counter Overview (PI_UCTR)	252
User Process Detail (PD_USER)	254

6 Messages 257

6.1	Message format	258
6.1.1	Format of output messages	258
6.1.2	Format of message explanation	259
6.2	Message output destinations	260
6.3	Messages output to the Windows event log	264
6.4	Messages	265

Part 4: Troubleshooting

7 Error Handling Procedures 287

7.1	When an error occurs	288
7.2	Troubleshooting procedures	289
7.2.1	Problems relating to the collection and management of performance data	289
7.2.2	Other problems	290
7.3	Log information	291
7.3.1	Types of log information	291
7.3.2	List of log files and directories	293
7.4	Required troubleshooting information	296
7.4.1	In Windows	296
7.5	Collecting troubleshooting information	300
7.5.1	In Windows	300
7.6	Detecting errors in Performance Management	303
7.7	Recovering from errors in Performance Management system	304

Appendixes 305

A	Estimating System Requirements	306
A.1	Memory requirements	306
A.2	Disk space requirements	306
A.3	Disk space requirements for operation in a cluster system	306
A.4	Calculating the number of instances for records	306
B	List of Identifiers	310
C	List of Processes	311
D	List of Port Numbers	312
D.1	Port numbers for PFM - Agent for Microsoft SQL Server	312
D.2	Routing through a firewall	312
E	PFM - Agent for Microsoft SQL Server Properties	313

E.1	List of Agent Store service properties	313
E.2	List of Agent Collector service properties	316
F	List of Files and Folders	324
F.1	PFM - Agent for Microsoft SQL Server files and directories	324
G	Migration Procedure and Notes on Migration	327
H	Version Compatibility	329
I	Deleting the A4QHITACHIPROCSPDATABASES Stored Procedure	330
I.1	Procedure for deleting A4QHITACHIPROCSPDATABASES	330
J	Outputting Action Log Information	332
J.1	Event types output to the action log	332
J.2	Format for saving the action log files	332
J.3	Action log output format	333
J.4	Settings for outputting action logs	337
K	Linking with JP1/SLM	340
L	About Communication in IPv4 Environments and IPv6 Environments	341
M	Version Revisions	342
M.1	Revisions in 11-50	342
M.2	Revisions in 11-10	343
M.3	Revisions in 11-00	345
M.4	Revisions in 10-00	346
M.5	Revisions in 09-00	346
N	Reference Material for This Manual	347
N.1	Related publications	347
N.2	Conventions: Abbreviations for product names	347
N.3	Conventions: Acronyms	349
N.4	Conventions: Product names, service IDs, and service keys	350
N.5	Conventions: Installation folder	350
N.6	Conventions: KB, MB, GB, and TB	351
O	Glossary	352

Index 359

1

Overview of PFM - Agent for Microsoft SQL Server

This chapter provides an overview of PFM - Agent for Microsoft SQL Server.

1.1 Features of PFM - Agent for Microsoft SQL Server

PFM - Agent for Microsoft SQL Server is a program that monitors the performance of a Microsoft SQL Server and collects and manages its performance data.

PFM - Agent for Microsoft SQL Server has the following features.

- Ability to analyze the operating status of Microsoft SQL Server
PFM - Agent for Microsoft SQL Server provides the information needed for easy analysis of the operating status of Microsoft SQL Server. It does so by collecting and summarizing performance data (such as session statistics) obtained from the Microsoft SQL Server instance being monitored, and then graphically displaying any trends or changes.
- Ability to detect Microsoft SQL Server problems and quickly provide the information needed to identify the cause of a problem
In the event of a problem, such as a malfunction in a session on the Microsoft SQL Server system being monitored, PFM - Agent for Microsoft SQL Server alerts the user to the problem at an early stage by using email or other means to notify the user. PFM - Agent for Microsoft SQL Server also provides a graphical display of the information needed to identify the cause of a problem.

To use PFM - Agent for Microsoft SQL Server, you must also install the programs PFM - Manager, and PFM - Web Console.

The following subsections summarize the functions of PFM - Agent for Microsoft SQL Server.

1.1.1 Collecting Microsoft SQL Server performance data

PFM - Agent for Microsoft SQL Server enables you to collect performance data (statistical data such as the usage ratio of the database space and the cache hit rate) on the current Microsoft SQL Server session on the host being monitored.

Note

Performance data containing characters other than Shift-JIS (for Japanese Windows) or GB18030 (for Simplified-Chinese Windows) or 7-bit ASCII (for other Windows) cannot be collected in PFM - Agent for Microsoft SQL Server.

With PFM - Agent for Microsoft SQL Server, you can use the collected performance data as follows:

- To graphically display the operating status of Microsoft SQL Server
By using PFM - Web Console, you can process and display performance data in a graphical format called a *report*. A report facilitates the analysis of the Microsoft SQL Server operating status.
There are two types of reports:
 - *Real-time reports*
A real-time report indicates the current status of a Microsoft SQL Server system being monitored. It is used primarily to check the current status of the system and to detect problems in the system. To display real-time reports, PFM - Agent for Microsoft SQL Server uses current performance data that has just been collected.
 - *Historical reports*
A historical report indicates the status of a Microsoft SQL Server system being monitored from a selected point of time in the past to the present. It is used primarily to analyze trends in the system. To display a historical report, the system uses performance data that has been stored in a database for PFM - Agent for Microsoft SQL Server.

- As criteria for determining whether a problem has occurred
You can set PFM - Agent for Microsoft SQL Server to take some action (such as notifying the user) if collected performance data indicates an abnormal condition.

1.1.2 Collecting performance data based on its characteristics

PFM - Agent for Microsoft SQL Server collects performance data in *records*. Each record consists of smaller units called *fields*. Collectively, the records and fields are referred to as the *data model*.

Records are classified into two types according to their characteristics. These record types are predefined in PFM - Agent for Microsoft SQL Server. The user simply uses PFM - Web Console to specify the performance data records to be collected.

PFM - Agent for Microsoft SQL Server supports the following two record types:

- *Product Interval record type* (referred to hereafter as the *PI record type*)
For records of the PI record type, the system collects performance data for a specified interval, such as the number of processes executed in one minute. You can use these records to analyze the changes or trends in the system status over time.
- *Product Detail record type* (referred to hereafter as the *PD record type*)
For records of the PD record type, the system collects performance data that indicates the system status at a specific point in time, such as detailed information about the currently active processes. You can use these records to obtain the system status at a particular time.

For more information about record types, see [5. Records](#).

1.1.3 Saving performance data

Because collected performance data is stored in a special database, you can save performance data up to the current date, and use it to analyze trends (from a selected point in the past to the current date) in the Microsoft SQL Server operating states. This special database is called the *Store database* of PFM - Agent for Microsoft SQL Server. Trends are analyzed using historical reports.

Use PFM - Web Console to select the performance data records to be stored in the Store database. For details about how to select records with PFM - Web Console, see the chapter on the management of operation monitoring data in the *JPI/Performance Management User's Guide*.

1.1.4 Notifying users of problems in Microsoft SQL Server operation

In addition to using performance data collected by PFM - Agent for Microsoft SQL Server to display Microsoft SQL Server performance as reports, you can also use it to warn the user of a problem or error occurring during Microsoft SQL Server operation.

Suppose that you wish to notify the user by email whenever the percentage of cache hit rate is less than 85%. You can do this by setting *percentage of cache hit rate is less than 85%* as the abnormal condition threshold, and setting the system to send an email to the user when this threshold is reached. What the system does when the threshold is reached is called an *action*. The following types of actions are available:

- Sending an email
- Executing a command
- Issuing an SNMP trap
- Issuing a JPI event

The definition of a threshold or action is called an *alarm*. A table of defined alarms is called an *alarm table*. Once an alarm table is defined, it is associated with PFM - Agent for Microsoft SQL Server. Associating an alarm table with PFM - Agent for Microsoft SQL Server is called *binding*. Once an alarm table has been bound to PFM - Agent for Microsoft SQL Server, whenever the performance data collected by PFM - Agent for Microsoft SQL Server reaches the threshold defined as an alarm, the event is reported to the user.

By defining alarms and actions, you can detect Microsoft SQL Server problems at an early stage and take appropriate action.

For details about how to set alarms and actions, see the chapter on alarm-based operation monitoring in the *JPI/Performance Management User's Guide*.

1.1.5 Easy definition of alarms and reports

PFM - Agent for Microsoft SQL Server provides a *monitoring template* that contains predefined information necessary for standard reports and alarms. The *monitoring template* facilitates setup for monitoring the Microsoft SQL Server operating status, because it does not require you to make any complicated definitions. You can also customize the monitoring template as needed for your environment. For details about how to use the *monitoring template*, see the chapter on creating reports for operation analysis or the chapter on alarm-based operation monitoring in the *JPI/Performance Management User's Guide*. For details about the *monitoring template*, see Part 3, [4. Monitoring Template](#).

1.1.6 Operation with a cluster system

By using a cluster configuration, you can create a highly reliable system that continues to operate even in the event of a system failure. As a result, the programs in Performance Management can continue operation and monitoring 24 hours a day.

The following figure shows an example of operation when a problem occurs on the monitored host in a cluster system.

Figure 1–1: Example of an PFM - Agent for Microsoft SQL Server configuration in an HA cluster system

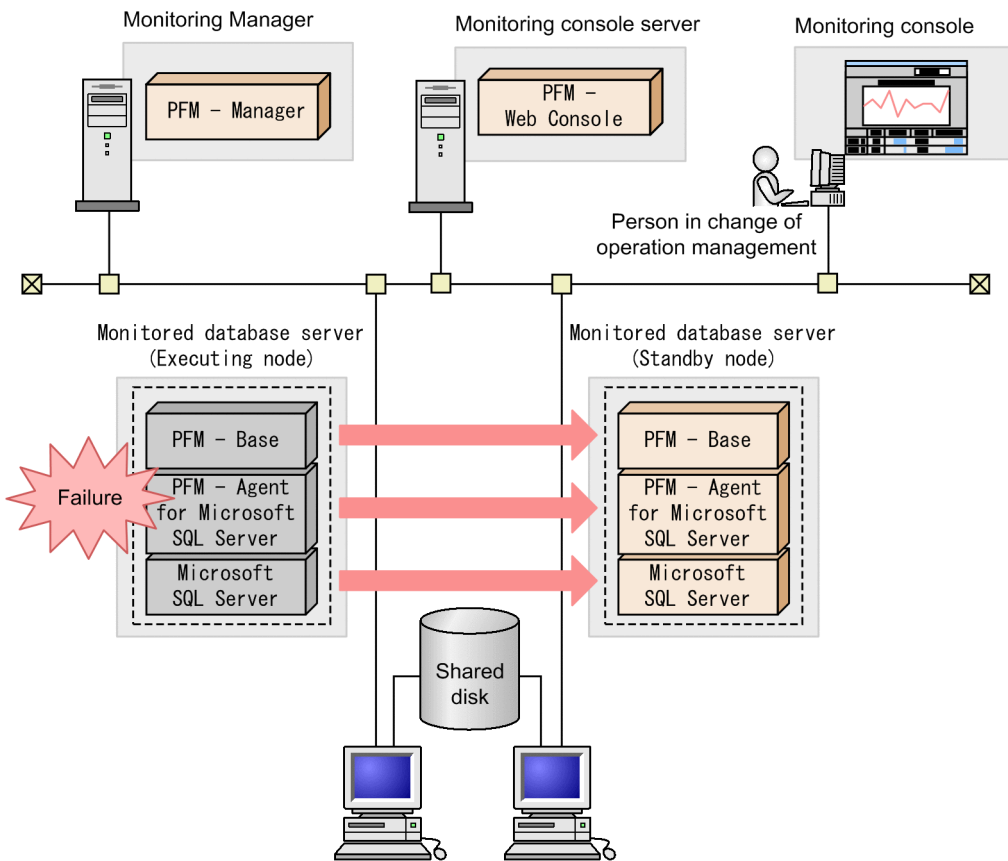

Legend
 : Failover

Set up two environments with the same configuration, and define the environment for normal operation as an *executing node* and the other for failure operation as a *standby node*.

For more details about running the programs in Performance Management on a cluster system, see Part 2, 3. *Operating PFM - Agent for Microsoft SQL Server in a Cluster System*.

1.2 Overview of collection and management of performance data

The procedures for collecting and managing performance data depend on the record type used to store the performance data. The records for PFM - Agent for Microsoft SQL Server are classified into the following two types:

- PI record type
- PD record type

For details about how to collect and manage performance data, see the following sections:

- Performance data collection procedure

For details about the performance data collection procedure, see the chapter on Performance Management functionality in the *JPI/Performance Management Planning and Configuration Guide*.

For details about the values of the collected performance data, see [5. Records](#).

- Performance data management procedure

For details about the performance data management procedure, see the chapter on Performance Management functionality in the *JPI/Performance Management Planning and Configuration Guide*.

When you want to select performance data from the records collected and managed by PFM - Agent, you use PFM - Web Console. For details about how to select performance data, see the chapter on the management of operation monitoring data in the *JPI/Performance Management User's Guide*.

1.3 Example of performance monitoring using PFM - Agent for Microsoft SQL Server

Performance monitoring is critical for the setup and management of Microsoft SQL Server environments.

Performance monitoring using PFM - Agent for Microsoft SQL Server can be used to perform the following:

- Analysis of performance data to discover causes of bottlenecks
- Monitoring to check whether the Microsoft SQL Server is running properly

During Microsoft SQL Server operation, specific causes can negatively impact overall Microsoft SQL Server performance. These causes can include the following:

- Insufficient data cache
- CPU usage ratio per session
- Insufficient log space
- Insufficient database space
- Increase in the number of locks

It is very important to make sure that the Microsoft SQL Server is running properly. In addition to performance standpoints, monitoring such as the following can be used to check whether a Microsoft SQL Server is running properly.

- Network load monitoring
- Instance validity

Performance monitoring using PFM - Agent for Microsoft SQL Server can be performed to achieve stable operation for Microsoft SQL Server servers.

Note that the performance monitoring method thresholds are for reference only. The actual thresholds need to be determined through baseline measurement. The actual items set need to be determined based on the type of operation for the Microsoft SQL Server.

1.3.1 Determining a baseline

Determining a baseline involves using the results of performance measurement to calculate the line at which no system operation problems are anticipated.

Performance Management products treat baseline values as *thresholds* for system operation monitoring. As such, determining a baseline is important for deciding on a threshold and performing performance monitoring.

Hitachi recommends that you perform the following when you determine a baseline:

- Measuring statuses during peak times, such as by performing testing under heavy operation environment load
- Re-measure baselines when system resources or operation environments are changed, as these can differ significantly by system configuration

1.3.2 Insufficient data cache

The insufficient data cache affects the performance of the Microsoft SQL Server. To monitor the insufficient data cache, use the Cache Usage alarm in the monitoring template which PFM - Agent for Microsoft SQL Server provides. The Cache Usage alarm enables you to monitor how many times the cache hits occur instead of loading data from the storage disk

The following table explains the Cache Usage alarm in the monitoring template:

Alarm name	Record used	Field used	Abnormal condition	Warning condition	Values measured
Cache Usage	PI_SERV	Cache Hit %	Cache Hit % < 85	Cache Hit % < 95	The data cache can be insufficient.

Diagnosis:

If the value of Cache Hit % field is lower than 85 %, the data cache can be insufficient.

The insufficient data cache lowers the performance of the search and update process.

Prescription:

Either increase the value of the max server memory option or add the physical memory to the system so that the size of the data cache increases.

For details about the Cache Usage alarm, see *Cache Usage* in *4. Monitoring Template*.

1.3.3 CPU usage ratio per session

The CPU usage ratio per session may affect the performance of the Microsoft SQL Server. To monitor the CPU usage ratio per session, use the CPU Usage alarm in the monitoring template which PFM - Agent for Microsoft SQL Server provides. The CPU Usage alarm enables you to monitor the top 10 most CPU-cycle used sessions at present.

The following table explains the CPU Usage alarm in the monitoring template:

Alarm name	Record used	Field used	Abnormal condition	Warning condition	Values measured
CPU Usage	PI	CPU %	CPU % > 90	CPU % > 80	Microsoft SQL Server can be too busy.

Diagnosis:

If the value of CPU % field exceeds 90 %, the system can be too busy.

Prescription:

Remove what makes the system too busy to lessen the system load.

For details about the CPU Usage alarm, see *CPU Usage* in *4. Monitoring Template*.

1.3.4 Insufficient log space

The insufficient log space affects the performance of the Microsoft SQL Server. To monitor the insufficient log space, use the Log Space Usage alarm which PFM - Agent for Microsoft SQL Server provides. The Log Space Usage alarm enables you to monitor the top 10 most log-space used database.

The following table explains the Log Space Usage alarm in the monitoring template:

Alarm name	Records used	Field used	Abnormal condition	Warning condition	Values measured
Log Space Usage	PI_TLOG	Log Space Used %	Log Space Used % > 90	Log Space Used % > 80	Log space can be insufficient.

Diagnosis:

If the value of Log Space Used % exceeds 90 %, the log space can be insufficient.

Prescription:

Prescription:

Add a transaction log file or enlarge the size of the transaction log file.

For details about the Log Space Usage alarm, see *Log Space Usage* in *4. Monitoring Template*.

1.3.5 Insufficient database space

The insufficient database space affects the performance of the Microsoft SQL Server. To monitor the insufficient database space, use the Database Space alarm which PFM - Agent for Microsoft SQL Server provides. The Database Space alarm enables you to monitor the available space for each database.

The following table explains the Database Space alarm in the monitoring template:

Alarm name	Record used	Field used	Abnormal condition	Warning condition	Values measured
Database Space	PD_DS	Free %	Free % < 10	Free % < 20	Available space for database can be insufficient.

Diagnosis:

If the value of Database Space is less than 10 %, the available space for databases can be insufficient.

Prescription:

Reconsider how to access the Microsoft SQL Server database

For details about the Database Space alarm, see *Database Space* in *4. Monitoring Template*.

1.3.6 Increase in the number of locks

The increase in the number of locks affects the performance of the Microsoft SQL Server. To monitor the increase in the number of locks, use the Blocked Sessions alarm in the monitoring template which PFM - Agent for Microsoft SQL Server provides. The Blocked Sessions alarm monitors the number of sessions that are waiting for lock release by other sessions.

The following table explains the Blocked Sessions alarm in the monitoring template:

Alarm name	Record used	Field used	Abnormal condition	Warning condition	Values measured
Blocked Sessions	PD	Blocked Processes	Blocked Processes > 2	Blocked Processes > 0	The sessions that set the locks can be running.

Diagnosis:

If the value of the Blocked Sessions alarm exceeds 2, the sessions that set the locks can be running.

Prescription:

Check the active sessions connecting to the Microsoft SQL Server.

For details about the Blocked Sessions alarm, see *Blocked Sessions* in *4. Monitoring Template*.

1.3.7 Network load

Network load affects the performance of the Microsoft SQL Server. To monitor network load, use the Network Error alarm in the monitoring template provided by PFM - Agent for Microsoft SQL Server. The Network Error alarm enables you to monitor how Microsoft SQL Server operation affects the network.

The following table explains the Network Error alarm in the monitoring template:

Alarm name	Record used	Field used	Abnormal condition	Warning condition	Values measured
Network Error	PD	Pkt Errors	Pkt Errors > 2	Pkt Errors > 0	The Microsoft SQL Server might significantly increase network load.

Diagnosis:

If the value of the `Network Error` alarm exceeds 2, the Microsoft SQL Server might significantly increase network load.

Prescription:

Modify network access to the Microsoft SQL Server or the system configuration related to the network.

1.3.8 Instance validity

To monitor whether a Microsoft SQL Server instance is valid, use the Server Status alarm in the monitoring template provided by PFM - Agent for Microsoft SQL Server. The Server Status alarm enables you to monitor the validity of a Microsoft SQL Server instance.

The following table explains the Server Status alarm in the monitoring template:

Alarm name	Record used	Field used	Abnormal condition	Warning condition	Values measured
Server Status	PD_IA	Availability	Availability = 0	Availability = 0	The Microsoft SQL Server instance might be invalid.

Diagnosis:

If the value of `Availability` is 0 (stopped), the Microsoft SQL Server instance might be invalid.

Prescription:

Check whether a connection to the Microsoft SQL Server can be established. If the connection cannot be established, modify the environment that communicates with Microsoft SQL Server. If you cannot identify any problems in the communication environment, check the status of the Microsoft SQL Server service.

For details about the Server Status alarm, see *Server Status* in *4. Monitoring Template*.

2

Installation and Setup

This chapter describes the procedures for installing and setting up PFM - Agent for Microsoft SQL Server. For details about how to install and set up an entire system that operates the programs of the Performance Management products, see the chapter that describes installation and setup for Windows in the *JP1/Performance Management Planning and Configuration Guide*.

2.1 Installation and setup

This section describes the procedures for installing and setting up PFM - Agent for Microsoft SQL Server.

2.1.1 Installation and setup workflow

This section explains the flow for installing and setting up PFM - Agent for Microsoft SQL Server.

Figure 2–1: Installation and setup flow

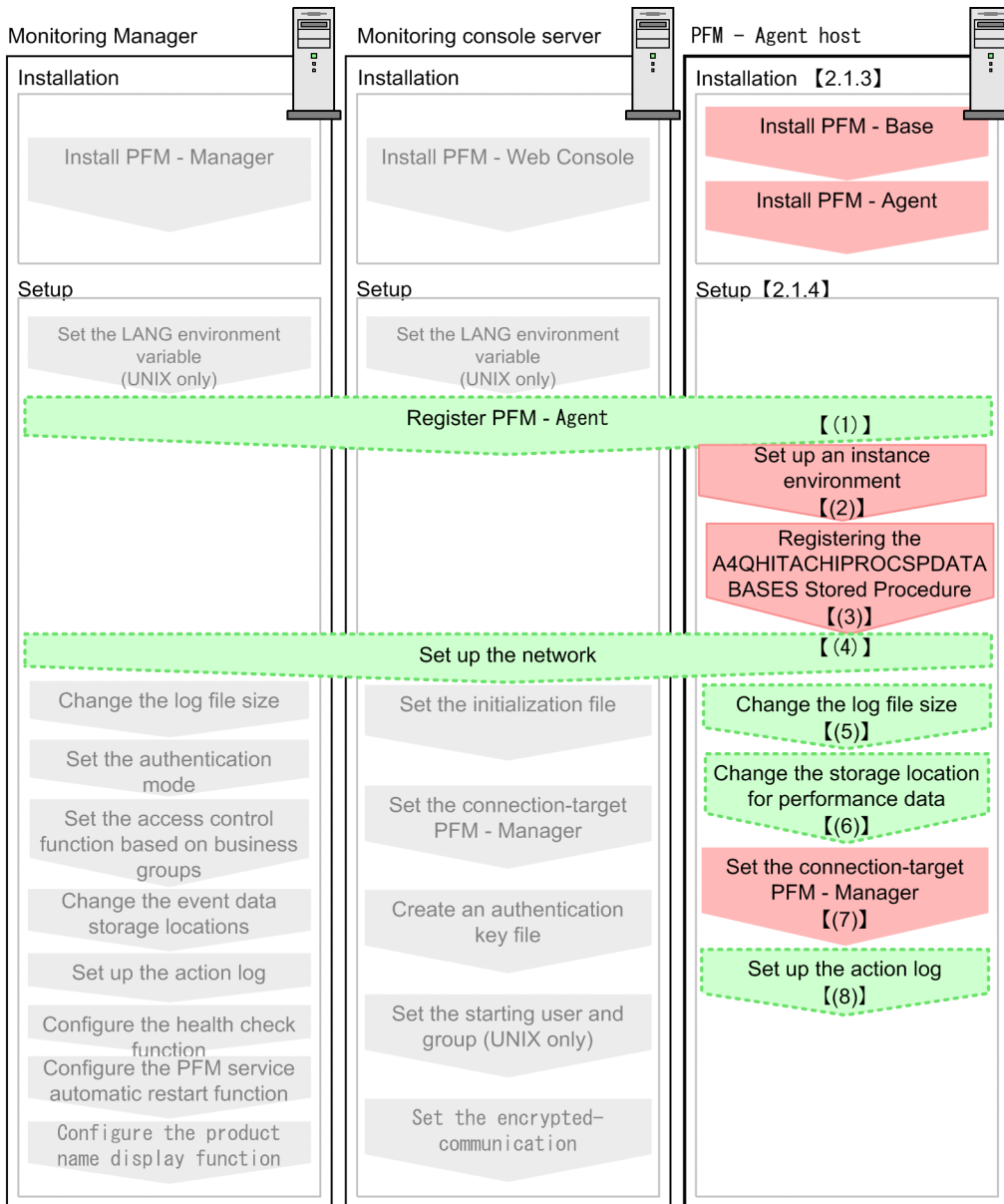

Legend:

- ▾ : Mandatory setup item
- ▾ : Indicates an option step
- ▾ : Described in the manual *JP1/Performance Management Planning and Configuration Guide*
- []** : Text reference

For details about how to install and set up PFM - Manager and PFM - Web Console, see the chapter explaining installation and setup in the *JPI/Performance Management Planning and Configuration Guide*.

Note that setup commands that require information to be entered by the user can be selected to run interactively or non-interactively.

When a command is run interactively, a prompt is issued to the user requesting entry of a required value.

When a command is run non-interactively, the user is not prompted. Instead, the input information required for execution of the command is provided by means of option specifications and definition files. By automating setup tasks through batch processing and remote execution, you can reduce the administrative burden and operational costs.

For details about commands, see the manual *JPI/Performance Management Reference*.

2.1.2 Preparation for installing and setting up PFM - Agent for Microsoft SQL Server

Check the following items before installing and setting up PFM - Agent for Microsoft SQL Server.

(1) OS requirements

PFM - Agent for Microsoft SQL Server can run on the following operating systems (OSs):

- Windows Server 2008 R2
- Windows Server 2012
- Windows Server 2012 R2
- Windows Server 2016

(2) Network environment settings

To operate PFM - Agent for Microsoft SQL Server with Performance Management, you need to set the network environment such as the IP address or port number.

(a) IP address settings

The PFM - Agent for SQL Server host must be set up in a network environment where IP addresses can be resolved from host names. PFM - Agent for SQL Server will not start in an environment where IP addresses cannot be resolved.

PFM - Agent for Microsoft SQL Server can run in an IPv6 environment and dual stack environment in addition to an IPv4 environment.

Actual host names or alias names can be used for a monitoring host name (the name used as the host name of a Performance Management system).

- When using an actual host name as a monitoring host name
Execute the `hostname` command on a Windows system or `uname -n` command on a UNIX system to check the host name, and set up the environment so that it can resolve IP addresses. Note that on a UNIX system, the host name obtained by the `hostname` command can also be used.
- When using an alias name as a monitoring host name
Set up the environment so that it can resolve the IP addresses for the set alias name.

For details about monitoring host name settings, see the chapter explaining installation and setup in the *JPI/Performance Management Planning and Configuration Guide*.

Host names and IP addresses can be set using any of the following:

- The host information settings file for Performance Management (`jpchosts` file)
- `hosts` file
- DNS (Domain Name System)

Important

Notes:

- Although the Performance Management programs and PFM - Agent for Microsoft SQL Server can operate in a DNS environment, they do not support host names in FQDN (Fully Qualified Domain Name) format. When you specify an IP address, use the host name returned by the `hostname` command after removing the domain name portion.
- If you intend to use Performance Management within multiple LAN environments, set the IP addresses in the `jpchosts` file. For details, see the chapter on installation and setup in the *JPI/Performance Management Planning and Configuration Guide*.
- Performance Management programs cannot operate on the hosts to which IP addresses are assigned dynamically by DHCP. Make sure that all the hosts on which Performance Management programs are installed are configured with user-specific static IP addresses.

Performance Management supports IPv6 environments as well as IPv4 environments as a network configuration. Therefore, Performance Management can operate even in a network configuration in which both an IPv4 environment and an IPv6 environment are used.

PFM - Agent for Microsoft SQL Server can communicate with PFM - Manager via IPv6.

Note that this explanation applies only when the OS of a host on which PFM - Agent for Microsoft SQL Server is installed is Windows, and the OS of a host on which PFM - Manager is installed is Windows or Linux.

For details about the scope of communication in an environment with both IPv4 and IPv6, see [L. About Communication in IPv4 Environments and IPv6 Environments](#).

When you want to use IPv6 for communication, the settings for using IPv6 need to be enabled on both the PFM - Manager host and the PFM - Agent host. In addition, before installing PFM - Agent for Microsoft SQL Server, you need to enable the use of IPv6 on the PFM - Agent host. You have to execute the `jpccconf ipv6 enable` command to enable this setting. If this setting is already enabled, however, you do not need to execute the command. If you want to check whether the use of IPv6 is enabled, execute the `jpccconf ipv6 display` command.

For details about the `jpccconf ipv6 enable` command and `jpccconf ipv6 display` command, see the chapter that describes commands in the manual *JPI/Performance Management Reference*. For details about the conditions or occasions for executing the `jpccconf ipv6 enable` command, see the chapter that describes network configuration examples in an environment that includes IPv6 in the *JPI/Performance Management Planning and Configuration Guide*.

When you use IPv6 for communication between a monitored host and PFM - Agent for Microsoft SQL Server, specify the name of a monitored host where name resolution can be performed.

Communication between PFM - Agent for Microsoft SQL Server and a monitoring target is performed with an IP address that can be resolved. Also, if an IPv4 environment and an IPv6 environment are both used, and communication between PFM - Agent for Microsoft SQL Server and the monitoring target fails with an IP address that can be resolved, the communication is not retried by using another IP address.

For example, if communication fails when IPv4 is used, IPv6 is not used to retry communication. Similarly, if communication fails when IPv6 is used, IPv4 is not used to retry communication. Make sure beforehand that a connection can be established.

(b) Port number settings

The following table shows the default port numbers assigned to the services of Performance Management programs. For other services and programs, available port numbers are automatically assigned each time the services and programs are started. If you use Performance Management in a firewall environment, use fixed port numbers. For details about how to set fixed port numbers, see the chapter on installation and setup in the *JPI/Performance Management Planning and Configuration Guide*.

Table 2–1: Default port number of each service

Service description	Service name	Parameter	Port number	Remarks
Service configuration information management function	Name Server	jp1pcnsvr	22285	The port number used by the Name Server service of PFM - Manager. This port is set up on every Performance Management host.
Service status management function	Status Server	jp1pcstatsvr	22350	The port number used by the Status Server service of PFM - Manager and PFM - Base. This port is set up on the hosts on which PFM - Manager and PFM - Base are installed.
JPI/SLM linkage facility	JPI/ITSLM	--	20905	The port number set by JPI/SLM.

Legend:

--: None

Ensure that the network is set up to allow communication using these port numbers, since they are used by PFM - Agent for Microsoft SQL Server.

(3) OS user permission for installing PFM - Agent for Microsoft SQL Server

When installing PFM - Agent for Microsoft SQL Server, always use an account that belongs to the Administrators group.

(4) Prerequisite programs

This subsection describes the prerequisite programs for installing PFM - Agent for Microsoft SQL Server.

Figure 2–2: Program configuration

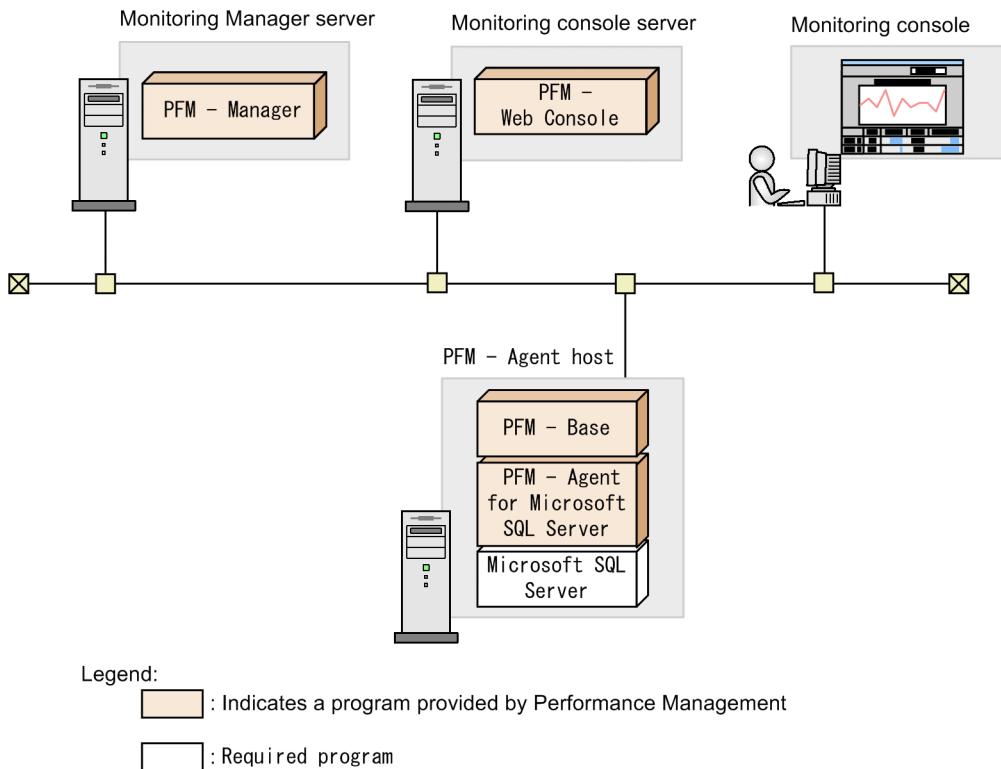

(a) Programs that can be monitored

PFM - Agent for Microsoft SQL Server can monitor the following programs:

When you use Windows Server 2008

- Microsoft SQL Server 2005 Enterprise Edition (Service Pack 3 or later)
- Microsoft SQL Server 2005 Standard Edition (Service Pack 3 or later)
- Microsoft SQL Server 2008 Enterprise Edition
- Microsoft SQL Server 2008 Standard Edition
- Microsoft SQL Server 2008 R2 Enterprise
- Microsoft SQL Server 2008 R2 Standard
- Microsoft SQL Server 2012 Enterprise
- Microsoft SQL Server 2012 Business Intelligence
- Microsoft SQL Server 2012 Standard
- Microsoft SQL Server 2014 Enterprise
- Microsoft SQL Server 2014 Business Intelligence
- Microsoft SQL Server 2014 Standard

When you use Windows Server 2012

- Microsoft SQL Server 2012 Enterprise
- Microsoft SQL Server 2012 Business Intelligence
- Microsoft SQL Server 2012 Standard
- Microsoft SQL Server 2014 Enterprise

- Microsoft SQL Server 2014 Business Intelligence
- Microsoft SQL Server 2014 Standard
- Microsoft SQL Server 2016 Enterprise
- Microsoft SQL Server 2016 Standard
- Microsoft SQL Server 2017 Enterprise
- Microsoft SQL Server 2017 Standard

When you use Windows Server 2016

- Microsoft SQL Server 2016 Enterprise
- Microsoft SQL Server 2016 Standard
- Microsoft SQL Server 2017 Enterprise
- Microsoft SQL Server 2017 Standard

To monitor this program, it must be installed on the same host as PFM - Agent for Microsoft SQL Server.

(b) Performance Management programs

Install PFM - Agent for Microsoft SQL Server and PFM - Base on the PFM - Agent host. PFM - Base is a prerequisite program for PFM - Agent for Microsoft SQL Server. Only one instance of PFM - Base is required, even when multiple instances of PFM - Agent for Microsoft SQL Server are installed on one host.

Note that you do not need to install PFM - Base if PFM - Manager and PFM - Agent for Microsoft SQL Server are installed on the same host.

To use PFM - Agent for Microsoft SQL Server to monitor Microsoft SQL Server operation, PFM - Manager and PFM - Web Console are required.

(5) Installation and setup in a cluster system

When you install and set up PFM - Agent in a cluster system, the prerequisite network environment and program configuration is different from those for a normal system. There are also additional tasks that must be performed on the executing nodes and standby nodes. For details, see [3. Operating PFM - Agent for Microsoft SQL Server in a Cluster System](#).

(6) Preparation for collecting data when an error occurs

If a problem occurs, user mode process dumps, and other data might be required. To obtain these dumps when a problem has occurred, set output of these dumps in advance by using one of the following methods.

You can use the following registry setting to obtain user mode process dumps of data you can use to investigate for troubleshooting when an application program has terminated:

```
\\HKEY_LOCAL_MACHINE\SOFTWARE\Microsoft\Windows\Windows Error Reporting
\LocalDumps
```

Specify the following registry key values:

- DumpFolder: REG_EXPAND_SZ *dump-output-folder-name*
(Permission to write to the output destination folder is needed.)
- DumpCount: REG_DWORD *Number-of-dumps-to-be-saved*

- DumpType: REG_DWORD 2

Notes:

- When you set the registry to output user mode process dumps, user mode process dumps are output for not only JPI programs, but also other application programs. Make sure you keep this in mind when you set that user mode process dumps are to be output.
- When user mode process dumps are output, available disk space can be adversely affected. When user mode process dumps are set to be output, make sure that you specify a dump output folder that has enough disk space for the dumps.

(7) Cautionary notes

Note the following when installing and setting up Performance Management.

(a) Note on environmental variable

Because Performance Management uses JPC_HOSTNAME as an environment variable, do not set it as a user-specific environment variable, as this will prevent Performance Management from operating properly.

Notes on installing and setting up multiple Performance Management programs on one host

With Performance Management, you can install PFM - Manager, PFM - Web Console, and PFM - Agent for Microsoft SQL Server on the same host. When doing so, note the following:

- When PFM - Manager and PFM - Agent for Microsoft SQL Server are installed on the same host, PFM - Base is not required. In this case, PFM - Manager is a prerequisite program for PFM - Agent for Microsoft SQL Server and must be installed before PFM - Agent for Microsoft SQL Server is installed.
- You cannot install PFM - Base and PFM - Manager on the same host. If you want to install PFM - Manager on a host on which PFM - Base and PFM - Agent for Microsoft SQL Server are already installed, uninstall all Performance Management programs except PFM - Web Console, and then install PFM - Manager and PFM - Agent for Microsoft SQL Server in this order. The same applies when you install PFM - Base on a host on which PFM - Manager and PFM - Agent for Microsoft SQL Server are already installed: you must uninstall all Performance Management programs except PFM - Web Console, and then install PFM - Base and PFM - Agent for Microsoft SQL Server in that order.
- If PFM - Manager already exists on the host where PFM - Agent for Microsoft SQL Server is to be installed, the PFM - Manager on the local host becomes the connection-target PFM - Manager. In this case, you cannot change the connection target to the PFM - Manager on a remote host. To connect to a PFM - Manager on a remote host, PFM - Manager must not be already installed on your host.
- If you install PFM - Manager on a host on which PFM - Agent for Microsoft SQL Server is already installed, the connection-target PFM - Manager is reset to the local host. Since the setting results are output to the common message log, check the log to verify the setting.
- Before installing PFM - Agent for Microsoft SQL Server on a host on which PFM - Web Console has been installed, you must close all windows of Web browser.
- When you perform a new installation of a Performance Management program, the status management facility will be enabled by default. To change the setting of the status management facility, see the chapter on error detection for Performance Management in the *JPI/Performance Management User's Guide*.

Point:

To improve system performance and reliability, we recommend running PFM - Manager, PFM - Web Console, and PFM - Agent for Microsoft SQL Server on separate hosts.

(b) Notes on upgrading PFM - Agent for Microsoft SQL Server

For details about notes on upgrading the versions of Performance Management programs, see the section describing the notes on version upgrading in the chapter that explains installation and setup in the *JPI/Performance Management Planning and Configuration Guide*.

For details about notes on upgrading the version of PFM - Agent for Microsoft SQL Server, see *G. Migration Procedure and Notes on Migration*.

For details about version upgrading, see the appendix in the *JPI/Performance Management Planning and Configuration Guide*.

(c) Other cautionary notes

- When you perform a new installation of PFM - Agent in an environment in which no other Performance Management program has been installed, make sure that there are no files or folders in the installation folder.
- You might be prompted to restart the system if you attempt to install PFM - Agent while another Performance Management program or service is running. Alternatively, you might be prompted to restart the system while Windows Event Viewer or another program that references Performance Management files is running. In either case, restart the system as indicated in the message, and complete the installation.
- The installer might be unable to expand the files required for installation if you attempt to install PFM - Agent in the following cases: (1) while a Performance Management program or service is running or while another program that references Performance Management files (for example, Windows Event Viewer) is running, (2) when there is insufficient disk space, or (3) when you do not have the required folder permission. Stop any active Performance Management programs or services or other programs that reference Performance Management files, and then perform the installation again. If the problem is caused by insufficient disk space or a lack of the appropriate folder permissions, fix the problem and then perform the installation again.
- When installing the Performance Management program, check whether any of the following security-related programs are installed. If they are installed, perform the measures below:
 - Security monitoring programs
Stop or change the settings for security monitoring programs so that installation of the Performance Management program is not prevented.
 - Virus detection programs
We recommend that any virus detection programs be stopped before the Performance Management program is installed.
If a virus detection program is running during installation of the Performance Management program, the installation speed might suffer, and installation might not be executed, might not be performed correctly.
 - Process monitoring software
Stop or change the settings for any process monitoring programs, so that monitoring is not performed for Performance Management services, and Common Component services.
If a process monitoring program starts or stops these services during installation of the Performance Management program, installation might fail.
- Setting a logical host and the remote host name, and then monitoring the operation of Microsoft SQL Server on a remote host is not guaranteed.

2.1.3 Installation procedure

This subsection explains the order in which the component programs of PFM - Agent for Microsoft SQL Server are to be installed, and describes how to install these programs from the supplied medium.

(1) Order of installation

Install PFM - Base, and then PFM - Agent for Microsoft SQL Server. PFM - Base must be installed on the host before you install PFM - Agent for Microsoft SQL Server.

If you want to install PFM - Agent for Microsoft SQL Server and PFM - Manager on the same host, install PFM - Manager before you install PFM - Agent for Microsoft SQL Server. When the Store database version is updated from 1.0 to 2.0, the setup procedure differs depending on the version of PFM - Manager or PFM - Base that is already installed. For details about how to set up version 2.0 of the Store database, see [2.4.3 Updating the Store version to 2.0](#).

Multiple instances of PFM - Agent on the same host can be installed in any order.

Figure 2–3: Program installation procedure

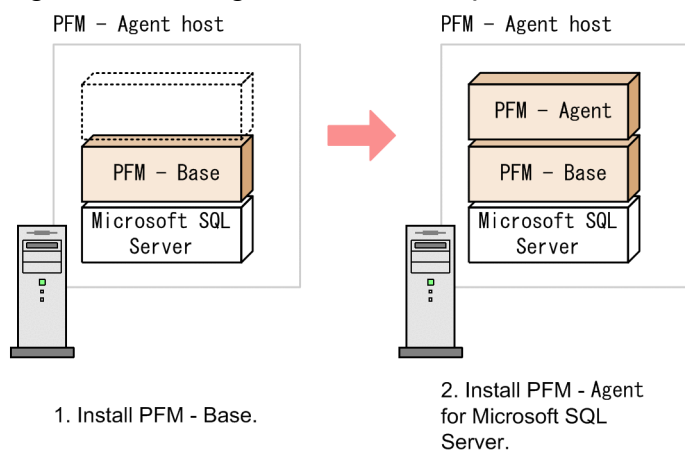

(2) How to install the programs

You can install Performance Management programs on a Windows host either by using the supplied medium, or by using JP1/Software Distribution to perform a remote installation. For details about how to use JP1/Software Distribution, see the *Job Management Partner 1/Software Distribution Administrator's Guide Volume 1*, for Windows systems.

Precaution

If user account control functionality (UAC) is enabled on the OS, the User Account Control dialog box might be displayed during installation. If this dialog box is displayed, click the Continue button to continue installation, or click the Cancel button to cancel installation.

To install PFM - Agent for Microsoft SQL Server:

1. Log on to the host on which you intend to install the programs as an administrator.
2. If any Performance Management services are running on the local host, stop all of them.
The services you are going to stop are the Performance Management services running on both the physical and logical hosts. For details about how to stop services, see the chapter that explains startup and termination of Performance Management in the *JP1/Performance Management User's Guide*.
3. Insert the supplied medium into the machine and execute the installer.

Proceed with installation by following the instructions of the installer that starts.

The following items, which have been set upon the installation of PFM - Manager or PFM - Base, are displayed for your information:

- User information
- Installation folder
- Program folder

4. Click the **Install** button to start the installation process.

2.1.4 Setting up PFM - Agent for Microsoft SQL Server

This section explains the setup that is required before you can use PFM - Agent for Microsoft SQL Server.

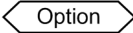
 indicates an item that might be required depending on your operating environment, or an optional item that you can set if you do not wish to use the default.

(1) Registering PFM - Agent for Microsoft SQL Server

To perform integrated management of PFM - Agent for Microsoft SQL Server by using PFM - Manager and PFM - Web Console, you must register PFM - Agent for Microsoft SQL Server in PFM - Manager and PFM - Web Console.

When the version of PFM - Manager is 08-50 and later, you do not need to perform the procedure explained here, because PFM - Agent is automatically registered.

Note, however, that PFM - Agent or PFM - RM that is released earlier than PFM - Manager might require manual registration. For details about whether manual registration is necessary, see the Release Notes for PFM - Manager.

The following figure shows the procedure for registering PFM - Agent for Microsoft SQL Server.

Figure 2–4: Procedure for registering PFM - Agent for Microsoft SQL Server

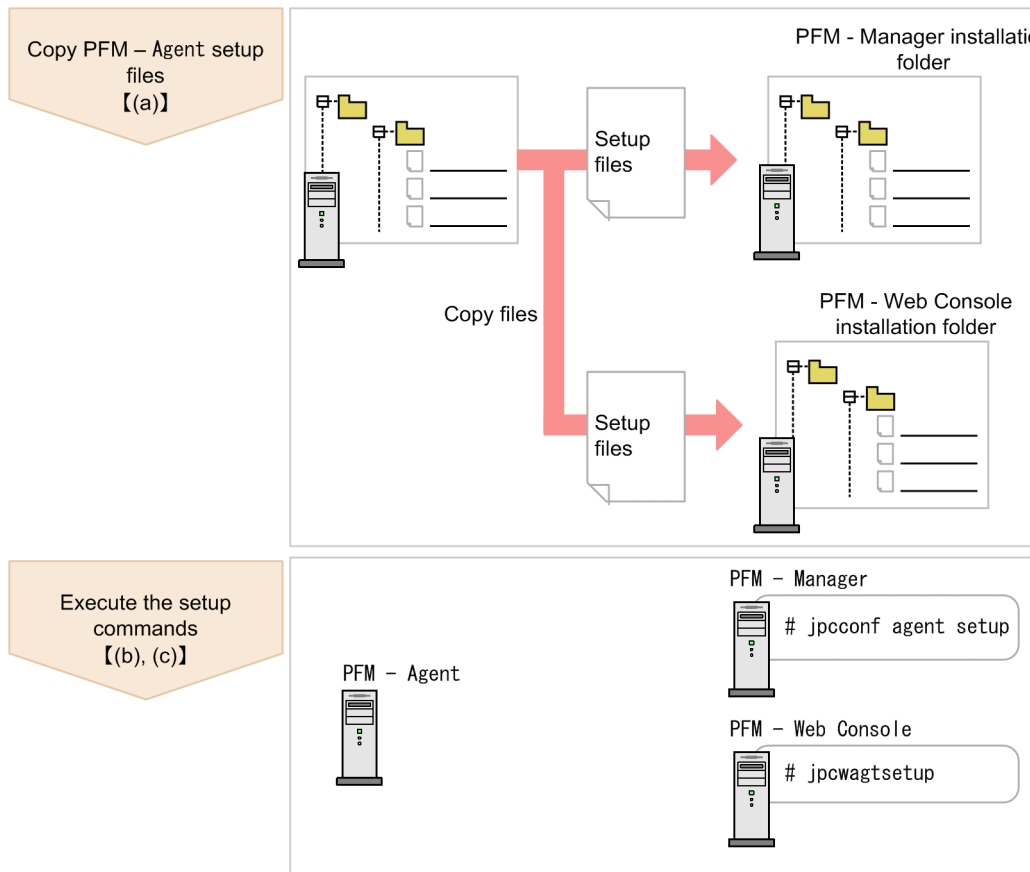

Legend:

[] : Text reference

Important

- Register PFM - Agent for Microsoft SQL Server before setting up an instance environment.
- You do not need to register a new instance of an already registered version of PFM - Agent for Microsoft SQL Server when you add it to the Performance Management system.
- When you have installed different versions of PFM - Agent for Microsoft SQL Server on different hosts, set up the older version before the newer version.
- When you install PFM - Agent for Microsoft SQL Server on the same host as PFM - Manager, the `jpcconf agent setup` command is executed automatically, and the following message is output to the common message log: `KAVE05908-I New agent setup (Pfm-Agent-service-key) ended successfully. (version=version)`. Check the result of command execution in the log file. If execution was unsuccessful, try it again. For details about how to execute commands, see the chapter on commands in the manual *JP1/Performance Management Reference*.
- You must enable shared memory on the Microsoft SQL Server side because PFM - Agent for Microsoft SQL Server uses shared memory to communicate with the Microsoft SQL Server. For a cluster environment, enable TCP/IP on the Microsoft SQL Server side because PFM - Agent for Microsoft SQL Server uses TCP/IP to communicate with Microsoft SQL Server.
- For details about how to enable shared memory and for other detailed information, refer to the Microsoft SQL Server documentation.

- In the Microsoft SQL Server memory settings, do not set the minimum query memory size to less than 1,024 KB (the initial value). If the minimum query memory size is smaller than 1,024 KB, queries for Microsoft SQL Server fail and no data can be collected.
- Registration of PFM - Agent for Microsoft SQL Server creates the *SQL* folder in *Reports* window and *Alarms* window of PFM - Web Console. If the *SQL* file or folder already exists on the *Reports* window, rename the file or folder before registering PFM - Agent for Microsoft SQL Server.

(a) Copy the PFM - Agent for Microsoft SQL Server setup files

Copy the setup files from the host on which you installed PFM - Agent for Microsoft SQL Server to the hosts on which PFM - Manager and PFM - Web Console are installed.

To copy the files:

1. If PFM - Web Console is running, stop it before copying the files.
2. Copy the PFM - Agent for Microsoft SQL Server setup files, in binary mode.

The following table shows the location of the setup files and where they should be copied.

Table 2–2: Setup files to be copied

PFM - Agent for Microsoft SQL Server setup file	Destination		
	PFM program name	OS	Destination folder
<i>installation-folder</i> \setup\jpcagtqw.EXE	PFM - Manager	Windows	<i>installation-folder</i> \setup\
<i>installation-folder</i> \setup\jpcagtqu.Z		UNIX	/opt/jp1pc/setup/
<i>installation-folder</i> \setup\jpcagtqw.EXE	PFM - Web Console	Windows	<i>installation-folder</i> \setup\
<i>installation-folder</i> \setup\jpcagtqu.Z		UNIX	/opt/jp1pcwebcon/setup/

(b) Execute the setup command on the PFM - Manager host

On the PFM - Manager host, execute the following command to set up PFM - Agent for Microsoft SQL Server:

```
jpcconf agent setup -key SQL
```

Although an example of interactive command execution is shown here, the `jpcconf agent setup` command can be also executed non-interactively. For details about the `jpcconf agent setup` command, see the chapter that describes commands in the manual *JP1/Performance Management Reference*.

Important

If any Performance Management programs or services are still running on the local host when you execute the `jpcconf agent setup` command, an error might occur. If an error occurs, make sure that all Performance Management programs and services have completely stopped, and then execute the `jpcconf agent setup` command again.

You can then delete the PFM - Agent for Microsoft SQL Server setup files remaining on the PFM - Manager host.

(c) Execute the setup command on the PFM - Web Console host

On the PFM - Web Console host, execute the following command to set up PFM - Agent for Microsoft SQL Server:

```
jpcwagtsetup
```

You can then delete the PFM - Agent for Microsoft SQL Server setup files remaining on the PFM - Web Console host.

(2) Setting up an instance environment

PFM - Agent for Microsoft SQL Server requires configurations of the instance environment. You can set up multiple instance environments by repeating the procedure for each instance.

- Setting up instance information

This section describes how to set up the instance environment.

(a) Set up instance information

You must specify instance information for the Microsoft SQL Server that is to be monitored by the PFM - Agent for Microsoft SQL Server. Specify instance information on the PFM - Agent host.

The following table lists the instance information items that are to be specified. You should check this information before you start the setup procedure. For details about how to install Microsoft SQL Server, instance information, and user authentication, see the Microsoft SQL Server documentation.

Table 2–3: Instance information of PFM - Agent for Microsoft SQL Server

Item	Description	Specifiable value	Default
Microsoft SQL Server instance name	Displays the instance name of the monitored Microsoft SQL Server.	A character string of 16 or fewer bytes that does not include the multi-byte characters. Specifiable value varies depending on how you install Microsoft SQL Server: If you install Microsoft SQL Server by default: [default] If you install Microsoft SQL Server and specify the instance name: [the instance name you specified] For detail, see about setting up an instance environment.	--
SQL_HOST	Microsoft SQL Server host name for a monitoring target. If the Microsoft SQL Server host is a logical host, specify the logical host.	--	The name of the host on which PFM - Agent for Microsoft SQL Server installed.
SQL_USER#1	Specifies the user name of Microsoft SQL Server used for Microsoft SQL Server authentication.	A character string of 128 or fewer bytes that does not include the multi-byte characters. The user account that has permissions equivalent to sa (the account of a member who has the sysadmin fixed server role). If you specify other user name, see (c) <i>Login permissions of the Microsoft SQL Server</i> . Specify the Microsoft SQL Server user name, by using single-byte characters.	sa

Item	Description	Specifiable value	Default
SQL_PASSWORD#1	Specifies the password of the Microsoft SQL Server user used for Microsoft SQL Server authentication.	The password for SQL_USER.	--
SQL_ERRORLOG	Specify the absolute path of the error log file for the monitored Microsoft SQL Server instance in the PD_EE record and PD_ES record. When no error log file is to be monitored, specify the default value. (Even though the specified value will not be used, this is required because a blank is not allowed.) Even when the file name or path includes single-byte space characters, do not surround it with quotation marks (").	A character string of 512 or fewer bytes that does not include the following characters: <ul style="list-style-type: none"> • Tabs • The following symbols: / , ; * ? " < > 	C:\Program Files\Microsoft SQL Server\MSSQL.1\MSSQL\LOG\ERRORLOG
STARTUP_PENDING#2	Specify the pending time from when PFM - Agent for Microsoft SQL Server starts until it transfers to normal processing. For details about pending function, see 3.2.1(2) ending function during failover	0 to 3,600 (seconds) Pending is not performed when 0 is specified.	0
LOG_PATH#2#3	Specifies the full path name of the folder for storing agent log information. If you specify a path containing space characters, do not enclose the path in quotation marks (").	A character string of 245 or fewer bytes that does not include the following characters: <ul style="list-style-type: none"> • Tabs • The following symbols: / , ; * ? " < > 	<i>installation-folder</i> \agtq\agent \instance-name\log
LOG_SIZE#2	Specifies the maximum size of one agent log file. #4	1 to 32 (megabytes). The minimum recommended value is 16.	16
TIMEOUT#2	Specifies the query timeout value for database access. The value is in seconds.	1 to 3,600 (seconds)	60
LOGIN_TIMEOUT#2	Specifies the access timeout value for database access. The value is in seconds.	1 to 3,600 (seconds)	20
Store Version#5	Specify the version of the Store database to be used. For details about the version of the Store database, see 2.4.3 Updating the Store version to 2.0.	1.0 or 2.0	2.0

Item	Description	Specifiable value	Default
DB_FREE_PERC_OPTION#6#8	Specify how to display the values of the fields related to the percentage of free space in the PD_DS record (the Free % field and the Data Unallocate % field) when its value is negative.	{ Y N } If Y is specified, the value specified for DB_FREE_PERC_NUMBER is displayed. If N is specified, the value of the Free % field and the Data Unallocate % field is displayed as it is when its value is negative.	Y
DB_FREE_PERC_NUMBER#7#8	Specify the value to replace the values of the fields related to the percentage of free space in the PD_DS record (the Free % field and the Data Unallocate % field) when its value is negative. The replacement is enabled only when the value of DB_FREE_PERC_OPTION is Y.	-1 to 999	0
LIMIT_PD_LD_NUMBER#9	Specify the maximum number of collection records for the PD_LD record.	0 to 900,000 If you specify 0, no upper limit is set, and all data is collected.	1000
LIMIT_PD_EE_NUMBER#10	Specify the maximum number of collection records for the PD_EE record. This item takes effect when log data is collected and when monitoring is performed by using alarms. Specify the maximum number of occurrences that can be collected during the collection interval set for Collection Interval. For detail about PD_EE record, see Errorlog Error Detail (PD_EE) of 5. Records. Note: For real-time reports, this item does not take effect, and all error records output to the Microsoft SQL Server error log are collected.	100 to 100,000	1000

Legend:

--: None

#1

Authentication method varies according to the value of SQL_USER you specified. The following table shows the variation on the authentication method. For details about how to install Microsoft SQL Server, instance information, and user authentication, see the Microsoft SQL Server documentation.

Table 2–4: Authentication methods for each user name specified in SQL_USER field

The value of SQL_USER	The value of SQL_PASSWORD	Authentication method
sa	The password for the user sa.	SQL Server Authentication
	None (when no password is set).	
Any alphabetic string	Password for the specified user.	
	Blank (when no password is set).	
A space character	Unnecessary (ignored if specified).	Windows Authentication

Note that when the method is Windows Authentication, PFM - Agent for Microsoft SQL Server uses its service account to obtain authentication. When you use Windows Authentication to monitor Microsoft(R) SQL Server 2012 or later, the server role `sysadmin` is not added to the local system account. Accordingly, add `sysadmin` or prepare another account.

#2 When PFM - Agent for Microsoft SQL Server is upgraded from a version earlier than 08-00, the default values are set.

#3 If you want to change the output folder for agent logs from the default folder, make sure to choose a folder for which write permission is enabled. You cannot delete or change any resource that is under a folder for which WRP resource protection is enabled. Therefore, do not specify the agent log output folder under a folder for which WRP is enabled.

#4 A maximum of 4 agent log files are collected for one instance. Before specifying the `LOG_SIZE` value, make sure that the value satisfies the following condition (this condition also applies when `LOG_PATH` is set to the default):
 $\text{Amount of free space on the drive containing the folder specified in LOG_PATH (MB)} > \text{LOG_SIZE} \times 4$
 If the free disk space is insufficient, the agent log cannot be output. For details about the agent log, see [7.3 Log information](#).

#5 You can specify the Store Version item only when setting up a new instance environment. You cannot specify this item when updating an existing instance environment.

#6 Microsoft SQL Server sometimes defers allocating data, possibly resulting in the update of performance data not to take effect immediately. For this reason, the Free % field and the Data Unallocate % field in the `PD_DS` record may have a negative value. The item specifies whether this value is replaced or not.

#7 If you set the Free % field and the Data Unallocate % field as a measured parameter of the alarm condition, specify the value depending on the operation environment.
 If you want to give the alarm:
 -The value you specify in this field must be above the threshold of the abnormal and warning condition.
 If you do not want to give the alarm:
 -The value you specify in the field must be below the threshold of the abnormal and warning condition.

#8 If the value of the Free % field is replaced when its value is negative, the "KAVF21847-I" message is output to the agent log, whereas if the value of the Data Unallocate % field is replaced, the "KAVF21851-I" message is output to the agent log.

#9 If you collect the Lock Details (`PD_LD`) record when a large number of transactions or access locks have occurred in the Microsoft SQL Server, the following events might occur.
 - The space in the Store database increases.
 - Collection takes time, and until the collection has been completed, the collection of other records is skipped.
 - A large amount of memory is consumed.
 For example, if the number of locks temporarily increases during backup of the Microsoft SQL Server databases, you can set an upper limit for the Lock Detail (`PD_LD`) record to reduce system load.
 The setting value must be greater than the maximum number of locks occurring during normal operation. You can check the number of locks by using either of the following methods:
 - Check the normal log in the agent logs.

The number of locks is provided by the following message:

```
KAVF21807-I Getting record ended = LD -> Storing started [ count = number-of-records ]
```

- Execute an SQL statement to check the current number of locks.

You can check the number of locks by executing the SQL statement described in the PD_LD row in Table A-1 in *A.4 Calculating the number of instances for records*.

#10

If a failure occurs in Microsoft SQL Server, many records about the same error might be output to the Microsoft SQL Server error log continuously.

If an attempt is made to collect the Errorlog Error Detail (PD_EE) record in this situation, the following problems might occur:

- The space in the Store database increases.

- Collection takes time, and until the collection has been completed, the collection of other records is skipped.

- A large amount of memory is consumed.

By using this item to set the upper limit, you can reduce the load on the system. We recommend that you set 1,000 as the upper limit.

Notes:

- If no instance environment has been set up, the service of PFM - Agent for Microsoft SQL Server does not start.
- When using the `jpcinssetup` command to create an instance environment, the command ends normally even if you specify an instance name that does not exist on the Microsoft SQL Server. However, when you start collecting records, the KAVF21400-W message is output to the common message log and the Tuning Manager server cannot connect to the monitored Microsoft SQL Server. In this case, specify the correct instance name, then run the `jpcinssetup` command again.

To build an instance environment using the `jpcconf inst setup` command:

1. Specify a service key and an instance name, and then execute the `jpcconf inst setup` command.

Execute the command specified as follows:

```
jpcconf inst setup -key SQL -inst instance-name
```

The instance-name to be specified should be as follows, depending on the installation method for Microsoft SQL Server:

- When default installation of Microsoft SQL Server was performed:

You must specify default for the instance-name (to monitor default instances), as follows:

```
jpcconf inst setup -key SQL -inst default
```

Note that names other than default cannot be specified.

- When installation of Microsoft SQL Server was performed with a specified instance name:

You must specify the instance-name so that it can be recognized as the instance of the Microsoft SQL Server. Specify the instance name that was entered at installation of the Microsoft SQL Server (the instance name of the Microsoft SQL Server to be monitored). If Microsoft SQL Server was installed with the instance named SQL1, specify the instance-name as follows:

```
jpcconf inst setup -key SQL -inst SQL1
```

For details about the `jpcconf inst setup` command, see the chapter that describes commands in the manual *JPI/Performance Management Reference*.

2. Set up the instance information for PFM - Agent for Microsoft SQL Server.

Enter the values for the items listed in [Table 2-3](#) as prompted by the command. All items are mandatory. To use the default value displayed for an item, only press the **Enter** key.

When all values have been entered, the instance environment is created. If you want to change the instance information, re-execute the `jpcconf inst setup` command to update the instance environment. For details about updating an instance environment, see [2.4.2 Updating an instance environment](#).

The instance environment that is built is described as follows:

- The organization of the instance environment folder

The following folder configuration of the instance environment that is built.

For physical host: *installation-folder*\agtq

For logical host: *environment-folder*#\jplpc\agtq

#

Environment-folder is the folder that is created on the shared disk when setting up the logical host.

The following table lists and describes the folder configuration of the instance environment that is built.

Table 2–5: Folder configuration of the instance environment

Folder name and File name		Descriptions	
agent	<i>instance-name</i>	jpcagt.ini	Agent Collector service startup initialization file
		jpcagt.ini.model#	Model file for the Agent Collector service startup initialization file
		log	Storage folder for log files
store	<i>instance-name</i>	jpcsto.ini	Agent Store service startup initialization file
		jpcsto.ini.model#	Model file for the Agent Store service startup initialization file
		*.DAT	Data model definition file
		dump	Export destination folder
		import	Standard database import destination folder (for Store version 2.0)
		backup	Backup destination folder
		log	Storage folder for log files
		partial	Standard database partial backup destination folder (for Store version 2.0)
		STPD	Performance data storage folder for the PD record type (for Store version 2.0)
		STPI	Performance data storage folder for the PI record type (for Store version 2.0)

#

This file is used to reset all values to the initial values set when the instance environment was created.

- Service ID for the instance environment

The service ID for the instance environment is shown as follows.

- Agent Collector service: QA*instance-number instance-name* [*host-name*]
- Agent Store service: QS*instance-number instance-name* [*host-name*]

In PFM - Agent for Microsoft SQL Server, the *instance name* specified in the `jpcconf inst setup` command is displayed.

For example, if you execute the command with *host name* host1 and *instance name* default, the service IDs will be as follows:

- Agent Collector service: QA1default [host1]
- Agent Store service: QS1default [host1]

For details about the service ID, see the naming rules described in Appendix in the *JPI/Performance Management Planning and Configuration Guide*.

- Windows service name for the instance environment

The Windows service name for the instance environment is described as follows:

- Agent Collector service: PFM - Agent for Microsoft(R) SQL Server *instance-name*[*logical-host-name*]
- Agent Store service: PFM - Agent Store for Microsoft(R) SQL Server *instance-name* [*logical-host-name*]

In PFM - Agent for Microsoft SQL Server, the *instance name* specified in the `jpcconf inst setup` command is displayed.

For example, when the *logical host name* is `lhost` and the *instance name* is `default`, the service name will be:

- Agent Collector service: PFM - Agent for Microsoft(R) SQL Server `default[lhost]`
- Agent Store service: PFM - Agent Store for Microsoft(R) SQL Server `default[lhost]`

For details about the Windows service names for logical host operation, in the *JPI/Performance Management User's Guide*, see the chapters explaining setup and operation for cluster systems.

(b) Using Windows authentication

When the instance environment is built up, the login account for the PFM - Agent for Microsoft SQL Server service is created as the local system account.

If you select Windows authentication for the `SQL_USER` item of the instance information, the logged-in account of the PFM - Agent for Microsoft SQL Server service is used for authentication.

If you prepare another account, the account needs to be able to be used to connect with the monitoring target Microsoft SQL Server. To check whether the account you specify can log in as the service to the monitoring target host, use `Microsoft SQL Server Management Studio` or `sqlcmd` command. For details, see your Microsoft SQL Server documentation.

To change the account:

1. From the Windows **Start** menu, choose **Administrative Tools** and then **Service**.
2. In the Detail pane, right-click the PFM - Agent for Microsoft(R) SQL Server *instance-name* **Service** window and then click **Properties**.
3. Click the **Log On** tab, specify the **Account**, and type the password.

For details, see the documentation for your OS.

Note:

Do not change the account of PFM - Agent Store for Microsoft(R) SQL Server *instance-name* service.

(c) Login permissions of the Microsoft SQL Server

To operate PFM - Agent for Microsoft SQL Server, you need a Microsoft SQL Server login (database user) with certain permissions.

The following shows the permissions required for PFM - Agent for Microsoft SQL Server to collect the performance information of the Microsoft SQL Server Database:

If the sysadmin fixed server role can be granted:

You can use the user account with the sysadmin fixed server role granted to collect all the records.

If the sysadmin fixed server role cannot be granted:

The user account used for monitoring needs the CONNECT permission for all the databases, and also requires the permissions shown in the table below.

If you want to collect PD_SQL records, the sysadmin fixed server role is required. If this role is not granted, you cannot collect PD_SQL records.

Table 2–6: The required permissions for PFM - Agent for Microsoft SQL Server to collect performance information of Microsoft SQL Server Database

Permissions	Description
server role	The server permission that each object used for collecting records requires. (For details, see Table 2-7 .)
Database permissions or object permissions	<p>Either of the following permissions is required:</p> <ul style="list-style-type: none"> Database permissions Some database permissions are required for each record to be collected. (For details, see Table 2-8.) Object permissions Some object permissions are required for each object used for collecting records. (To connect with a database of Microsoft SQL Server version 2014 or earlier, see Table 2-9, and to connect with a database of Microsoft SQL Server version 2016 or later, see Table 2-10.)

If you can grant permissions to the database, see *If you want to grant database permissions in Database permissions or object permissions* to assign the required permissions. If you want to grant more detailed object-based permissions than database permissions, see *If you want to grant object permissions in Database permissions or object permissions* to grant the required permissions.

■ **server role**

The following table shows the server permissions required for user accounts used for monitoring to collect records for PFM - Agent for Microsoft SQL Server.

If you want to collect PD_SQL records, the sysadmin fixed server role is required. If this role is not granted, you cannot collect PD_SQL records.

Table 2–7: Server permissions required for collecting records for PFM - Agent for Microsoft SQL Server

Records	Server permissions required for collecting records	
	If SQL Server version 2014 or earlier is monitored	If SQL Server version 2016 or later is monitored
SQL Text (PD_SQL)	Records cannot be collected.	
<ul style="list-style-type: none"> Database Detail (PD_DD) Database Space Detail (PD_DS) Server Space Detail (PD_SS) Server Space Interval (PI_SI) Database Interval (PI_DI) 	<ul style="list-style-type: none"> VIEW SERVER STATE VIEW ANY DEFINITION 	<ul style="list-style-type: none"> VIEW SERVER STATE VIEW ANY DEFINITION VIEW ANY DATABASE
<ul style="list-style-type: none"> Lock Detail (PD_LD) Process Detail (PD_PDET) User Process Detail (PI_USER) 	<ul style="list-style-type: none"> VIEW SERVER STATE VIEW ANY DEFINITION 	
<ul style="list-style-type: none"> Server Detail (PD) 	<ul style="list-style-type: none"> VIEW SERVER STATE 	<ul style="list-style-type: none"> VIEW SERVER STATE VIEW ANY DATABASE

Records	Server permissions required for collecting records	
	If SQL Server version 2014 or earlier is monitored	If SQL Server version 2016 or later is monitored
<ul style="list-style-type: none"> • Database Replication Detail (PD_RD) • Replication Summary Detail (PD_RS) 	<ul style="list-style-type: none"> • VIEW SERVER STATE 	<ul style="list-style-type: none"> • VIEW SERVER STATE • VIEW ANY DATABASE
<ul style="list-style-type: none"> • Global Server Summary (PI) • Global Server Summary 2 (PI_PI2) • Licensing Detail (PD_LIC) • User-Defined Counter Overview (PI_UCTR) • Server Overview (PI_SERV) • Server Overview 2 (PI_SRV2) • Server Locks Detail (PD_LOCK) • Transaction Log Overview (PI_TLOG) 	<ul style="list-style-type: none"> • VIEW SERVER STATE 	
<ul style="list-style-type: none"> • Replication Published Database Overview (PI_RPDB) • Procedure Cache Detail (PD_PCAC) • Config Detail (PD_CD) • Job History Detail (PD_JH) • Errorlog Error Detail (PD_EE) • Errorlog Summary Detail (PD_ES) • Instance Availability (PD_IA) 	No server role permission is required.	

■ Database permissions or object permissions

• If you want to grant database permissions

Grant necessary database permissions to the user account used for monitoring for each record as shown in the following table.

Table 2–8: Database permissions required for collecting records for PFM - Agent for Microsoft SQL Server

Records	Database permissions required for collecting records
PD_SQL	Records cannot be collected.
PD_PCAC	Grant the db_owner database role for the master database.
PI_RPDB	<ul style="list-style-type: none"> • Grant the db_owner database role for the master database. • Grant the SELECT permission for all the databases.
PD_DS, PD_SS, PI_SI, PI_DI, PD_RS	<ul style="list-style-type: none"> • Grant the SELECT permission for all the databases. • Grant the EXEC permission for the master database.
PD_DD, PD_RD, PD_LD	Grant the SELECT permission for all the databases.
PD_CD	Grant the SELECT permission for the master database.
PD, PI, PI_PI2, PD_LIC, PI_UCTR, PI_SERV, PI_SRV2, PD_LOCK, PD_PDET, PD_USER	Grant the SELECT permission for the master database.
PD_JH	Grant the SELECT permission for the msdb database.

Records	Database permissions required for collecting records
PD_EE, PD_ES, PD_IA, PI_TLOG	No database permission is required.

• **If you want to grant object permissions**

Grant necessary object permissions to the user account used for monitoring for each record as shown in the following table.

If you want to connect with the database of Microsoft SQL Server version 2014 or earlier, see [Table 2-9](#), and if you want to connect with Microsoft SQL Server version 2016 or later, see [Table 2-10](#).

Note that if you want to collect PD_PCAC or PI_RPDB records, the db_owner database role for the master database is required. If this role is not granted, you cannot collect PD_PCAC or PI_RPDB records.

Table 2–9: The required permissions for each object which PFM - Agent for Microsoft SQL Server uses when collecting records(SQL Server version 2014 or earlier)

Records	Object permissions granted to users required for collecting records
PD_SQL, PD_PCAC, PI_RPDB	Records cannot be collected.
PD_DD	<ul style="list-style-type: none"> • Grant the SELECT permission for the following objects in the master database: <ul style="list-style-type: none"> - sysdatabases - sysprocesses - syslogins - sysusers - spt_values - sysfiles - syslockinfo - sysperfmfinfo • Grant the EXEC permission for the following objects in the master database: <ul style="list-style-type: none"> - sp_databases (In case of not executing the sp_inst.sql script) - A4QHITACHIPROCSPDATABASES (In case of executing the sp_inst.sql script) • Grant the SELECT permission for the following object in the msdb database: <ul style="list-style-type: none"> - backupset • Grant the SELECT permission for the following object in all the databases: <ul style="list-style-type: none"> - sys.indexes
PD_DS, PD_SS, PI_SI	<ul style="list-style-type: none"> • Grant the SELECT permission for the following objects in the master database: <ul style="list-style-type: none"> - sysdatabases - spt_values - sysfiles • Grant the EXEC permission for the following objects in the master database: <ul style="list-style-type: none"> - sp_databases (In case of not executing the sp_inst.sql script) - A4QHITACHIPROCSPDATABASES (In case of executing the sp_inst.sql script) • Grant the SELECT permission for the following object in the msdb database: <ul style="list-style-type: none"> - backupset • Grant the SELECT permission for the following object in all the databases: <ul style="list-style-type: none"> - sys.indexes - sys.allocation_units - sys.partitions - sys.internal_tables
PI_DI	<ul style="list-style-type: none"> • Grant the SELECT permission for the following objects in the master database: <ul style="list-style-type: none"> - sysdatabases - sysprocesses

Records	Object permissions granted to users required for collecting records
PI_DI	<ul style="list-style-type: none"> - syslogins - sysusers - spt_values - sysfiles - sysperfinfo • Grant the EXEC permission for the following objects in the master database: <ul style="list-style-type: none"> - sp_databases (In case of not executing the sp_inst.sql script) - A4QHITACHIPROCSPDATABASES (In case of executing the sp_inst.sql script) • Grant the SELECT permission for the following object in the msdb database: <ul style="list-style-type: none"> - backupset • Grant the SELECT permission for the following object in all the databases: <ul style="list-style-type: none"> - sys.indexes - sys.allocation_units - sys.partitions - sys.internal_tables
PD_LD	<ul style="list-style-type: none"> • Grant the SELECT permission for the following objects in the master database: <ul style="list-style-type: none"> - sysprocesses - syslogins - sysusers - sys.dm_tran_locks - syslockinfo • Grant the SELECT permission for the following object in all the databases: <ul style="list-style-type: none"> - sys.all_objects
PD_PDET	<ul style="list-style-type: none"> • Grant the SELECT permission for the following objects in the master database: <ul style="list-style-type: none"> - syslockinfo - sysprocesses - syslogins - sysusers
PD_USER	<ul style="list-style-type: none"> • Grant the SELECT permission for the following objects in the master database: <ul style="list-style-type: none"> - sysprocesses - syslogins - sysusers - syslockinfo
PD	<ul style="list-style-type: none"> • Grant the SELECT permission for the following objects in the master database: <ul style="list-style-type: none"> - sysdatabases - sysprocesses - syslogins - sysusers - spt_values - syslockinfo - sysperfinfo • Grant the SELECT permission for the following objects in the msdb database: <ul style="list-style-type: none"> - backupset
PD_RD	<ul style="list-style-type: none"> • Grant the SELECT permission for the following objects in the master database: <ul style="list-style-type: none"> - sysdatabases - spt_values • Grant the SELECT permission for the following objects in the msdb database: <ul style="list-style-type: none"> - backupset • Grant the SELECT permission for the following objects in all the database:

Records	Object permissions granted to users required for collecting records
PD_RD	<ul style="list-style-type: none"> - MSdistribution_history - sys.indexes - sysarticles - syspublications - syssubscriptions - all_objects
PD_RS	<ul style="list-style-type: none"> • Grant the SELECT permission for the following objects in the master database: <ul style="list-style-type: none"> - sysdatabases - spt_values • Grant the EXEC permission for the following objects in the master database: <ul style="list-style-type: none"> - sp_databases(In case of not executing the sp_inst.sql script) - A4QHITACHIPROCSPPDATABASIS (In case of executing the sp_inst.sql script) • Grant the SELECT permission for the following objects in the msdb database: <ul style="list-style-type: none"> - backupset • Grant the SELECT permission for the following objects in all the database: <ul style="list-style-type: none"> - MSdistribution_history - sys.indexes - sysarticles - syspublications - syssubscriptions - all_objects
PI, PI_PI2, PD_LIC, PI_UCTR, PI_SERV, PI_SRV2	<ul style="list-style-type: none"> • Grant the SELECT permission for the following objects in the master database: <ul style="list-style-type: none"> - sysperfinfo
PD_LOCK	<ul style="list-style-type: none"> • Grant the SELECT permission for the following objects in the master database: <ul style="list-style-type: none"> - syslockinfo - sysprocesses - syslogins - sysusers
PD_CD	<ul style="list-style-type: none"> • Grant the EXEC permission for the following objects in the master database: <ul style="list-style-type: none"> - sp_configure
PD_JH	<ul style="list-style-type: none"> • Grant the SELECT permission for the following objects in the msdb database: <ul style="list-style-type: none"> - sysjobhistory - sysjobsteps - sysjobs - all_objects
PI_TLOG, PD_EE, PD_ES, PD_IA	All the users can execute the object.

Table 2–10: The required permissions for each object which PFM - Agent for Microsoft SQL Server uses when collecting records(SQL Server version 2016 or later)

Records	Object permissions granted to users required for collecting records
PD_SQL, PD_PCAC, PI_RPDB	Records cannot be collected.
PD_DD	<ul style="list-style-type: none"> • Grant the SELECT permission for the following objects in the master database: <ul style="list-style-type: none"> - sys.databases - sys.dm_tran_locks - sys.dm_exec_requests - sys.dm_exec_sessions - sys.dm_os_tasks

Records	Object permissions granted to users required for collecting records
PD_DD	<ul style="list-style-type: none"> - sys.dm_os_waiting_tasks - sys.server_principals - sys.database_principals - spt_values - sys.dm_os_performance_counters • Grant the SELECT permission for the following objects in the msdb database: <ul style="list-style-type: none"> - backupset • Grant the SELECT permission for the following objects in all the database: <ul style="list-style-type: none"> - sys.indexes
PD_DS, PD_SS, PI_SI	<ul style="list-style-type: none"> • Grant the SELECT permission for the following objects in the master database: <ul style="list-style-type: none"> - sys.databases - sys.database_files - spt_values • Grant the SELECT permission for the following objects in the msdb database: <ul style="list-style-type: none"> - backupset • Grant the SELECT permission for the following objects in all the database: <ul style="list-style-type: none"> - sys.indexes - sys.allocation_units - sys.partitions - sys.internal_tables
PI_DI	<ul style="list-style-type: none"> • Grant the SELECT permission for the following objects in the master database: <ul style="list-style-type: none"> - sys.databases - spt_values - sys.dm_exec_requests - sys.dm_exec_sessions - sys.dm_os_tasks - sys.dm_os_waiting_tasks - sys.server_principals - sys.database_principals - sys.database_files - sys.dm_os_performance_counters • Grant the SELECT permission for the following objects in the msdb database: <ul style="list-style-type: none"> - backupset • Grant the SELECT permission for the following objects in all the database: <ul style="list-style-type: none"> - sys.indexes - sys.allocation_units - sys.partitions - sys.internal_tables
PD_LD	<ul style="list-style-type: none"> • Grant the SELECT permission for the following objects in the master database: <ul style="list-style-type: none"> - sys.dm_tran_locks - sys.dm_exec_requests - sys.dm_exec_sessions - sys.dm_os_tasks - sys.dm_os_waiting_tasks - sys.server_principals - sys.database_principals • Grant the SELECT permission for the following objects in all the database: <ul style="list-style-type: none"> - sys.all_objects - sys.partitions
PD_PDET	<ul style="list-style-type: none"> • Grant the SELECT permission for the following objects in the master database:

Records	Object permissions granted to users required for collecting records
PD_PDET	<ul style="list-style-type: none"> - sys.dm_tran_locks - sys.dm_exec_requests - sys.dm_exec_sessions - sys.dm_os_tasks - sys.dm_os_waiting_tasks - sys.server_principals - sys.database_principals
PD_USER	<ul style="list-style-type: none"> • Grant the SELECT permission for the following objects in the master database: <ul style="list-style-type: none"> - sys.dm_tran_locks - sys.dm_exec_requests - sys.dm_exec_sessions - sys.dm_os_tasks - sys.dm_os_waiting_tasks - sys.server_principals - sys.database_principals - sys.server_role_members
PD	<ul style="list-style-type: none"> • Grant the SELECT permission for the following objects in the master database: <ul style="list-style-type: none"> - sys.databases - sys.dm_tran_locks - sys.dm_exec_requests - sys.dm_exec_sessions - sys.dm_os_tasks - sys.dm_os_waiting_tasks - sys.server_principals - sys.database_principals - sys.dm_os_performance_counters - spt_values • Grant the SELECT permission for the following objects in the msdb database: <ul style="list-style-type: none"> - backupset
PD_RD	<ul style="list-style-type: none"> • Grant the SELECT permission for the following objects in the master database: <ul style="list-style-type: none"> - sys.databases - spt_values • Grant the SELECT permission for the following objects in all the database: <ul style="list-style-type: none"> - MSdistribution_history - sys.indexes - sysarticles - syspublications - syssubscriptions - sys.all_objects
PD_RS	<ul style="list-style-type: none"> • Grant the SELECT permission for the following objects in the master database: <ul style="list-style-type: none"> - sys.databases - spt_values • Grant the SELECT permission for the following objects in all the database: <ul style="list-style-type: none"> - MSdistribution_history - sys.indexes - sysarticles - syspublications - syssubscriptions - sys.all_objects

Records	Object permissions granted to users required for collecting records
PI, PI_PI2, PD_LIC, PI_UCTR, PI_SERV, PI_SRV2	<ul style="list-style-type: none"> Grant the SELECT permission for the following objects in the master database: <ul style="list-style-type: none"> - sys.dm_os_performance_counters
PD_LOCK	<ul style="list-style-type: none"> Grant the SELECT permission for the following objects in the master database: <ul style="list-style-type: none"> - sys.dm_tran_locks - sys.dm_exec_requests - sys.dm_exec_sessions - sys.dm_os_tasks - sys.dm_os_waiting_tasks - sys.server_principals - sys.database_principals
PD_CD	<ul style="list-style-type: none"> Grant the EXEC permission for the following objects in the master database: <ul style="list-style-type: none"> - sp_configure
PD_JH	<ul style="list-style-type: none"> Grant the SELECT permission for the following objects in the msdb database: <ul style="list-style-type: none"> - sysjobhistory - sysjobsteps - sysjobs - sys.all_objects
PI_TLOG, PD_EE, PD_ES, PD_IA	All ther users can execute the object.

(3) Registering the A4QHITACHIPROCSPDATABASES Stored Procedure

Option

Register the A4QHITACHIPROCSPDATABASES stored procedure in the master database of the monitored Microsoft SQL Server instance.

- A4QHITACHIPROCSPDATABASES**

PFM - Agent for Microsoft SQL Server uses this stored procedure to acquire a list of database names and sizes from Microsoft SQL Server. If Microsoft SQL Server version 2014 or earlier is monitored and the size of the database in the instance is 2 terabytes or larger, PFM - Agent for Microsoft SQL Server can acquire information only when a stored procedure has been registered.

If Microsoft SQL Server version 2016 or later is monitored, you need not register the stored procedure.

Note:

The A4QHITACHIPROCSPDATABASES stored procedure cannot be registered if a stored procedure table view that has the same name already exists in the `master` database of the monitored Microsoft SQL Server instance.

The A4QHITACHIPROCSPDATABASES stored procedure can be registered by using the `sp_inst.sql` script provided by PFM - Agent for Microsoft SQL Server. To use the `sp1cmd` utility to register the stored procedure:

1. Set up an environment in which the `sp1cmd` utility of Microsoft SQL Server can be executed.

The `sp1cmd` utility is provided by Microsoft. For details about the environment settings for Microsoft SQL Server, see your Microsoft SQL Server documentation.

2. Move to the folder in which the `sp_inst.sql` script is located.

The script is located in the following folder:

```
installation-folder\agtq\sql
```

3. Execute the script with the monitored Microsoft SQL Server instance specified.

The command line for executing the `sp_inst.sql` script depends on the type of the monitored Microsoft SQL Server instance and the method of authentication used for connecting to Microsoft SQL Server. The following shows the command line for each condition.

- *When the default instance of Microsoft SQL Server is being monitored*

Authentication method	Command line for executing the <code>sp_inst.sql</code> script
SQL Server	<code>splcmd -S host-name -U user-name -P password -d master -i sp_inst.sql #</code>
Windows	<code>splcmd -S host-name -E -d master -i sp_inst.sql #</code>

- *When a named instance of Microsoft SQL Server is being monitored*

Authentication method	Command line for executing the <code>sp_inst.sql</code> script
SQL Server	<code>splcmd -S host-name\instance-name -U user-name -P password -d master -i sp_inst.sql #</code>
Windows	<code>splcmd -S host-name\instance-name -E -d master -i sp_inst.sql #</code>

#

The following describes the items that the user specifies:

host-name: Name of the host on which the monitored Microsoft SQL Server instance operates

instance-name: Name of the monitored Microsoft SQL Server instance

user-name: `sa` or a user account that has permissions equivalent to `sa` (the account of a member who has the `sysadmin` fixed server role)

password: Password for the specified user name

For details about how to delete the `A4QHITACHIPROCSPDATABASES` Stored Procedure, see [I. Deleting the A4QHITACHIPROCSPDATABASES Stored Procedure](#).

(4) Specifying network settings Option

You must specify the network settings according to the configuration in which Performance Management will be used.

You can specify the following two network settings:

- *IP addresses*

Set the IP addresses when using Performance Management in a network environment in which multiple LANs are connected. You can set multiple IP addresses by defining the host names and IP addresses in the `jpchosts` file. Use the same `jpchosts` file throughout the Performance Management system.

For details, see the chapter on installation and setup in the *JPI/Performance Management Planning and Configuration Guide*.

- *Port numbers*

Specify the port numbers to be used by Performance Management. To avoid conflicts, use the same port numbers and service names throughout the Performance Management system.

For details about setting port numbers, see the chapter on installation and setup in the *JPI/Performance Management Planning and Configuration Guide*.

(5) Changing the size of log files Option

Performance Management outputs its operating status to a set of proprietary log files called the *common message log*. By default, the common message log consists of two 2,048 KB files. Setting is required only if you want to change the default file size.

For details, see the chapter on installation and setup in the *JP1/Performance Management Planning and Configuration Guide*.

(6) Changing the storage location of performance data Option

Setting is required only if you want to change the folders used for saving, backing up, exporting, or importing the database of performance data managed by PFM - Agent for Microsoft SQL Server.

By default, performance data is saved in the following locations:

- Save folder: `installation-folder\agtq\store\instance-name\`
- Backup folder: `installation-folder\agtq\store\instance-name\backup\`
- Partial backup folder#: `installation-folder\agtq\store\instance-name\partial\`
- Export folder: `installation-folder\agtq\store\instance-name\dump\`
- Import folder#: `installation-folder\agtq\store\instance-name\import\`

Note:

For the default save destination for logical host operation, replace *installation-folder* with *environment-folder* `\jplpc\`.

#

This folder can be set only when the Store version is 2.0.

For details, see [2.4.1 Changing the storage location of performance data](#).

(7) Setting the connection-target PFM - Manager of PFM - Agent for Microsoft SQL Server

On the host where PFM - Agent for Microsoft SQL Server is installed, you must specify the PFM - Manager that manages that PFM - Agent for Microsoft SQL Server.

Use the `jpcconf mgrhost define` command to set the connection-target PFM - Manager.

Important

Notes:

- When multiple instances of PFM - Agent are installed on a single host, you can specify only one PFM - Manager as their connection target. You cannot have different instances of PFM - Manager as the connection target for the PFM - Agent instances.
- If PFM - Agent for Microsoft SQL Server and PFM - Manager are installed on the same host, the PFM - Manager on the local host is the connection-target PFM - Manager. You cannot use PFM - Manager on another host as the connection target.

To specify the connection-target PFM - Manager:

1. Stop all Performance Management programs and services.

Before executing a setup operation, stop all Performance Management programs and services on the local host if they are active. For details about how to stop services, see the chapter explaining how to start and stop Performance Management in the *JP1/Performance Management User's Guide*.

If any Performance Management programs or services are running when you execute the `jpccconf mgrhost define` command, you will be prompted by a message to stop the programs or services.

2. Execute the `jpccconf mgrhost define` command with the host name of the connection-target PFM - Manager host specified.

For example, if the connection-target PFM - Manager is on host `host01`, specify the following:

```
jpccconf mgrhost define -host host01
```

Although an example of interactive command execution is shown here, the `jpccconf mgrhost define` command can be also executed non-interactively. For details about the `jpccconf mgrhost define` command, see the chapter that describes commands in the manual *JP1/Performance Management Reference*.

(8) Outputting the action logs

You need to perform this setting if you want to output action logs when PFM - Agent for Microsoft SQL Server gives alarms. Action logs are the historical information output with the alarms exceeding threshold values (such as the alarms concerning system load).

For details about how to set up, see *J. Outputting Action Log Information*.

2.2 Setup cancellation and uninstallation

This section describes the procedures for uninstalling or canceling setup of PFM - Agent for Microsoft SQL Server.

2.2.1 Cautionary notes on setup cancellation and uninstallation

Note the following when uninstalling or canceling setup of PFM - Agent for Microsoft SQL Server.

(1) Note on OS user permission required to uninstall PFM - Agent

Before you uninstall PFM - Agent for Microsoft SQL Server, make sure that you have logged on a member of the Administrators group.

(2) Note on network configuration

When you uninstall a Performance Management program, the port numbers defined in the `services` file will remain in the file.

(3) Notes on programs

- If you uninstall a Performance Management program while another Performance Management program or service or other program that references Performance Management files (for example, Windows Event Viewer) is running, some files or folders might remain in the system. If files remain, manually delete everything under the installation folder.
- If you uninstall a Performance Management program while another Performance Management program or service or other program that references Performance Management files (for example, Windows Event Viewer) is running, you might be prompted to restart the system. If this happens, restart the system to complete the uninstallation process.
- If both PFM - Base and PFM - Agent for Microsoft SQL Server are installed on a host, you cannot uninstall PFM - Base without first uninstalling PFM - Agent for Microsoft SQL Server. In this case, uninstall PFM - Agent for Microsoft SQL Server and then PFM - Base in that order. The same applies when both PFM - Manager and PFM - Agent for Microsoft SQL Server are installed on a host. You cannot uninstall PFM - Manager without first uninstalling PFM - Agent for Microsoft SQL Server. In this case, uninstall PFM - Agent for Microsoft SQL Server and then PFM - Manager in that order.

(4) Notes on services

Uninstalling PFM - Agent for Microsoft SQL Server does not delete the information about the service from the list that appears when you execute the `jpctool service list` command. For details about deleting the information about the service, see the section about deleting the service in the chapter on installation and setup in the *JPI/Performance Management Planning and Configuration Guide*. When you want to update the PFM - Web Console host to reflect the deletion of service information, you need to execute the `jpctool service sync` command to synchronize the agent information of the PFM - Manager host and that of the PFM - Web Console host.

(5) Other notes

- Before uninstalling a program of the Performance Management products from a host on which PFM - Web Console has been installed, you must close all windows of Web browser.
- Before you start uninstallation, use the `jpccnf inst setup` command or PFM - Web Console to check the agent log output directory. If this directory has been changed from the default directory (*installation-folder\agtq*

`\agent\instance-name\log\`), the agent log files remain after uninstallation. Manually delete these files after uninstallation.

2.2.2 Procedure for canceling setup

This subsection describes how to cancel setup of PFM - Agent for Microsoft SQL Server.

(1) Canceling setup of an instance environment

Canceling setup of an instance environment involves the tasks listed below. To cancel setup of multiple instance environments, you must repeat the procedure for each environment.

- Deleting an instance environment

To cancel the setup of an instance environment:

(a) Delete an instance environment

Check the instance name and delete the instance environment. Delete an instance environment on the PFM - Agent host.

To check the instance name, use the `jpccconf inst list` command. To delete an instance environment that has been created, use the `jpccconf inst unsetup` command.

To delete an instance environment:

1. Check the instance name.

Execute the `jpccconf inst list` command specified with the service key that indicates PFM - Agent for Microsoft SQL Server.

```
jpccconf inst list -key SQL
```

For example, if the instance name is SQL1, the command displays SQL1.

2. Stop all active PFM - Agent for Microsoft SQL Server services in the instance environment.

For details about how to stop services, see the chapter on starting and stopping Performance Management in the *JPI/Performance Management User's Guide*.

3. Delete the instance environment.

Execute the `jpccconf inst unsetup` command specified with the service key that indicates PFM - Agent for Microsoft SQL Server and the instance name.

For example, if the instance name is SQL1, use the following command line:

```
jpccconf inst unsetup -key SQL -inst SQL1
```

When the `jpccconf inst unsetup` command terminates successfully, the folders created as the instance environment are deleted, as well as the service IDs and Windows services.

If you specify default for the instance-name, the instance environment for monitoring the default Microsoft SQL Server instance will be deleted.

Note:

Canceling setup of an instance environment does not delete the service information that is displayed with the `jpctool service list` command. Use the `jpctool service delete` command to delete service information, and then restart PFM - Manager.

If you want to update the PFM - Web Console host to reflect the deletion of instance environment, you need to execute the `jpctool service sync` command to synchronize the agent information of the PFM - Manager host and that of the PFM - Web Console host.

- Instance name: SQL1
- Host name: host1
- Service ID of the Remote Monitor Collector service: QA1SQL[host1]
- Service ID of the Remote Monitor Store service: QS1SQL[host1]

```
jpctool service delete -id Q?1SDC[host01] -host host01
```

For details about the command, see the chapter on commands in the manual *JP1/Performance Management Reference*.

2.2.3 Procedure for uninstallation

To uninstall PFM - Agent for Microsoft SQL Server:

1. On the host from which PFM - Agent for Microsoft SQL Server is to be uninstalled, log on as a member of the Administrators group.
2. Stop all Performance Management programs and services on the local host.
Display the service information to confirm that no programs are running.
Stop all Performance Management programs and services running on the local host. This includes services running on both physical and logical hosts.
For details about how to display service information and to stop services, see the chapter on starting and stopping Performance Management in the *JP1/Performance Management User's Guide*.
3. Select the Performance Management program you want to uninstall.
In Windows **Control Panel**, choose **Programs and Features**[#], and then select the Performance Management program you want to uninstall.
[#]: This name might differ depending on the Windows version.
4. Select **Remove** and click the **OK** button.
The selected program is uninstalled.

Precaution

If user account control functionality (UAC) is enabled on the OS, the User Account Control dialog box might be displayed during uninstallation. If this dialog box is displayed, click the Continue button to continue uninstallation, or click the Cancel button to cancel uninstallation.

2.3 Changing the system configuration of PFM - Agent for Microsoft SQL Server

You might need to change the PFM - Agent for Microsoft SQL Server system configuration because the network configuration or the host name of the monitored system has changed.

When you change the PFM - Agent for Microsoft SQL Server system configuration, you must also change the settings for PFM - Manager and PFM - Web Console. For details about how to change the Performance Management system configuration, see the chapter on installation and setup in the *JPI/Performance Management Planning and Configuration Guide*. When you change the physical host name, PFM - Agent for Microsoft SQL Server requires you to update the `SQL_HOST` item with the new host name by using the `jpccconf inst setup` command. For details about how to change, see 2.4.2 Updating an instance environment.

2.4 Changing the operation of PFM - Agent for Microsoft SQL Server

In some circumstances, such as when changes are made to the way in which collected operation monitoring data is utilized, you might need to change how PFM - Agent for Microsoft SQL Server operates. For example, you might need to change the storage location of performance data or the instance environment.

This section describes how to change the operation of PFM - Agent for Microsoft SQL Server. For details about changing operation across the entire Performance Management system, see the chapter on installation and setup in the *JP1/Performance Management Planning and Configuration Guide*.

2.4.1 Changing the storage location of performance data

The performance data collected by PFM - Agent for Microsoft SQL Server is managed by using the Store database for the Remote Monitor Store service of PFM - Agent for Microsoft SQL Server.

(1) Using the `jpccconf db define` command to change settings

The Store database uses the following folders to manage the collected performance data. These folders can be changed by using the `jpccconf db define` command. If you need the performance data collected before the Store database storage location is changed, execute the `jpccconf db define` command with the `-move` option specified. For details about the `jpccconf db define` command, see the manual JP1/Performance Management Reference.

- Save folder
- Backup folder
- Partial backup destination folder[#]
- Export folder
- Import destination folder[#]

#

This folder can be set only when the Store version is 2.0.

The following table describes the options of the `jpccconf db define` command, including the values that can be specified.

Table 2–11: Settings related to the storage locations of performance data

Description	Option name	Specifiable value (Store 1.0) ^{#1}	Specifiable value (Store 2.0) ^{#1}	Default ^{#2}
The folder in which performance data is stored	<code>sd</code>	Folder name, from 1 to 127 bytes	Folder name, from 1 to 214 bytes	<i>installation-folder\agtq\store\instance-name</i>
The folder to which performance data is backed up	<code>bd</code>	Folder name, from 1 to 127 bytes	Folder name, from 1 to 211 bytes	<i>installation-folder\agtq\store\instance-name\backup</i>
The folder to which performance data is partially backed up	<code>pbd</code>	--	Folder name, from 1 to 214 bytes	<i>installation-folder\agtq\store\instance-name\partial</i>
The maximum number of generations of performance data to be backed up	<code>bs</code>	1 to 9	1 to 9	5

Description	Option name	Specifiable value (Store 1.0)#1	Specifiable value (Store 2.0)#1	Default#2
The folder to which performance data is exported	dd	Folder name, from 1 to 127 bytes	Folder name, from 1 to 127 bytes	<i>installation-folder</i> \agtq\store\ <i>instance-name</i> \dump
The folder to which performance data is imported	id	--	Folder name, from 1 to 222 bytes	<i>installation-folder</i> \agtq\store\ <i>instance-name</i> \import

Legend:

--: This item cannot be set.

#1

You must specify as the folder name either the relative path name from the default storage folder for the Store database (*installation-folder*\agtq\store*instance-name*) or the absolute path name.

#2

For the default save destination for logical host operation, replace *installation-folder* with *environment-folder* \jplpc.

(2) Editing the jpcsto.ini file to change settings (for Store version 1.0 only)

If the Store version is 1.0, you can directly edit the jpcsto.ini file to change the settings of the above items.

(a) Setting items in jpcsto.ini

The following table lists the label names for which information can be edited in the jpcsto.ini file, and other information such as the values that can be specified.

Table 2–12: Performance-data storage location settings (under [Data Section] in jpcsto.ini)

Description	Label name	Specifiable value (Store 1.0)#1	Default#2
The folder in which performance data is stored	Store Dir#3	Folder name, from 1 to 127 bytes	<i>installation-folder</i> \agtq\store\ <i>instance-name</i>
The folder to which performance data is backed up	Backup Dir#3	Folder name, from 1 to 127 bytes	<i>installation-folder</i> \agtq\store\ <i>instance-name</i> \backup
The maximum number of generations of performance data to be backed up	Backup Save	1 to 9	5
The folder to which performance data is exported	Dump Dir#3	Folder name, from 1 to 127 bytes	<i>installation-folder</i> \agtq\store\ <i>instance-name</i> \dump

#1

- The folder name must be an absolute path name or a relative path name from the default Store database folder (*installation-folder*\agtq\store).
- Characters that can be specified are alphanumeric characters, symbols, and spaces, excluding the characters listed below:
; , * ? ' " < > |
- If the specified value is invalid, the Agent Store service cannot start.

#2

For the default save destination for logical host operation, replace *installation-folder* with *environment-folder* \jplpc.

#3

You cannot specify the same folders for Store Dir, Backup Dir, and Dump Dir.

(b) Before editing the jpcsto.ini file

- When changing the Store database folder, make sure that the folder after the change has already been created.
- When the Store database folder is changed, performance data collected before the change can no longer be used. If the performance data collected before the change is needed, carry the data over as follows:
 1. Use the `jpctool db backup` command to back up the performance data stored in the Store database.
 2. Change the Store database folder as described in (c) *Editing the jpcsto.ini file*.
 3. Use the `jpctool db restore` command to restore the backed up data into the new folder.

(c) Editing the jpcsto.ini file

To edit the jpcsto.ini file:

1. Stop the PFM - Agent service.
If PFM - Agent programs and services are active on the local host, stop them all.
2. Use a text editor, for example, to open the jpcsto.ini file.
3. Change the storage destination folder for performance data, for example.
Modify the shaded areas below as needed.

```
      :  
[Data Section]  
  
Store Dir=.  
  
Backup Dir=. \backup  
  
Backup Save=5  
  
Dump Dir=. \dump  
  
      :
```

Important

- Do not insert a space at the beginning of the line or before or after the equal sign (=).
- (.) in each label value indicates the default storage destination folder (*installation-folder*\agtq \store) for the Store database of the Agent Store service. To change the storage destination, specify a relative path from the storage destination folder, or specify an absolute path.
- The `jpcsto.ini` file also describes definition information in addition to the database storage destination folder. Therefore, do not change the values other than those in the [Data Section] section. If you change the values other than those in the [Data Section] section, Performance Management might not operate normally.

4. Save and close the jpcsto.ini file.

5. Start the Performance Management programs and services.

Note:

When you use this procedure to change the Store database folder, the performance data files are not deleted from the previous folder. If these files are no longer necessary, delete only the following files:

- All files with the .DB extension
- All files with the .IDX extension

2.4.2 Updating an instance environment

To update an instance environment, check the name of the instance that you want to update, and change the instance information. Update an instance environment on a PFM - Agent host.

Before you change an information item, check the following table. For details about Microsoft SQL Server instance information, see your Microsoft SQL Server documentation.

Table 2–13: PFM - Agent for Microsoft SQL Server instance information

Item	Description	Specifiable value	Default value
Microsoft SQL Server instance name	This item is not updatable. The current setting is displayed only.	--	--
SQL_HOST	This item is updatable. Microsoft SQL Server host name for a monitoring target. If the Microsoft SQL Server host is a logical host, specify the logical host.	--	Previous value
SQL_USER	This item is updatable. Specifies the user name for Microsoft SQL Server authentication. (A character string of 128 or fewer bytes.)	--	Previous value
SQL_PASSWORD	This item is updatable. Specifies the password of the Microsoft SQL Server user used for Microsoft SQL Server authentication.	--	Previous value
SQL_ERRORLOG	This item is updatable. Specify the absolute path of the error log file for the monitored Microsoft SQL Server instance, by using single-byte characters. Even when the file name or path includes single-byte space characters, do not surround it with quotation marks (").	A character string of 512 or fewer bytes that does not include the following characters: <ul style="list-style-type: none"> • Tabs • The following symbols: / , ; * ? " < > 	Previous value
STARTUP_PENDING	This item is updatable. Specify the pending time from when PFM - Agent for Microsoft SQL Server starts until it transfers to normal processing.	0 to 3,600 (seconds) Pending is not performed when 0 is specified.	Previous value
LOG_PATH	This item is updatable. Specifies the full path name of the folder for storing agent log information.	A character string of 245 or fewer bytes that does not include the following characters:	Previous value

Item	Description	Specifiable value	Default value
LOG_PATH	If you specify a path containing space characters, do not enclose the path in quotation marks (").	<ul style="list-style-type: none"> • Tabs • The following symbols: / , ; * ? " < > 	Previous value
LOG_SIZE	This item is updatable. Specifies the maximum size of one agent log file.	1 to 32 (megabytes). The minimum recommended value is 16.	Previous value
TIMEOUT	This item is updatable. Specifies the query timeout value for database access.	1 to 3,600 (seconds)	Previous value
LOGIN_TIMEOUT	This item is updatable. Specifies the access timeout value for database access. The value is in seconds.	1 to 3,600 (seconds)	Previous value
DB_FREE_PERC_OPTION	This item is updatable. Specify how to display the values of the fields related to the percentage of free space in the PD_DS record (the Free % field and the Data Unallocate % field) when the value is negative.	{ Y N } If Y is specified, the value specified for DB_FREE_PERC_NUMBER is displayed. If N is specified, the value of the Free % field and the Data Unallocate % field is displayed as it is when its value is negative.	Previous value
DB_FREE_PERC_NUMBER	This item is updatable. Specify the values of the fields related to the percentage of free space in the PD_DS record (the Free % and the Data Unallocate % field) when its value is negative. The replacement is enabled only when the value of DB_FREE_PERC_OPTION is Y.	-1 to 999	Previous value
LIMIT_PD_LD_NUMBER	This item is updatable. Specify the maximum number of collection records for the PD_LD record.	0 to 900,000 If you specify 0, no upper limit is set, and all data is collected.	Previous value
LIMIT_PD_EE_NUMBER	This item is updatable. Specify the maximum number of collection records for the PD_EE record. This item takes effect when log data is collected and when monitoring is performed by using alarms. Specify the maximum number of occurrences that can be collected during the collection interval set for Collection Interval. For detail about PD_EE record, see <i>Errorlog Error Detail (PD_EE)</i> of 5. <i>Records</i> . Note: For real-time reports, this item does not take effect, and all error records output to the Microsoft SQL Server error log are collected.	100 to 100,000	Previous value

Legend:

--: No limit

Use the `jpccconf inst list` command to check the instance name. To update an instance environment, use the `jpccconf inst setup` command. For details about the command, see the chapter on the commands in the manual *JPI/Performance Management Reference*.

Updating an instance environment involves the steps described below. To update multiple instance environments, repeat the procedure for each instance environment.

1. Check the instance name.

Execute the `jpccconf inst list` command specified with the service key that indicates PFM - Agent for Microsoft SQL Server.

For example, when you check the instance name of the PFM - Agent for Microsoft SQL Server, execute the following command:

```
jpccconf inst list -key SQL
```

For example, if the instance name is SQL1, the command displays SQL1.

2. Stop all the PFM - Agent for Microsoft SQL services.

If the service is still active in the instance environment that is to be updated when you execute the `jpccconf inst setup` command, a confirmation message is displayed to enable you to stop the service. If you stop the service, update processing resumes; if you do not stop the service, update processing is canceled.

3. Execute the `jpccconf inst setup` command specified with the service key that indicates PFM - Agent for Microsoft SQL Server and the instance name.

For example, if you are updating the instance environment for the PFM - Agent for Microsoft SQL Server with instance name SQL1, execute the following command:

```
jpccconf inst setup -key SQL -inst SQL1
```

4. Update the instance information for Microsoft SQL Server.

Enter the information shown in [Table 2-13](#) in accordance with the command's instructions. The current settings are displayed. To use the displayed value, press the Enter key. When you have finished entering information, the instance environment is updated.

5. Restart the services in the updated instance environment.

For details about starting services, see the chapter on starting and stopping Performance Management in the *JPI/Performance Management User's Guide*.

Note:

If you want to change an item that cannot be updated, delete the instance environment and then re-create it.

For details about commands, see the chapter on commands in the manual *JPI/Performance Management Reference*.

2.4.3 Updating the Store version to 2.0

The Store database comes in two versions, 1.0 and 2.0. For details about Store version 2.0, see the chapter that describes the design of the operations monitoring system in the *JPI/Performance Management Planning and Configuration Guide*.

Store version 2.0 is provided as the default when you perform a new installation of PFM - Agent for Microsoft SQL Server version 08-11 or later in an environment with PFM - Base or PFM - Manager version 08-11 or later. In other

cases, the Store version remains 1.0. If you want to use Store 2.0, you must use a setup command to update the version to 2.0.

If you have to restore Store 1.0 from Store 2.0, perform `unsetup` of Store 2.0.

The following table describes the installation conditions, whether Store 2.0 is available for the given conditions, and the procedure for enabling Store 2.0.

Table 2–14: Availability of Store 2.0 and the procedure for enabling it

Installation conditions		Whether Store 2.0 is available	Procedure for enabling Store 2.0
Version of installed PFM - Base or PFM - Manager	PFM - Agent installation type		
08-00 or earlier	Overwrite installation	Not supported	Upgrade PFM - Base or PFM - Manager to version 08-11 and then execute the setup command.
	New installation		
08-11 or later	Overwrite installation	An existing instance is supported after setup	Execute the setup command.
		A new instance is supported	Use the <code>jppeconf inst setup</code> command to set up when the instance is configured.
	New installation	Supported	Use the <code>jppeconf inst setup</code> command to set up when the instance is configured.

(1) Setup of Store 2.0

This subsection describes how to set up Store version 2.0 when you update the Store database.

1. Estimate the system resources and determine the retention period.

Check whether the system resources that Store 2.0 requires are suitable for the execution environment. The system resources to be considered are the following:

- Disk capacity
- Number of files
- Number of files opened by one process

These can be adjusted by the retention period settings. When you specify the retention period, take into account the resources available in the execution environment. See the Release Notes for details about estimating system resources.

2. Review the folder settings.

When the Store version is updated to 2.0, the Agent Store service might fail to start with the same folder settings that were available in Store 1.0. For this reason, you must review the settings of the folders used by the Agent Store service. You can use the `jppeconf db define` command to view and change the settings of these folders.

The maximum length of the names of the save destination folder, backup destination folder, and other folders used by the Store database in Store 2.0 differs from the maximum length in Store 1.0. In particular, be careful when the folder settings have been changed to use a relative path name in Store 1.0. If the settings have been changed, confirm that the length of the absolute path name for the relative path name is no more than 214 bytes, which is the maximum length for folder names in Store 2.0. If the absolute path name is longer than the maximum, change the settings of each folder used by the Agent Store service before proceeding to the next step.

3. Execute the setup command.

Execute the following command to update the Store version to 2.0:

```
jpccconf db vrset -ver 2.0
```

To update the Store version to 2.0, execute the `jpccconf db vrset -ver 2.0` command. You must execute this command for each Agent instance. For details about the `jpccconf db vrset` command, see the manual *JPI/Performance Management Reference*.

4. Set the retention period.

Specify the retention period that you determined in step 1. Start the Agent Store service, and then specify the retention period in PFM - Web Console.

(2) Unsetup of Store 2.0

Use the `jpccconf db vrset -ver 1.0` command to perform unsetup of Store 2.0. When unsetup is performed, the entire Store database is initialized and the Store version reverts to 1.0.

For details about the `jpccconf db vrset` command, see the manual *JPI/Performance Management Reference*.

(3) Notes

This subsection provides notes about updating.

(a) When migrating from Store version 1.0 to Store version 2.0

When the Store database is migrated from Store version 1.0 to Store version 2.0, retention period settings for records of the PI record type are carried over. For records of the PD record type, however, the default number of retention days is set for each record regardless of the previously set value (number of retained records), and data collected before the number of retention days is deleted.

For example, in Store version 1.0, when the number of retained records is set to 1,000 for PD records for which Collection Interval is set to 3,600 seconds, 24 PD records are retained in a day. As a result, data for $1,000 / 24$ (roughly 42) days is retained. After this Store database has been migrated to Store version 2.0, if the default number of retention days is set to 10, data from 11 or more days before is deleted and can no longer be viewed.

Before migrating to Store version 2.0, check the settings for the number of retained records for records of the PD record type. If data is set to be retained for the default number of retention days or more for Store version 2.0, use the `jpctool db dump` command to output the data in the database. See the Release Notes for details about the default number of days saved in Store version 2.0.

(b) When returning from Store version 2.0 to Store version 1.0

When unsetup is performed for Store version 2.0, data is initialized. Therefore, before changing to Store version 1.0, use the `jpctool db dump` command to output Store version 2.0 information.

2.5 Starting the command prompt

When OS user account control functionality (UAC) is enabled, the command prompt can run under the following two permissions modes:

- Administrator permissions mode (administrator console)
This command prompt can perform all Windows operations.
- Standard permissions mode (standard console)
This command prompt can perform operations possible with user permissions.

If user account control functionality (UAC) is disabled, the administrator console is always started.

Make sure that commands provided by Performance Management are executed in the administrator console.

The following table describes how to start the command prompt for each administrator user.

Table 2–15: How to start the command prompt for each administrator user

Administrator group	Administrator user	Start method
Administrators	Administrator	When the command prompt is started, the administrator console is also started.
	Any user other than the above	<p>When UAC is enabled</p> <ul style="list-style-type: none">• When the command prompt is started, the standard console is also started.• When the administrator console is started, the User Account Control dialog box is displayed. Click the Continue button in this dialog box to start the administrator console. If the Cancel button is clicked, the command prompt does not start. <p>When UAC is disabled</p> <ul style="list-style-type: none">• When the command prompt is started, the administrator console is also started.

There are two kinds of administrator console: the one provided by the OS, and the one provided by PFM - Base. The following explains how to start each of them.

2.5.1 Starting the administrator console provided by the OS

From the Start menu, choose Programs, and then Accessories, and then right-click Command prompt. Then choose Run as administrator.

Whether the started command prompt is an administrator console can be determined by whether Administrator is displayed in the title bar.

2.5.2 Starting the administrator console provided by PFM - Base

From the Start menu, choose Programs, then Performance Management, and then Administrator console.

2.6 Failover in the mirroring configuration

This section explains how PFM - Agent for Microsoft SQL Server monitors the databases in the mirroring configuration and how PFM - Agent for Microsoft SQL Server operates when the failover occurs in the databases in the mirroring configuration.

2.6.1 Monitoring databases in the mirroring configuration

When PFM - Agent for Microsoft SQL Server monitors the databases in the mirroring configuration, PFM - Agent for Microsoft SQL Server collects the performance information from the databases other than the mirror databases (such as the principal database and the database(s) in the non-mirroring configuration).

The following figure summarizes how PFM - Agent for Microsoft SQL Server monitors the database in the mirroring configuration:

Figure 2–5: Overview of how PFM - Agent for Microsoft SQL Server monitors the database in the mirroring configuration

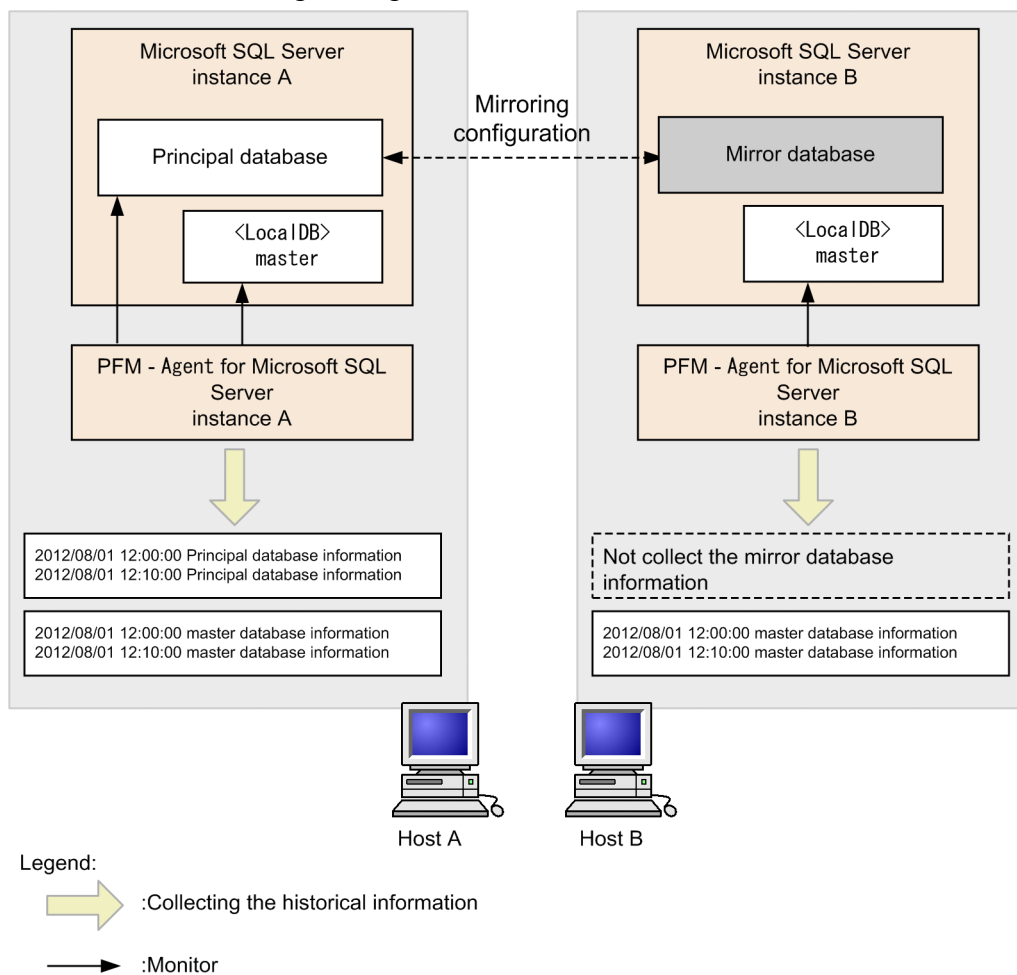

In addition, install the PFM - Agent for Microsoft SQL Server in each system when you build the mirroring configuration.

2.6.2 Monitoring while a failover occurs in databases in the mirroring configuration

The following figure summarizes how PFM - Agent for Microsoft SQL Server monitors the databases in the mirroring configuration while a failover occurs in those databases:

Figure 2–6: Overview of how PFM - Agent for Microsoft SQL Server monitors the database in the mirroring configuration while a failover occurs.

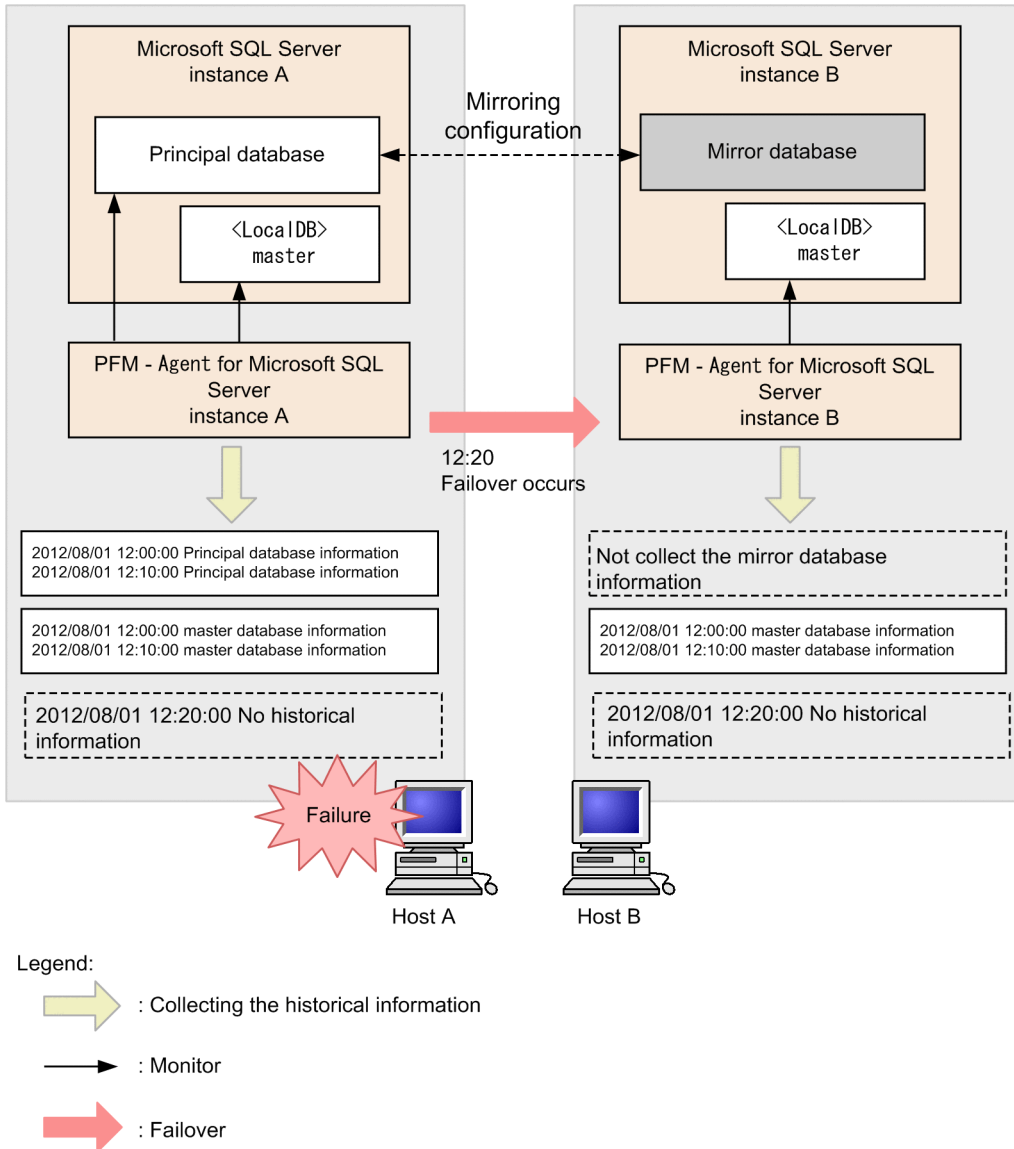

If a failover occurs in the databases in the mirroring configuration when PFM - Agent for Microsoft SQL Server is collecting the performance information from the Microsoft SQL Server instance, PFM - Agent for Microsoft SQL Server does not collect performance information from those instances just when the failover is occurring.

In this case, although "KAVF21812-E" message is output to the agent log, PFM - Agent for Microsoft SQL Server operates properly.

2.6.3 Monitoring after a failover occurs in databases in the mirroring configuration

The following figure summarizes how PFM - Agent for Microsoft SQL Server monitors the databases in the mirroring configuration after a failover occurs in those databases.

Figure 2–7: Monitoring after a failover occurs in databases in the mirroring configuration

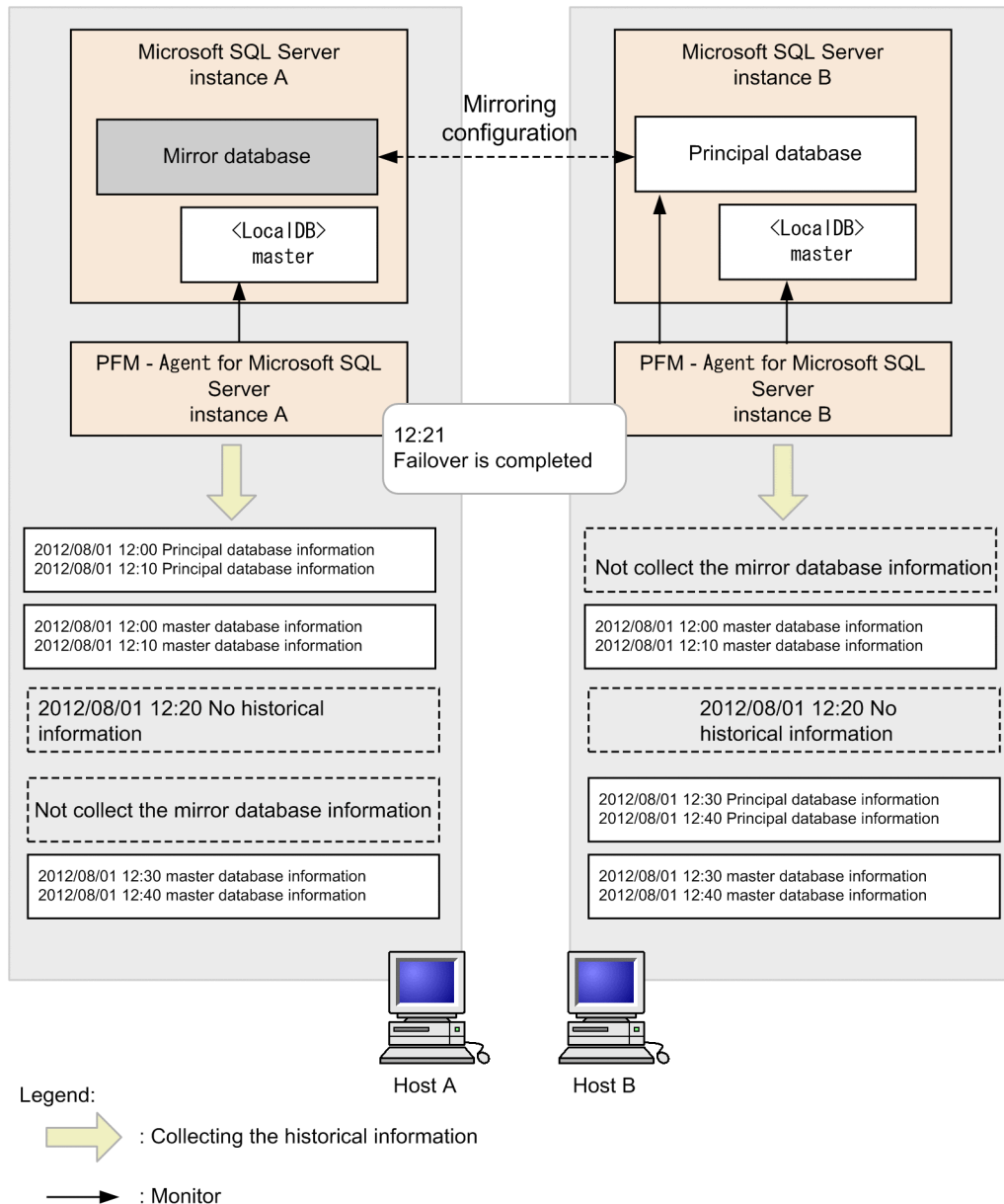

After a failover completes, the former mirror database on the host B moves online as the new principal database and the former principal database takes on the role of the mirror database.

After the failover completes, the instance of the PFM - Agent for Microsoft SQL Server which monitors the databases turned into the mirror databases (the instance A of the PFM - Agent for Microsoft SQL Server on the figure 2-6) collects the performance information from the databases other than the mirror databases.

Moreover, the instance of the PFM - Agent for Microsoft SQL Server which monitors the databases turned into the principal database (the instance B of the PFM - Agent for Microsoft SQL Server on the figure 2-6) collects the performance information from the principal databases and the databases in non-mirroring configuration.

2.7 Monitoring in the SQL Server AlwaysOn Availability Group configuration

PFM - Agent for Microsoft SQL Server collects information about the databases (primary database and secondary database) configured by using the SQL Server AlwaysOn Availability Group functionality. For the secondary database, information is collected only when all connections to it are permitted.

The following figure shows an example of the SQL Server AlwaysOn Availability Group configuration when not all of the connections to the secondary database are permitted.

Figure 2–8: Example of monitoring in the SQL Server AlwaysOn Availability Group configuration

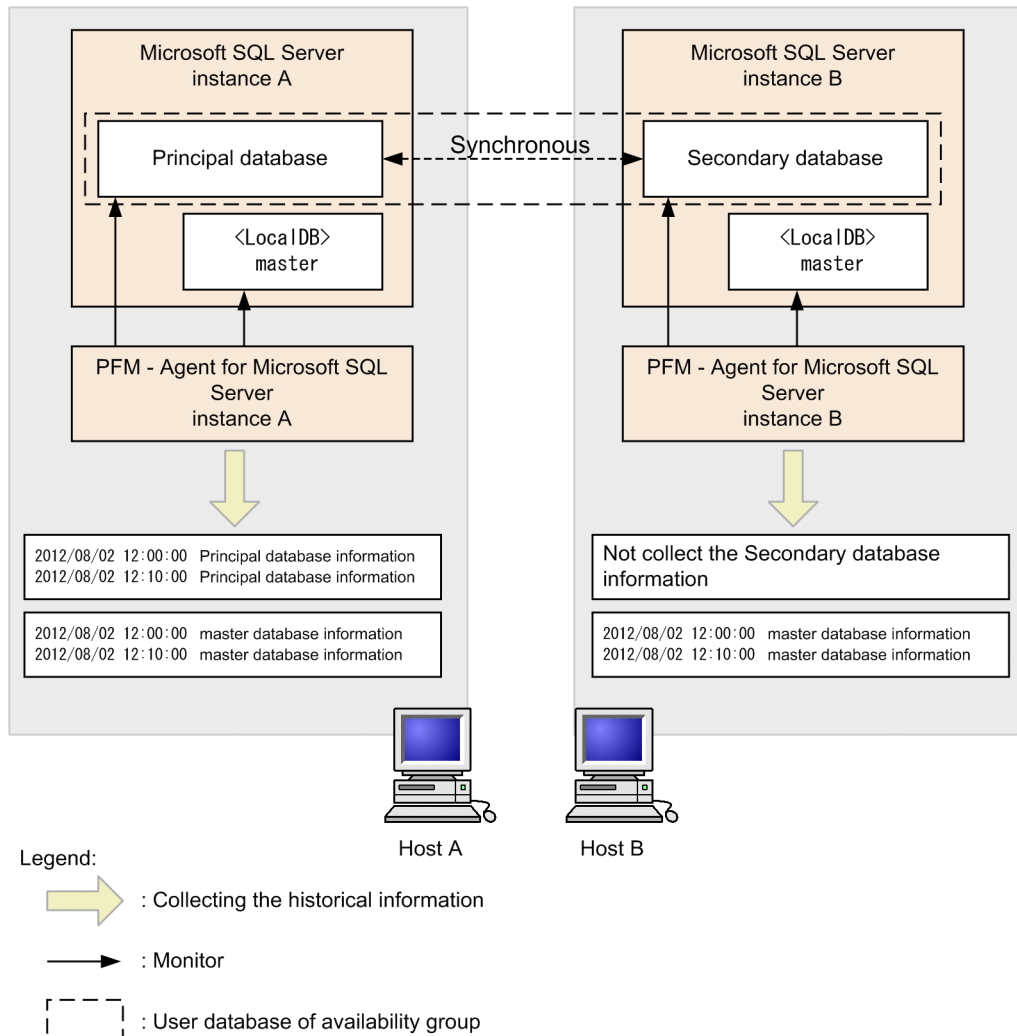

For details about operation during or after failover of the primary database and secondary database, see [2.6 Failover in the mirroring configuration](#).

2.7.1 Monitoring during failover in the SQL Server AlwaysOn Availability Group configuration

When PFM - Agent for Microsoft SQL Server collects information for the instances of the Microsoft SQL Server that has databases in the SQL Server AlwaysOn Availability Group configuration, if a failover occurs, PFM - Agent for Microsoft SQL Server does not collect information (at the time the failover occurs) for the instances of each database.

Also, the KAVF219812-E message is output to the agent log. However, there are no operational problems.

2.7.2 Monitoring after failover in the SQL Server AlwaysOn Availability Group configuration

After failover is complete, the primary database switches to host B, and the secondary database switches to host A.

After the failover, the PFM - Agent for Microsoft SQL Server instance with the database that has switched to the secondary database collects the information for databases other than the secondary database. However, if all connections to the secondary database are permitted, the information for the secondary database can be also collected.

Also, the PFM - Agent for Microsoft SQL Server instance with the database that switched to the primary database collects the information for the primary database and the databases that are not in the SQL Server AlwaysOn Availability Group configuration.

2.8 Backup and restoration

This section explains how to back up and restore PFM - Agent for Microsoft SQL Server.

In preparation for the system failure due to errors, back up the configuration files. When you change the system configuration (such as setting up PFM - Agent for Microsoft SQL Server), back up the configuration files.

For details about how to back up and restore the whole Performance Management system, see the chapter on backup and restoration in the *JPI/Performance Management User's Guide*.

2.8.1 Backup

When you back up the configuration files, you back up those files in any measure (such as copying the files). When you back up those configuration files, make sure that the PFM - Agent for Microsoft SQL Server service is inactive before you back up the files.

Important

When you back up the configuration files, record the product version number of PFM - Agent for Microsoft SQL Server. For details about the product version number, see the *Release Notes*.

The following table lists the settings files for PFM - Agent for Microsoft SQL Server that must be included in a backup.

For details about other files, see the section presenting a list of files to be backed up for PFM - Agent (in Windows) in the *JPI/Performance Management User's Guide*.

Table 2–16: Backup target files for PFM - Agent for Microsoft SQL Server (for a physical host)

File name	Description
<i>installation-folder</i> \agtq\agent*.ini files	Configuration files for Agent Collector service
<i>installation-folder</i> \agtq\agent\ <i>instance-name</i> *.ini files	
<i>installation-folder</i> \agtq\store*.ini files	Configuration files for Agent Store service
<i>installation-folder</i> \agtq\store\ <i>instance-name</i> *.ini files	

Table 2–17: Backup target files for PFM - Agent for Microsoft SQL Server (for a logical host)

File name	Description
<i>installation-folder</i> \agtq\agent*.ini files	Configuration files for Agent Collector service
<i>Environment-folder</i> [#] \jplpc\agtq\agent\ <i>instance-name</i> *.ini files	
<i>installation-folder</i> \agtq\store*.ini files	Configuration files for Agent Store service
<i>Environment-folder</i> [#] \jplpc\agtq\store\ <i>instance-name</i> *.ini files	

Environment-folder is the folder that is created on the shared disk when setting up the logical host.

2.8.2 Restoration

Make sure that you meet the following prerequisite conditions before you restore the backup files to the storage locations of those configuration files. Copy the backup files and overwrite the existing configuration files on PFM - Agent host.

Prerequisites:

- Already install PFM - Agent for Microsoft SQL Server
- PFM - Agent for Microsoft SQL Server service is inactive.



Important

When you restore the configuration files for PFM - Agent for Microsoft SQL Server, the product version number of the PFM - Agent for Microsoft SQL Server on the backup environment is the same as that of the PFM - Agent for Microsoft SQL Server on the restoration target environment. For details about the product version number, see the *Release Notes*.

2.9 Online manuals

The standard manual medium accompanying the Performance Management program product contains a manual that you can copy to the host on which PFM - Web Console is installed and then view in a Web browser. Make sure that you copy the manual to the executing and standby nodes when PFM - Web Console runs in a cluster system.

2.9.1 Setting procedures

The following describes setting procedures required when you view the manual from the help menu bar of PFM - Web Console and when you view the manual on the hard disk of the machine being used.

(1) See the manual from the help menu bar of PFM - Web Console

The following describes the setting procedure required when you view the manual from the help menu bar of PFM - Web Console.

1. Register PFM - Agent with PFM - Web Console, following the PFM - Web Console setup procedure (Follow the procedure to register an additional PFM - Agent).
2. On the host on which PFM - Web Console is installed, create a directory to copy the manual to.
 - Windows: *Web-Console-installation-folder\doc\language-cord\help-ID-of-PFM - Agent-for-Microsoft-SQL-Server*
 - UNIX: */opt/jp1pcwebcon/doc/language-cord/help-ID-of-PFM - Agent-for-Microsoft-SQL-Server*

For the help ID, see *B. List of Identifiers*.

3. From the manual supplied medium, copy all the manual files to the root of the directory you created.

HTML manual:

Windows: all the html files and FIGURE folder from the *applicable-drive\MAN\3021\material-number* (such as 03004A0D)

UNIX: all the html files and FIGURE folder from */mount-point-directory-for-the-supplied-medium/MAN/3021/material-number* (such as 03004A0D)

PDF manual:

Windows: all the PDF files from the *applicable-drive\MAN\3021\material-number* (such as 03004A0D)

UNIX: all the PDF files from */mount-point-directory-for-the-supplied-medium/MAN/3021/material-number* (such as 03004A0D)

Make sure that you copy the index.htm files (for the HTML manual) or the PDF files (for the PDF manual) to the root of the created directory.

4. Restart PFM - Web Console.

(2) See the manual from the hard disk

Execute the setup.exe command on supplied medium to install the manual, or copy htm files, PDF files, and GIF files to any folders or directories. For HTML manual, the folder or directory organization must be:

```
html (storage folder or directory of the htm files and the PDF files)
└─ FIGURE (storage folder or directory of GIF files)
```

2.9.2 Viewing the manual

To view the manual:

1. In the menu bar of the PFM - Web Console main window, click Help. A help selection window appears.
2. Click the manual name, or click [PDF] after the manual name.
Clicking the manual name displays the manual in HTML format. Clicking [PDF] displays the manual in PDF format.

Notes about displaying manuals in a Web browser

In Windows, if you display an online manual from the **Start** menu, the HTML manual may be displayed in the Web browser that is already open.

3

Operating PFM - Agent for Microsoft SQL Server in a Cluster System

This chapter describes the procedures for installing and setting up PFM - Agent for Microsoft SQL Server for use in a cluster system. This chapter also describes the flow of processing when you use PFM - Agent for Microsoft SQL Server in a cluster system.

3.1 Cluster system overview

A *cluster system* is a system in which multiple server systems are linked and operated as a single system. The Microsoft SQL Server Database that is a monitoring target program of PFM - Agent for Microsoft SQL Server can operate in the following cluster systems:

- An HA (High Availability) cluster system configured for Microsoft SQL Server
- A Federated database server configured for Microsoft SQL Server

This section describes the configuration you use for operating PFM - Agent for Microsoft SQL Server in a cluster system. For an overview of cluster systems and information about the system configuration when you use a Performance Management system in a cluster system, see the chapter on operation in a cluster system in the *JPI/Performance Management User's Guide*.

The term *cluster system* when used alone in this chapter refers to an HA cluster system.

3.1.1 HA cluster system

(1) The system configuration of PFM - Agent for Microsoft SQL Server monitoring Microsoft SQL Server Database in an HA cluster system

You can improve availability of an Microsoft SQL Server Database by using it in an HA cluster system, which can perform a failover if a failure occurs.

Typically, when you operate Microsoft SQL Server in an HA cluster system, you construct an environment that permits execution of the same Microsoft SQL Server instance on both an executing node and a standby node. The configuration you use stores a single set of Microsoft SQL Server data (data files, configuration files, log files, etc.) on a shared disk.

There are also cases when the configuration or method of operating Microsoft SQL Server in a cluster system depends on the system.

(2) PFM - Agent for Microsoft SQL Server configuration in an HA cluster system

PFM - Agent for Microsoft SQL Server can operate in an HA cluster system and can monitor Microsoft SQL Server in a cluster configuration. Figure 3-1 shows a configuration for operating PFM - Agent for Microsoft SQL Server in an HA cluster system.

Figure 3–1: Example of an PFM - Agent for Microsoft SQL Server configuration in an HA cluster system

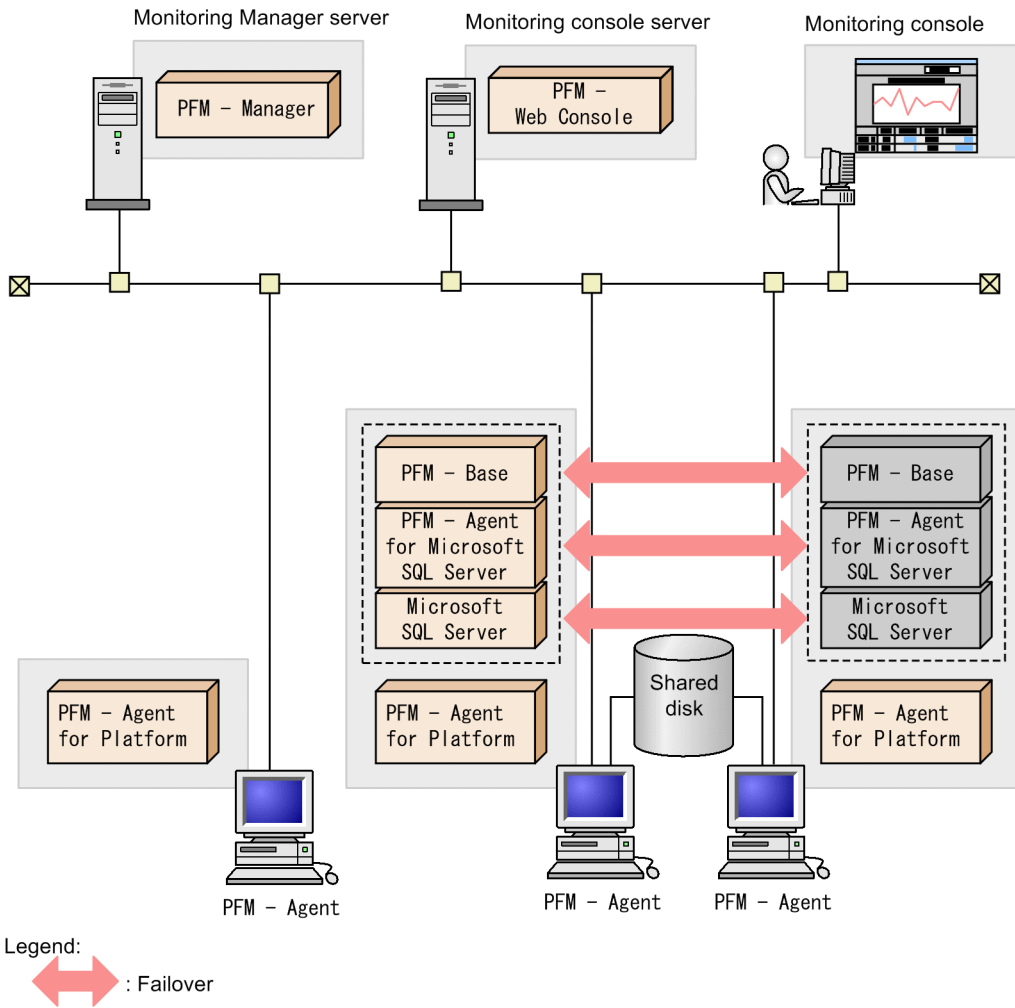

As Figure 3-1 shows, PFM - Agent for Microsoft SQL Server operates in a cluster system and monitors Microsoft SQL Server.

When a failure occurs, failover applies to PFM - Agent for Microsoft SQL Server at the same time it applies to Microsoft SQL Server, allowing PFM - Agent for Microsoft SQL Server to continue monitoring Microsoft SQL Server.

PFM - Agent for Microsoft SQL Server also stores definition information about the shared disk and continues operating when a failover occurs. When there are multiple Performance Management programs on a single logical host, all programs use the same shared directories.

When you monitor multiple Microsoft SQL Servers, you can install PFM - Agent for Microsoft SQL Server on separate logical hosts so that each PFM - Agent for Microsoft SQL Server can operate and perform a failover independently.

3.1.2 Federated database server

(1) The system configuration of PFM - Agent for Microsoft SQL Server monitoring Microsoft SQL Server in a Federated database configuration

Federated database servers are cooperative group of databases which are joined together by horizontally partitioning the table across the nodes and thus creating a distributed partitioned view. Use this federated database server configuration when you make the group of the nodes cooperate so that you can process the data for a large Web site or a large company

Figure 3-2 shows a configuration for operating PFM - Agent for Microsoft SQL Server in a federated database configuration:

Figure 3–2: Example of an PFM - Agent for Microsoft SQL Server configuration in a federated database configuration

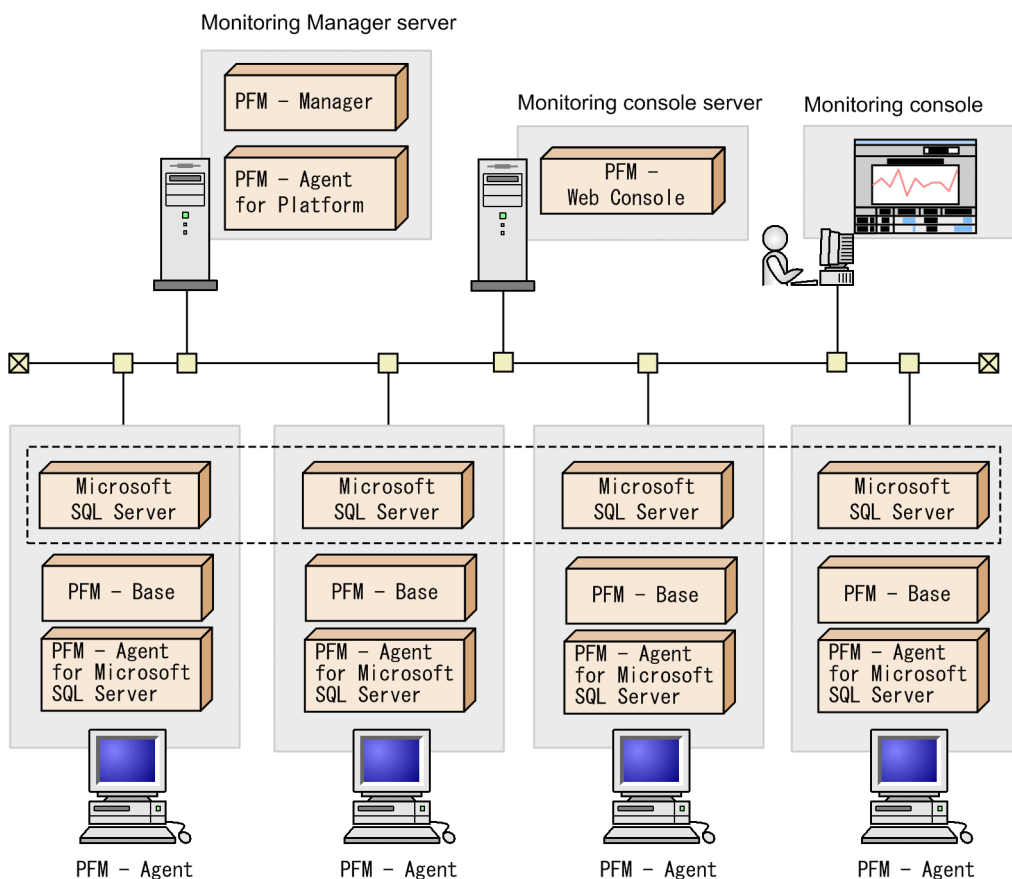

An Microsoft SQL Server system with a unique instance name is run on each node. PFM - Agent for Microsoft SQL Server monitors the Microsoft SQL Server instance on each node.

As with a single-node system, set up PFM - Agent for Microsoft SQL Server and configure it to monitor each node's Microsoft SQL Server Real Application Clusters instance.

Do not register PFM - Agent for Microsoft SQL Server in the cluster software.

Note:

To operate PFM - Agent for Microsoft SQL Server in a federated database server and monitor the federated database server, handle PFM - Agent for Microsoft SQL Server as you would in a system with many single nodes. That is, handle it the same way as in a normal non-cluster system.

3.2 Processing during failover

When a failure occurs on the executing host, processing moves to the standby host.

This section describes failover processing in the event of a failure in PFM - Agent for Microsoft SQL Server. This section also describes how a failure of PFM - Manager affects PFM - Agent for Microsoft SQL Server.

3.2.1 Failover when a failure occurs on a PFM - Agent host

(1) Overview of processing when failover occurs

The following figure shows the processing when failover occurs on a host that is running PFM - Agent for Microsoft SQL Server.

Figure 3–3: Processing when failover occurs on the PFM - Agent host

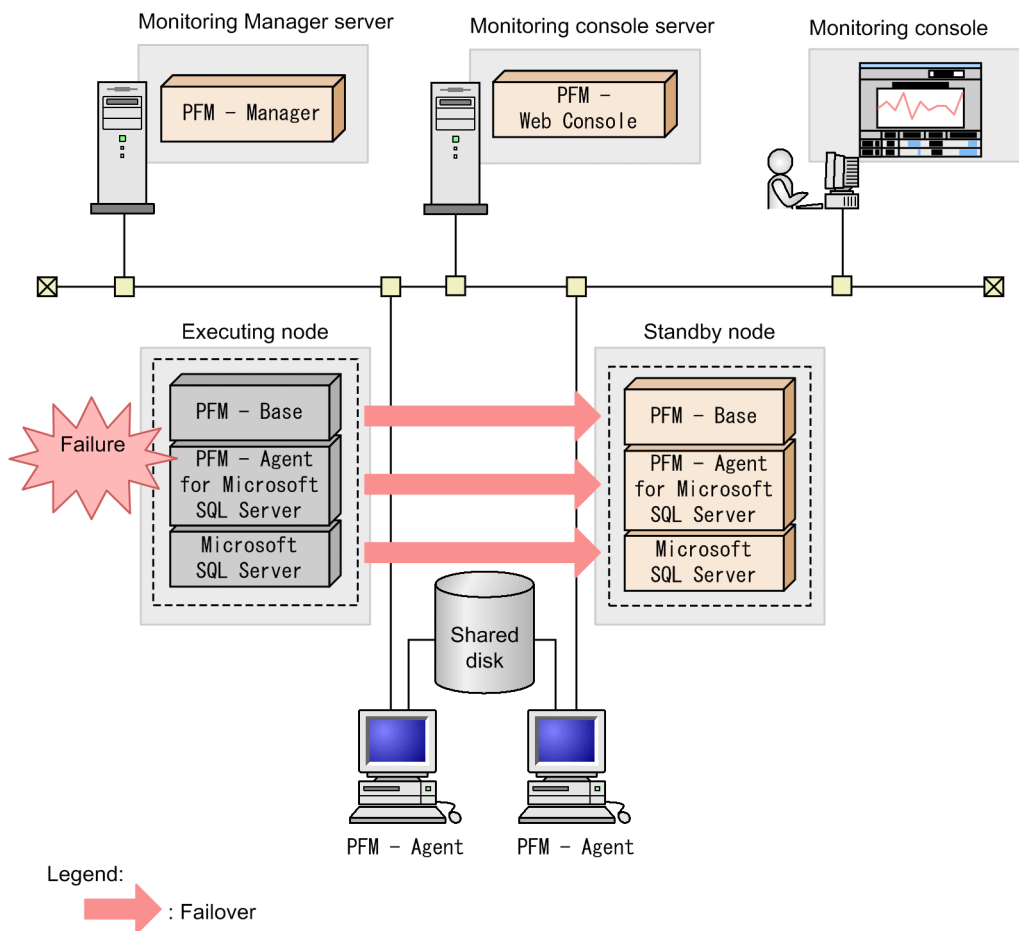

If PFM - Web Console is used while PFM - Agent for Microsoft SQL Server is engaged in failover processing, the message There was no answer(-6) is displayed. When this message is displayed, wait until the failover processing is completed.

After PFM - Agent for Microsoft SQL Server has failed over, an attempt to use PFM - Web Console connects you to the PFM - Agent for Microsoft SQL Server that has started at the target node.

(2) Pending function during failover

(a) About pending function

The pending function delays processing the connection to Microsoft SQL Server for a fixed time period after PFM - Agent for Microsoft SQL Server starts.

Microsoft SQL Server recovery process on standby node can cause delay in connecting to PFM - Agent for Microsoft SQL Server databases. When pending function is used for failover, the PFM - Agent for Microsoft SQL Server connects to Microsoft SQL Server after transaction recovery process completes on the standby node.

The following figure shows the process flow when using the pending function:

Figure 3–4: Processing flow when the pending function is used

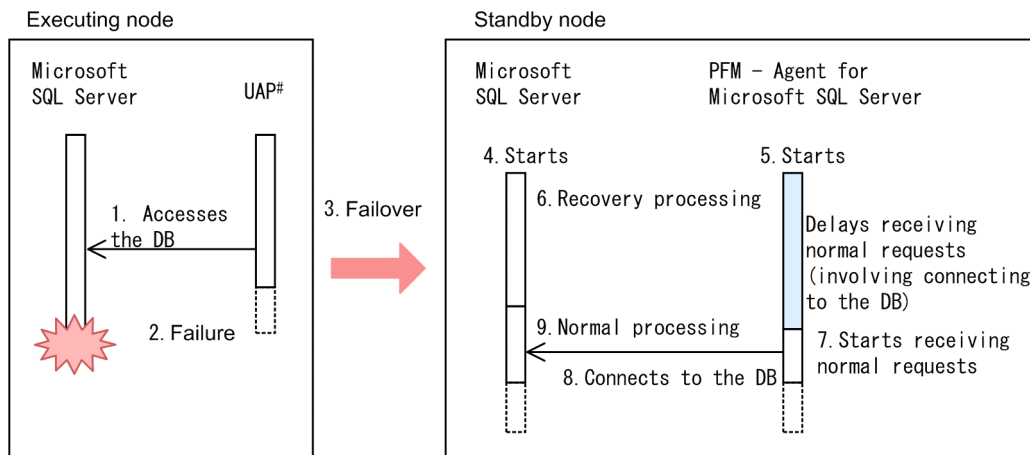

Uses ODBC, ADO, NET library, or others to access Microsoft SQL Server

(b) Specify the pending time

To specify the pending time, you can use the following ways:

- Set up the instance environment settings using the `jpcconf inst setup` command.
- Use PFM - Web Console to change the `STARTUP_PENDING` property of Agent Configuration.

Specify a value in the range from 0 to 3600 (units: seconds). If you specify 0, pending is not performed. Values outside the valid range are ignored.

When failover occurs, the time needed for recovery processing on Microsoft SQL Server differs depending on the server configuration and the processing contents of the application accessing Microsoft SQL Server. Set a pending time longer than the time needed in the actual operating environment.

For information about using the `jpcinssetup` command to set the pending time, see [2.1.4\(2\) Setting up an instance environment](#).

(c) Precautions regarding use of the pending function

- During pending, an attempt to connect or work with PFM - Agent for Microsoft SQL Server through PFM - Web Console will result in an error.
- When you use the `jpc tool service list` command during pending, do not set the status management function to disable, because the `jpc tool service list` command will not return the status until the pending process completes.

- During pending, terminate PFM - Agent for Microsoft SQL Server from the cluster software in a cluster configuration, or from the Windows Start menu, Administrative Tools, and then Services in a non-cluster configuration. Note that regardless of whether a cluster configuration is used, executing the jpscsm stop command for a pending PFM - Agent for Microsoft SQL Server will result in an error.
- If you change the pending value through PFM - Web Console while PFM - Agent for Microsoft SQL Server is running, your change will be applied to the operation after the next start.
- When PFM - Agent for Microsoft SQL Server is pending, the jpectool service list command displays Starting as the status.

3.2.2 Effects when PFM - Manager stops

PFM - Manager affects the entire Performance Management system when it stops.

PFM - Manager centrally manages the agent information of the PFM - Agent for Microsoft SQL Server agents that are running on all nodes. It also controls notification of alarm events in the event a threshold value is exceeded during performance monitoring by PFM - Agent for Microsoft SQL Server as well as execution of actions based on alarm events. Accordingly, when PFM - Manager stops, the entire Performance Management system is affected, as described in Table 3-1.

Table 3–1: Effect on PFM - Agent for Microsoft SQL Server when PFM - Manager stops

Program name	Effects	Solution
PFM - Agent for Microsoft SQL Server	<p>If PFM - Manager stops while PFM - Agent for Microsoft SQL Server is running, PFM - Agent for Microsoft SQL Server:</p> <ul style="list-style-type: none"> • Continues collecting performance data. • Retains alarm events for each alarm definition and retries until PFM - Manager is recovered if it cannot send the alarm events to PFM - Manager. When the number of retained alarm events exceeds 3, the oldest alarm event is overwritten. If PFM - Agent for Microsoft SQL Server is stopped, all the alarm events that have been retained are deleted. • Resets, when PFM - Manager is restarted, the alarm statuses that have already been reported to PFM - Manager. The alarm statuses are then initialized after checking with PFM - Agent for Microsoft SQL Server. • Takes a long time to stop if you attempt to stop it, because PFM - Manager cannot be notified. 	<p>Start PFM - Manager. You can continue to run any PFM - Agent for Microsoft SQL Server that is currently running. Check the common log after PFM - Manager is recovered because alarms may not be reported exactly as expected. (KAVE00024-I)</p>

Consider the effects of stopping PFM - Manager when considering how to operate Performance Management. There are times when you have to stop PFM - Manager in order to change the configuration or perform maintenance work. Hitachi recommends that you schedule maintenance work for times that will have the least impact on operations.

3.3 Installation and setup

This section describes how to install and set up PFM - Agent for Microsoft SQL Server in a cluster system.

For details about how to install and set up PFM - Manager, see the chapters on setup and operation in a cluster system in the *JP1/Performance Management User's Guide*.

3.3.1 Flow for installation and setup

The following figure shows the flow of installing and setting up PFM - Agent for Microsoft SQL Server for logical host use in a cluster system.

Figure 3–5: Flow of installing and setting up PFM - Agent for Microsoft SQL Server in a cluster system

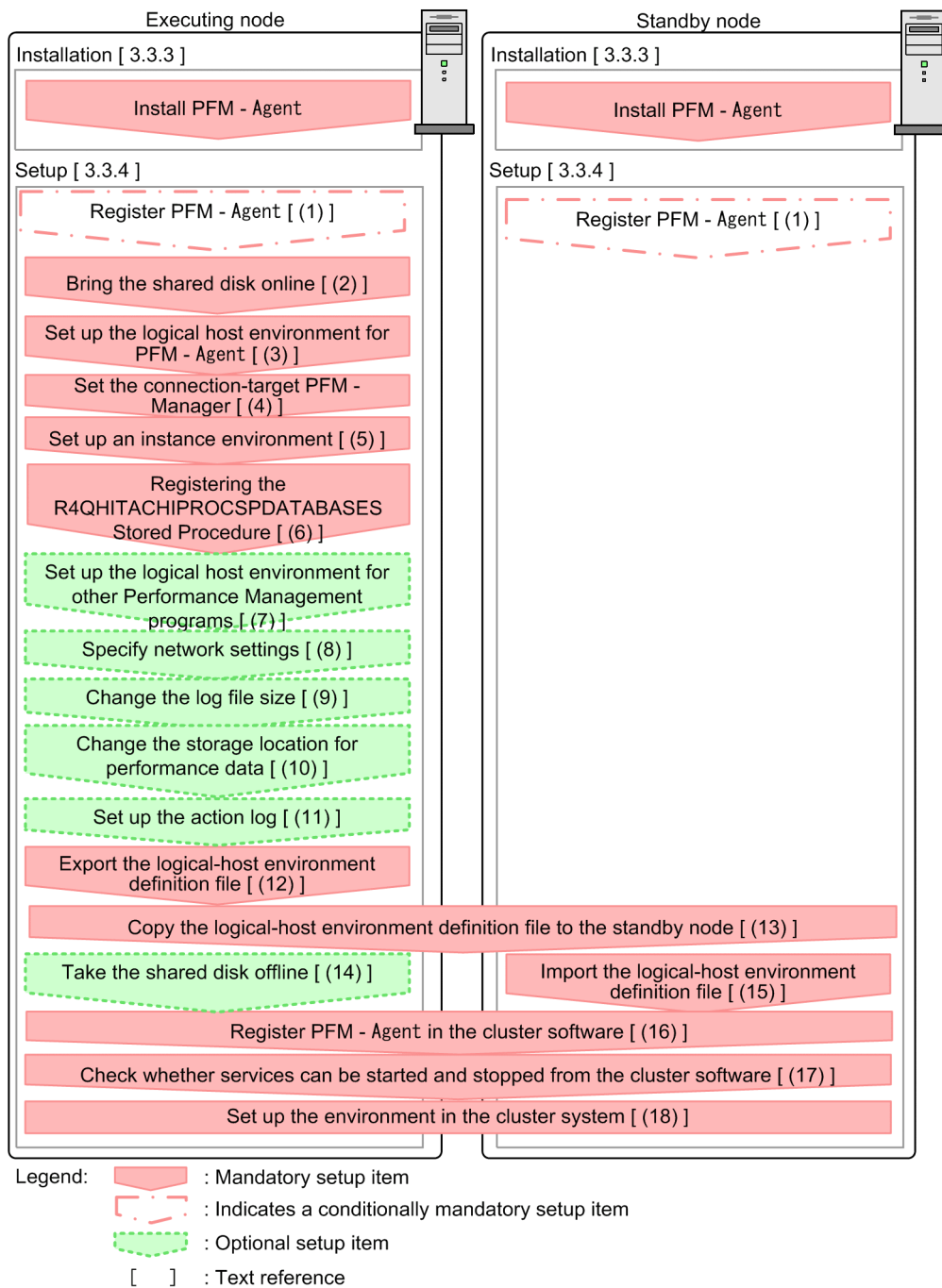

Note:

The definition of PFM - Agent is not inherited from a physical host environment to a logical host environment even when you set up PFM - Agent in a logical host environment. A new environment is created when you build an instance environment in either logical host environment or physical host environment.

Note that for setup commands that require user input, you can select whether to execute such commands interactively or non-interactively.

If you execute a setup command interactively, you need to enter values according to command directives.

If you execute a setup command non-interactively, user input during command execution is not required because such input can be provided instead through values in option specifications or in definition files. Also, batch processing or remote execution can automate setup operations to reduce administrator workload and operating costs. Non-interactive commands are useful for the following cases:

- You want to regularly change the password to be used for connection with monitored systems.
- You want to simplify how to add multiple monitored systems.

For details about commands, see the chapter that explains the commands in the manual JP1/Performance Management Reference.

3.3.2 Preparation for installation and setup

This subsection describes the prerequisites for installation and setup, and provides cautionary notes and other information you should know before installing and setting up PFM - Agent for Microsoft SQL Server.

(1) Prerequisites

The following are the prerequisites for running PFM - Agent for Microsoft SQL Server in a cluster system.

(a) Cluster system

Make sure that the following conditions are satisfied:

- The cluster system is controlled by cluster software.
- The cluster software is able to start and stop PFM - Agent for Microsoft SQL Server on a logical host. Additionally, PFM - Agent for Microsoft SQL Server is able to fail over at the same time when the monitored Microsoft SQL Server fails over.
- Both the executing and standby systems are configured to suppress error reporting to Microsoft.

When an application error occurs, a dialog box giving you the option of reporting the problem to Microsoft appears. Because the dialog box can interfere with failover, you must disable error reporting. If the nodes have not been set up to disable error reporting, take the following steps.

In Windows Server 2008

1. Choose **Control Panel > System and Security > Action Center > Maintenance**.
2. In **Check for solutions to problem reports**, click **Settings**.
3. In the **Choose when to check for solutions to problem reports** dialog box, choose **Never check for solutions (not recommended)**.
4. Click the **OK** button.

In Windows Server 2012

1. Choose **Control Panel > System and Security > Action Center > Maintenance**.
2. In **Check for solutions to unreported problems**, click **Settings**.
3. In the **Windows Error Reporting Configuration** dialog box, choose **I don't want to participate, and don't ask me again**.
4. Click the **OK** button.

In Windows Server 2016

1. Right-click the Windows **Start** menu and then choose **Run** from the displayed menu.
2. Enter `gpedit.msc`, and then click the **OK** button.
The Local Group Policy Editor appears.
3. Click **Computer Configuration, Administrative Templates, Windows Components**, and then **Windows Error Reporting**.
4. In the right pane, right-click **Disable Windows Error Reporting**, and then from the displayed menu, choose **Edit**.
The setting window appears.
5. In the setting window, select the **Enabled** check box.
6. Click the **OK** button.

(b) Shared disk

Make sure that the following conditions are satisfied:

- Each logical host has a shared disk that the standby node can inherit from the executing node.
- The shared disk is physically connected to each node via a Fibre Channel, SCSI, or similar connection.
Performance Management does not support the use of network drives or disks replicated over the network as the shared disk.
- If a failover is requested while a process is accessing the shared disk, the cluster software can take the shared disk offline and force a failover.
- Each instance of Performance Management programs on the same logical host uses the same directory on the shared disk.

Note that you can change the location of the Store database to another directory on the shared disk.

(c) Logical host names and logical IP addresses

Make sure that the following conditions are satisfied:

- Each logical host has a logical host name and a corresponding logical IP address, which the standby node inherits from the executing node.
- Logical host names and logical IP addresses are set in the `hosts` file and on the name server.
- For DNS operation, host names in FQDN format cannot be used. For the logical host name, use the host name with the domain name portion removed.
- Physical host names and logical host names are unique within the system.

Notes:

- Do not specify the physical host name (the host name displayed by the `hostname` command) as the name of the logical host. If you do so, normal communication may not be possible.
- Logical host names can consist of 1 to 32 alphanumeric characters. A logical host name cannot include space characters or any of the following characters:
`/ \ : ; * ? ' " < > | & = , .`
- You cannot specify `localhost`, an IP address, or a host name beginning with a hyphen (-) as a logical host name.

(d) Settings when IPv6 used

Performance Management supports IPv6 environments as well as IPv4 environments as a network configuration. Therefore, Performance Management can operate even in a network configuration in which both an IPv4 environment and an IPv6 environment are used. PFM - Agent for Microsoft SQL Server can communicate with PFM - Manager via IPv6. Note that this explanation applies only when the OS of a host on which PFM - Agent for Microsoft SQL Server is installed is Windows, and the OS of a host on which PFM - Manager is installed is Windows or Linux.

For details about the scope of communication in an environment with both IPv4 and IPv6, see *L. About Communication in IPv4 Environments and IPv6 Environments*.

When you want to use IPv6 for communication, the settings for using IPv6 need to be enabled on both the PFM - Manager host and the PFM - Agent host. In addition, before installing PFM - Agent for Microsoft SQL Server, you need to enable the use of IPv6 on the PFM - Agent host. You have to execute the `jpccconf ipv6 enable` command to enable this setting. If this setting is already enabled, however, you do not need to execute the command. If you want to check whether the use of IPv6 is enabled, execute the `jpccconf ipv6 display` command.

Execute the `jpccconf ipv6 enable` command on both the executing node and the standby node.

For details about the `jpccconf ipv6 enable` command and `jpccconf ipv6 display` command, see the chapter that describes commands in the manual *JPI/Performance Management Reference*. For details about the conditions or occasions for executing the `jpccconf ipv6 enable` command, see the chapter that describes network configuration examples in an environment that includes IPv6 in the *JPI/Performance Management Planning and Configuration Guide*.

When you use IPv6 for communication between a monitored host and PFM - Agent for Microsoft SQL Server, specify the name of a monitored host where name resolution can be performed.

Communication between PFM - Agent for Microsoft SQL Server and a monitoring target is performed with an IP address that can be resolved. Also, if an IPv4 environment and an IPv6 environment are both used, and communication between PFM - Agent for Microsoft SQL Server and the monitoring target fails with an IP address that can be resolved, the communication is not retried by using another IP address.

For example, if communication fails when IPv4 is used, IPv6 is not used to retry communication. Similarly, if communication fails when IPv6 is used, IPv4 is not used to retry communication. Make sure beforehand that a connection can be established.

(2) Information required to set up PFM - Agent for Microsoft SQL Server to run on a logical host

When you set up PFM - Agent for Microsoft SQL Server to run in a logical host environment, you must specify the information shown in the following table, in addition to the environment information required for PFM - Agent for Microsoft SQL Server setup.

Table 3–2: Information required to set up PFM - Agent for Microsoft SQL Server to run on a logical host

Item	Example
Logical host name	jp1-halSQL
Logical IP address	172.16.92.100
Shared disk	s:\jp1

When multiple Performance Management programs are installed on a single logical host, the programs share the same directory on the shared disk.

For details about how much shared disk capacity is needed, see [A. Estimating System Requirements](#).

(3) Cautionary notes on failing over a logical host with PFM - Agent for Microsoft SQL Server

In a system configuration in which PFM - Agent for Microsoft SQL Server runs on a logical host, consider whether you want the entire logical host to fail over when an error occurs in PFM - Agent for Microsoft SQL Server.

If the entire logical host is failed over when an error occurs in PFM - Agent for Microsoft SQL Server, business applications on the same logical host will also be failed over. Failover of these applications may affect any business operations that are in progress.

We recommend that you use one of the following cluster software settings so that errors on PFM - Agent for Microsoft SQL Server do not affect the operations of Microsoft SQL Server:

- Do not monitor operation of PFM - Agent for Microsoft SQL Server
- Do not allow detection of errors in PFM - Agent for Microsoft SQL Server to result in failover

(4) Cautionary notes on upgrading when Microsoft SQL Server runs on a logical host

When you upgrade PFM - Agent for Microsoft SQL Server that runs on a logical host, you need to bring the shared disk on either the executing node or the standby node online.

For details about notes on upgrading the version of PFM - Agent for Microsoft SQL Server, see [G. Migration Procedure and Notes on Migration](#).

(5) Notes when a non-default Microsoft SQL Server port number or the named pipe protocol is used to connect with Microsoft SQL Server

In a cluster environment, PFM - Agent for Microsoft SQL Server uses the TCP/IP protocol to communicate with Microsoft SQL Server.

If port numbers for Microsoft SQL Server are set to other than standard, you need to set **Aliases** by using, for example, an SQL Server configuration manager. Because PFM - Agent for Microsoft SQL Server is a 64-bit application, specify a 64-bit name for **Aliases**^{#2}. If you use the SQL Server configuration manager, set **Aliases** from **SQL Native Client n^{#1} Configuration** in a 64-bit OS environment, and from **SQL Native Client n^{#1} Configuration** in a 64-bit OS environment.

If you use SQL Server Client Network Utility, execute the following file to specify it:

```
%windir%\system32\cliconfg.exe
```

#1

n indicates the version of SQL Server Native Client.

#2

To specify an *alias*, select the **Alias** tab and enter the following values:

- For the default instance:
Server name: *SQL_HOST*^{#3}
Network libraries: TCP/IP
Port Number: Port number for Microsoft SQL Server
Server alias: *SQL_HOST*^{#3}
- For the named instance:
Server name: *SQL_HOST*^{#3}\instance-name^{#4}
Network libraries: TCP/IP
Port Number: Port number for Microsoft SQL Server
Server alias: *SQL_HOST*^{#3}\instance-name^{#4}

#3

SQL_HOST value for PFM - Agent for Microsoft SQL Server

#4

Instance name of PFM - Agent for Microsoft SQL Server

Note that depending on your version, the settings may look different. In that case, replace them to suit your own environment.

To check if the specified *alias* works for connecting with Microsoft SQL Server, use the `sqlcmd` command. For details, see your Microsoft SQL Server documentation.

3.3.3 Installation procedure

Install PFM - Agent for Microsoft SQL Server on the executing node and the standby node.

Important

You must install PFM - Agent for Microsoft SQL Server on a local disk. Do not install it on a shared disk.

The installation procedure is the same as the installation procedure in a non-cluster system. For details about the installation procedure, see [2.1.3 Installation procedure](#).

3.3.4 Setup procedure

This subsection describes how to set up Performance Management to run in a cluster system.

When you want to operate Performance Management in a cluster system, setup is needed on both the executing node and the standby node. You must perform setup on the executing node before performing the setup on the standby node.

Executing indicates a task to be performed on the executing node. **Standby** indicates a task to be performed on the standby node. **Option** indicates a setup item that is required depending on the environment or an optional setup item used when the default is to be changed.

(1) Register PFM - Agent for Microsoft SQL Server

Executing

Standby

Option

To perform integrated management of PFM - Agent using PFM - Manager and PFM - Web Console, you must register PFM - Agent for Microsoft SQL Server with PFM - Manager and PFM - Web Console.

You will need to register PFM - Agent for Microsoft SQL Server in the following cases:

- You add a new instance of PFM - Agent for Microsoft SQL Server to the Performance Management system.
- You update the data model version of an instance of PFM - Agent for Microsoft SQL Server that is already registered.

Registration is performed separately for PFM - Manager and PFM - Web Console. The registration procedure is the same as in the registration procedure in a non-cluster system.

For details about the procedure, see *2.1.4(1) Registering PFM - Agent for Microsoft SQL Server*.

(2) Bring the shared disk online

Executing

Make sure that the shared disk is online. If the shared disk is not online, use the cluster software or the volume manager to bring it online.

(3) Set up the logical host environment for PFM - Agent for Microsoft SQL Server

Executing

Execute the `jpccconf ha setup` command to set up the logical host environment. When you execute the command, the necessary files are copied to the shared disk, the logical host definition is set up, and the logical host environment is created.

Note:

Before you execute the command, stop all Performance Management programs and services throughout the Performance Management system. For details about how to stop services, see the chapter on starting and stopping Performance Management in the *JP1/Performance Management User's Guide*.

To set up the logical host environment:

1. Execute the `jpccconf ha setup` command to create the logical host environment for PFM - Agent for Microsoft SQL Server.

Execute the command as follows:

```
jpccconf ha setup -key SQL -lhost jp1-halSQL -d S:\jp1
```

Use the `-lhost` option to specify the logical host name. In the example above, the logical host name is `jp1-halSQL`. For DNS operation, specify a logical host name with the domain name portion removed.

Specify the name of the shared disk directory as the environment directory name of the `-d` option. For example, if you specify `-d S:\jp1`, the directory `S:\jp1\jp1pc` is created, and the files for the logical host environment are created in that directory.

2. Execute the `jpccconf ha list` command to check the logical host settings.

Execute the command as follows:

```
jpccconf ha list -key all
```

Confirm that the logical host environment you created has been set up correctly.

(4) Set the connection-target PFM - Manager Executing

Execute the `jpccconf mgrhost define` command to specify which PFM - Manager is to manage PFM - Agent for Microsoft SQL Server.

1. Execute the `jpccconf mgrhost define` command to set the connection-target PFM - Manager.

Execute the command as follows:

```
jpccconf mgrhost define -host jp1-hal -lhost jp1-halSQL
```

Use the `-host` option to specify the host name of the connection-target PFM - Manager. If that PFM - Manager is running in a logical host environment, specify the logical host name of the PFM - Manager in the `-host` option. In the example above, the logical host name of PFM - Manager is `jp1-hal`.

Use the `-lhost` option to specify the logical host name of PFM - Agent for Microsoft SQL Server. In the example above, the logical host name of PFM - Agent for Microsoft SQL Server is `jp1-halora`.

Although an example of interactive command execution is shown here, the `jpccconf mgrhost define` command can be also executed non-interactively. For details about the `jpccconf mgrhost define` command, see the chapter that describes commands in the manual *JPI/Performance Management Reference*.

(5) Set up an instance environment Executing

Execute the `jpccconf inst setup` command to set up an instance environment for PFM - Agent for Microsoft SQL Server.

The setup procedure is the same as the setup procedure in a non-cluster system, except that, in a cluster system, you must specify the logical host name in the `-lhost` option when executing the `jpccconf inst setup` command.

In a cluster system, the `jpccconf inst setup` command is executed in the following format:

```
jpccconf inst setup -key SQL -lhost logical-host-name -inst instance-name
```

As the agent log output folder (the value of `log_path`), specify the path of a folder that is on the shared disk.

Although an example of interactive command execution is shown here, the `jpccconf inst setup` command can be also executed non-interactively. For details about the `jpccconf inst setup` command, see the chapter that describes commands in the manual *JPI/Performance Management Reference*.

For details about other settings and procedures, see [2.1.4\(2\) Setting up an instance environment](#).

(6) Registering the A4QHITACHIPROCSPDATABASES Stored Procedure

Executing

Option

Register the stored procedure in order for PFM - Agent for Microsoft SQL Server to obtain the names and the sizes of the databases from Microsoft SQL Server

The registering procedure is the same as that of the non-cluster-system. For details, see [2.1.4\(3\) Registering the A4QHITACHIPROCSPDATABASES Stored Procedure](#).

(7) Set up the logical host environment for other Performance Management programs Executing Option

At this point, set up any other Performance Management programs, such as PFM - Manager or PFM - Agent, on the same logical host.

For details about how to set up these products, see the chapters on setup and operation in a cluster system in the *JPI/Performance Management User's Guide*, and the chapter on operation in a cluster system in the manuals for the applicable version of PFM - Agent.

(8) Specify network settings Executing Option

This setup task is necessary only when you change the network settings to match the configuration in which Performance Management is used.

The following are the two network setting items:

- IP addresses

To specify the IP address used by Performance Management in a network environment where multiple LANs are connected, directly edit the contents of the `jpchosts` file.

After editing the file, copy it from the executing node to the standby node.

For details about how to set IP addresses, see the chapter on installation and setup in the *JPI/Performance Management Planning and Configuration Guide*.

- Port numbers

If Performance Management programs will communicate with each other through a firewall, use the `jpccconf port` command to set the port numbers.

For details about how to set port numbers, see the chapter on installation and setup and the chapters on setup and operation in a cluster system in the *JPI/Performance Management Planning and Configuration Guide*.

(9) Change the size of log files Executing Option

Performance Management outputs its operating status to a set of proprietary log files called a *common message log*. By default, the common message log consists of two 2,048 KB files. Perform this setting if you want to change the default file size.

For details, see the chapter on installation and setup in the *JPI/Performance Management Planning and Configuration Guide*.

(10) Change the storage location of performance data Executing Option

Perform this setting only if you want to change the folders where the database of performance data managed by PFM - Agent for Microsoft SQL Server is saved, backed up, exported, or imported.

For details, see [2.4.1 Changing the storage location of performance data](#).

(11) Setting up the action log Executing Option

This setting is required to output action log when alarm occur. The action log stores history information that is output in conjunction with the alarms for thresholds related to system load and other conditions.

For details about how to set up the action log, see [J. Outputting Action Log Information](#).

(12) Export the logical-host environment definition file Executing

Once you have created the logical host environment for PFM - Agent for Microsoft SQL Server, export the environment definition as a file. In the export process, a file containing the collective definition information for all Performance Management programs set up on that logical host is output. Export the environment definition only after you have set up all additional Performance Management programs on the logical host.

To export the environment definition of the logical host:

1. Execute the `jpccconf ha export` command to export the environment definition of the logical host.

The definition information for the logical host environment you created is output to an export file. You can give this file any name you wish.

For example, execute the command as follows to output the logical host environment definition to the file `lhostexp.txt`:

```
jpccconf ha export -f lhostexp.txt
```

Although an example of interactive command execution is shown here, the `jpccconf ha export` command can be also executed non-interactively. For details about the `jpccconf ha export` command, see the chapter that describes commands in the manual *JPI/Performance Management Reference*.

(13) Copy the logical-host environment definition file to the standby node

ExecutingStandby

Copy the file you exported in (12) *Export the logical-host environment definition file* from the executing node to the standby node.

(14) Take the shared disk offline Executing Option

Use the cluster software or the volume manager to take the shared disk offline. Note that if you intend to continue using the shared disk, you do not need to take it offline at this point.

(15) Import the logical-host environment definition file Standby

On the standby node, import the exported file you copied from the executing node.

Use the `jpccconf ha import` command to set up the environment definition for the Performance Management programs of the logical host that you created on the executing node so that they run on the standby node. If more than one Performance Management program was installed on the logical host, the definition information for all of the programs is imported in batch form.

Note that the shared disk does not need to be online when you execute this command.

To import the logical-host environment definition file:

1. Execute the `jpccconf ha import` command to import the environment definition of the logical host.

Execute the command as follows:

```
jpccconf ha import -f lhostexp.txt
```

Although an example of interactive command execution is shown here, the `jpccconf ha import` command can be also executed non-interactively. For details about the `jpccconf ha import` command, see the chapter that describes commands in the manual *JPI/Performance Management Reference*.

When you execute the command, the settings on the standby node are changed to reflect the environment described in the export file. This sets up the standby node to run PFM - Agent for Microsoft SQL Server as a logical host.

If you used the `jpccconf ha import` command to assign fixed port numbers during setup, the same port numbers will take effect on the standby node.

- Execute the `jpccconf ha list` command to check whether the logical host is set up correctly.

Execute the command as follows:

```
jpccconf ha list -key all
```

Check whether the same output is displayed as when you executed `jpccconf ha list` on the executing node.

(16) Register PFM - Agent for Microsoft SQL Server in the cluster software

Executing

Standby

If you intend to use Performance Management programs in a logical host environment, make sure that the programs are registered in the cluster software. Also, set up the environment so that the Performance Management programs are started and stopped based on instructions from the cluster software.

For details about how to register PFM - Agent for Microsoft SQL Server in the cluster software, see your cluster software documentation.

For the dependency settings specified if PFM - Agent for Microsoft SQL Server is on the PFM - Manager logical host, see the chapter on cluster system setup and operation in the JP1/Performance Management User's Guide.

This subsection describes how to register PFM - Agent for Microsoft SQL Server in your cluster software, using the settings for Windows WSFC as an example.

Register the following services of PFM - Agent for Microsoft SQL Server in the cluster software:

Table 3–3: PFM - Agent for Microsoft SQL Server services to be registered in the cluster software

No.	Name	Service name	Dependencies
1	PFM - Agent Store for Microsoft(R) SQL Server <i>instance-name</i> [LHOST]	JP1PCAGT_QS_ <i>instance-name</i> [LHOST]	IP address resource Physical disk resource
2	PFM - Agent for Microsoft(R) SQL Server <i>instance-name</i> [LHOST]	JP1PCAGT_QA_ <i>instance-name</i> [LHOST]	Cluster resource in No. 1
3	PFM - Action Handler [LHOST]	JP1PCMGR_PH [LHOST]	IP address resource Physical disk resource

Replace *LHOST* with the logical host name. For example, if the instance name is `SQL1` and the logical host name is `jp1-halSQL`, the display name of the service will be `PFM - Agent Store for Microsoft (R) SQL Server SQL1 [jp1-halSQL]`, and the service name will be `JP1PCAGT_QS_SQL1 [jp1-halSQL]`.

For WSFC, register these services as WSFC resources. Set each resource as follows:

- In **Resource type**, register the resource as **Generic Service**.
- Set **Dependencies** as shown in Table 3-3.
- Do not set **Startup parameters** or **Registry Replication**[#].

#

This tab is displayed only in a Windows Server 2008 R2 environment.

- Set the **Policies** tab in **Properties** by taking into account whether you want a failover to occur in the event of a Performance Management program failure.

For example, to trigger a failover when a failure occurs in PFM - Agent for Microsoft SQL Server, set the **Policies** tab as follows:

- Select the If resource fails, attempt restart on current node radio button.
- Select the If restart is unsuccessful, fail over all resources in this service or application check box[#].
- -In principle, set Maximum restarts in the specified period: to 3.

#

In the case of Windows Server 2012 or later, the If restart is unsuccessful, fail over all resources in this Role check box is used instead.

Note:

The cluster software is responsible for starting and stopping the services that have been registered in it. Set **Startup type** for those services to **Manual** to prevent them from starting automatically when the OS starts. When you set up a service using the `jpccconf ha setup` command, **Startup type** for the service will be set to **Manual**.

- When registered PFM - Agent for Microsoft SQL Server and PFM - Agent Store for Microsoft SQL Server in a cluster system, do not set dependencies between PFM - Agent for Microsoft SQL Server and Microsoft SQL Server. Setting the dependencies might result in delayed failover.
- When linked with the integrated management product (JP1/IM), specify the dependency settings so that the service of JP1/Base stops after the service of PFM - Agent for Microsoft SQL Server stops.

(17) Check whether services can be started and stopped from the cluster software

Executing

Standby

Check whether the cluster software is operating correctly by using it to issue start and stop requests to Performance Management programs on each node.

(18) Set up the environment in the cluster system

Executing

Standby

After setting up the Performance Management programs, use PFM - Web Console to set up the environment for the programs. You will then be able to display reports on the operating status of monitoring targets, and notify users whenever a problem occurs.

For details about setting up the environment for Performance Management programs, see the chapters on setup and operation in a cluster system in the *JP1/Performance Management User's Guide*.

3.4 Setup cancellation and uninstallation

This section describes how to cancel setup of PFM - Agent for Microsoft SQL Server and how to uninstall PFM - Agent for Microsoft SQL Server in a cluster system.

For details about how to cancel setup of PFM - Manager and how to uninstall PFM - Manager, see the chapters on setup and operation in a cluster system in the *JP1/Performance Management User's Guide*.

3.4.1 Setup cancellation and uninstallation workflow of PFM - Agent for Microsoft SQL Server

The following figure shows the setup cancellation and uninstallation workflow of PFM - Agent for Microsoft SQL Server in a cluster system.

Figure 3–6: Setup cancellation and uninstallation workflow of PFM - Agent for Microsoft SQL Server running on a logical host in a cluster system (Windows)

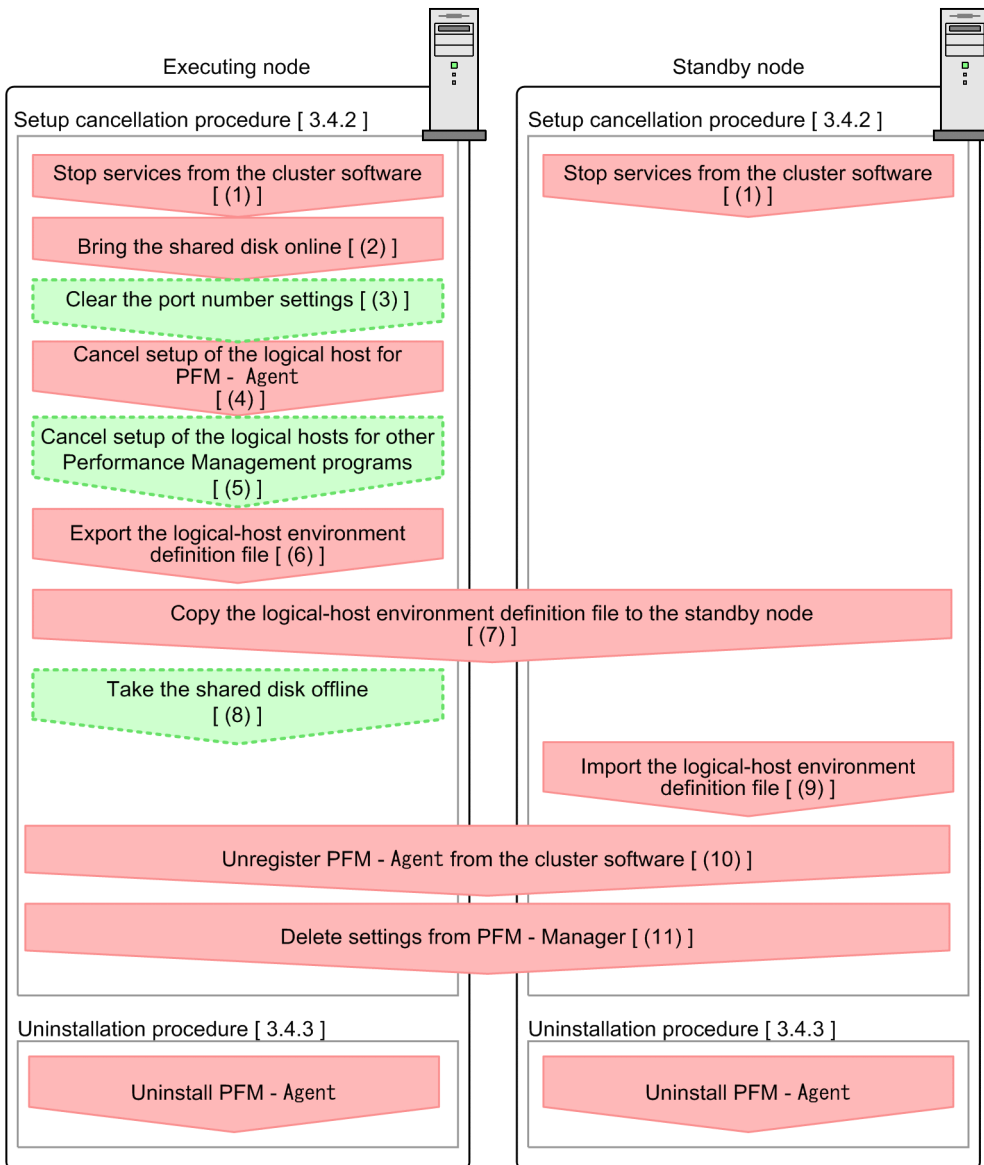

Legend:

 : Mandatory item

 : Optional item

[] : Text reference

3.4.2 Setup cancellation procedure

This section describes the procedure for canceling setup of the logical host environment. There are separate procedures for the executing node and the standby node. Cancellation of setup must be performed first on the executing node and then on the standby node.

Executing indicates a task to be performed on the executing node. **Standby** indicates a task to be performed on the standby node. **Option** indicates a setup item that is required depending on the environment or an optional setup item used when the default is to be changed.

The following subsections describe how to cancel setup of PFM - Agent for Microsoft SQL Server.

(1) Stop services from the cluster software **Executing** **Standby**

Stop all the Performance Management programs and services running on the executing and standby nodes by using instructions from the cluster system. For details about how to stop the programs and services, see the documentation for your cluster software.

(2) Bring the shared disk online **Executing**

Make sure that the shared disk is online. If the shared disk is not online, use the cluster software or the volume manager to bring it online.

(3) Clear the port number settings **Executing** **Option**

Perform this step only if you are running a firewall environment, and you used the `jpccconf port` command to set port numbers during setup.

For details about how to clear the port number settings, see the chapter on uninstallation and `unsetup` in the *JPI/Performance Management Planning and Configuration Guide* and see the chapters on setup and operation in a cluster system in the *JPI/Performance Management User's Guide*.

(4) Cancel setup of the logical host environments for PFM - Agent for Microsoft SQL Server **Executing**

The following procedure shows how to cancel setup of the logical host environment for the executing node.

Note:

If a logical host environment is deleted while the shared disk is offline, the logical host settings are deleted from the physical host, but the folders and files are not deleted from the shared disk. In such cases, you must bring the shared disk online and then manually delete the `jp1pc` folder under the environment folder.

1. Execute the `jpccconf ha list` command to check the logical host settings.

Execute the command as follows:

```
jpccconf ha list -key all -lhost jp1-halSQL
```

Before canceling setup of the logical host environment, check the current settings, including the logical host name and the path to the shared disk.

2. Execute the `jpccconf inst unsetup` command to delete the instance environment.

Execute the command as follows:

```
jpccconf inst unsetup -key SQL -lhost jp1-halSQL -inst SQL1
```

Although an example of interactive command execution is shown here, the `jpccconf inst unsetup` command can be also executed non-interactively. For details about the `jpccconf inst unsetup` command, see the chapter that describes commands in the manual *JPI/Performance Management Reference*.

When you execute the `jpccconf inst unsetup` command, the settings that allow the instance to start on the logical host are deleted. The files on the shared disk that relate to the logical host are also deleted.

3. Execute the `jpccconf ha unsetup` command to delete the logical host environment for PFM - Agent for Microsoft SQL Server.

Execute the command as follows:

```
jpccconf ha unsetup -key SQL -lhost jp1-halSQL
```

When you execute the `jpccconf ha unsetup` command, the settings that allow the instance to start on the logical host are deleted. Files on the shared disk that relate to the logical host are also deleted.

4. Use the `jpccconf ha list` command to check the logical host settings.

Execute the command as follows:

```
jpccconf ha list -key all
```

Confirm that PFM - Agent for Microsoft SQL Server has been deleted from the logical host environment.

(5) Cancel setup of the logical host environments for other Performance Management programs Executing Option

If there are Performance Management programs for which you want to cancel setup in addition to PFM - Agent for Microsoft SQL Server on the same logical host, cancel setup of these at this point.

For details about how to cancel setup, see the chapters on setup and operation in a cluster system in the *JPI/Performance Management User's Guide*, or the chapters on operation in a cluster system in the applicable PFM - Agent manual.

(6) Export the logical-host environment definition file Executing

After you have deleted PFM - Agent for Microsoft SQL Server from the logical host, export the environment definition as a file.

Performance Management allows you to synchronize the environments on the executing node and standby node by exporting the environment definition from one node and importing it into the other.

When you import the environment definition (without the Performance Management component) from the executing node into the standby node, the imported environment definition is compared with the existing environment definition (containing the Performance Management component) and the difference between the two is verified. The Performance Management environment definition is then cleared from the standby node so that both nodes have the same environment.

To export the logical-host environment definition file:

1. Execute the `jpccconf ha export` command to export the logical host environment definition.

The definition information for the logical host environment of Performance Management is output to an export file. You can give this file any name you wish.

For example, execute the command as follows to output the logical host environment definition to the file `lhostexp.txt`:

```
jpccconf ha export -f lhostexp.txt
```

Although an example of interactive command execution is shown here, the `jpccconf ha export` command can be also executed non-interactively. For details about the `jpccconf ha export` command, see the chapter that describes commands in the manual *JPI/Performance Management Reference*.

(7) Copy the logical-host environment definition file to the standby node

Executing

Standby

Copy the file you exported in (6) *Export the logical-host environment definition file* from the executing node to the standby node.

(8) Take the shared disk offline

Executing

Option

Use the cluster software or the volume manager to take the shared disk offline. Note that if you intend to continue using the shared disk, you do not need to take it offline at this point.

(9) Import the logical-host environment definition file

Standby

On the standby node, import the exported file you copied from the executing node in order to synchronize the environment definitions of both nodes. You do not need to take the shared disk offline on the standby node before importing the file. Note that the shared disk does not need to be offline when you execute this command.

To import the logical-host environment definition file:

1. Execute the `jpccconf ha import` command to import the environment definition of the logical host.

Execute the command as follows:

```
jpccconf ha import -f lhostexp.txt
```

Although an example of interactive command execution is shown here, the `jpccconf ha import` command can be also executed non-interactively. For details about the `jpccconf ha import` command, see the chapter that describes commands in the manual *JPI/Performance Management Reference*.

When you execute the command, the environment on the standby node is changed to reflect the environment described in the export file. This clears the settings that allow PFM - Agent for Microsoft SQL Server to start on the logical host. These settings are also cleared for any other Performance Management programs for which you cancel setup on the logical host.

If you used the `jpccconf port` command during setup to assign fixed port numbers, the port numbers will no longer be assigned.

2. Execute the `jpccconf ha list` command to check the logical host settings.

Execute the command as follows:

```
jpccconf ha list -key all
```

Confirm whether the same output is displayed as when you executed the `jpccconf ha list` command on the executing node.

(10) Unregister PFM - Agent for Microsoft SQL Server in the cluster software

Executing

Standby

Delete the settings related to PFM - Agent for Microsoft SQL Server on the logical host from the cluster software.

For details about deleting these settings, see the documentation for your cluster software.

(11) Delete settings from PFM - Manager

Executing

Standby

Log in to PFM - Manager from PFM - Web Console, and delete the definition relating to the PFM - Agent for Microsoft SQL Server for which you want to cancel setup.

To delete the definition:

1. Start the PFM - Manager service.
2. If you have stopped the PFM - Manager services from the cluster software as described in *(1) Stop services from the cluster software*, use the cluster software to start the PFM - Manager services. For details about how to start the services, see the cluster software documentation.
3. From PFM - Web Console, delete the agent.
4. Delete the agent information in PFM - Manager.

For example, if PFM - Manager is running on the logical host `jp1-hal`, and PFM - Agent for Microsoft SQL Server is running on the logical host `jp1-halora`, execute the following command to delete the agent:

```
jpctool service delete -id service-ID -host jp1-halSQL -lhost jp1-hal
```

In *service-ID*, specify the service ID of the agent you want to delete.

5. Restart the PFM - Manager service.
For details about how to start services, see the chapter on starting and stopping Performance Management in the *JP1/Performance Management User's Guide*.
6. Apply the service information of the PFM - Manager host.
In order to update the PFM - Web Console host to reflect the deletion of service information, synchronize the agent information of the PFM - Manager host and that of the PFM - Web Console host. Use the `jpctool service sync` command to synchronize the agent information.

3.4.3 Uninstallation procedure

Uninstall PFM - Agent for Microsoft SQL Server from the executing and standby nodes.

The uninstallation procedure is the same as the uninstallation procedure in a non-cluster system. For details, see [2.2.3 Procedure for uninstallation](#).

Notes:

- Before you uninstall PFM - Agent for Microsoft SQL Server, stop all Performance Management programs and services on the node from which you are uninstalling PFM - Agent for Microsoft SQL Server.
- If you uninstalled PFM - Agent for Microsoft SQL Server without deleting the logical host environment, the environment directory may remain on the disk. In this case, delete the environment directory manually.

3.5 Changing the system configuration of PFM - Agent for Microsoft SQL Server

Depending on the change in the network configuration of a monitored system or a change in the host name, you might need to change the system configuration of PFM - Agent for Microsoft SQL Server.

When you change the system configuration of PFM - Agent for Microsoft SQL Server, you also need to change the settings of PFM - Manager or PFM - Web Console. For details about how to change the system configuration of Performance Management, see the chapter that describes installation and setup in the *JPI/Performance Management Planning and Configuration Guide*. When you change the logical host name, PFM - Agent for Microsoft SQL Server requires you to update the `SQL_HOST` item with the new host name by using the `jpccconf inst setup` command. For details about how to change, see [3.6.1 Updating an instance environment](#).

3.6 Changing the operation of PFM - Agent for Microsoft SQL Server

This section describes how to change the operation of PFM - Agent for Microsoft SQL Server in a cluster system. For details about how to change the configuration of the whole Performance Management system, see the chapter on the installation and setup in the *JPI/Performance Management Planning and Configuration Guide*.

3.6.1 Updating an instance environment

When you update an instance environment in a cluster system, you first check the logical host name and the name of the instance that you want to update. You update the instance information on the executing node.

Before you change the information items, see in advance [2.4.2 Updating an instance environment](#). For details about Microsoft SQL Server instance information, see your Microsoft SQL Server documentation.

Use the `jpccconf ha list` command to check the instance name. To update an instance environment, use the `jpccconf inst setup` command.

Updating an instance environment involves the steps described below. To update multiple instance environments, repeat the procedure for each instance environment.

1. Check the logical host name and the instance name

Execute the `jpccconf ha list` command specified with the service key that indicates the PFM - Agent for Microsoft SQL Server in the instance environment that is to be updated:

For example, if you want to check the logical host name and instance name of PFM - Agent for Microsoft SQL Server, execute the following command:

```
jpccconf ha list -key SQL
```

For example, if you execute the command in the system with logical host name `jp1_SQL` and instance name `SQL1`, the command will list the following information:

Logical Host Name	Key	Environment Directory Path to the logical host environment directory	Instance Name
jp1_SQL	agtq		SQL1

2. If the PFM - Agent for Microsoft SQL Server service is active in the instance environment that is to be updated, use the cluster software to stop the service.
3. If the shared disk is unmounted when you stop the service, use the cluster software or the volume manager to mount it.
4. Execute the `jpccconf inst setup` command specified with the service key and the instance name that indicate the PFM - Agent for Microsoft SQL Server in the instance environment that is to be updated.

For example, if you are updating the instance environment with logical host name `jp1_SQL` and instance name `SQL1`, execute the following command:

```
jpccconf inst setup -key SQL -lhost jp1_SQL -inst SQL1
```

5. Update the instance information for PFM - Agent for Microsoft SQL Server.

Enter the information in accordance with the command's instructions. For details about the instance information of PFM - Agent for Microsoft SQL Server, see [2.4.2 Updating an instance environment](#). The current settings are displayed (except for the value of `Microsoft SQL Server_passwd`). To use the displayed value, press the Enter key. When you have finished entering information, the instance environment is updated.

6. Use the cluster software to restart the service in the updated instance environment.

For details about the starting the service, see the chapter on starting and stopping Performance Management in a cluster system in the *JP1/Performance Management User's Guide*.

Note:

If you want to change an item that cannot be updated, delete the instance environment and then re-create it.

For details about the commands used in this procedure, see the chapter on the commands in the manual *JP1/Performance Management Reference*.

3.6.2 Exporting and importing the logical-host environment definition file

You must export and import the logical-host environment definition file only if you perform any one of these operations listed below:

- When you set up the logical host environment, the instance environment, or the monitoring target, you also change the node system on the logical host.

For details about how to set up the PFM - Agent for Microsoft SQL Server logical host, see [3.3.4\(3\) Set up the logical host environment for PFM - Agent for Microsoft SQL Server](#).

For details about how to set up the instance environment, see [3.3.4\(5\) Set up an instance environment](#).

- When you set up the logical host environment of other Performance Management programs, you perform an operation that requires exporting and importing the logical-host environment definition file.

For details about the procedures for setting up the logical host environment for other Performance Management program, see [3.3.4\(7\) Set up the logical host environment for other Performance Management programs](#).

- When you specify network setting, you set the port numbers.

For details about how to specify the network settings, see [3.3.4\(8\) Specify network settings](#).

For details about the procedure for exporting and importing the logical-host-environment definition files, see from [3.3.4\(12\) Export the logical-host environment definition file](#) to [3.3.4\(15\) Import the logical-host environment definition file](#).

Note that you do not have to export and import the logical-host environment definition file when you update a monitoring target host and/or an instance environment.

For details about how to update a monitoring target, see [3.6.1 Updating an instance environment](#).

3.7 Notes on operating PFM - Agent for Microsoft SQL Server in a cluster system

This section provides notes on operating PFM - Agent for Microsoft SQL Server in a cluster system.

3.7.1 Host name in the collected performance data

The performance data PFM - Agent for Microsoft SQL Server collects includes a record that contains fields related to the host name. In the case of PFM - Agent for Microsoft SQL Server running on a logical host, the value of the Host field is either the physical host name or the logical host name. The table 3-4 lists the records containing the host-name-related field:

Table 3–4: Records containing the host-name-related field

Record name	Field name	Stored host name	Description
Process Detail (PD_PDET)	Host	Physical host / logical host	Host name for the process running on the Microsoft SQL Server host.

3.7.2 Log output for a cluster system

If the monitoring-target Microsoft SQL Sever is in a cluster configuration, the following log information (example) is output to the log file because a failover occurs on a Microsoft SQL Server host and the Microsoft SQL Server on that host stops.

Regardless of this error message, PFM - Agent for Microsoft SQL Server continues to operate properly. After the startup process of the monitoring-target Microsoft SQL Server is completed, PFM - Agent for Microsoft SQL Server continues to collect the records.

Log information (examples):

Common message log file jpclog (the message is output only when Agent starts):

```
2004/10/25 18:22:25 jpcagtq 00002140 00002124 PWBsqlCollector 4241
KAVF21400-W An attempt to connect to the SQL Server has failed.
```

Agent log file agtqerr01.log (the message is output every time a record is collected)

```
2004/10/25 18:24:23 jpcagtq 00002140 00002124 Sqlservado.cpp 0267
E Error Code = 0x80004005, Error Description = [DBNETLIB]
[ConnectionOpen (Connect().)]SQL Server does not exist or access
is denied
```

3.7.3 About service dependencies

When operating PFM - Agent for Microsoft SQL Server in a cluster system, if dependencies are set between the Agent Store service and Microsoft SQL Server resources, PFM - Agent for Microsoft SQL Server stops and then Microsoft SQL Server stops. Therefore, if a failover occurs during record collection, Microsoft SQL Server does not stop immediately because the process to stop is performed after the record collection ends.

Do not set dependencies between PFM - Agent for Microsoft SQL Server and Microsoft SQL Server. By doing this, Microsoft SQL Server might stop before PFM - Agent for Microsoft SQL Server. At this time, the records are not collected.

3.7.4 Timeout

- When you operate PFM - Agent for Microsoft SQL Server in a cluster configuration and a failover occurs, PFM - Agent for Microsoft SQL Server stops after its record collection is completed. Thus, it may take time to stop PFM - Agent for Microsoft SQL Server. In this case, change the following instance information and adjust the query timeout value when accessing the databases.

- `TIMEOUT`

For details about how to change the instance information, see [2.1.4\(2\) Setting up an instance environment](#).

- When you operate PFM - Agent for Microsoft SQL Server in a cluster configuration and a failover occurs, PFM - Agent for Microsoft SQL Server tries to reconnect to the Microsoft SQL Server host. Thus, it may take time to stop the PFM - Agent for Microsoft SQL Server processes. In this case, change the following instance information and adjust the connection timeout value.

- `LOGIN_TIMEOUT`

For details about how to change the instance information, see [2.1.4\(2\) Setting up an instance environment](#).

4

Monitoring Template

This chapter describes the monitoring template for PFM - Agent for Microsoft SQL Server.

Overview of the monitoring template

The Performance Management products enable you to define alarms and reports with the following methods:

- Using alarms and reports defined by PFM - Agent for Microsoft SQL Server without change.
- Copying and customizing the alarms and reports defined by PFM - Agent for Microsoft SQL Server.
- Using the wizard to define new reports.

Alarms and reports provided by a PFM - Agent for Microsoft SQL Server constitute a *monitoring template*. Because all required information is already defined for the alarms and reports in a monitoring template, you can use them as provided, or customize them as appropriate for your environment. This enables you to complete the preparations for monitoring the operating status of a desired program without having to use the wizard to define new reports.

This chapter describes the alarm and report settings in the monitoring template that are defined by PFM - Agent for Microsoft SQL Server.

For details about using the monitoring template, see the chapter on creating reports used for operation analysis or the chapter on alarm-based operation monitoring in the *JP1/Performance Management User's Guide*.

Note:

The threshold specified for the alarms in the monitoring template is a reference example. When you use an alarm in the monitoring template, copy it and set an appropriate threshold according to the environment and the OS.

Format of alarm explanations

This section shows the format used to explain alarms. The manual lists the alarms in alphabetical order.

Alarm name

Indicates the name of an alarm in the monitoring template.

Overview

Provides an overview of the target that can be monitored by the alarm.

Main settings

Shows the main settings of the alarm in a table. The alarm settings in the table correspond to the settings in the Properties window that appears when you click an alarm icon on the **Alarms** window of PFM - Web Console and then click the **Properties** method. For details about each alarm setting, see the Properties window for the particular alarm in PFM - Web Console.

Hyphens (--) in the *Setting* column of the table indicate that any value set for the item will be invalid.

If an error condition is the same as a warning condition in a conditional expression, only the alarm event for the error is issued.

Related reports

Shows the monitoring template reports related to the alarm. You can view the reports by clicking an agent icon on the **Agents** window of PFM - Web Console, and then clicking the  icon for the **Display Alarm Status** method.

Notes of alarms

When PFM - Agent for Microsoft SQL Server does not connect to the monitoring target Microsoft SQL Server, PFM - Agent for Microsoft SQL Server does not detect any alarms except Server Status.

List of alarms

The alarms defined in a PFM - Agent for Microsoft SQL Server monitoring template are summarized in an alarm table called `PFM SQL Template Alarms 11.50`. Here, `11.50` indicates an alarm table version. This alarm table is stored in the `SQL` folder that is displayed on the **Alarms** window of PFM - Web Console. The following table describes the alarms defined in the monitoring template.

Table 4–1: List of alarms (monitoring template)

Alarm name	What is monitored
Blocked Sessions	Number of sessions that are waiting for lock releases by other sessions.
Cache Usage	Rate at which the desired data was found inside the data cache instead of being read from a disk
CPU Usage	Top 10 sessions that are currently using the largest numbers of CPU cycles This alarm cannot be used.
Database Space	Space usage in each database in Microsoft SQL Server
Log Space Usage	Top 10 databases that are consuming the largest amounts of log space
Network Error	Impact of Microsoft SQL Server on network
Server Status	Availability of the Microsoft SQL Server instance

Blocked Sessions

Overview

The Blocked Sessions alarm monitors the number of sessions on the Microsoft SQL Server that are waiting for lock releases by other sessions.

Main settings

Alarm properties in PFM - Web Console		Setting
Item	Detailed item	
Main Information	Product	SQL(8.0)
	Alarm message	%CVS session(s) are blocked
	Enable alarm	Selected
	Alarm notification	Notify when the state changed
	Notification target	State changes for the alarm
	Evaluate all data	Not selected
	Monitoring time range	Always
	Report alarm when the following damping condition is reached	Not selected
	occurrence(s) during	--
	interval(s)	--
Alarm Conditions	Record	Server Detail (PD)
	Field	Blocked Processes
	Abnormal condition	Blocked Processes > 2
	Warning condition	Blocked Processes > 0
Actions	E-mail	--
	Command	--
	SNMP	Abnormal, Warning, Normal

Legend:

--: The setting is always invalid.

Related report

Reports/SQL/Troubleshooting/Real-Time/Blocking Locks (8.0)

Cache Usage

Overview

The Cache Usage alarm monitors the rate at which the desired data was found inside the data cache and did not need to be read from a disk.

Main settings

Alarm properties in PFM - Web Console		Setting
Item	Detailed item	
Main Information	Product	SQL(8.0)
	Alarm message	Cache hit %CVS%
	Enable alarm	Selected
	Alarm notification	Notify when the state changed
	Notification target	State changes for the alarm
	Evaluate all data	Not selected
	Monitoring time range	Always
	Report alarm when the following damping condition is reached	Not selected
	occurrence(s) during	--
	interval(s)	--
Alarm Conditions	Record	Server Overview (PI_SERV)
	Field	Cache Hit %
	Abnormal condition	Cache Hit % < 85
	Warning condition	Cache Hit % < 95
Actions	E-mail	--
	Command	--
	SNMP	Abnormal, Warning, Normal

Legend:

--: The setting is always invalid.

Related report

Reports/SQL/Troubleshooting/Recent Past/Cache Usage (8.0)

CPU Usage

Overview

The CPU Usage alarm monitors the top 10 sessions that are currently using the largest numbers of CPU cycles.

This alarm cannot be used.

Main settings

Alarm properties in PFM - Web Console		Setting
Item	Detailed item	
Main Information	Product	SQL(8.0)
	Alarm message	CPU busy %CVS%
	Enable alarm	Selected
	Alarm notification	Notify when the state changed
	Notification target	State changes for the alarm
	Evaluate all data	Not selected
	Monitoring time range	Always
	Report alarm when the following damping condition is reached	Not selected
	occurrence(s) during	--
	interval(s)	--
Alarm Conditions	Record	Global Server Summary (PI)
	Field	CPU %
	Abnormal condition	CPU % > 90
	Warning condition	CPU % > 80
Actions	E-mail	--
	Command	--
	SNMP	Abnormal, Warning, Normal

Legend:

--: The setting is always invalid.

Related report

Reports/SQL/Troubleshooting/Real-Time/CPU Usage - Top 10 Sessions (8.0)

Database Space

Overview

The Database Space alarm monitors the space usage in each database in Microsoft SQL Server.

Main settings

Alarm properties in PFM - Web Console		Setting
Item	Detailed item	
Main Information	Product	SQL(8.0)
	Alarm message	Database %CVS% free
	Enable alarm	Selected
	Alarm notification	Notify when the state changed
	Notification target	State changes for the alarm
	Evaluate all data	Not selected
	Monitoring time range	Always
	Report alarm when the following damping condition is reached	Not selected
	occurrence(s) during	--
	interval(s)	--
Alarm Conditions	Record	Database Space Detail (PD_DS)
	Field	Free %
	Abnormal condition	Free % < 10
	Warning condition	Free % < 20
Actions	E-mail	--
	Command	--
	SNMP	Abnormal, Warning, Normal

Legend:

--: The setting is always invalid.

Related report

Reports/SQL/Status Reporting/Real-Time/Database Space Usage (7.0)

Log Space Usage

Overview

The Log Space Usage alarm monitors the top 10 databases that are consuming the largest amounts of log space.

Main settings

Alarm properties in PFM - Web Console		Setting
Item	Detailed item	
Main Information	Product	SQL(8.0)
	Alarm message	Log %CVS% used
	Enable alarm	Selected
	Alarm notification	Notify when the state changed
	Notification target	State changes for the alarm
	Evaluate all data	Not selected
	Monitoring time range	Always
	Report alarm when the following damping condition is reached	Not selected
	occurrence(s) during	--
	interval(s)	--
Alarm Conditions	Record	Transaction Log Overview (PI_TLOG)
	Field	Log Space Used %
	Abnormal condition	Log Space Used % > 90
	Warning condition	Log Space Used % > 80
Actions	E-mail	--
	Command	--
	SNMP	Abnormal, Warning, Normal

Legend:

--: The setting is always invalid.

Related report

Reports/SQL/Troubleshooting/Real-Time/Log Space Usage - Top 10 Databases

Network Error

Overview

The Network Error alarm monitors the impact of Microsoft SQL Server on the network.

Main settings

Alarm properties in PFM - Web Console		Setting
Item	Detailed item	
Main Information	Product	SQL(8.0)
	Alarm message	%CVS network errors detected
	Enable alarm	Selected
	Alarm notification	Notify when the state changed
	Notification target	State changes for the alarm
	Evaluate all data	Not selected
	Monitoring time range	Always
	Report alarm when the following damping condition is reached	Not selected
	occurrence(s) during	--
	interval(s)	--
Alarm Conditions	Record	Global Server Summary (PI)
	Field	Pkt Errors
	Abnormal condition	Pkt Errors > 2
	Warning condition	Pkt Errors > 0
Actions	E-mail	--
	Command	--
	SNMP	Abnormal, Warning, Normal

Legend:

--: The setting is always invalid.

Related report

Reports/SQL/Troubleshooting/Recent Past/Network Activity

Server Status

Overview

The Server Status alarm monitors the availability of the Microsoft SQL Server instance.

Main settings

Alarm properties in PFM - Web Console		Setting
Item	Detailed item	
Main Information	Product	SQL(8.0)
	Alarm message	Database server availability = %CVS
	Enable alarm	Selected
	Alarm notification	Notify when the state changed
	Notification target	State changes for the alarm
	Evaluate all data	Not selected
	Monitoring time range	Always
	Report alarm when the following damping condition is reached	Not selected
	occurrence(s) during	--
	interval(s)	--
Alarm Conditions	Record	Instance Availability (PD_IA)
	Field	Availability
	Abnormal condition	Availability = 0
	Warning condition	Availability = 0
Actions	E-mail	--
	Command	--
	SNMP	Abnormal, Warning, Normal

Legend:

--: The setting is always invalid.

Related report

Reports/SQL/Status Reporting/Real-Time/System Overview (8.0)

Format of report explanations

This section describes the format used to explain reports. This manual lists the reports in alphabetical order.

Report name

Indicates the name of a report in the monitoring template.

A report whose name contains (Multi-Agent) presents information about multiple instances.

A report whose name does not contain (Multi-Agent) presents information about a single instance.

Overview

Provides an overview of the information that can be displayed in the report.

Storage location

Indicates the storage location of the report.

Record

Indicates the record that contains the performance data used in the report. To display a historical report, you must specify information in advance in order to collect the record indicated in this column. Before displaying a report, display the agent properties in the Agents window of PFM - Web Console, and make sure that `Log = Yes` is set for this record. This setting is not needed to display a real-time report.

Fields

Provides a table that describes the fields used in the report.

Drilldown reports (report level)

Provides a table that lists other reports in the monitoring template that are related to this report. To display these drilldown reports, in the PFM - Web Console report window, select the name of a drilldown report from the **Drilldown report** drop-down list, and then click **Display Reports**. Note that some reports do not have any drilldown reports.

Drilldown reports (field level)

Provides a table that describes reports in the monitoring template that are associated with fields used in this report. To display this drilldown report, click the report graph displayed in the Report window of PFM - Web Console or the field name displayed on the bottom of the Report window. For a historical report, you can display the report in smaller time intervals by clicking the time displayed in blue inside the report. Note that some reports do not have any drilldown reports.

For details about a drilldown report, see the chapter explaining creation of reports for operation analysis in the JP1/Performance Management User's Guide.

Organization of report folders

The following shows the organization of the report folders for PFM - Agent for Microsoft SQL Server. Angle brackets enclose folder names.

```
<SQL>
+-- <Status Reporting>
|   +-- <Daily Trend>
|   |   +-- Cache Usage Trend(Multi-Agent) (8.0)
|   |   +-- Network Activity Trend
|   |   +-- Server CPU Trend
|   |   +-- Server Space Trend(Multi-Agent)
|   +-- <Real-Time>
|   |   +-- Database Space Usage (7.0)
|   |   +-- Server Configuration Status
|   |   +-- Server Space Usage (7.0)
|   |   +-- System Overview (8.0)
|   |   +-- <Drilldown Only>
|   |       +-- Database Space Usage Detail (7.0)
+-- <Monthly Trend>
|   +-- Cache Usage Trend(Multi-Agent) (8.0)
|   +-- Network Activity Trend
|   +-- Server CPU Trend
|   +-- Server Space Trend(Multi-Agent)
+-- <Troubleshooting>
+-- <Real-Time>
|   +-- Blocked Sessions (8.0)
|   +-- Blocking Locks (8.0)
|   +-- CPU Usage - Top 10 Sessions (8.0)
|   +-- Database Summary (8.0)
|   +-- Errorlog Overview
|   +-- Lock Overview (8.0)
|   +-- Lock Overview by Lock Type
|   +-- Lock Usage - Top 10 Sessions (8.0)
|   +-- Log Space Usage - Top 10 Databases
|   +-- Memory Usage - Top 10 Sessions (8.0)
|   +-- Physical I/O - Top 10 Sessions (8.0)
|   +-- Sessions (8.0)
|   +-- <Drilldown Only>
|   |   +-- Database Detail (8.0)
|   |   +-- Errorlog Detail
|   |   +-- Lock Detail (8.0)
|   |   +-- Session Detail (8.0)
+-- <Recent Past>
+-- Cache Usage (8.0)
+-- Log I/O Activity (8.0)
+-- Log I/O Activity 2 (8.0)
+-- Network Activity
+-- Pending I/O (8.0)
+-- Physical Write Activity (8.0)
+-- Physical Write Activity 2 (8.0)
```

The following describes each folder:

- Status Reporting folder

This folder contains reports for displaying daily information. Use this folder to check the overall status of the system. You can also display real-time reports in addition to historical reports.

- **Daily Trend folder**
This folder contains reports for displaying hourly information for the past 24 hours. Use the reports in this folder to check the daily status of the system.
- **Real-Time folder**
This folder contains real-time reports for checking the system status.
- **Monthly Trend folder**
This folder contains reports that display daily information for the past month. Use the reports in this folder to check monthly trends in the system.
- **Troubleshooting folder**
This folder contains reports for displaying information that is useful for resolving problems. In the event of a system problem, use the reports in this folder to check the cause of the problem.
 - **Real-Time folder**
This folder contains real-time reports for checking the current system status.
 - **Recent Past folder**
This folder contains historical reports for displaying minute-by-minute information for the past hour.

Additionally, these folders may contain the following folder under them:

- **Drilldown Only folder**
This folder contains reports that can be displayed as drilldown reports (field level). Use the reports in this folder to display the detailed information related to the fields of the report.

List of reports

The following table lists the reports defined in the monitoring template in alphabetical order.

Table 4–2: List of reports

Report name	Displayed information	Storage location
Blocked Sessions (8.0)	Information related to sessions that are waiting for lock release by other sessions	Reports/SQL/Troubleshooting/Real-Time/
Blocking Locks (8.0)	Information related to sessions that have locks that are blocking other sessions	Reports/SQL/Troubleshooting/Real-Time/
Cache Usage (8.0)	Cache statistics information for I/O buffers on a minute-by-minute basis over the past hour	Reports/SQL/Troubleshooting/Recent Past/
Cache Usage Trend(Multi-Agent) (8.0)	Cache statistics information for I/O buffers on an hour-by-hour basis over the past 24 hours	Reports/SQL/Status Reporting/Daily Trend/
Cache Usage Trend(Multi-Agent) (8.0)	Cache statistics information for I/O buffers on a day-by-day basis over the past month	Reports/SQL/Monthly Trend/
CPU Usage - Top 10 Sessions (8.0)	Information related to the top 10 sessions that are currently using the largest numbers of CPU cycles	Reports/SQL/Troubleshooting/Real-Time/
Database Detail (8.0)	Detailed information related to a particular database in Microsoft SQL Server	Reports/SQL/Troubleshooting/Real-Time/Drilldown Only/
Database Space Usage (7.0)	Information related to space usage in each database in Microsoft SQL Server	Reports/SQL/Status Reporting/Real-Time/
Database Space Usage Detail (7.0)	Detailed information related to space usage in each database in Microsoft SQL Server	Reports/SQL/Status Reporting/Real-Time/Drilldown Only/
Database Summary (8.0)	Detailed information related to the statuses of all databases in Microsoft SQL Server	Reports/SQL/Troubleshooting/Real-Time/
Errorlog Detail	Actual error messages recorded in the Microsoft SQL Server error log file	Reports/SQL/Troubleshooting/Real-Time/Drilldown Only/
Errorlog Overview	Overview of all errors that occurred in Microsoft SQL Server in the last interval	Reports/SQL/Troubleshooting/Real-Time/
Lock Detail (8.0)	Detailed information related to each lock	Reports/SQL/Troubleshooting/Real-Time/Drilldown Only/
Lock Overview (8.0)	Overview of locks in the entire instance (total number of database locks being maintained)	Reports/SQL/Troubleshooting/Real-Time/
Lock Overview by Lock Type	Overview of locks in the entire instance (total numbers of database locks being maintained by lock type)	Reports/SQL/Troubleshooting/Real-Time/
Lock Usage - Top 10 Sessions (8.0)	Information related to the top 10 sessions that currently have the largest numbers of locks on database objects	Reports/SQL/Troubleshooting/Real-Time/
Log I/O Activity (8.0)	Statistics information related to log entries by server on a minute-by-minute basis over the past hour	Reports/SQL/Troubleshooting/Recent Past/
Log I/O Activity 2 (8.0)	Statistics related to log entries created by the server for each minute over the past hour	Reports/SQL/Troubleshooting/Recent Past/

Report name	Displayed information	Storage location
Log Space Usage - Top 10 Databases	Information related to the top 10 databases that are currently consuming the largest amounts of log space	Reports/SQL/Troubleshooting/Real-Time/
Memory Usage - Top 10 Sessions (8.0)	Information related to the top 10 sessions that are currently using the largest amounts of memory	Reports/SQL/Troubleshooting/Real-Time/
Network Activity	Statistics information related to network activities on a minute-by-minute basis over the past hour	Reports/SQL/Troubleshooting/Recent Past/
Network Activity Trend	Statistics information related to network activities on an hour-by hour basis over the past 24 hours	Reports/SQL/Status Reporting/Daily Trend/
Network Activity Trend	Statistics information related to network activities on a day-by-day basis over the past month	Reports/SQL/Monthly Trend/
Pending I/O (8.0)	This report is reserved and cannot be used.	Reports/SQL/Troubleshooting/Recent Past/
Physical I/O - Top 10 Sessions (8.0)	Information related to the top 10 sessions that are currently executing the largest number of disk read/write operations	Reports/SQL/Troubleshooting/Real-Time/
Physical Write Activity (8.0)	Statistics information related to write activities on a minute-by-minute basis over the past hour	Reports/SQL/Troubleshooting/Recent Past/
Physical Write Activity 2 (8.0)	Statistics related to write activities for each minute over the past hour	Reports/SQL/Troubleshooting/Recent Past/
Server Configuration Status	Information related to environment setting parameter values for Microsoft SQL Server	Reports/SQL/Status Reporting/Real-Time/
Server CPU Trend	Statistics information on CPU usage on an hour-by-hour basis over the past 24 hours This report cannot display correct value.	Reports/SQL/Status Reporting/Daily Trend/
Server CPU Trend	Statistics information on CPU usage on a day-by-day basis over the past month This report cannot display correct value.	Reports/SQL/Monthly Trend/
Server Space Trend(Multi-Agent)	Statistics information on available space on an hour-by-hour basis over the past 24 hours	Reports/SQL/Status Reporting/Daily Trend/
Server Space Trend(Multi-Agent)	Statistics information on available space on a day-by-day basis over the past month	Reports/SQL/Monthly Trend/
Server Space Usage (7.0)	Statistics information related to the overall space usage in Microsoft SQL Server	Reports/SQL/Status Reporting/Real-Time/
Session Detail (8.0)	Detailed information related to resource usage in each session	Reports/SQL/Troubleshooting/Real-Time/Drilldown Only/
Sessions (8.0)	Information related to the statuses of all processes connected to Microsoft SQL Server	Reports/SQL/Troubleshooting/Real-Time/
System Overview (8.0)	Detailed information related to Microsoft SQL Server	Reports/SQL/Status Reporting/Real-Time/

Blocked Sessions (8.0)

Overview

The `Blocked Sessions (8.0)` report displays the information related to sessions that are waiting for lock release by other sessions. This report is displayed as a table. From the displayed report, you can display more detailed drilldown reports.

Note that the performance of a session that repeatedly waits for lock release declines.

Storage location

Reports/SQL/Troubleshooting/Real-Time/

Record

Lock Detail (PD_LD)

Fields

Field name	Description
Blocking Flag	This flag indicates whether or not the lock is a blocking lock. The following values are valid: 1 Blocking lock 0 Not a blocking lock
DB Name	Database name related to lock resource
Demand Flag	This flag indicates whether or not the lock is a request lock. The following values are valid: 1 Request lock 0 Not a request lock
Lock Type	Lock type (lock request mode and lock resource type)
Orphan Flag	This flag indicates whether or not the lock is an isolated lock. The following values are valid: 1 Isolated lock 0 Not an isolated lock
Program	Name of the application program that is requesting the lock
SPID	Process ID that is requesting the lock
Table	Table name if the lock resource is a table or row
User	Logon name of the user who issued the command

Drilldown reports (field level)

Report name	Description
Lock Detail (8.0)	Displays detailed information related to each lock. To display this report, click the Lock Type field.

Report name	Description
Session Detail (8.0)	Displays detailed information related to resource usage status in each session. To display this report, click the SPID field.

Blocking Locks (8.0)

Overview

The `Blocking Locks (8.0)` report displays information related to sessions that have locks that are blocking other sessions. This report is displayed as a table. From the displayed report, you can display more detailed drilldown reports.

Storage location

Reports/SQL/Troubleshooting/Real-Time/

Record

Lock Detail (PD_LD)

Fields

Field name	Description
Blocking Flag	This flag indicates whether or not the lock is a blocking lock. The following values are valid: 1 Blocking lock 0 Not a blocking lock
DB Name	Database name related to lock resource
Demand Flag	This flag indicates whether or not the lock is a request lock. The following values are valid: 1 Request lock 0 Not a request lock
Lock Type	Lock type (lock request mode and lock resource type)
Orphan Flag	This flag indicates whether or not the lock is an isolated lock. The following values are valid: 1 Isolated lock 0 Not an isolated lock
Program	Name of the application program that is requesting the lock
SPID	Process ID that is requesting the lock
Table	Table name if the lock resource is a table or row
User	Logon name of the user who issued the command

Drilldown reports (field level)

Report name	Description
Lock Detail (8.0)	Displays detailed information related to each lock. To display this report, click the Lock Type field.
Session Detail (8.0)	Displays detailed information related to resource usage status in each session. To display this report, click the SPID field.

Cache Usage (8.0)

Overview

The `Cache Usage (8.0)` report displays cache statistics information for I/O buffers on a minute-by-minute basis over the past hour. The information is displayed as a line graph. From the displayed report, you can display more detailed drilldown reports.

Storage location

Reports/SQL/Troubleshooting/Recent Past/

Record

Server Overview (PI_SERV)

Field

Field name	Description
Cache Hit %	Rate at which data pages were found inside the data cache

Drilldown reports (report level)

Report name	Description
Physical I/O - Top 10 Sessions (8.0)	Displays information related to the top 10 sessions that are currently executing the largest number of disk read/write operations

Cache Usage Trend(Multi-Agent) (8.0)

Overview

The Cache Usage Trend (Multi-Agent) (8.0) report displays cache statistics information for I/O buffers on an hour-by-hour basis over the past 24 hours. The information is displayed as a line graph. You can display this report for multiple instances of Microsoft SQL Server.

Storage location

Reports/SQL/Status Reporting/Daily Trend/

Record

Server Overview (PI_SERV)

Field

Field name	Description
Cache Hit %	Rate at which data pages were found inside the data cache

Cache Usage Trend(Multi-Agent) (8.0)

Overview

The Cache Usage Trend (Multi-Agent) (8.0) report displays cache statistics information for I/O buffers on a day-by-day basis over the past month. The information is displayed as a line graph. You can display this report for multiple instances of Microsoft SQL Server.

Storage location

Reports/SQL/Monthly Trend/

Record

Server Overview (PI_SERV)

Field

Field name	Description
Cache Hit %	Rate at which data pages were found inside the data cache

CPU Usage - Top 10 Sessions (8.0)

Overview

The CPU Usage - Top 10 Sessions (8.0) report displays information related to the top 10 sessions that are currently using the largest numbers of CPU cycles. This report is displayed as a bar graph. From the displayed report, you can display more detailed drilldown reports.

Storage location

Reports/SQL/Troubleshooting/Real-Time/

Record

Process Detail (PD_PDET)

Fields

Field name	Description
Command	Name of the command being executed
CPU %	CPU time being used by the process as a percentage of the CPU time being used by all database processes
Physical I/O	Cumulative number of times the process executed read/write operations to disks
Program	Application program name
SPID	Process ID
User	Logon name of the user who issued the command

Drilldown reports (field level)

Report name	Description
Session Detail (8.0)	Displays detailed information related to resource usage by each session. To display this report, click the CPU % field.

Database Detail (8.0)

Overview

The Database Detail (8.0) report displays detailed information related to a particular database on Microsoft SQL Server. This report is displayed as a list. This is a drilldown report.

Storage location

Reports/SQL/Troubleshooting/Real-Time/Drilldown Only/

Record

Database Detail (PD_DD)

Fields

Field name	Description
Availability	Database status. The following values are valid: Active Enabled. Process is running. Available Enabled. No process is running. NOT Available A crash or problem may have occurred during loading, and as a result the database cannot be opened or used in its current state. Restricted Database can be used only by its owner or a single user.
Blocked Processes	Number of blocked processes
Blocking Locks	Number of blocking locks
Create Date	Database creation date
DB Name	Database name
DB Owner	Database owner
DBID	Database ID
Demand Locks	Number of request locks
Exclusive Intent Locks	Number of exclusive intent locks
Exclusive Page Locks	Number of exclusive page locks
Exclusive Table Locks	Number of exclusive table locks
Last Dump Date	Last dump date for the transaction log
Locks	Total number of locks
Options	Database option
Other Processes	Number of other types of processes
Process Count	Total number of processes
Runnable Processes	Number of executable processes
Running Processes	Number of processes being executed

Field name	Description
Shared Intent Locks	Number of shared intent locks
Shared Page Locks	Number of shared page locks
Shared Table Locks	Number of shared table locks
Sleeping Processes	Number of sleeping processes
Update Page Locks	Number of update page locks
Version	<p>SQL Server version 2014 or earlier: Microsoft SQL Server version used for database creation</p> <p>SQL Server version 2016 or later: Value indicating the version of Microsoft SQL Server with operational compatibility</p>

Database Space Usage (7.0)

Overview

The Database Space Usage (7.0) report displays information related to space usage in each database in Microsoft SQL Server. This report is displayed as a pie graph. From the displayed report, you can display more detailed drilldown reports.

Storage location

Reports/SQL/Status Reporting/Real-Time/

Record

Database Space Detail (PD_DS)

Fields

Field name	Description
Data Mbytes	Size of database being used (megabytes)
DBID	Database ID
Free Mbytes	Size of free space (megabytes)
Index Mbytes	Size of index space being used (megabytes)
Unused Mbytes	Size of allocated but unused space (megabytes)

Drilldown reports (report level)

Report name	Description
Database Space Usage Detail (7.0)	Displays detailed information related to space usage in each database.

Drilldown reports (field level)

Report name	Description
Database Space Usage Detail (7.0)	Displays detailed information related to space usage in each database. To display this report, click the following fields: <ul style="list-style-type: none">• Data Mbytes• Free Mbytes• Index Mbytes• Unused Mbytes

Database Space Usage Detail (7.0)

Overview

The Database Space Usage Detail (7.0) report displays detailed information related to space usage in each database. This report is displayed as a list. This is a drilldown report.

Storage location

Reports/SQL/Status Reporting/Real-Time/Drilldown Only/

Record

Database Space Detail (PD_DS)

Fields

Field name	Description
Data Mbytes	Size of database being used (megabytes)
DB Name	Database name
DB Size	Database size in megabytes
DBID	Database ID
Free Mbytes	Size of free space (megabytes)
Index Mbytes	Size of index space being used (megabytes)
Log Mbytes	Size of log space being used (megabytes)
Rsvd Mbytes	Size of allocated space (megabytes)
Unused Mbytes	Size of allocated but unused space (megabytes)

Database Summary (8.0)

Overview

The Database Summary (8.0) report displays detailed information related to the statuses of all databases in Microsoft SQL Server. This report is displayed as a table. From the displayed report, you can display more detailed drilldown reports.

Storage location

Reports/SQL/Troubleshooting/Real-Time/

Record

Database Detail (PD_DD)

Fields

Field name	Description
Availability	Database status. The following values are valid: Active Enabled. Process is running. Available Enabled. No process is running. NOT Available A crash or problem may have occurred during loading, and as a result the database cannot be opened or used in its current state. Restricted Database can be used only by its owner or a single user.
Blocked Processes	Number of blocked processes
Blocking Locks	Number of blocking locks
Create Date	Database creation date
DB Name	Database name
DB Owner	Database owner
DBID	Database ID
Last Dump Date	Last dump date for the transaction log
Locks	Total number of locks
Process Count	Total number of processes
Version	SQL Server version 2014 or earlier: Microsoft SQL Server version used for database creation SQL Server version 2016 or later: Value indicating the version of SQL Server with operational compatibility

Drilldown reports (field level)

Report name	Description
Blocked Sessions (8.0)	Displays the information related to sessions that are waiting for lock release by other sessions. To display this report, click the Blocked Processes field.
Blocking Locks (8.0)	Displays information related to sessions that have locks that are blocking other sessions. To display this report, click the Blocking Locks field.
Database Detail (8.0)	Displays detailed information related to a particular database on Microsoft SQL Server. To display this report, click the DB Name field.
Sessions (8.0)	Displays information related to the statuses of all processes connected to Microsoft SQL Server. To display this report, click the Process Count field.

Errorlog Detail

Overview

The Errorlog Detail report displays the actual error messages recorded in the Microsoft SQL Server error log file. This report is displayed as a table. This report is a drilldown report.

Storage Location

Reports/SQL/Troubleshooting/Real-Time/Drilldown Only/

Record

Errorlog Error Detail (PD_EE)

Fields

Field name	Description
Error #	Error number
Error Time	Error date and time
Message	Error message text
Severity	Error message severity level
State	Error message status code

Errorlog Overview

Overview

The Errorlog Overview report displays the overview of all errors that occurred in Microsoft SQL Server in the last interval. This report is displayed as a list. From the displayed report, you can display more detailed drilldown reports.

Storage Location

Reports/SQL/Troubleshooting/Real-Time/

Record

Errorlog Summary Detail (PD_ES)

Fields

Field name	Description
Errorlog Errors	Total number of errors recorded in the error log during the interval
Fatal Errors	Total number of fatal errors that occurred during the interval
Internal Errors	Total number of internal errors that occurred during the interval
Last Error Time	Time Date and time of the last error
Resource Errors	Total number of resource errors that occurred during the interval

Drilldown reports (report level)

Report name	Description
Errorlog Detail	Displays the actual error messages recorded in the Microsoft SQL Server error log file.

Lock Detail (8.0)

Overview

The *Lock Detail (8.0)* report displays detailed information related to each lock. This report is displayed as a list. It is a drilldown report. From the displayed drilldown report, you can display more detailed drilldown reports.

Storage location

Reports/SQL/Troubleshooting/Real-Time/Drilldown Only/

Record

Lock Detail (PD_LD)

Fields

Field name	Description
Blocking Flag	This flag indicates whether or not the lock is a blocking lock. The following values are valid: 1 Blocking lock 0 Not a blocking lock
DB Name	Database name related to lock resource
DBID	Database ID related to lock resource
Demand Flag	This flag indicates whether or not the lock is a request lock. The following values are valid: 1 Request lock 0 Not a request lock
Lock Type	Lock type (lock request mode and lock resource type)
Orphan Flag	This flag indicates whether or not the lock is an isolated lock. The following values are valid: 1 Isolated lock 0 Not an isolated lock
Page #	Number of pages allocated to lock resource
Program	Name of the application program that is requesting the lock
SPID	Process ID that is requesting the lock
Table	Table name if the lock resource is a table or row
User	Logon name of the user who issued the command

Drilldown reports (field level)

Report name	Description
Session Detail (8.0)	Displays detailed information related to resource usage in each session. To display this report, click the SPID field.

Lock Overview (8.0)

Overview

The **Lock Overview (8.0)** report displays the overview of locks in the entire instance as the total number of database locks being maintained. This report is displayed as a list. From the displayed report, you can display more detailed drilldown reports.

Storage location

Reports/SQL/Troubleshooting/Real-Time/

Record

Server Locks Detail (PD_LOCK)

Fields

Field name	Description
Total Blocking Locks	Number of locks that are blocking other processes
Total Exclusive Locks	Total number of exclusive locks
Total Extent Locks	Total number of extent locks
Total Intent Locks	Total number of intent locks
Total Locks	Total number of locks being used by Microsoft SQL Server
Total Page Locks	Total number of page locks
Total Shared Locks	Total number of shared locks
Total Table Locks	Total number of table locks
Users Blocked	Number of users who are blocked by other users

Drilldown reports (report level)

Report name	Description
Lock Overview by Lock Type	Displays the overview of locks in the entire instance as the total numbers of database locks being maintained by lock type.

Drilldown reports (field level)

Report name	Description
Blocked Sessions (8.0)	Displays the information related to sessions that are waiting for lock release by other sessions. To display this report, click the Users Blocked field.
Blocking Locks (8.0)	Displays information related to sessions that have locks that are blocking other sessions. To display this report, click the Total Blocking Locks field.

Lock Overview by Lock Type

Overview

The Lock Overview by Lock Type report displays the overview of locks in the entire instance as the total number of database locks being maintained by lock type. This report is displayed as a list.

Storage location

Reports/SQL/Troubleshooting/Real-Time/

Record

Server Locks Detail (PD_LOCK)

Fields

Field name	Description
Exclusive Extent Locks	Number of exclusive extent locks
Exclusive Intent Locks	Number of exclusive intent locks
Exclusive Page Locks	Number of exclusive page locks
Exclusive Table Locks	Number of exclusive table locks
Shared Intent Locks	Number of shared intent locks
Shared Page Locks	Number of shared page locks
Shared Table Locks	Number of shared table locks
Update Extent Locks	Number of update extent locks
Update Page Locks	Number of update page locks

Lock Usage - Top 10 Sessions (8.0)

Overview

The *Lock Usage - Top 10 Sessions (8.0)* report displays information related to the top 10 sessions that currently have the largest numbers of locks on database objects. This report is displayed as a bar graph. From the displayed report, you can display more detailed drilldown reports.

Storage location

Reports/SQL/Troubleshooting/Real-Time/

Record

Process Detail (PD_PDET)

Fields

Field name	Description
Blocked Processes	Number of processes blocked by the process
DB Name	Name of the database being used by the process at the time of record acquisition
Locks	Number of locks being requested by the process at the time of record acquisition
Program	Application program name
SPID	Process ID
User	Logon name of the user who issued the command

Drilldown reports (field level)

Report name	Description
Session Detail (8.0)	Displays detailed information related to resource usage in each session. To display this report, click the Locks field.

Log I/O Activity (8.0)

Overview

The Log I/O Activity (8.0) report displays statistics information related to log entries by server on a minute-by-minute basis over the past hour. The information is displayed as a line graph.

Storage location

Reports/SQL/Troubleshooting/Recent Past/

Record

Server Overview (PI_SERV)

Field

Field name	Description
Log Writes/sec	Total number of log pages physically written onto a disk

Log I/O Activity 2 (8.0)

Overview

The Log I/O Activity 2 (8.0) report displays statistics related to log entries by server for each minute basis over the past hour. This report is displayed as a line graph.

Storage location

Reports/SQL/Troubleshooting/Recent Past/

Record

Server Overview 2 (PI_SRV2)

Field

Field name	Description
Log Writes/sec	The number of log pages written per second to a physical disk over an interval.

Log Space Usage - Top 10 Databases

Overview

The Log Space Usage - Top 10 Databases report displays information related to the top 10 databases that are currently consuming the largest amounts of log space. This report is displayed as a bar graph.

Storage location

Reports/SQL/Troubleshooting/Real-Time/

Record

Transaction Log Overview (PI_TLOG)

Fields

Field name	Description
DB Name	Database name
Log Size Mbytes	Size of space allocated to transaction log (megabytes)

Memory Usage - Top 10 Sessions (8.0)

Overview

The *Memory Usage - Top 10 Sessions (8.0)* report displays information related to the top 10 sessions that are currently using the largest amounts of memory. This report is displayed as a bar graph. From the displayed report, you can display more detailed drilldown reports.

Storage location

Reports/SQL/Troubleshooting/Real-Time/

Record

Process Detail (PD_PDET)

Fields

Field name	Description
Mem Usage	SQL Server version 2014 or earlier: Number of procedure cache pages allocated to the process (1 page equals 8 kilobytes) SQL Server version 2016 or later: Number of pages of memory used in the process
Program	Application program name

Drilldown reports (field level)

Report name	Description
Session Detail (8.0)	Displays detailed information related to resource usage in each session. To display this report, click the Mem Usage field.

Network Activity

Overview

The `Network Activity` report displays statistics information related to network activities on a minute-by-minute basis over the past hour. The information is displayed as a line graph.

Storage location

Reports/SQL/Troubleshooting/Recent Past/

Record

Global Server Summary (PI)

Fields

Field name	Description
Pkt Errors	Number of packet errors
Pkts Rcvd	Number of packets received
Pkts Sent	Number of packets sent

Network Activity Trend

Overview

The `Network Activity Trend` report displays statistics information related to network activities on an hour-by-hour basis over the past 24 hours. The information is displayed as a line graph.

Storage location

Reports/SQL/Status Reporting/Daily Trend/

Record

Global Server Summary (PI)

Fields

Field name	Description
Pkt Errors	Number of packet errors
Pkts Rcvd	Number of packets received
Pkts Sent	Number of packets sent

Network Activity Trend

Overview

The `Network Activity Trend` report displays statistics information related to network activities on a day-by-day basis over the past month. The information is displayed as a line graph.

Storage location

Reports/SQL/Monthly Trend/

Record

Global Server Summary (PI)

Fields

Field name	Description
Pkt Errors	Number of packet errors
Pkts Rcvd	Number of packets received
Pkts Sent	Number of packets sent

Pending I/O (8.0)

Overview

The Pending I/O (8.0) report is reserved and cannot be used.

Storage location

Reports/SQL/Troubleshooting/Recent Past/

Physical I/O - Top 10 Sessions (8.0)

Overview

The *Physical I/O - Top 10 Sessions (8.0)* report displays information related to the top 10 sessions that are currently executing the largest number of disk read/write operations. This report is displayed as a bar graph. From the displayed report, you can display more detailed drilldown reports.

Storage location

Reports/SQL/Troubleshooting/Real-Time/

Record

Process Detail (PD_PDET)

Fields

Field name	Description
Physical I/O	Cumulative number of times the process executed read/write operations to disks
Program	Application program name

Drilldown reports (field level)

Report name	Description
Session Detail (8.0)	Displays detailed information related to resource usage by each session. To display this report, click the Physical I/O field.

Physical Write Activity (8.0)

Overview

The `Physical Write Activity (8.0)` report displays statistics information related to write activities on a minute-by-minute basis over the past hour. The information is displayed as a line graph.

You can use this report to check the statistics on physical writing and delay writing operations.

Storage location

Reports/SQL/Troubleshooting/Recent Past/

Record

Server Overview (PI_SERV)

Fields

Field name	Description
Lazy Writes/sec	Total number of pages flushed by Lazy Writer to a disk (1 page equals 8 kilobytes)
Page Writes/sec	Total number of physical page write operations

Physical Write Activity 2 (8.0)

Overview

The Physical Write Activity 2 (8.0) report displays statistics related to write activities for each minute over the past hour. This report is displayed as a line graph.

You can use this report to view the statistics on physical and delayed writing.

Storage location

Reports/SQL/Troubleshooting/Recent Past/

Record

Server Overview 2 (PI_SRV2)

Fields

Field name	Description
Lazy Writes/sec	Number of pages (where a page is 8 KB) flushed per second to a disk by Lazy Writer over an interval
Page Writes/sec	Number of times physical page writes were performed per second over an interval

Server Configuration Status

Overview

The `Server Configuration Status` report displays information related to environment setting parameter values for Microsoft SQL Server. This report is displayed as a table.

Storage location

Reports/SQL/Status Reporting/Real-Time/

Record

Config Detail (PD_CD)

Fields

Field name	Description
Config Value	Environment setting option value
Current Run Value	Environment setting option value (execution value during data collection)
Max Value	Maximum value of environment setting option
Min Value	Minimum value of environment setting option
Name	Name of environment setting option

Server CPU Trend

Overview

The *Server CPU Status* report displays statistics information on CPU usage on an hour-by-hour basis over the past 24 hours. The information is displayed as a line graph.

This report cannot display correct value.

Storage location

Reports/SQL/Status Reporting/Daily Trend/

Record

Global Server Summary (PI)

Fields

Field name	Description
CPU %	Percentage of time CPU is busy
I/O %	Percentage of CPU time spent for I/O
Idle %	Percentage of time CPU is idle

Server CPU Trend

Overview

The `Server CPU Trend` report displays statistics information on CPU usage on a day-by-day basis over the past month. The information is displayed as a line graph.

This report cannot display correct value.

Storage location

Reports/SQL/Monthly Trend/

Record

Global Server Summary (PI)

Fields

Field name	Description
CPU %	Percentage of time CPU is busy
I/O %	Percentage of CPU time spent for I/O
Idle %	Percentage of time CPU is idle

Server Space Trend(Multi-Agent)

Overview

The Server Space Trend (Multi-Agent) report displays statistics information on available space on an hour-by-hour basis over the past 24 hours. The information is displayed as a line graph. You can display this report for multiple instances of Microsoft SQL Server.

Storage location

Reports/SQL/Status Reporting/Daily Trend/

Record

Server Space Interval (PI_SI)

Field

Field name	Description
Free %	Percentage of free space in the entire database area

Server Space Trend(Multi-Agent)

Overview

The `Server Space Trend (Multi-Agent)` report displays statistics information on available space on a day-by-day basis over the past month. The information is displayed as a line graph. You can display this report for multiple instances of Microsoft SQL Server.

Storage location

Reports/SQL/Monthly Trend/

Record

Server Space Interval (PI_SI)

Field

Field name	Description
Free %	Percentage of free space in the entire database area

Server Space Usage (7.0)

Overview

The *Server Space Usage (7.0)* report displays statistics information related to the overall space usage in Microsoft SQL Server. This report is displayed as a pie graph and a list. From the displayed report, you can display more detailed drilldown reports.

Storage location

Reports/SQL/Status Reporting/Real-Time/

Record

Server Space Detail (PD_SS)

Fields

Field name	Description
Data Mbytes	Size of data space being used (megabytes)
DB Size	Size of the entire database (megabytes)
Free Mbytes	Size of free space (megabytes)
Index Mbytes	Size of index space being used (megabytes)
Log Mbytes	Size of log space being used (megabytes)
Rsvd Mbytes	Size of allocated space (megabytes)
Unused Mbytes	Size of allocated but unused space (megabytes)

Drilldown reports (report level)

Report name	Description
Database Space Usage (7.0)	Displays information related to space usage in each database in Microsoft SQL Server.

Session Detail (8.0)

Overview

The `Session Detail (8.0)` report displays detailed information related to resource usage in each session. This report is displayed as a list. It is a drilldown report. From the displayed drilldown report, you can display more detailed drilldown reports.

Storage location

Reports/SQL/Troubleshooting/Real-Time/Drilldown Only/

Record

Process Detail (PD_PDET)

Fields

Field name	Description
Blocked Processes	Number of processes blocked by the process
Blocking Process	Process ID of a blocking process, if any
Command	Name of the command executed
CPU %	CPU time being used by the process, as a percentage of the CPU time being used by all database processes
DB Name	Name of the database being used by the process at the time of record acquisition
DBID	Database ID being used by the process at the time of record acquisition
GID	This field is reserved and cannot be used.
Host	Host computer name
Host PID	Host process ID
Locks	Number of locks being requested by the process at the time of record acquisition
Mem Usage	SQL Server version 2014 or earlier: Number of procedure cache pages allocated to the process (1 page equals 8 kilobytes) SQL Server version 2016 or later: Number of pages of memory used in the process
Physical I/O	Cumulative number of times the process executed read/write operations to disks
Program	Application program name
SPID	Process ID
Status	Process status
UID	SQL Server version 2014 or earlier: User ID of the user who executed the command SQL Server version 2016 or later: This field cannot display correct value.
User	Logon name of the user who issued the command

Drilldown reports (field level)

Report name	Description
Blocked Sessions (8.0)	Displays the information related to sessions that are waiting for lock release by other sessions. To display this report, click the Blocked Processes field.
Database Detail (8.0)	Displays detailed information related to a particular database on Microsoft SQL Server. To display this report, click the DB Name field.
Lock Detail (8.0)	Displays detailed information related to each lock. To display this report, click the Blocking Process field.

Sessions (8.0)

Overview

The `Sessions (8.0)` report displays information related to the statuses of all processes connected to Microsoft SQL Server. This report is displayed as a table. From the displayed report, you can display more detailed drilldown reports.

Storage location

Reports/SQL/Troubleshooting/Real-Time/

Record

Process Detail (PD_PDET)

Fields

Field name	Description
Blocked Processes	Number of processes blocked by the process
Blocking Process	Process ID of a blocking process, if any
DB Name	Name of the database being used by the process at the time of record acquisition
DBID	Database ID being used by the process at the time of record acquisition
Mem Usage	SQL Server version 2014 or earlier: Number of procedure cache pages allocated to the process (1 page equals 8 kilobytes) SQL Server version 2016 or later: Number of pages of memory used in the process
Program	Application program name
SPID	Process ID
User	Logon name of the user who issued the command

Drilldown reports (field level)

Report name	Description
Database Detail (8.0)	Displays detailed information related to a particular database on Microsoft SQL Server. To display this report, click the DB Name field.
Session Detail (8.0)	Displays detailed information related to resource usage by each session. To display this report, click one of the following fields: <ul style="list-style-type: none">Blocking ProcessSPID

System Overview (8.0)

Overview

The *System Overview (8.0)* report displays detailed information related to Microsoft SQL Server. The information is displayed as a list and as a line graph. From the displayed report, you can display more detailed drilldown reports.

Storage location

Reports/SQL/Status Reporting/Real-Time/

Record

Server Detail (PD)

Fields

Field name	Description
Blocked Processes	Number of blocked processes
Blocking Locks	Number of blocking locks
Boot Time	Server boot date
Cache Hit %	Rate at which data pages were found inside the data cache during an interval
Conns	Number of client connections
CPU %	Percentage of time CPU is busy This field cannot display correct value.
Database Count	Number of databases
Host OS	OS that is running Microsoft SQL Server
Host Type	Type of machine on which Microsoft SQL Server is running. Either of the following values is displayed: <ul style="list-style-type: none">• For the 32-bit and 64-bit (IPF) versions of Microsoft SQL Server: Intel• For the 64-bit version of Microsoft SQL Server (x64): X64
I/O %	Percentage of CPU time spent for I/O This field cannot display correct value.
Idle %	Percentage of time CPU is idle This field cannot display correct value.
Locks	Total number of locks
Pkt Errors	Number of packet errors
Pkts Rcvd	Number of packets received
Pkts Sent	Number of packets sent
Server Name	Name of the machine on which Microsoft SQL Server is running
Total Errors	Number of disk errors
Total Reads	Number of disk read operations
Total Writes	Number of disk write operations

Field name	Description
Version	Microsoft SQL Server version

Drilldown reports (report level)

Report name	Description
Database Space Usage (7.0)	Displays information related to space usage in each database in Microsoft SQL Server.
Lock Overview (8.0)	Displays the overview of locks in the entire instance as a total number of database locks being maintained.
Log Space Usage - Top 10 Databases	Displays information related to the top 10 databases that are currently consuming the largest amounts of log space.
Server Configuration Status	Displays information related to environment setting parameter values for Microsoft SQL Server.
Server Space Usage (7.0)	Displays statistics information related to the overall space usage in Microsoft SQL Server.

Drilldown reports (field level)

Report name	Description
Blocked Sessions (8.0)	Displays the information related to sessions that are waiting for lock release by other sessions. To display this report, click the Blocked Processes field.
Blocking Locks (8.0)	Displays information related to sessions that have locks that are blocking other sessions. To display this report, click the Blocking Locks field.
CPU Usage - Top 10 Sessions (8.0)	Displays information related to the top 10 sessions that are currently using the largest numbers of CPU cycles. To display this report, click the CPU % field.
Database Summary (8.0)	Displays detailed information related to the statuses of all databases in Microsoft SQL Server. To display this report, click the Database Count field.
Errorlog Overview	Displays information related to the top 10 sessions that currently have the largest numbers of locks on database objects. To display this report, click the Locks field.
Lock Usage - Top 10 Sessions (8.0)	Displays information related to the top 10 sessions that are currently using the largest amounts of memory. To display this report, click the Cache Hit % field.
Memory Usage - Top 10 Sessions (8.0)	Displays statistics information related to network activities on a minute-by-minute basis over the past hour. To display this report, click one of the following fields: <ul style="list-style-type: none"> • Pkt Errors • Pkts Rcvd • Pkts Sent
Network Activity	Displays information related to the top 10 sessions that are currently executing the largest number of disk read/write operations. To display this report, click the I/O % field.
Physical I/O - Top 10 Sessions (8.0)	Displays the information related to sessions that are waiting for lock release by other sessions. To display this report, click the Blocked Processes field.

5

Records

This chapter describes the records for PFM - Agent for Microsoft SQL Server. For details about collecting performance data for each type of record, see the chapter on Performance Management functionality in the *JP1/Performance Management Planning and Configuration Guide* or the chapter on management of operation monitoring data in the *JP1/Performance Management User's Guide*.

Data model

Each PFM - Agent for Microsoft SQL Server records and fields are referred to collectively as a *data model*. There is a specific version number for each PFM - Agent for Microsoft SQL Server and its data model.

For details about data model versions of PFM - Agent for Microsoft SQL Server, see [H. Version Compatibility](#).

To check the data model version of each PFM - Agent for Microsoft SQL Server, use the Properties window in PFM - Web Console. To display the Properties window, click the agent icon on the **Agents** page in PFM - Web Console, and then click the **Properties** method.

For details about data models, see the chapter on Performance Management functionality in the *JPI/Performance Management Planning and Configuration Guide*.

Format of record explanations

This chapter describes the records for PFM - Agent for Microsoft SQL Server in alphabetical order. The explanation of each record consists of the following subsections:

Function

Provides an overview of the performance data that is stored in the record and includes important information that should be noted.

Default and changeable values

Consists of a table of the default values for the performance data under the collection conditions that are defined for the record, and indicates whether or not the values can be changed by the user. The table below lists and describes the items that appear in the Default and changeable values subsections. For details about each item in the table, see the chapter on management of operation monitoring data in the *JP1/Performance Management User's Guide*.

Table 5–1: Default and changeable values

Item	Default value	Changeable
Collection Interval	Performance data collection interval (in seconds)	Y: Changeable N: Not changeable
Collection Offset ^{#1}	Offset value for starting performance data collection (in seconds). For details about offset values, see the chapter on management of operation monitoring data in the <i>JP1/Performance Management User's Guide</i> . For collection start time for the performance data, see the chapter on the Performance Management functionality in the <i>JP1/Performance Management Planning and Configuration Guide</i> .	
Log	Whether or not collected performance data is stored in the Store database: Yes: Store (however, if <code>Collection Interval=0</code> is set, collected performance data is not stored). No: Do not store.	
LOGIF	Conditions for storing collected performance data in the Store database	
Over 10 Sec Collection Time ^{#2}	Whether a certain system configuration can cause record collection to take 10 seconds or longer. Yes: Record collection might take 10 seconds or longer. No: Record collection does not take 10 seconds.	

#1

The range of values is from 0 to 32,767 (inclusive) seconds (within the value range specified for Collection Interval). This is used to distribute the collection processing workload because data collection is concentrated when multiple data items are collected. The data collection time that is recorded is the same as for the Collection Interval regardless of the value of Collection Offset.

If you change the value of Collection Offset, you should take into account the collection processing workload.

#2

This property is displayed if the collection of historical data is prioritized over the display processing of real-time reports. For details, see the chapter on troubleshooting in the *JP1/Performance Management User's Guide*.

ODBC key fields

These fields display the primary keys that are necessary to use the data retrieved from records stored in the Store database on either PFM - Manager or PFM - Base. Some ODBC key fields are common to all records, and some are specific to

each record. This section presents the ODBC key fields that are specific to each record. Only the multi-instance records have specific ODBC key fields.

For details about the ODBC key fields common to all records, see *List of ODBC key fields* in this chapter.

Lifetime

Indicates the period during which consistency is guaranteed for the performance data that is collected in the record. For details about lifetimes, see the chapter on Performance Management functionality in the *JPI/Performance Management Planning and Configuration Guide*.

Record size

Indicates the amount of performance data that can be collected and stored in each record at one time.

Fields

Provides a table that describes the fields of each record. The table contains the following items:

- PFM - View name(PFM - Manager name)
 - PFM - View name
Indicates the field name that is displayed with PFM - Web Console (PFM - View name).
 - PFM - Manager name
Field name (PFM - Manager name) to be specified in SQL statements when SQL statements are used from PFM - Manager to access the field data stored in the Store database.
You specify the record ID at the beginning of an SQL statement. For example, to specify the Config Value (CONFIG_VALUE) field of the Config Detail (PD_CD) record, specify PD_CD_CONFIG_VALUE.

- Description
Explanation of the performance data that is stored in the field.
Notes #1 and #2 in the table indicate the following:

#1

A value in this field is the latest monitored value that the OS returns at the time of data collection.

#2

When this field is displayed in the historical report, the PFM - View name (Total) field is added.

For each field, the following methods of calculating performance data are available:

- Calculations (such as averages or percentages) based on data collected in the current and previous intervals.
- Calculations based on data collected in the current interval only. This data includes the values accumulated internally by the OS (the data marked as #1 in the table).
- Calculations based on data in other fields (See Data source in the table of each record's fields.)

Unless otherwise noted, the value in each field is an unprocessed value that was collected at a specified data collection interval.

The following types of values are displayed in a historical report when records of the PI record type are summarized and displayed while the report interval setting is not "minute":

- The average value for the summarized interval
- The last collected value
- The sum total of values
- The minimum value

- The maximum value

Unless otherwise noted, the value in each field displays the average for the summarized interval.

- Summary

The summarization method (Summary rules) used by Agent Store when summarizing data. For details, see *Summary rules* in this chapter.

- Format

Data type of the field value, such as `double`. For details about the data types, see *List of data types* in this chapter.

- Delta

In contrast to the data collected as the cumulative value, the so-called *delta* is the data that indicates the changed amount. For details about delta, see *Field values* in this chapter.

- Data source

Method used to obtain the field value or the source of the data. For details about field values, see *Field values* in this chapter.

List of ODBC key fields

Some ODBC key fields are common to all records, and some are specific to each record. This section presents the ODBC key fields common to all records. The ODBC key fields are necessary to use the data retrieved from records stored in the Store database on PFM - Manager.

The table below lists the ODBC key fields common to all records. For details about the ODBC key fields specific to each record, see the details of each record.

Table 5–2: List of ODBC key fields common to all records

ODBC key field	ODBC format	Data	Description
<i>record-ID</i> _DATE	SQL_INTEGER	Internal	Key in the record that indicates the record creation date
<i>record-ID</i> _DATETIME	SQL_INTEGER	Internal	Combination of the <i>record-ID</i> _DATE and <i>record-ID</i> _TIME fields
<i>record-ID</i> _DEVICEID	SQL_VARCHAR	Internal	<i>instance-name</i> [<i>host-name</i>]
<i>record-ID</i> _DRAWER_TYPE	SQL_VARCHAR	Internal	Type. Valid values are as follows: m: Minute H: Hour D: Day W: Week M: Month Y: Year
<i>record-ID</i> _PROD_INST	SQL_VARCHAR	Internal	Instance name of PFM - Agent for Microsoft SQL Server
<i>record-ID</i> _PRODID	SQL_VARCHAR	Internal	Product ID of PFM - Agent for Microsoft SQL Server
<i>record-ID</i> _RECORD_TYPE	SQL_VARCHAR	Internal	Identifier indicating the record type (4 bytes)
<i>record-ID</i> _TIME	SQL_INTEGER	Internal	Record creation time (Greenwich mean time (GMT))

Summary rules

Summary records contain collected data that is summarized at set intervals (by minute, hour, day, week, month, or year) and saved in the Store database. Data is summarized according to the operation defined for the particular field. These operation definitions are called *summary rules*.

A field called an *additional field* might be added to the Store database when data is summarized. Whether an additional field is generated, and the type of the field if generated, depend on the summary rule. Some additional fields are displayed as record fields in PFM - Web Console. These additional fields, which are displayed in PFM - Web Console, can be used in viewing historical reports.

The fields referred to in the record descriptions in this chapter are called *record-specific fields*, to distinguish them from additional fields generated when data is summarized.

Additional fields have the following field names:

- Additional field contained in the Store database
Manager name of the record-specific field, plus a suffix
- Additional field displayed in PFM - Web Console
View name of the record-specific field, plus a suffix

The following table shows the suffix added to the Manager name, the suffix added to the corresponding View name, and the data stored in that field.

Table 5–3: List of suffixes in additional field names

Suffix added to the Manager name	Suffix added to the View name	Field data
_TOTAL	(Total)	Sum of the field values in all records in the summary period
_TOTAL_SEC	(Total)	Sum of the values of the field in the records collected within the summarization period (when the data type of the field is utime)
_COUNT	--	Number of records collected in the summary period
_HI	(Max)	Largest field value in the records in the summary period
_LO	(Min)	Smallest field value in the records in the summary period
_OV	(OV)	The number of times that the sum of the values of the field in the records collected within the summarization period overflowed. The value is determined by using the following formula: $\frac{\text{(sum-of-the-field-values)}}{\text{(maximum-value-for-the-existing-field + 1)}}$ Note: Numbers after the decimal point are discarded.

Legend:

--: No additional field.

The table below lists the summary rules.

Table 5–4: List of summary rules

Summary rule name	Summary rules
COPY	Stores the actual field value of the most recent record in the summary period.
AVG	Stores the average field value of all field values in the summary period.

Summary rule name	Summary rules
AVG	<p>The average value is calculated using the following expression:</p> <div style="border: 1px solid black; padding: 5px; margin: 5px 0;"> $(total-sum-of-the-field-values) / (number-of-collected-records)$ </div> <p>Additional field (Store database)</p> <ul style="list-style-type: none"> • <code>_TOTAL</code> • <code>_TOTAL_SEC</code> (when the data type of the field is utime) • <code>_COUNT</code> <p>Additional field (PFM - Web Console)^{#1, #2}</p> <ul style="list-style-type: none"> • (Total)
ADD	Sum of the field values in all records in the summary period
ADDBI	<p>The lower bytes of the sum of the field values collected within the summarization period are stored in the Store database. The maximum value is extended to 256 times the maximum value in the ADD rule.</p> <p>The value is determined by using the following formula:(sum-of-the-field-values) % (maximum-value-for-the-existing-field) In the above formula, % indicates that there is a remainder.</p> <p>Added field (Store database):</p> <ul style="list-style-type: none"> • <code>_OV</code> <p>Added field (PFM - Web Console) :</p> <ul style="list-style-type: none"> • (OV)
HI	Largest field value in the records in the summary period
LO	Smallest field value in the records in the summary period
--	No summarization

#1

For utime type fields whose Manager names contain the character string `_AVG`, the (Total) fields that are added in Performance Reporter cannot be used for historical reports.

#2

For fields whose Manager names contain any of the following character strings, the (Total) fields that are added in Performance Reporter cannot be used for historical reports:

`_PER_`, `PCT`, `PERCENT`, `_AVG`, `_RATE_TOTAL`

List of data types

The following table lists the data types for field values and the corresponding C and C++ data types. The values in the *Format* column of the record field tables have the types shown below in the *Field* column under *Data type*.

Table 5–5: List of summary rules

Data type		Byte	Description
Field	C and C++		
char(n)	char()	Number in parentheses	Character data of <i>n</i> bytes.
double	double	8	Numeric value (1.7E±308 (15 digits))
long	long	4	Numeric value (-2,147,483,648 to 2,147,483,647)
string(n)	char[]	Number in parentheses	Character string of <i>n</i> bytes. <ul style="list-style-type: none"> Japanese Windows: Shift-JIS characters can be set. Simplified-Chinese Windows: GB18030 characters can be set[#]. Other Windows: Only 7-bit ASCII characters can be set. The last character is null.
time_t	unsigned long	4	Numeric value (0 to 4,294,967,295)
timeval	Structure	8	Numeric value (first 4 bytes are seconds, next 4 bytes are microseconds)
ulong	unsigned long	4	Numeric value (0 to 4,294,967,295)
utime	Structure	8	Numeric value (first 4 bytes are seconds, next 4 bytes are microseconds)
word	unsigned short	2	Numeric value (0 to 65,535)
(Not applicable)	unsigned char	1	Numeric value (0 to 255)

#

In Simplified-Chinese Windows environment, database name of monitoring target SQL Server don't use out of range of GBK. If you use out of range of GBK in database name, PFM - Agent for SQL Server collect performance data fail. In this case, "KAVF21812-E" is output by agent log error file (detail information: rc=0x80040e37, msg include "?").

Field values

This section describes the values that are stored in the fields.

Data source

Each field contains a value obtained from a Performance Management product or program being monitored or the value derived there from by means of applying a formula. In the tables, the *Data source* column indicates the source of the value or the formula used to produce the value.

When a field's value is obtained by processing performance data acquired from Microsoft SQL Server, the character string in the Data source column in PFM - Agent for Microsoft SQL Server indicates the method used to obtain the value that is set in the field. In all other cases, the character string indicates the system table name of the Microsoft SQL Server or the Transact-SQL command batch to be used for acquiring data.

Note that if the character string in the *Data source* column consists of upper-case characters and begins with DBCC, the character string indicates a DBCC statement of Microsoft SQL Server. In other cases, the character string indicates the Manager name for the field in the record.

Delta

In contrast to the data collected as the cumulative value, the so-called delta is the data that indicates the changed amount. For example, if the performance data value obtained during the first collection is 3 and the performance data value obtained during the second collection is 4, then the cumulative value is 7 and the changed amount is 1. In the tables, the Delta column indicates whether or not each field's value is a delta value.

The following table explains the delta characteristics of performance data collected by PFM - Agent for Microsoft SQL Server:

Table 5–6: Performance data collected by PFM - Agent for Microsoft SQL Server

Record type	Delta	Data type	Indicate delta value#	Record value
PI record type	Yes	Real-time data	Selected	The displayed value is the changed amount.
			Not selected	The displayed value is the changed amount.
		- Historical data - Alarm monitoring data	N/A	The displayed value is the changed amount.
	No	Real-time data	Selected	The displayed value was the actual value at the time of data collection.
			Not selected	The displayed value was the actual value at the time of data collection.
		- Historical data - Alarm monitoring data	N/A	The displayed value was the actual value at the time of data collection.
PD record type	Yes	Real-time data	Selected	The displayed value is the change.
			Not selected	The displayed value is the cumulative value.

Record type	Delta	Data type	Indicate delta value [#]	Record value
PD record type	Yes	- Historical data - Alarm monitoring data	N/A	The displayed value is the cumulative value.
	No	Real-time data	Selected	The displayed value was the actual value at the time of data collection.
			Not selected	The displayed value was the actual value at the time of data collection.
	N/A	- Historical data - Alarm monitoring data	N/A	The displayed value was the actual value at the time of data collection.

Legend:

N/A: Not applicable

#

Indicates that the following check boxes are selected in the PFM - Web Console dialog box:

-**Indicate delta value** check box in the Report Wizard - Indication settings (Realtime) dialog box

-**Indicate delta value** check box in **Indication settings (Realtime)** on the **Properties** page of the Report window

The following points should be noted about collection of performance data:

- In the following cases, no value is displayed until the first data has been collected:
 - The **Indicate delta value** check box is selected in the settings for real-time reports based on PI records.
 - The **Indicate delta value** check box is selected in the settings for real-time reports based on PD records.
 However, in reports requiring previous data, the initial values are shown as zero. Starting with the second cycle, the changed amount is displayed.

Fields added only when data is stored in the Store database

The following table lists the fields that are added only when data is stored in the Store database:

Table 5–7: Fields added only when data is stored in the Store database

PFM - View name (PFM - Manager name)	Description	Format	Delta	Data source
Agent Host (DEVICEID)	Name of host where PFM - Agent for Microsoft SQL Server is running	string(256)	No	N/A
Agent Instance (PROD_INST)	Instance name of PFM - Agent for Microsoft SQL Server	string(256)	No	N/A
Agent Type (PRODID)	Product ID of PFM - Agent for Microsoft SQL Server (1-byte identifier)	char	No	N/A
Date (DATE)	Record creation date in (GMT) ^{#1, #2}	char(3)	No	N/A
Date and Time (DATETIME)	Combination of the Date (DATE) and Time (TIME) fields ^{#2}	char(6)	No	N/A
Drawer Type (DRAWER_TYPE)	For a PI record, the data summarization type.	char	No	N/A
GMT Offset (GMT_ADJUST)	Difference (in seconds) between Greenwich Mean Time and local time	long	No	N/A
Time (TIME)	Record creation time (GMT) ^{#1, #2}	char(3)	No	N/A

Legend:

N/A: The field value is specified without processing the performance data acquired from Microsoft SQL Server.

#1

A basic value is set because records of the PI record type are summarized. The following table shows the setting values for each record type.

Table 5–8: Setting value for each record type

Type	Setting value for each record type
Minute	0 second of the time when the record was created.
Hour	0 minute and 0 second of the time when the record was created.
Day	0:00 and 0 second of the day when the record was created.
Week	0:00 and 0 second on Monday of the week when the record was created.
Month	0:00 and 0 second on the 1st day of the month when the record was created.
Year	0:00 and 0 second on January 1st of the year when the record was created.

#2

When data is displayed in reports, the Date field is displayed in the format *YYYYMMDD*, the Date and Time field is displayed in the format *YYYYMMDD hh:mm:ss*, and the Time field is displayed in the format *hh:mm:ss*.

Fields output when data stored in the Store database is exported

When data stored in the Store database is exported by using the `jpctool db dump` command, the fields listed below are output. These fields are also added when data is stored in the Store database, but since they are used internally by PFM - Agent, they are not used as fields displayed in reports, and should not be used during operation.

- *Record ID_DATE_F*
- *Record ID_DEVICEID_F*
- *Record ID_DRAWER_TYPE_F*
- *Record ID_DRAWER_COUNT*
- *Record ID_DRAWER_COUNT_F*
- *Record ID_INST_SEQ*
- *Record ID_PRODID_F*
- *Record ID_PROD_INST_F*
- *Record ID_RECORD_TYPE*
- *Record ID_RECORD_TYPE_F*
- *Record ID_SEVERITY*
- *Record ID_SEVERITY_F*
- *Record ID_TIME_F*
- *Record ID_UOWID*
- *Record ID_UOWID_F*
- *Record ID_UOW_INST*
- *Record ID_UOW_INST_F*
- *Record ID_PFM - Manager name_COUNT*
- *Record ID_PFM - Manager name_SEC*
- *Record ID_PFM - Manager name_MSEC*
- *Record ID_PFM - Manager name_OV*

Notes on records

Note the following when collecting records.

Results of record generation when no data can be acquired

The following explains the results of record generation when no data can be acquired.

- No records are generated

In the following cases, no records are generated:

- PFM - Agent for Microsoft SQL Server cannot collect the performance data to be stored in a field that is defined as an ODBC key field.
- PFM - Agent for Microsoft SQL Server cannot collect the performance data to be stored in a field that shows Microsoft SQL Server performance.
- Mirror databases exist on the monitoring-target Microsoft SQL Server host (because PFM - Agent for Microsoft SQL Server cannot collect performance data from mirror databases).

- Records with empty fields are generated

In the following cases, records with empty fields are generated:

- PFM - Agent for Microsoft SQL Server cannot collect data of the character type.
- PFM - Agent for Microsoft SQL Server collects empty data of the character type.

- Records with a field value of -1 are generated

When PFM - Agent for Microsoft SQL Server cannot collect configuration data of the numeric type, records with a field value of -1 are generated.

- Records with a field value of Unknown are generated

In the following cases, records with a field value of Unknown are generated:

- PFM - Agent for Microsoft SQL Server collects data for a field that is defined in the data model, but whose data is not defined.
- PFM - Agent for Microsoft SQL Server cannot collect data for a field defined in the data model.

Record collection fails when the monitoring database is online

If the version of the monitoring-target Microsoft SQL Server is 2005 without SP1 or later, the following record collection from all the databases on the Microsoft SQL Server fails when any one of the databases which consist of the Microsoft SQL Server is turned offline. To collect the records listed below, turn online the databases you turned offline. #

- PD_DD record
- PD_DS record
- PD_RD record
- PD_RS record
- PD_SS record
- PI_DI record
- PI_RPDB record
- PI_SI record

#

If the version of the monitoring-target Microsoft SQL Server is 2005 with SP1 or later, PFM - Agent for Microsoft SQL Server can collect performance data from all the databases except offline databases.

Results of record collection when the session to the monitoring-target Microsoft SQL Server is disconnected

If the session to the monitoring-target Microsoft SQL Server is disconnected, the record collection may fail. In this case, when PFM - Agent for Microsoft SQL server collects the records next time, PFM - Agent for Microsoft SQL Server reestablish the connection to the Microsoft SQL Server and then start collecting the records.

List of records for PFM - Agent for Microsoft SQL Server

This section lists the records that can be collected by PFM - Agent for Microsoft SQL Server.

Table 5-10 lists the records that can be collected by PFM - Agent for Microsoft SQL Server and the information that is stored in each record. The records in the following table are listed in order of record name, respectively.

Table 5–9: List of records for PFM - Agent for Microsoft SQL Server

Record name	Record ID	Information stored in record
Config Detail	PD_CD	Information related to Microsoft SQL Server environment setting option
Database Detail	PD_DD	Database information (snapshot), such as the numbers of locks and processes related to a particular database
Database Interval	PI_DI	Interval information, such as the status related to a particular database
Database Replication Detail	PD_RD	Replication information of a particular database
Database Space Detail	PD_DS	Information related to the size of the disk space used by a particular database
Errorlog Error Detail	PD_EE	Detailed information related to the errors that occurred in Microsoft SQL Server This record is supported in Japanese, English and Chinese Windows environments only.
Errorlog Summary Detail	PD_ES	Summary of the errors that occurred in Microsoft SQL Server This record is supported in Japanese, English and Chinese Windows environments only.
Global Server Summary	PI	Information related to Microsoft SQL Server I/O, network, and so on
Global Server Summary 2	PI_PI2	Information related to Microsoft SQL Server I/O, network, and so on
Instance Availability	PD_IA	Information on the availability of the Microsoft SQL Server instance
Job History Detail	PD_JH	Job history information incorporated into the Microsoft SQL Server schedule
Licensing Detail	PD_LIC	Licensing information, such as the maximum number of Microsoft SQL Server connections allowed
Lock Detail	PD_LD	Detailed information related to database locks
Procedure Cache Detail	PD_PCAC	Information related to the procedure cache
Process Detail	PD_PDET	Detailed information on a particular database process, such as locks and I/O
Replication Published Database Overview	PI_RPDB	Replication information related to database distribution transactions and so on
Replication Summary Detail	PD_RS	Summary of database replication generated by Microsoft SQL Server
Server Detail	PD	Detailed information on Microsoft SQL Server, such as locks and I/O
Server Locks Detail	PD_LOCK	Information related to Microsoft SQL Server locks
Server Overview	PI_SERV	Overall information related to Microsoft SQL Server, such as the rate of cache hits and I/O
Server Overview 2	PI_SRV2	Overall information related to Microsoft SQL Server, such as the rate of cache hits and I/O
Server Space Detail	PD_SS	Information related to the size of the disk space used by Microsoft SQL Server

Record name	Record ID	Information stored in record
Server Space Interval	PI_SI	Interval information related to the size of the disk space used by Microsoft SQL Server
SQL Text	PD_SQL	This record displays the execution information on the last query issued by the process
Transaction Log Overview	PI_TLOG	Information related to transaction log space
User-Defined Counter Overview	PI_UCTR	Information related to each user-defined counter
User Process Detail	PD_USER	Information related to each logged-on user
Errorlog Summary Interval	PI_ESI	This record is reserved and cannot be used.
Generic Data Detail	PD_GEND	
Generic Data Interval	PI_GENI	
Restore History Detail	PD_RH	
SQL Text - Performance-Based	PD_PDES	

Config Detail (PD_CD)

Function

The Config Detail (PD_CD) record indicates information related to Microsoft SQL Server environment setting options. One record is created for each environment setting option.

This is a multi-instance record.

Default and changeable values

Item	Default value	Changeable
Collection Interval	60	Y
Collection Offset	0	Y
Log	No	Y
LOGIF	(Blank)	Y
Over 10 Sec Collection Time	No	N

ODBC key field

PD_CD_NAME

Lifetime

From creation to deletion of a Microsoft SQL Server instance

Record size

- Fixed part: 681 bytes
- Variable part: 157 bytes

Fields

View name (Manager name)	Description	Summary	Format	Delta	Data source
Config Value (CONFIG_VALUE)	Environment setting option value	--	long	No	sp_configure.config_value
Current Run Value (RUN_VALUE)	Environment setting option value (execution value at data collection)	--	long	No	sp_configure.run_value
Max Value (MAXIMUM)	Maximum value of environment setting option	--	long	No	sp_configure.maximum
Min Value (MINIMUM)	Minimum value of environment setting option	--	long	No	sp_configure.minimum
Name (NAME)	Name of environment setting option	--	string(141)	No	sp_configure.name
Record Time (RECORD_TIME)	Interval end time (GMT format)	--	time_t	No	Agent Collector
Record Type	Record type (always CD)	--	char(8)	No	Agent Collector

View name (Manager name)	Description	Summary	Format	Delta	Data source
(INPUT_RECORD_TYPE)	Record type (always CD)	--	char(8)	No	Agent Collector
Start Time (START_TIME)	Interval start time (GMT format)	--	time_t	No	Agent Collector

Database Detail (PD_DD)

Function

The Database Detail (PD_DD) record indicates database information (snapshot), such as the numbers of locks and processes, related to a particular database. One record is created for each database. This is a multi-instance record.

Default and changeable values

Item	Default value	Changeable
Collection Interval	60	Y
Collection Offset	0	Y
Log	No	Y
LOGIF	(Blank)	Y
Over 10 Sec Collection Time	No	N

ODBC key field

- PD_DD_DB_NAME
- PD_DD_DBID

Lifetime

From creation to deletion of a database

Record size

- Fixed part: 681 bytes
- Variable part: 1,372 bytes

Fields

View name (Manager name)	Description	Summary	Format	Delta	Data source	
					SQL Server version 2014 or earlier	SQL Server version 2016 or later
Availability (AVAILABILITY)	Database status. The following values are valid: Active Enabled. Process is running. Available Enabled. No process is running. NOT Available A crash or problem may have occurred during loading, and as a result the database cannot be opened or used in its current state.	--	string(16)	No	master..sysdatabases .status	sys.databases.state

View name (Manager name)	Description	Summary	Format	Delta	Data source	
					SQL Server version 2014 or earlier	SQL Server version 2016 or later
Availability (AVAILABILITY)	Restricted Database can be used only by its owner or a single user.	--	string(16)	No	master.sysdatabases .status	sys.databases.state
Blocked Processes (BLOCKED)	Number of blocked processes	--	word	No	Total number of processes for which the master..syspr ocesses.block ed value is not 0	Total number of processes for which the sys.dm_exec_reques ts.blocking_session _id value is not 0
Blocking Locks (BLOCKING)	Number of blocking locks	--	ulong	No	Number of locks for which the master..syslo ckinfo.req_st atus value is 3 (standby)	Number of locks for which the sys.dm_tran_locks.r equest_status value is WAIT, LOW_PRIORITY_ WAIT, or ABORT_BLOCKE RS
Create Date (CREATE_DATE)	Database creation date	--	time_t	No	master.sysdatabases .crdate	sys.databases.create _date
DB Name (DB_NAME)	Database name	--	string(257)	No	master.sysdatabases .name	sys.databases.name
DB Owner (DBO)	Database owner	--	string(513)	No	Name of the user for which master..sysda tabases.sid is equal to master..syslo gins.sid	Name of the user for which sys.databases.owner _sid is equal to sys.server_principal s.sid
DBID (DBID)	Database ID	--	ulong	No	master.sysdatabases .dbid	sys.databases.databa se_id
Demand Locks (DEMAND)	Number of request locks	--	ulong	No	master.syslockinfo	sys.dm_tran_locks
Exclusive Intent Locks (EXCLUSIVE_IN TENT)	Number of exclusive intent locks	--	ulong	No	master.syslockinfo	sys.dm_tran_locks
Exclusive Page Locks (EXCLUSIVE_PA GE)	Number of exclusive page locks	--	ulong	No	master.syslockinfo	sys.dm_tran_locks
Exclusive Table Locks (EXCLUSIVE_TA BLE)	Number of exclusive table locks	--	ulong	No	master.syslockinfo	sys.dm_tran_locks
Last Dump Date (LAST_DUMP)	Last dump date for the transaction log	--	time_t	No	msdb.dbo.backupset	

View name (Manager name)	Description	Summary	Format	Delta	Data source	
					SQL Server version 2014 or earlier	SQL Server version 2016 or later
Locks (LOCKS)	Total number of locks	--	ulong	No	master..syslockinfo	sys.dm_tran_locks
Options (OPTIONS)	Database options currently specified. Delimited by commas.	--	string(512)	No	master..sysdatabases. .status, master..sysdatabases. .status2	sys.databases
Other Processes (OTHER)	Number of other types of processes	--	word	No	master..sysprocesses. .status	sys.dm_exec_sessions. status
Process Count (PROCESSES)	Total number of processes	--	word	No	master..sysprocesses	sys.dm_exec_sessions
Record Time (RECORD_TIME)	Interval end time (GMT format)	--	time_t	No	Agent Collector	
Record Type (INPUT_RECORD_TYPE)	Record type (always DD)	--	char(8)	No	Agent Collector	
Runnable Processes (RUNNABLE)	Number of executable processes	--	word	No	master..sysprocesses. .status	sys.dm_exec_sessions. status
Running Processes (RUNNING)	Number of processes being executed	--	word	No	master..sysprocesses. .status	sys.dm_exec_sessions. status
Shared Intent Locks (SHARED_INTENT)	Number of shared intent locks	--	ulong	No	master..syslockinfo. rsc_type, master..syslockinfo. req_mode	sys.dm_tran_locks.r esource_type, sys.dm_tran_locks.r equest_mode
Shared Page Locks (SHARED_PAGE)	Number of shared page locks	--	ulong	No	master..syslockinfo. rsc_type, master..syslockinfo. req_mode	sys.dm_tran_locks.r esource_type, sys.dm_tran_locks.r equest_mode
Shared Table Locks (SHARED_TABLE)	Number of shared table locks	--	ulong	No	master..syslockinfo. rsc_type, master..syslockinfo. req_mode	sys.dm_tran_locks.r esource_type, sys.dm_tran_locks.r equest_mode
Sleeping Processes (SLEEPING)	Number of sleeping processes	--	word	No	master..sysprocesses. .status	sys.dm_exec_sessions. status
Start Time (START_TIME)	Interval start time (GMT format)	--	time_t	No	Agent Collector	
Trans (TRANS)	Total number of transactions	--	double	No	master..sysperfinfo.t ransactions/sec	sys.dm_os_perform ance_counters.trans actions/sec
Update Page Locks (UPDATE_PAGE)	Number of update page locks	--	ulong	No	master..syslockinfo. rsc_type, master..syslockinfo. req_mode	sys.dm_tran_locks.r esource_type, sys.dm_tran_locks.r equest_mode

View name (Manager name)	Description	Summary	Format	Delta	Data source	
					SQL Server version 2014 or earlier	SQL Server version 2016 or later
Version (VERSION)	<p>SQL Server version 2016 or earlier: Microsoft SQL Server version used for database creation</p> <p>SQL Server version 2016 or later: Value indicating the version of Microsoft SQL Server with operational compatibility</p>	--	word	No	master..sysdatabases. .version	sys.databases.comp atibility_level

Database Interval (PI_DI)

Function

The Database Interval (PI_DI) record indicates interval information, such as the status related to a particular database. One record is created for each database.

This is a multi-instance record.

Default and changeable values

Item	Default value	Changeable
Collection Interval	60	Y
Collection Offset	0	Y
Log	No	Y
LOGIF	(Blank)	Y
Over 10 Sec Collection Time	No	N

ODBC key fields

- PI_DI_DB_NAME
- PI_DI_DBID

Lifetime

From the creation until deletion of a database

Record size

- Fixed part: 681 bytes
- Variable part: 1,398 bytes

Fields

View name (Manager name)	Description	Summary	Format	Delta	Data source	
					SQL Server version 2014 or earlier	SQL Server version 2016 or later
Availability (AVAILABILITY)	Database status. The following values are valid: ^{#1} Active Enabled. A process is running. Available Enabled. No process is running. NOT Available A crash or problem might have occurred during loading, and, as a result, the database cannot be opened or used in its current state. Restricted	COPY	string(16)	No	master..sysdatabases.status	sys.databases.state

View name (Manager name)	Description	Summary	Format	Delta	Data source	
					SQL Server version 2014 or earlier	SQL Server version 2016 or later
Availability (AVAILABILITY)	The database can be used only by its owner or a single user.	COPY	string(16)	No	master..sysdatabases.status	sys.databases.state
DB Name (DB_NAME)	Database name ^{#1}	COPY	string(257)	No	master..sysdatabases.name	sys.databases.name
DB Owner (DBO)	Database owner ^{#1}	COPY	string(513)	No	User's logon ID for which master..sysdatabases.sid = master..syslogins.sid	User's logon name for which sys.databases.owner_sid = sys.server_principals.sid
DBID (DBID)	Database ID ^{#1}	COPY	ulong	No	master..sysdatabases.dbid	sys.databases.database_id
Data Growth % (DATA_GROWTH)	Rate of increase of data space during the interval ^{#2}	AVG	double	No	sys.partitions, sys.allocation_units, sys.internal_tables	
Index Growth % (IDX_GROWTH)	Rate of increase of index space during the interval ^{#2}	AVG	double	No	sys.partitions, sys.allocation_units, sys.internal_tables	
Log Growth % (LOG_GROWTH)	Rate of increase of log space during the interval ^{#2}	AVG	double	No	DBCC SQLPERF(LOGSPACE)	
Options (OPTIONS)	Database options currently specified. Options are delimited by commas. ^{#1}	COPY	string(512)	No	master..sysdatabases.status, master..sysdatabases.status2	sys.databases
Record Time (RECORD_TIME)	Interval end time (GMT format) ^{#1}	COPY	time_t	No	Agent Collector	
Record Type (INPUT_RECORD_TYPE)	Record type (always DI) ^{#1}	COPY	char(8)	No	Agent Collector	
Start Time (START_TIME)	Interval start time (GMT format) ^{#1}	COPY	time_t	No	Agent Collector	
Tran Log Dumps (DUMPED_TRAN)	Number of transaction log dumps collected during the relevant interval ^{#2}	AVG	long	Yes	msdb.dbo.backupset	
Trans/sec (TRAN_SEC)	Number of transactions per second ^{#2}	AVG	double	Yes	master..sysperfnfo.transactions/sec	sys.dm_os_performance_counters.transactions/sec

Database Replication Detail (PD_RD)

Function

The Database Replication Detail (PD_RD) record indicates the replication information of a particular database. One record is created for each replication of the database.

This is a multi-instance record.

As indicated in the following table, the fields that can be acquired for this record differ depending on the database type.

Field	Database type		
	Publisher	Distributor	Subscriber and others
Articles	Yes	No	No
Publications	Yes	No	No
Subscriptions	Yes	No	No
None of the above	Yes	Yes	Yes

When a field cannot be acquired, the value is 0.

Default and changeable values

Item	Default value	Changeable
Collection Interval	60	Y
Collection Offset	0	Y
Log	No	Y
LOGIF	(Blank)	Y
Over 10 Sec Collection Time	No	N

ODBC key fields

PD_RD_DBID

Lifetime

From the creation until deletion of a database

Record size

- Fixed part: 681 bytes
- Variable part: 273 bytes

Fields

View name (Manager name)	Description	Summary	Format	Delta	Data source	
					SQL Server version 2014 or earlier	SQL Server version 2016 or later
Articles (ARTICLES)	Number of articles published by the database	--	ulong	No	Each publication database's sysarticles table	
DB Name (DB_NAME)	Database name	--	string(257)	No	master..sysdatabases.name	sys.databases.name
DBID (DBID)	Database ID	--	ulong	No	master..sysdatabases.dbid	sys.databases.database_id
Publications (PUBLICATIONS)	Number of publications posted by the publishing server	--	ulong	No	Each publication database's syspublications table	
Record Time (RECORD_TIME)	Interval end time (GMT format)	--	time_t	No	Agent Collector	
Record Type (INPUT_RECORD_TYPE)	Record type (always RD)	--	char(8)	No	Agent Collector	
Start Time (START_TIME)	Interval start time (GMT format)	--	time_t	No	Agent Collector	
Subscriptions (SUBSCRIPTIONS)	Number of database subscriptions	--	ulong	No	Each publication database's syssubscriptions table	

Database Space Detail (PD_DS)

Function

The Database Space Detail (PD_DS) record indicates information related to the size of the disk space used by a particular database. One record is created for each database. This is a multi-instance record.

The free space in the database (data space and log space) can be monitored using the Free Mbytes and Free % views.

The free space in the data space can be monitored using Data Unallocate Mbytes and Data Unallocate % views.

The following figure shows the relationship between fields that collect space data that the database has.

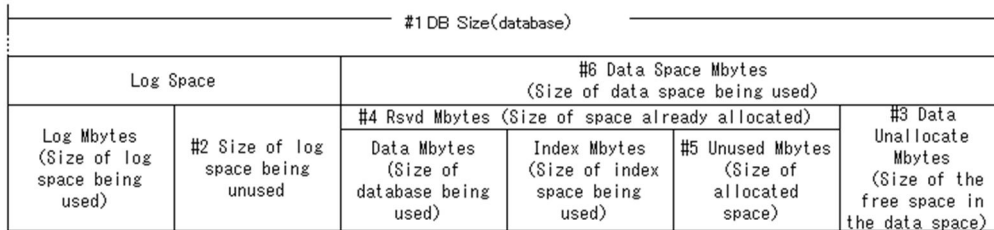

Formula for the fields related to the percentage of space and space

- Free Mbytes (Size of the free space)

$$[\#2 \text{ Size of log space being unused}] + [\#3 \text{ Data Unallocate Mbytes}]$$
- Free % (Free space as a percentage of the size)

$$([\#2 \text{ Size of log space being unused}] + [\#3 \text{ Data Unallocate Mbytes}]) / [\#1 \text{ DB Size}] * 100$$
- Unused % (Unused space as a percentage of total allocated space)

$$[\#5 \text{ Unused Mbytes}] / [\#4 \text{ Rsvd Mbytes}] * 100$$
- Data Unallocate % (Free space as a percentage of the data space)

$$[\#3 \text{ Data Unallocate Mbytes}] / [\#6 \text{ Data Space Mbytes}] * 100$$

Default and changeable values

Item	Default value	Changeable
Collection Interval	60	Y
Collection Offset	0	Y
Log	No	Y
LOGIF	(Blank)	Y
Over 10 Sec Collection Time	No	N

ODBC key fields

- PD_DS_DB_NAME
- PD_DS_DBID

Lifetime

From the creation until deletion of a database

Record size

- Fixed part: 681 bytes
- Variable part: 357 bytes

Fields

View name (Manager name)	Description	Summary	Format	Delta	Data source	
					SQL Server version 2014 or earlier	SQL Server version 2016 or later
DB Name (DB_NAME)	Database name	--	string(257)	No	master..sysdatabases .name	sys.databases.name
DB Size (SIZE)	Database size (in megabytes)	--	double	No	dbo.sysfiles	sys.database_files
DBID (DBID)	Database ID	--	ulong	No	master..sysdatabases .dbid	sys.databases.databa se_id
Data Mbytes (DATA)	Size of data space being used (in megabytes)	--	double	No	sys.partitions, sys.allocation_units, sys.internal_tables	
Data Space Mbytes (DATA_SPACE_ MB)	Size of the data space (in megabytes)	--	double	No	sys.partitions, sys.allocation_units, sys.internal_tables	
Data Unallocate Mbytes (DATA_UNALLO CATE_MB)	Size of the free space in the data space (in megabytes)	--	double	No	sys.partitions, sys.allocation_units, sys.internal_tables	
Data Unallocate % (DATA_UNALLO CATE_RATIO)	Free space as a percentage of the data space	--	double	No	sys.partitions, sys.allocation_units, sys.internal_tables	
Free % (PERC_FREE)	Free space as a percentage of the size of the entire database, including data files and transaction log files	--	double	No	dbo.sysfiles, sys.partitions, sys.allocation_units, sys.internal_tables	sys.database_files, sys.partitions, sys.allocation_units, sys.internal_tables
Free Mbytes (FREE_SPACE)	Size of the free space in the area allocated to the entire database, including data files and transaction log files (in megabytes)	--	double	No	dbo.sysfiles, sys.partitions, sys.allocation_units, sys.internal_tables	sys.database_files, sys.partitions, sys.allocation_units, sys.internal_tables
Index Mbytes (IDX)	Size of index space being used (in megabytes)	--	double	No	sys.partitions, sys.allocation_units, sys.internal_tables	
Log Mbytes (LOG)	Size of log space being used (in megabytes)	--	double	No	DBCC SQLPERF(LOGSPACE)	
Record Time (RECORD_TIME)	Interval end time (GMT format)	--	time_t	No	Agent Collector	
Record Type (INPUT_RECOR D_TYPE)	Record type (always DS)	--	char(8)	No	Agent Collector	
Rsvd Mbytes (RESERVED)	Size of space already allocated (in megabytes)	--	double	No	sys.partitions, sys.allocation_units, sys.internal_tables	
Start Time (START_TIME)	Interval start time (GMT format)	--	time_t	No	Agent Collector	
Unused % (PERC_USED)	Unused space as a percentage of total allocated space	--	double	No	sys.partitions, sys.allocation_units, sys.internal_tables	

View name (Manager name)	Description	Summary	Format	Delta	Data source	
					SQL Server version 2014 or earlier	SQL Server version 2016 or later
Unused Mbytes (UNUSED)	Size of allocated but unused space (in megabytes)	--	double	No	sys.partitions, sys.allocation_units, sys.internal_tables	

Errorlog Error Detail (PD_EE)

Function

The Errorlog Error Detail (PD_EE) record contains detailed information related to the errors that occurred in Microsoft SQL Server. One record is created for each error recorded in the error log.

This is a multi-instance record.

If the OS is Windows in Japanese, English or Chinese environment, strings whose meaning correspond to Error in each language are collected. This record is not supported by Windows in other language environments.

When the real-time report is displayed, this record displays all errors recorded in the Microsoft SQL Server error log. If you are monitoring operations by collecting history or using alarms, errors that have occurred since the previous collection will be collected.

If a failure occurs in Microsoft SQL Server, the same error might continue to be output to the Microsoft SQL Server error log many times. In such cases, if you collect the Errorlog Error Detail (PD_EE) record, the following events might occur:

- The capacity of the Store database increases.
- Collecting the record takes a long time, and the collection of other records will be skipped until the collection of the Lock Detail record finishes.
- A lot of memory is consumed.

If you collect histories or monitor operations by using alarms, you can use the instance information item `LIMIT_PD_EE_NUMBER` to set the maximum number of errors to be collected from the errors that occurred during the collection interval.

For details about the `LIMIT_PD_EE_NUMBER` item, see [2.1.4\(2\)\(a\) Set up instance information](#).

Default and changeable values

Item	Default value	Changeable
Collection Interval	300	Y
Collection Offset	0	Y
Log	No	Y
LOGIF	(Blank)	Y
Over 10 Sec Collection Time	No	N

ODBC key field

- PD_EE_COUNT
- PD_EE_ERROR
- PD_EE_ERROR_TIME
- PD_EE_ERROR_TIME_MSEC
- PD_EE_ERROR_SEVERITY

Lifetime

From the time the error log file is created until the time it is deleted

Record size

- Fixed part: 681 bytes
- Variable part: 348 bytes

Fields

View name (Manager name)	Description	Summary	Format	Delta	Data source
Count (COUNT)	Serial numbers assigned by PFM - Agent for Microsoft SQL Server to errors that occur at the same time	--	word	No	Microsoft SQL Server error log
Error # (ERROR)	Error number	--	long	No	Microsoft SQL Server error log
Error Time (ERROR_TIME)	Error occurrence time	--	time_t	No	Microsoft SQL Server error log
Error Time Msec (ERROR_TIME_MSEC)	Millisecond portion of the error occurrence time	--	word	No	Microsoft SQL Server error log
Message (MESSAGE)	Error message character string. Characters beyond the 300-byte length are discarded.	--	string(300)	No	Microsoft SQL Server error log
Process (PROCESS)	Error location (process name)	--	string(32)	No	Microsoft SQL Server error log
Record Time (RECORD_TIME)	Interval end time (GMT format)	--	time_t	No	Agent Collector
Record Type (INPUT_RECORD_TYPE)	Record type (always EE)	--	char(8)	No	Agent Collector
Severity (ERROR_SEVERITY)	Error message severity level	--	word	No	Microsoft SQL Server error log
Start Time (START_TIME)	Interval start time (GMT format)	--	time_t	No	Agent Collector
State (STATE)	Error message state code	--	word	No	Microsoft SQL Server error log

Errorlog Summary Detail (PD_ES)

Function

The Errorlog Summary Detail (PD_ES) record indicates a summary of the errors that occurred in Microsoft SQL Server. Only one record is created.

If the OS is Windows in Japanese, English or Chinese environment, strings whose meaning correspond to Error in each language are collected. This record is not supported by Windows in other language environments.

This record collects the total number of errors that were output to the Microsoft SQL Server error log. Note that this record counts all errors, even if the number of Microsoft SQL Server errors output exceeds the value set for the instance information item LIMIT_PD_EE_NUMBER.

Default and changeable values

Item	Default value	Changeable
Collection Interval	300	Y
Collection Offset	0	Y
Log	No	Y
LOGIF	(Blank)	Y
Over 10 Sec Collection Time	No	N

ODBC key field

None

Lifetime

From the time the error log file is created until the time it is deleted

Record size

- Fixed part: 701 bytes
- Variable part: 0 bytes

Fields

View name (Manager name)	Description	Summary	Format	Delta	Data source
Errorlog Errors (ERRORLOG_ERRORS)	Total number of errors recorded in the error log	--	ulong	No	Microsoft SQL Server error log
Fatal Errors (FATAL_ERRORS)	Total number of fatal errors recorded in the error log	--	ulong	No	Microsoft SQL Server error log
Internal Errors (INTERNAL_ERRORS)	Total number of internal errors recorded in the error log	--	ulong	No	Microsoft SQL Server error log
Last Error Time (LAST_ERROR)	Time at which the last error occurred	--	time_t	No	Microsoft SQL Server error log

View name (Manager name)	Description	Summary	Format	Delta	Data source
Record Time (RECORD_TIME)	Interval end time (GMT format)	--	time_t	No	Agent Collector
Record Type (INPUT_RECORD_TYPE)	Record type (always ES)	--	char(8)	No	Agent Collector
Resource Errors (RESOURCE_ERRORS)	Total number of resource errors recorded in the error log	--	ulong	No	Microsoft SQL Server error log
Start Time (START_TIME)	Interval start time (GMT format)	--	time_t	No	Agent Collector

Global Server Summary (PI)

Function

The Global Server Summary (PI) record indicates information related to the Microsoft SQL Server I/O and network. One record is created for each interval.

Default and changeable values

Item	Default value	Changeable
Collection Interval	60	Y
Collection Offset	0	Y
Log	Yes	Y
LOGIF	(Blank)	Y
Over 10 Sec Collection Time	No	N

ODBC key field

None

Lifetime

From the start until stop of a Microsoft SQL Server instance

Record size

- Fixed part: 1,100 bytes
- Variable part: 0 bytes

Fields

View name (Manager name)	Description	Summary	Format	Delta	Data source	
					SQL Server version 2014 or earlier	SQL Server version 2016 or later
CPU % (PERC_BUSY)	Percentage of time CPU is busy#2 This field cannot display correct value.	AVG	double	No	CPU_BUSY / (CPU_BUSY + IDLE + IO_BUSY) * 100	
CPU Time (CPU_TIME)	CPU busy time (in seconds and milliseconds) #2 This field cannot display correct value.	AVG	utime	Yes	@@cpu_busy / 1000	
CPU Timeticks (CPU_BUSY)	CPU usage time (in ticks) This field cannot display correct value.	ADD BI	ulong	Yes	@@cpu_busy * 1000 / @@timeticks	
Cache Avg Scan (CACHE_AVG_SCAN)	This field is reserved and cannot be used.	AVG	--	--	--	
Conns	Number of client connections#2	AVG	ulong	No	@@connections	

View name (Manager name)	Description	Summary	Format	Delta	Data source	
					SQL Server version 2014 or earlier	SQL Server version 2016 or later
(CONNECTIONS)	Number of client connections ^{#2}	AVG	ulong	No	@@connections	
I/O %(PERC_IO)	Percentage of CPU time spent for I/O ^{#2} This field cannot display correct value.	AVG	double	No	IO_BUSY / (CPU_BUSY + IDLE + IO_BUSY) * 100	
I/O Time(IO_TIME)	CPU time spent for I/O (in seconds and milliseconds) ^{#2} This field cannot display correct value.	AVG	utime	Yes	@@io_busy / 1000	
I/O Timeticks (IO_BUSY)	CPU I/O time (in ticks) This field cannot display correct value.	ADD BI	ulong	Yes	@@io_busy * 1000 / @@timeticks	
Idle % (PERC_IDLE)	Percentage of time CPU is idle ^{#2} This field cannot display correct value.	AVG	double	No	IDLE / (CPU_BUSY + IDLE + IO_BUSY) * 100	
Idle Time (IDLE_TIME)	CPU idle time (in seconds and milliseconds) ^{#2} This field cannot display correct value.	AVG	utime	Yes	@@idle / 1000	
Idle Timeticks (IDLE)	CPU idle time (in ticks) This field cannot display correct value.	ADD BI	ulong	Yes	@@idle * 1000 / @@timeticks	
Lazy Writes/sec (LAZY_WRITES_SEC)	Total number of pages flushed by Lazy Writer to a disk (1 page equals 8 kilobytes) ^{#2}	AVG	double	No	master..sysperfinfo	Lazy Writes/sec (LAZY_WRITES_SEC)
Log Writes/sec (LOG_WRITES_SEC)	Total number of log pages written onto a disk ^{#2}	AVG	double	No	master..sysperfinfo	Log Writes/sec (LOG_WRITES_SEC)
Net Queue (NET_QUEUE)	This field is reserved and cannot be used.	AVG	--	--	--	
Net Reads/sec (NET_READS_SEC)	This field is reserved and cannot be used.	AVG	--	--	--	
Net Writes/sec (NET_WRITES_SEC)	This field is reserved and cannot be used.	AVG	--	--	--	
Pkt Errors (PACKET_ERRORS)	Number of packet errors ^{#2}	AVG	ulong	Yes	@@packet_errors	
Pkts Rcvd (PACK_RECEIVED)	Number of packets received ^{#2}	AVG	ulong	Yes	@@pack_received	
Pkts Sent (PACK_SENT)	Number of packets sent ^{#2}	AVG	ulong	Yes	@@pack_sent	

View name (Manager name)	Description	Summary	Format	Delta	Data source	
					SQL Server version 2014 or earlier	SQL Server version 2016 or later
Reads Pending (READS_PENDING)	This field is reserved and cannot be used.	AVG	--	--	--	
Record Time (RECORD_TIME)	Interval end time (GMT format) #1	COPY	time_t	No	Agent Collector	
Record Type (INPUT_RECORD_TYPE)	Record type (always PI) #1	COPY	char(8)	No	Agent Collector	
Start Time (START_TIME)	Interval start time (GMT format) #1	COPY	time_t	No	Agent Collector	
Timeticks (TIMETICKS)	Microseconds per tick#1	COPY	ulong	No	@@timeticks	
Total Errors (TOTAL_ERRORS)	Number of disk errors#2	AVG	ulong	Yes	@@total_errors	
Total Reads (TOTAL_READ)	Number of disk read operations#2	AVG	ulong	Yes	@@total_read	
Total Writes (TOTAL_WRITE)	Number of disk write operations Number of disk write operations#2	AVG	ulong	Yes	@@total_write	
Trans/sec (TRANS_SEC)	Total number of Transact-SQL command batches executed #2	AVG	double	No	master..sysperfmio	sys.dm_os_performance_counters
Writes Pending (WRITES_PENDING)	This field is reserved and cannot be used.	AVG	--	--	--	

Global Server Summary 2 (PI_PI2)

Function

The Global Server Summary 2(PI_PI2) record indicates information related to the Microsoft SQL Server I/O and network. The Global Server Summary 2(PI_PI2) record acquires from the Microsoft SQL Server the values of the fields which store the cumulative values for "/sec" counters and uses those values to calculate the per-sec value. One record is created for each interval.

Default and changeable values

Item	Default value	Changeable
Collection Interval	60	Y
Collection Offset	0	Y
Log	Yes	Y
LOGIF	(Blank)	Y
Over 10 Sec Collection Time	No	N

ODBC key field

None

Lifetime

From the start until stop of a Microsoft SQL Server instance

Record size

- Fixed part: 1,100 bytes
- Variable part: 0 bytes

Fields

View name (Manager name)	Description	Summary	Format	Delta	Data source	
					SQL Server version 2014 or earlier	SQL Server version 2016 or later
CPU % (PERC_BUSY)	Percentage of time CPU is busy ^{#2} This field cannot display correct value.	AVG	double	No	CPU_BUSY / (CPU_BUSY + IDLE + IO_BUSY) * 100	
CPU Time (CPU_TIME)	CPU busy time (in seconds and milliseconds) ^{#2} This field cannot display correct value.	AVG	utime	Yes	@@cpu_busy / 1000	
CPU Timeticks (CPU_BUSY)	CPU usage time (in ticks) This field cannot display correct value.	ADD BI	ulong	Yes	@@cpu_busy * 1000 / @@timeticks	
Cache Avg Scan (CACHE_AVG_SCAN)	This field is reserved and cannot be used.	AVG	--	--	--	

View name (Manager name)	Description	Summary	Format	Delta	Data source	
					SQL Server version 2014 or earlier	SQL Server version 2016 or later
Conns (CONNECTIONS)	Number of client connections ^{#2}	AVG	ulong	No	@@connections	
I/O %(PERC_IO)	Percentage of CPU time spent for I/O ^{#2} This field cannot display correct value.	AVG	double	No	IO_BUSY / (CPU_BUSY + IDLE + IO_BUSY) * 100	
I/O Time(IO_TIME)	CPU time spent for I/O (in seconds and milliseconds) ^{#2} This field cannot display correct value.	AVG	utime	Yes	@@io_busy / 1000	
I/O Timeticks (IO_BUSY)	CPU I/O time (in ticks) This field cannot display correct value.	ADD BI	ulong	Yes	@@io_busy * 1000 / @@timeticks	
Idle % (PERC_IDLE)	Percentage of time CPU is idle ^{#2} This field cannot display correct value.	AVG	double	No	IDLE / (CPU_BUSY + IDLE + IO_BUSY) * 100	
Idle Time (IDLE_TIME)	CPU idle time (in seconds and milliseconds) ^{#2} This field cannot display correct value.	AVG	utime	Yes	@@idle / 1000	
Idle Timeticks (IDLE)	CPU idle time (in ticks) This field cannot display correct value.	ADD BI	ulong	Yes	@@idle * 1000 / @@timeticks	
Lazy Writes/sec (LAZY_WRITES_SEC)	Number of pages per second flushed by Lazy Writer to a disk within an interval (1 page equals 8 kilobytes) ^{#2}	AVG	double	No	master..sysperfinfo	sys.dm_os_performance_counters
Log Writes/sec (LOG_WRITES_SEC)	Number of log pages per second written onto a disk within an interval ^{#2}	AVG	double	No	master..sysperfinfo	sys.dm_os_performance_counters
Net Queue (NET_QUEUE)	This field is reserved and cannot be used.	AVG	--	--	--	
Net Reads/sec (NET_READS_SEC)	This field is reserved and cannot be used.	AVG	--	--	--	
Net Writes/sec (NET_WRITES_SEC)	This field is reserved and cannot be used.	AVG	--	--	--	
Pkt Errors (PACKET_ERRORS)	Number of packet errors ^{#2}	AVG	ulong	Yes	@@packet_errors	
Pkts Rcvd (PACK_RECEIVED)	Number of packets received ^{#2}	AVG	ulong	Yes	@@pack_received	

View name (Manager name)	Description	Summary	Format	Delta	Data source	
					SQL Server version 2014 or earlier	SQL Server version 2016 or later
Pkts Sent (PACK_SENT)	Number of packets sent ^{#2}	AVG	ulong	Yes	@@pack_sent	
Reads Pending (READS_PENDING)	This field is reserved and cannot be used.	AVG	--	--	--	
Record Time (RECORD_TIME)	Interval end time (GMT format) #1	COPY	time_t	No	Agent Collector	
Record Type (INPUT_RECORD_TYPE)	Record type (always PI2) #1	COPY	char(8)	No	Agent Collector	
Start Time (START_TIME)	Interval start time (GMT format) #1	COPY	time_t	No	Agent Collector	
Timeticks (TIMETICKS)	Microseconds per tick ^{#1}	COPY	ulong	No	@@timeticks	
Total Errors (TOTAL_ERRORS)	Number of disk errors ^{#2}	AVG	ulong	Yes	@@total_errors	
Total Reads (TOTAL_READ)	Number of disk read operations ^{#2}	AVG	ulong	Yes	@@total_read	
Total Writes (TOTAL_WRITE)	Number of disk write operations Number of disk write operations ^{#2}	AVG	ulong	Yes	@@total_write	
Trans/sec (TRANS_SEC)	Number of Transact-SQL command batches per second executed within an interval #2	AVG	double	Yes ^{#3}	master.sysperfinfo	sys.dm_os_performance_counters
Writes Pending (WRITES_PENDING)	This field is reserved and cannot be used.	AVG	--	--	--	

#3

The delta is calculated based on the changed amount of data acquired from SQL Server data base.

Instance Availability (PD_IA)

Function

The Instance Availability (PD_IA) record provides information on the availability of the Microsoft SQL Server instance. Only one record is created. To create this record, RM for Microsoft SQL Server attempts to connect to Microsoft SQL Server and then, after a successful connection, immediately disconnects.

Notes:

- If, before the PD_IA record is collected, the maximum number of sessions that have been given permission to connect to the Microsoft SQL Server instance has been reached, the Availability field in the PD_IA record indicates 0 (inactive), but the other records might be obtained normally.
- If the Microsoft SQL Server instance stops operating during record collection, the Availability field in the PD_IA record indicates 0 (inactive), but the other records might be obtained normally.
- If the Microsoft SQL Server instance that was inactive during record collection starts operating, the Availability field in the PD_IA record indicates 1 (active), but the other records might not be obtained.
- If an Instance Availability (PD_IA) record is created while Microsoft SQL Server is inactive, the next creation of an Instance Availability (PD_IA) record will be skipped when the following condition is satisfied:

Condition:

`-LOGIN_TIMEOUT >= collection-interval-of-the-Instance-Availability(PD_IA)-record`

Default and changeable values

Item	Default value	Changeable
Collection Interval	60	Y
Collection Offset	0	Y
Log	No	Y
LOGIF	(Blank)	Y
Over 10 Sec Collection Time	No	N

ODBC key field

None

Lifetime

None

Record size

- Fixed part: 987 bytes
- Variable part: 0 bytes

Fields

View name (Manager name)	Description	Summary	Format	Delta	Data source
Availability	Availability status; valid value is 0 (inactive) or 1 (active)	--	word	No	Agent Collector

View name (Manager name)	Description	Summary	Format	Delta	Data source
(AVAILABILITY)	Availability status; valid value is 0 (inactive) or 1 (active)	--	word	No	Agent Collector
Collect Time (COLLECT_TIME)	Time spent connecting to and disconnecting from Microsoft SQL Server (milliseconds)	--	ulong	No	Agent Collector
Message (MESSAGE)	Character string of the error message when an attempt to connect to Microsoft SQL Server fails. This is blank when the connection is successful.	--	string(300)	No	Agent Collector
Record Time (RECORD_TIME)	Interval end time (GMT format)	--	time_t	No	Agent Collector
Record Type (INPUT_RECORD_TYPE)	Record type (always IA)	--	char(8)	No	Agent Collector
Start Time (START_TIME)	Interval start time (GMT format)	--	time_t	No	Agent Collector

Job History Detail (PD_JH)

Function

The Job History Detail (PD_JH) record indicates job history information incorporated into the Microsoft SQL Server schedule. One record is created for each case of job step history.

This is a multi-instance record.

Note:

- Collection of history information and monitoring of operations by alarms are performed for the jobs executed while PFM - Agent for Microsoft SQL Server is running. Collection of history information and monitoring of operations are not performed for the jobs executed while PFM - Agent for Microsoft SQL Server is stopped.
- Records whose Step ID field is 0 indicate job history, not job steps. The following table lists the fields and values for job history.

Field	Value
Step Name	(Job results)
Command	(Unknown)
Subsystem	(Unknown)

- The values of the Job Name, Command and Subsystem fields indicate the information at the time when the information is collected, not when the job is executed. Therefore, if the job step definition is changed after the job is executed, the field values might change as follows:

Operation		Value
When the job definition is changed	Delete the job	The job history can't collect.
	The job name is changed	New job name
When the job step definition is changed	Delete the job step	(Unknown)
	The job step definition or the order of executing job steps is changed	New job step definition

Default and changeable values

Item	Default value	Changeable
Collection Interval	300	Y
Collection Offset	0	Y
Log	No	Y
LOGIF	(Blank)	Y
Over 10 Sec Collection Time	No	N

ODBC key field

- PD_JH_COMPLETION_TIME
- PD_JH_INSTANCE_ID
- PD_JH_STEP_ID

Lifetime

From the time a job incorporated into the Microsoft SQL Server schedule is created until the time it is deleted

Record size

- Fixed part: 681 bytes
- Variable part: 8,631 bytes

Fields

View name (Manager name)	Description	Summary	Format	Delta	Data source
Command (COMMAND)	Command executed by a subcommand	--	string(8001)	No	msdb..sysjobsteps.command
Completion Time (COMPLETION_TIME)	Job or step completion time	--	time_t	No	msdb..sysjobhistory. (run_date+run_time +run_duration)
Instance ID (INSTANCE_ID)	Job history ID	--	long	No	msdb..sysjobhistory.instance_id
Job Name (JOB_NAME)	Job name	--	string(257)	No	msdb..sysjobs.name
Record Time (RECORD_TIME)	Interval end time (GMT format)	--	time_t	No	Agent Collector
Record Type (INPUT_RECORD_TYPE)	Record type (always JH)	--	char(8)	No	Agent Collector
Retries (RETRIES)	Job or step retry count	--	long	No	msdb..sysjobhistory.retries _attempted
Run Duration (RUN_DURATION)	Time required for job or step completion (in HHMMSS format)	--	long	No	msdb..sysjobhistory.run_d uration
Run Status (RUN_STATUS)	Execution status. The following values are valid: Failure, Success, Retry, Cancelled, or In progress.	--	string(15)	No	msdb..sysjobhistory.run_st atus
Start Time (START_TIME)	Interval start time (GMT format)	--	time_t	No	Agent Collector
Step ID (STEP_ID)	Step ID	--	long	No	msdb.. sysjobhistory.step_id
Step Name (STEP_NAME)	Step name	--	string(257)	No	msdb.. sysjobhistory.step_name
Subsystem (SUBSYSTEM)	Subsystem used for executing the step. Values such as LogReader and Sync are valid.	--	string(81)	No	msdb..sysjobsteps.subsyst em

Licensing Detail (PD_LIC)

Function

The Licensing Detail (PD_LIC) record indicates licensing information, such as the maximum number of Microsoft SQL Server connections allowed. Only one record is created.

Default and changeable values

Item	Default value	Changeable
Collection Interval	60	Y
Collection Offset	0	Y
Log	No	Y
LOGIF	(Blank)	Y
Over 10 Sec Collection Time	No	N

ODBC key field

None

Lifetime

From the time a Microsoft SQL Server instance is created until the time it is deleted

Record size

- Fixed part: 689 bytes
- Variable part: 0 bytes

Fields

View name (Manager name)	Description	Sum mary	Format	Delta	Data source	
					SQL Server version 2014 or earlier	SQL Server version 2016 or later
Record Time (RECORD_TIME)	Interval end time (GMT format)	--	time_t	No	Agent Collector	
Record Type (INPUT_RECOR D_TYPE)	Record type (always LIC)	--	char(8)	No	Agent Collector	
Session Count (CLIENT_COUN T)	Number of sessions connected to the Microsoft SQL Server during data collection	--	ulong	No	master.sysperfinfo	sys.dm_os_perform ance_counters
Session Limit (CLIENT_LIMIT)	Maximum number of sessions allowed to connect to the Microsoft SQL Server	--	ulong	No	@@max_connections	
Start Time (START_TIME)	Interval start time (GMT format)	--	time_t	No	Agent Collector	

Lock Detail (PD_LD)

Function

The Lock Detail (PD_LD) record indicates detailed information related to database locks. One record is created for each database lock. This is a multi-instance record.

If you collect the Lock Details (PD_LD) record when a large number of transactions or access locks have occurred in the Microsoft SQL Server, the following events might occur.

- Space in the Store database increases.
- Collection takes time, and until the collection has been completed, the collection of other records is skipped.
- A large amount of memory is consumed.

For example, when number of locks temporarily increases during backup of the SQL Server databases, you can set the upper limit by using the `LIMIT_PD_LD_NUMBER` item in the instance information to reduce system load.

For details about the `LIMIT_PD_LD_NUMBER` item, see [2.1.4\(2\)\(a\) Set up instance information](#).

To reduce system load, consider not collecting the Lock Detail (PD_LD) record, or substituting one of the following records that can collect information about the number of locks: Database Detail (PD_DD) record, Server Detail (PD) record, and Server Locks Detail (PD_LOCK) record.

Default and changeable values

Item	Default value	Changeable
Collection Interval	60	Y
Collection Offset	0	Y
Log	No	Y
LOGIF	(Blank)	Y
Over 10 Sec Collection Time	Yes	N

ODBC key field

- PD_LD_DB_NAME
- PD_LD_DBID
- PD_LD_SPID

Lifetime

From the start until release of a lock

Record size

- Fixed part: 681 bytes
- Variable part: 928 bytes

Fields

View name (Manager name)	Description	Summary	Format	Delta	Data source	
					SQL Server version 2014 or earlier	SQL Server version 2016 or later
Blocking Flag(BLOCKING)	This flag indicates whether or not the lock is a blocking lock. The following values are valid: 1 Blocking lock 0 Not a blocking lock	--	word	No	master..syslockinfo. req_status	sys.dm_tran_locks.r equest_status
DB Name (DB_NAME)	Database name related to lock resource	--	string(257)	No	master..syslockinfo. db_name(rsc_dbid)	db_name(sys.dm_tr an_locks.resource_d atabase_id)
DBID (DBID)	Database ID related to lock resource	--	ulong	No	master..syslockinfo. rsc_dbid	sys.dm_tran_locks.r esource_database_i d
Demand Flag (DEMAND)	This flag indicates whether or not the lock is a request lock. The following values are valid: 1 Request lock 0 Not a request lock	--	word	No	master..syslockinfo. rsc_type, master..syslockinfo.	sys.dm_tran_locks.r esource_type, sys.dm_tran_locks.r equest_mode
Lock Type (TYPE)	Lock type (lock request mode and lock resource type)	--	string(80)	No	master..syslockinfo. req_mode	sys.dm_tran_locks.r esource_type, sys.dm_tran_locks.r equest_mode
Orphan Flag (ORPHAN)	This flag indicates whether or not the lock is an isolated lock. The following values are valid: 1 Isolated lock 0 Not an isolated lock	--	word	No	master.sysprocesses	sys.dm_exec_sessio ns
Page # (PAGE)	Number of pages allocated to the lock resource	--	ulong	No	master..syslockinfo. rsc_text	sys.dm_tran_locks.r esource_description
Program (PROGRAM)	Name of the application program that is requesting the lock	--	string(257)	No	master.sysprocesses .program_name	sys.dm_exec_sessio ns.program_name
Record Time (RECORD_TIME)	Interval end time (GMT format)	--	time_t	No	Agent Collector	
Record Type (INPUT_RECOR D_TYPE)	Record type (always LD)	--	char(8)	No	Agent Collector	
SPID (SPID)	Process ID that is requesting the lock	--	word	No	master..syslockinfo. req_spid	sys.dm_tran_locks.r equest_session_id
Start Time	Interval start time (GMT format)	--	time_t	No	Agent Collector	

View name (Manager name)	Description	Summary	Format	Delta	Data source	
					SQL Server version 2014 or earlier	SQL Server version 2016 or later
(START_TIME)	Interval start time (GMT format)	--	time_t	No	Agent Collector	
Table (TABLE)	Table name if the lock resource is a table or row	--	string(257)	No	sys.all_objects.name in the row that satisfies the condition master.sys.dm_tran_locks.resource_associat ed_entity_id = master.sys.all_objects.object_id for each database.	
User (USER)	Logon name of the user who issued the command	--	string(61)	No	master..sysprocesses , master..syslogins	sys.dm_exec_sessio ns, sys.server_principal s

Procedure Cache Detail (PD_PCAC)

Function

The Procedure Cache Detail (PD_PCAC) record indicates information related to a procedure cache. Only one record is created.

A procedure cache is a memory area that stores the procedure that was used most recently. It is also used for creating a procedure and compiling a query.

Default and changeable values

Item	Default value	Changeable
Collection Interval	60	Y
Collection Offset	0	Y
Log	No	Y
LOGIF	(Blank)	Y
Over 10 Sec Collection Time	No	N

ODBC key field

None

Lifetime

From the time a Microsoft SQL Server instance starts until the time it stops

Record size

- Fixed part: 761 bytes
- Variable part: 0 bytes

Fields

View name (Manager name)	Description	Summary	Format	Delta	Data source
Max Proc Buffers Active % (MAX_PROCEDURE_BUFFERS_ACTIVE_PERCENT)	Maximum percentage of procedure cache slots that were used by the stored procedures being executed during the monitoring period	--	double	No	DBCC PROCCACHE
Max Proc Buffers Used % (MAX_PROCEDURE_BUFFERS_USED_PERCENT)	Maximum percentage of procedure cache slots that were used during the monitoring period	--	double	No	DBCC PROCCACHE
Max Proc Cache Active % (MAX_PROCEDURE_CACHE_ACTIVE_PERCENT)	Maximum percentage of procedure cache size that was used by the stored procedures being executed during the monitoring period	--	double	No	DBCC PROCCACHE

View name (Manager name)	Description	Summary	Format	Delta	Data source
Max Proc Cache Used % (MAX_PROCEDURE_CACHE_USED_PCT)	Maximum percentage of procedure cache size that was used during the monitoring period	--	double	No	DBCC PROCCACHE
Proc Buffers Active % (PROCEDURE_BUFFERS_ACTIVE_PCT)	Percentage of procedure cache slots that were used by the stored procedures being executed during the monitoring period	--	double	No	DBCC PROCCACHE
Proc Buffers Used % (PROCEDURE_BUFFERS_USED_PCT)	Percentage of procedure cache slots that were used during the monitoring period	--	double	No	DBCC PROCCACHE
Proc Cache Active % (PROCEDURE_CACHE_ACTIVE_PCT)	Percentage of procedure cache size that was used by the stored procedures being executed during the monitoring period	--	double	No	DBCC PROCCACHE
Proc Cache Size (PROCEDURE_CACHE_SIZE)	Total procedure cache size (in pages; 1 page equals 8 kilobytes)	--	double	No	DBCC PROCCACHE
Proc Cache Used % (PROCEDURE_CACHE_USED_PCT)	Percentage of procedure cache size that was used during the monitoring period	--	double	No	DBCC PROCCACHE
Record Time (RECORD_TIME)	Interval end time (GMT format)	--	time_t	No	Agent Collector
Record Type (INPUT_RECORD_TYPE)	Record type (always PCAC)	--	char(8)	No	Agent Collector
Start Time (START_TIME)	Interval start time (GMT format)	--	time_t	No	Agent Collector
Total Proc Buffers (TOTAL_PROCEDURE_BUFFERS)	Number of procedure cache slots inside the procedure cache (a fixed value based on the rate of procedure cache already allocated)	--	double	No	DBCC PROCCACHE

Process Detail (PD_PDET)

Function

The Process Detail (PD_PDET) record indicates detailed information on a particular database process, such as locks and I/O. One record is created for each database process. This is a multi-instance record.

Default and changeable values

Item	Default value	Changeable
Collection Interval	60	Y
Collection Offset	0	Y
Log	No	Y
LOGIF	(Blank)	Y
Over 10 Sec Collection Time	No	N

ODBC key field

PD_PDET_SPID

Lifetime

From the start until stop of a process

Record size

- Fixed part: 681 bytes
- Variable part: 1,174 bytes

Fields

View name (Manager name)	Description	Sum mary	Format	Delta	Data source	
					SQL Server version 2014 or earlier	SQL Server version 2016 or later
Blocked Processes (BLOCKING)	Number of processes blocked by the process	--	word	No	master..sysprocesses .blocked	sys.dm_exec_reques ts.blocking_session _id
Blocking Process (BLOCKED)	Process ID of a blocking process, if any	--	word	No	master..sysprocesses .blocked	sys.dm_exec_reques ts.blocking_session _id
CPU % (PERC_CPU)	CPU time being used by the process, as a percentage of the CPU time being used by all database processes This field cannot display correct value.	--	double	No	master..sysprocesses .cpu	sys.dm_exec_sessio ns.cpu_time, sys.dm_exec_reques ts.cpu_time
CPU Timeticks (CPU)	Cumulative CPU time of the process (in ticks) This field cannot display correct value.	--	ulong	No	master..sysprocesses .cpu	sys.dm_exec_sessio ns.cpu_time, sys.dm_exec_reques ts.cpu_time

View name (Manager name)	Description	Summary	Format	Delta	Data source	
					SQL Server version 2014 or earlier	SQL Server version 2016 or later
Command (COMMAND)	Name of the command executed	--	string(33)	No	master.sysprocesses .cmd	dm_exec_requests. Command
DB Name (DB_NAME)	Name of the database being used by the process at the time of record acquisition	--	string(257)	No	db_name(master.sys processes.dbid)	db_name(sys.dm_ex ec_sessions.databas e_id)
DBID (DBID)	Database ID being used by the process at the time of record acquisition	--	ulong	No	master.sysprocesses .dbid	sys.dm_exec_sessio ns.database_id
GID (GID)	This field is reserved and cannot be used.	--	--	--	--	--
Host (HOST)	Host computer name	--	string(257)	No	master.sysprocesses .hostname	sys.dm_exec_sessio ns.host_name
Host PID (HOST_PID)	Host process ID	--	long	No	master.sysprocesses .hostprocess	sys.dm_exec_sessio ns.host_process_id
Locks (LOCKS)	Number of locks being requested by the process at the time of record acquisition	--	long	No	master.syslockinfo. req_spid	sys.dm_tran_locks.r equest_session_id
Mem Usage (MEMUSAGE)	SQL Server version 2014 or earlier: Number of procedure cache pages allocated to the process (1 page equals 8 kilobytes) SQL Server version 2016 or later: Number of pages of memory used in the process	--	double	No	master.sysprocesses .memusage	sys.dm_exec_sessio ns.memory_usage
Physical I/O (PHYSICAL_IO)	Cumulative number of times the process executed read/write operations to disks	--	double	No	master.sysprocesses .physical_io	sys.dm_exec_sessio ns.reads, sys.dm_exec_sessio ns.writes, sys.dm_exec_reques ts.reads, sys.dm_exec_reques ts.writes
Program (PROGRAM)	Application program name	--	string(257)	No	master.sysprocesses .program_name	sys.dm_exec_sessio ns.program_name
Record Time (RECORD_TIME)	Interval end time (GMT format)	--	time_t	No	Agent Collector	
Record Type (INPUT_RECOR D_TYPE)	Record type (always PDET)	--	char(8)	No	Agent Collector	
SPID (SPID)	Process ID	--	word	No	master.sysprocesses .spid	sys.dm_exec_sessio ns.session_id
Start Time (START_TIME)	Interval start time (GMT format)	--	time_t	No	Agent Collector	

View name (Manager name)	Description	Summary	Format	Delta	Data source	
					SQL Server version 2014 or earlier	SQL Server version 2016 or later
Status (STATUS)	Process status	--	string(61)	No	master..sysprocesses. .status	sys.dm_exec_sessions. status
UID (UID)	SQL Server version 2014 or earlier: User ID of the user who executed the command SQL Server version 2016 or later: This is not available.	--	ulong	No	master..sysprocesses.uid	
User (USER)	SQL Server version 2014 or earlier: Logon name of the user who issued the command. If information cannot be obtained from the syslogins system table of Microsoft SQL Server, it is obtained from the sysprocesses system table. If the logon name used is 61 characters or longer, the part exceeding 61 characters is cut off. SQL Server version 2016 or later: If information cannot be obtained from the sys.server_principals system table, it is obtained from the dm_exec_sessions system table. If the logon name used is 61 characters or longer, the part exceeding 61 characters is cut off.	--	string(257)	No	master..sysprocesses. .sid, master..syslogins.na me or master..sysprocesses .sid, master..sysprocesses .loginame	sys.dm_exec_requests. session_id,sys.ser ver_principals.name or sys.dm_exec_sessions. security_id,sys.d m_exec_sessions.lo gin_name

Replication Published Database Overview (PI_RPDB)

Function

The Replication Published Database Overview (PI_RPDB) record indicates replication information related to database distribution transactions. One record is created for each database published in transaction replication.

This is a multi-instance record.

Default and changeable values

Item	Default value	Changeable
Collection Interval	60	Y
Collection Offset	0	Y
Log	No	Y
LOGIF	(Blank)	Y
Over 10 Sec Collection Time	No	N

ODBC key field

PI_RPDB_DB_NAME

Lifetime

From the time a publisher database is created until the time it is deleted

Record size

- Fixed part: 681 bytes
- Variable part: 313 bytes

Fields

View name (Manager name)	Description	Summary	Format	Delta	Data source
DB Name (DB_NAME)	Database name ^{#1}	COPY	string(257)	No	sp_replcounters.Database
Record Time (RECORD_TIME)	Interval end time (GMT format) ^{#1}	COPY	time_t	No	Agent Collector
Record Type (INPUT_RECORD_TYPE)	Record type (always RPDB) ^{#1}	COPY	char(8)	No	Agent Collector
Replicated Trans (REPLICATED_TRANSACTIONS)	Number of transactions inside the log that are waiting to be distributed to the distribution database ^{#2}	AVG	ulong	No	sp_replcounters.replicated transactions
Replicated Trans/sec (REPLICATED_TRANSACTIONS_PER_SEC)	Number of transactions per second distributed to the distribution database ^{#2}	AVG	double	No	sp_replcounters.replication rate trans/sec

View name (Manager name)	Description	Summary	Format	Delta	Data source
Replication Latency (REPLICATION_LATENCY)	The average latency (in seconds) from when a transaction is registered into a log to when the transaction is distributed ^{#2}	AVG	double	No	sp_replcounters.replication latency (sec)
Start Time (START_TIME)	Interval start time (GMT format) ^{#1}	COPY	time_t	No	Agent Collector

Replication Summary Detail (PD_RS)

Function

The Replication Summary Detail (PD_RS) record indicates a summary of database replication generated by Microsoft SQL Server. Only one record is created.

As indicated in the following table, the fields that can be acquired for this record differ depending on the database type.

Field	Database Type		
	Publisher	Distrbuter	Subscriber and Otehrs
Articles	Yes	No	No
Delivered Jobs	No	Yes	No
Delivery Latency	No	Yes	No
Delivery Rate	No	Yes	No
Publications	Yes	No	No
Subscriptions	Yes	No	No
None of the above	Yes	Yes	Yes

When a field cannot be acquired, the value is 0.

Default and changeable values

Item	Default value	Changeable
Collection Interval	60	Y
Collection Offset	0	Y
Log	No	Y
LOGIF	(Blank)	Y
Over 10 Sec Collection Time	No	N

ODBC key field

None

Lifetime

From the start until stop of a Microsoft SQL Server instance

Record size

- Fixed part: 709 bytes
- Variable part: 0 bytes

Fields

View name (Manager name)	Description	Summary	Format	Delta	Data source
Articles (ARTICLES)	Total number of articles published by the server	--	ulong	No	Each publication database's sysarticle
Delivered Jobs (DELIVERED_JOBS)	Number of distribution jobs delivered	--	ulong	No	Each distribution database's MSdistribution_history
Delivery Latency (DELIVERY_LATENCY)	Time between job receipt and delivery (in seconds)	--	ulong	No	Each distribution database's MSdistribution_history
Delivery Rate (DELIVERY_RATE)	Number of jobs executed per second in the last batch sent to the subscriber	--	double	No	Each distribution database's MSdistribution_history
Publications (PUBLICATIONS)	Total number of publications for the server	--	ulong	No	Each publication database's syspublications
Record Time (RECORD_TIME)	Interval end time (GMT format)	--	time_t	No	Agent Collector
Record Type (INPUT_RECORD_TYPE)	Record type (always RS)	--	char(8)	No	Agent Collector
Start Time (START_TIME)	Interval start time (GMT format)	--	time_t	No	Agent Collector
Subscriptions (SUBSCRIPTIONS)	Total number of subscriptions for the server	--	ulong	No	Each publication database's syssubscriptions

Server Detail (PD)

Function

The Server Detail (PD) record indicates detailed information on Microsoft SQL Server, such as I/O and locks. Only one record is created.

Default and changeable values

Item	Default value	Changeable
Collection Interval	60	Y
Collection Offset	0	Y
Log	No	Y
LOGIF	(Blank)	Y
Over 10 Sec Collection Time	No	N

ODBC key field

None

Lifetime

From the start until stop of a Microsoft SQL Server instance

Record size

- Fixed part: 1,303 bytes
- Variable part: 0 bytes

Fields

View name (Manager name)	Description	Sum mary	Format	Delta	Data source	
					SQL Server version 2014 or earlier	SQL Server version 2016 or later
Avg Cache Scan(CACHE_AV G_SCAN)	This field is reserved and cannot be used.	--	--	--	--	
Blocked Processes (BLOCKED)	Number of processes that are waiting because a process running on Microsoft SQL Server is locked	--	word	No	master..sysprocesses .blocked	sys.dm_exec_reques ts.blocking_session _id
Blocking Locks (BLOCKING)	Number of blocking locks	--	ulong	No	master..syslockinfo. req_status	sys.dm_tran_locks.r equest_status
Boot Time (BOOT_TIME)	This field is reserved and cannot be used.	--	time_t	No	Microsoft SQL Server error log	
CPU % (PERC_BUSY)	Percentage of time CPU is busy This field cannot display correct value.	--	double	No	CPU_BUSY / (CPU_BUSY + IDLE + IO_BUSY) * 100	

View name (Manager name)	Description	Summary	Format	Delta	Data source	
					SQL Server version 2014 or earlier	SQL Server version 2016 or later
CPU Time (CPU_TIME)	CPU busy time (in seconds and milliseconds) This field cannot display correct value.	--	utime	Yes	@@cpu_busy / 1000	
CPU Timeticks (CPU_BUSY)	CPU usage time (in ticks) This field cannot display correct value.	--	ulong	Yes	@@cpu_busy * 1000 / @@timeticks	
Cache Buffers Free (CACHE_FREE_BUFFERS)	Number of data cache buffers inside a free pool. For Microsoft SQL Server 2012 or later, this item is always 0.	--	word	No	master.sysperfinfo.free pages	sys.dm_os_performance_counters.free pages
Cache Hit % (CACHE_HIT_RATIO)	Rate at which data pages were found inside the data cache within an interval	--	double	No	master.sysperfinfo.buffer cache hit ratio / buffer cache hit ratio base * 100	sys.dm_os_performance_counters.buffer cache hit ratio / buffer cache hit ratio base * 100
Conns (CONNECTIONS)	Number of client connections	--	ulong	No	@@connections	
DSQuery (DS_QUERY)	Value of DSQUERY environment variable. Character string is truncated at 30 bytes.	--	string(31)	No	#4	
Database Count (DATABASES)	Database count	--	word	No	master.sysdatabases	sys.databases
Demand Locks (DEMAND)	Number of request locks	--	ulong	No	master.syslockinfo.rsc_type, master.syslockinfo.req_mode	sys.dm_tran_locks.resource_type, sys.dm_tran_locks.request_mode
Exclusive Intent Locks (EXCLUSIVE_INTENT)	Number of exclusive intent locks	--	ulong	No	master.syslockinfo.rsc_type, master.syslockinfo.req_mode	sys.dm_tran_locks.resource_type, sys.dm_tran_locks.request_mode
Exclusive Page Locks (EXCLUSIVE_PAGE)	Number of exclusive page locks	--	ulong	No	master.syslockinfo.rsc_type, master.syslockinfo.req_mode	sys.dm_tran_locks.resource_type, sys.dm_tran_locks.request_mode
Exclusive Table Locks (EXCLUSIVE_TABLE)	Number of exclusive table locks	--	ulong	No	master.syslockinfo.rsc_type, master.syslockinfo.req_mode	sys.dm_tran_locks.resource_type, sys.dm_tran_locks.request_mode
Host OS (OS)	OS under which Microsoft SQL Server is running. Data is truncated after 30 bytes.	--	string(31)	No	Value of registry-key HKEY_LOCAL_MACHINE \SOFTWARE \Microsoft \WindowsNT \CurrentVersion \ProductName	
Host Type (HOST_TYPE)	Type of machine on which Microsoft SQL Server is running.	--	string(31)	No	@@version	

View name (Manager name)	Description	Summary	Format	Delta	Data source	
					SQL Server version 2014 or earlier	SQL Server version 2016 or later
Host Type (HOST_TYPE)	Either of the following values is displayed: <ul style="list-style-type: none"> For the 32-bit and 64-bit (IPF) versions of Microsoft SQL Server: Intel For the 64-bit version of Microsoft SQL Server (x64): x64 	--	string(31)	No	@@version	
I/O % (PERC_IO)	Percentage of CPU time spent for I/O This field cannot display correct value.	--	double	No	$IO_BUSY / (CPU_BUSY + IDLE + IO_BUSY) * 100$	
I/O Time (IO_TIME)	Percentage of CPU time spent for I/O (in seconds and milliseconds) This field cannot display correct value.	--	utime	Yes	@@io_busy / 1000	
I/O Timeticks (IO_BUSY)	CPU I/O time (in ticks) This field cannot display correct value.	--	ulong	Yes	@@io_busy * 1000 / @@timeticks	
Idle % (PERC_IDLE)	Percentage of time CPU is idle This field cannot display correct value.	--	double	No	$IDLE / (CPU_BUSY + IDLE + IO_BUSY) * 100$	
Idle Time (IDLE_TIME)	Percentage of time CPU is idle (in seconds and milliseconds) This field cannot display correct value.	--	utime	Yes	@@idle / 1000	
Idle Timeticks (IDLE)	CPU idle time (in ticks) This field cannot display correct value.	--	ulong	Yes	@@idle * 1000 / @@timeticks	
Lazy Writes/sec (LAZY_WRITES_SEC)	Total number of pages flushed by Lazy Writer to a disk (1 page equals 8 kilobytes)	--	double	No	master..sysperfinfo.lazy writer buffers/sec	sys.dm_os_performance_counters.lazy writer buffers/sec
Locks (LOCKS)	Total number of locks	--	ulong	No	master..syslockinfo	sys.dm_tran_locks
Log Writes/sec (LOG_WRITES_SEC)	Total number of log pages written onto a disk	--	double	No	master..sysperfinfo.log flushes/sec	sys.dm_os_performance_counters.log flushes/sec
Max Cache Scan (CACHE_MAX_SCAN)	This field is reserved and cannot be used.	--	--	--	--	
Net Queue (NET_QUEUE)	This field is reserved and cannot be used.	--	--	--	--	
Net Reads/Sec (NET_READS_SEC)	This field is reserved and cannot be used.	--	--	--	--	

View name (Manager name)	Description	Summary	Format	Delta	Data source	
					SQL Server version 2014 or earlier	SQL Server version 2016 or later
Net Writes/Sec (NET_WRITES_SEC)	This field is reserved and cannot be used.	--	--	--	--	--
Other Processes (OTHER)	Number of processes of other types	--	word	No	master..sysprocesses. .status	sys.dm_exec_sessions. status
Page Reads/sec (PAGE_READS_SEC)	Total number of physical page read operations	--	double	No	master..sysperfnfo. page reads/sec	sys.dm_os_performance_counters. page reads/sec
Page Writes/sec (PAGE_WRITES_SEC)	Total number of physical page write operations	--	double	No	master..sysperfnfo. page writes/sec	sys.dm_os_performance_counters. page writes/sec
Pkt Errors (PACKET_ERRORS)	Number of packet errors	--	ulong	Yes	@@packet_errors	
Pkts Rcvd (PACK_RECEIVED)	Number of packets received	--	ulong	Yes	@@pack_received	
Pkts Sent (PACK_SENT)	Number of packets sent	--	ulong	Yes	@@pack_sent	
Process Count (PROCESSES)	Total number of processes	--	word	No	master..sysprocesses	sys.dm_exec_sessions
RA Pages Fetched (RA_PAGES_FETCHED)	Total number of pages prefetched into the cache by Read Ahead Manager	--	double	No	master..sysperfnfo. readahead pages/sec	sys.dm_os_performance_counters. readahead pages/sec
RA Pages Found (RA_PAGES_FOUND)	This field is reserved and cannot be used.	--	--	--	--	--
RA Reads/sec (RA_READS_SEC)	Total number of physical read operations executed by Read Ahead Manager	--	double	No	master..sysperfnfo. page reads/sec	sys.dm_os_performance_counters. page reads/sec
RA Slots Used (RA_SLOTS_USED)	This field is reserved and cannot be used.	--	--	--	--	--
Reads Pending (READS_PENDING)	This field is reserved and cannot be used.	--	--	--	--	--
Record Time (RECORD_TIME)	Interval end time (GMT format)	--	time_t	No	Agent Collector	
Record Type (INPUT_RECORD_TYPE)	Record type (always PD)	--	char(8)	No	Agent Collector	
Runnable Processes	Number of executable processes	--	word	No	master..sysprocesses. .status	sys.dm_exec_sessions. status

View name (Manager name)	Description	Summary	Format	Delta	Data source	
					SQL Server version 2014 or earlier	SQL Server version 2016 or later
(RUNNABLE)	Number of executable processes	--	word	No	master.sysprocesses. .status	sys.dm_exec_sessions. status
Running Processes (RUNNING)	Number of processes being executed	--	word	No	master.sysprocesses. .status	sys.dm_exec_sessions. status
Server Name (SERVER_NAME)	Name of machine on which Microsoft SQL Server is running	--	string(257)	No	@@servername	
Shared Intent Locks (SHARED_INTE NT)	Number of shared intent locks	--	ulong	No	master.syslockinfo. rsc_type, master.sys lockinfo.req_mode	sys.dm_tran_locks.r esource_type, sys.dm_tran_locks.r equest_mode
Shared Page Locks (SHARED_PAGE)	Number of shared page locks	--	ulong	No	master.syslockinfo. rsc_type, master.sys lockinfo.req_mode	sys.dm_tran_locks.r esource_type, sys.dm_tran_locks.r equest_mode
Shared Table Locks (SHARED_TABL E)	Number of shared table locks	--	ulong	No	master.syslockinfo. rsc_type, master.sys lockinfo.req_mode	sys.dm_tran_locks.r esource_type, sys.dm_tran_locks.r equest_mode
Sleeping Processes (SLEEPING)	Number of sleeping processes	--	word	No	master.sysprocesses. .status	sys.dm_exec_sessions. status
Start Time (START_TIME)	Interval start time (GMT format)	--	time_t	No	Agent Collector	
Timeticks (TIMETICKS)	Microseconds per tick	--	ulong	No	@@timeticks	
Total Errors (TOTAL_ERROR S)	Number of disk errors	--	ulong	Yes	@@total_errors	
Total Reads (TOTAL_READ)	Number of disk read operations	--	ulong	Yes	@@total_read	
Total Writes (TOTAL_WRITE)	Number of disk write operations	--	ulong	Yes	@@total_write	
Trans/sec (TRANS_SEC)	Total number of Transact-SQL command batches executed	--	double	No	master.sysperfinfo. batch requests/sec	sys.dm_os_perform ance_counters.batch requests/sec
Update Page Locks (UPDATE_PAGE)	Number of update page locks	--	ulong	No	master.syslockinfo. rsc_type, master.sys lockinfo.req_mode	sys.dm_tran_locks.r esource_type, sys.dm_tran_locks.r equest_mode
Version (SERVER_VERSI ON)	Microsoft SQL Server version	--	string(20)	No	SERVERPROPERTY('productversion')	
Writes Pending	This field is reserved and cannot be used.	--	--	--	--	

View name (Manager name)	Description	Summary	Format	Delta	Data source	
					SQL Server version 2014 or earlier	SQL Server version 2016 or later
(WRITES_PENDING)	This field is reserved and cannot be used.	--	--	--	--	--

#4

N/A is always displayed.

Server Locks Detail (PD_LOCK)

Function

The Server Locks Detail (PD_LOCK) record indicates information related to Microsoft SQL Server locks. Only one record is created.

Default and changeable values

Item	Default value	Changeable
Collection Interval	60	Y
Collection Offset	0	Y
Log	No	Y
LOGIF	(Blank)	Y
Over 10 Sec Collection Time	No	N

ODBC key field

None

Lifetime

From the start until stop of a Microsoft SQL Server instance

Record size

- Fixed part: 757 bytes
- Variable part: 0 bytes

Fields

View name (Manager name)	Description	Sum mary	Format	Delta	Data source	
					SQL Server version 2014 or earlier	SQL Server version 2016 or later
Exclusive Extent Locks(EXTENT_ LOCKS_EXCLUS IVE)	Number of exclusive extent locks	--	ulong	No	master..syslockinfo. rsc_type, master..syslockinfo. req_mode	sys.dm_tran_locks.r esource_type, sys.dm_tran_locks.r equest_mode
Exclusive Intent Locks (INTENT_LOCK S_EXCLUSIVE)	Number of exclusive intent locks	--	ulong	No	master..syslockinfo. rsc_type, master..syslockinfo. req_mode	sys.dm_tran_locks.r esource_type, sys.dm_tran_locks.r equest_mode
Exclusive Page Locks (PAGE_LOCKS_ EXCLUSIVE)	Number of exclusive page locks	--	ulong	No	master..syslockinfo. rsc_type, master..syslockinfo. req_mode	sys.dm_tran_locks.r esource_type, sys.dm_tran_locks.r equest_mode
Exclusive Table Locks (TABLE_LOCKS_ EXCLUSIVE)	Number of exclusive table locks	--	ulong	No	master..syslockinfo. rsc_type, master..syslockinfo. req_mode	sys.dm_tran_locks.r esource_type, sys.dm_tran_locks.r equest_mode

View name (Manager name)	Description	Summary	Format	Delta	Data source	
					SQL Server version 2014 or earlier	SQL Server version 2016 or later
Max Users Blocked (MAX_USERS_BLOCKED)	Maximum number of users who were blocked by other users during the monitored period	--	ulong	No	master.sysprocesses.blocked	sys.dm_exec_requests.blocking_session_id
Record Time (RECORD_TIME)	Interval end time (GMT format)	--	time_t	No	Agent Collector	
Record Type (INPUT_RECORD_TYPE)	Record type (always LOCK)	--	char(8)	No	Agent Collector	
Shared Intent Locks (INTENT_LOCKS_SHARED)	Number of shared intent locks	--	ulong	No	master.syslockinfo.rsc_type, master.syslockinfo.req_mode	sys.dm_tran_locks.resource_type, sys.dm_tran_locks.request_mode
Shared Page Locks (PAGE_LOCKS_SHARED)	Number of shared page locks	--	ulong	No	master.syslockinfo.rsc_type, master.syslockinfo.req_mode	sys.dm_tran_locks.resource_type, sys.dm_tran_locks.request_mode
Shared Table Locks (TABLE_LOCKS_SHARED)	Number of shared table locks	--	ulong	No	master.syslockinfo.rsc_type, master.syslockinfo.req_mode	sys.dm_tran_locks.resource_type, sys.dm_tran_locks.request_mode
Start Time (START_TIME)	Interval start time (GMT format)	--	time_t	No	Agent Collector	
Total Blocking Locks (TOTAL_BLOCKING_LOCKS)	Number of locks that are blocking other processes	--	ulong	No	master.syslockinfo.rsc_type, master.syslockinfo.req_mode	sys.dm_tran_locks.resource_type, sys.dm_tran_locks.request_mode
Total Exclusive Locks (TOTAL_EXCLUSIVE_LOCKS)	Total number of exclusive locks	--	ulong	No	master.syslockinfo.rsc_type, master.syslockinfo.req_mode	sys.dm_tran_locks.resource_type, sys.dm_tran_locks.request_mode
Total Extent Locks (EXTENT_LOCKS_TOTAL)	Total number of extent locks	--	ulong	No	master.syslockinfo.rsc_type, master.syslockinfo.req_mode	sys.dm_tran_locks.resource_type, sys.dm_tran_locks.request_mode
Total Intent Locks (INTENT_LOCKS_TOTAL)	Total number of intent locks	--	ulong	No	master.syslockinfo.rsc_type, master.syslockinfo.req_mode	sys.dm_tran_locks.resource_type, sys.dm_tran_locks.request_mode
Total Locks (TOTAL_LOCKS)	Total number of locks being used by Microsoft SQL Server	--	ulong	No	master.syslockinfo.rsc_type, master.syslockinfo.req_mode	sys.dm_tran_locks.resource_type, sys.dm_tran_locks.request_mode
Total Page Locks (PAGE_LOCKS_TOTAL)	Total number of page locks	--	ulong	No	master.syslockinfo.rsc_type, master.syslockinfo.req_mode	sys.dm_tran_locks.resource_type, sys.dm_tran_locks.request_mode

View name (Manager name)	Description	Summary	Format	Delta	Data source	
					SQL Server version 2014 or earlier	SQL Server version 2016 or later
Total Shared Locks (TOTAL_SHARED_LOCKS)	Total number of shared locks	--	ulong	No	master..syslockinfo. rsc_type, master..syslockinfo. req_mode	sys.dm_tran_locks.r esource_type, sys.dm_tran_locks.r equest_mode
Total Table Locks (TABLE_LOCKS_TOTAL)	Total number of table locks	--	ulong	No	master..syslockinfo. rsc_type, master..syslockinfo. req_mode	sys.dm_tran_locks.r esource_type, sys.dm_tran_locks.r equest_mode
Update Extent Locks (EXTENT_LOCKS_UPDATE)	Number of update extent locks	--	ulong	No	master..syslockinfo. rsc_type, master..syslockinfo. req_mode	sys.dm_tran_locks.r esource_type, sys.dm_tran_locks.r equest_mode
Update Page Locks (PAGE_LOCKS_UPDATE)	Number of update page locks	--	ulong	No	master..syslockinfo. rsc_type, master..syslockinfo. req_mode	sys.dm_tran_locks.r esource_type, sys.dm_tran_locks.r equest_mode
Users Blocked (USERS_BLOCKED)	Number of users who are blocked by other users	--	ulong	No	master..sysprocesses .blocked	sys.dm_exec_requests. blocking_session _id

Server Overview (PI_SERV)

Function

The Server Overview (PI_SERV) record indicates overall information related to Microsoft SQL Server, such as rate of cache hits and I/O. Only one record is created.

Default and changeable values

Item	Default value	Changeable
Collection Interval	60	Y
Collection Offset	0	Y
Log	No	Y
LOGIF	(Blank)	Y
Over 10 Sec Collection Time	No	N

ODBC key field

None

Lifetime

From the start until stop of a Microsoft SQL Server instance

Record size

- Fixed part: 1,109 bytes
- Variable part: 0 bytes

Fields

View name (Manager name)	Description	Summary	Format	Delta	Data source	
					SQL Server version 2014 or earlier	SQL Server version 2016 or later
Avg Cache Scan (CACHE_AVG_FREE_PAGE_SCAN)	This field is reserved and cannot be used.	AVG	--	--	--	
Avg Latch Waits Time (AVG_LATCH_WAIT_TIME)	Average latch wait time (milliseconds) ^{#2}	AVG	double	No	LATCH_WAIT_TIME / LATCH_WAIT	
Cache Buffers Free (CACHE_NUMBER_OF_FREE_BUFFERS)	Number of data cache buffers inside a free pool at the time of data collection. For Microsoft SQL Server 2012 or later, this item is always 0. ^{#2}	AVG	ulong	No	master..sysperfnf.free pages	sys.dm_os_performance_counters.free pages
Cache Hit %	Rate at which data pages were found inside the data cache ^{#2}	AVG	double	No	master..sysperfnf.buffer cache hit	sys.dm_os_performance_counters.buffe

View name (Manager name)	Description	Summary	Format	Delta	Data source	
					SQL Server version 2014 or earlier	SQL Server version 2016 or later
(CACHE_HIT_RATIO)	Rate at which data pages were found inside the data cache ^{#2}	AVG	double	No	ratio / buffer cache hit ratio base * 100	r cache hit ratio / buffer cache hit ratio base * 100
Command Queue Length (NET_COMMAND_QUEUE_LENGTH)	This field is reserved and cannot be used.	AVG	--	--	--	--
Compilations (COMPILE)	Total number of SQL compilations ^{#2}	HI	double	No	master..sysperfnfo.sql compilations/sec	sys.dm_os_performance_counters.sql compilations/sec
Compilations % (COMPILE_RATIO)	Ratio of SQL compilation processes to Transact-SQL command batches executed ^{#2}	AVG	double	No	COMPILE / IO_TRANSACTIONS_PER_SEC * 100	
Full Scans (FULL_SCAN)	Total number of full scans (base table full scan or full index full scan) ^{#2}	HI	double	No	master..sysperfnfo.full scans/sec	sys.dm_os_performance_counters.full scans/sec
Index Searches (INDEX_SEARCH)	Total number of index searches ^{#2}	HI	double	No	master..sysperfnfo.index searches/sec	sys.dm_os_performance_counters.index searches/sec
Index Searches Efficiency (INDEX EFFICIENCY)	Number of index scans executed during one full scan ^{#2}	AVG	double	No	INDEX_SEARCH / FULL_SCAN	
Latch Waits (LATCH_WAIT)	Total number of latch waits ^{#2}	HI	double	No	master..sysperfnfo.latch waits/sec	sys.dm_os_performance_counters.latch waits/sec
Latch Wait Time (LATCH_WAIT_TIME)	Total latch wait time (milliseconds) ^{#2}	HI	double	No	master..sysperfnfo.total latch wait time (ms)	sys.dm_os_performance_counters.total latch wait time (ms)
Lazy Writes/sec (IO_LAZY_WRITES_PER_SEC)	Total number of pages flushed by Lazy Writer to a disk (1 page equals 8 kilobytes) ^{#2}	AVG	double	No	master..sysperfnfo.Lazy writes/sec	sys.dm_os_performance_counters.lazy writer buffers/sec
Log Writes/sec (IO_LOG_WRITES_PER_SEC)	Total number of log pages physically written onto a disk ^{#2}	AVG	double	No	master..sysperfnfo.log flushes/sec	sys.dm_os_performance_counters.log flushes/sec
Max Cache Scan (CACHE_MAX_FREE_PAGE_SCAN)	This field is reserved and cannot be used.	HI	--	--	--	--
Max Tempdb Space Used Mbytes (MAX_TEMPDB_SPACE_USED_MB)	Maximum value of the space used in tempdb within an interval (in megabytes)	HI	double	No	master..sysperfnfo.data file(s) size (kb) / 1024	sys.dm_os_performance_counters.data file(s) size (kb) / 1024

View name (Manager name)	Description	Summary	Format	Delta	Data source	
					SQL Server version 2014 or earlier	SQL Server version 2016 or later
Max Users Conn'd (MAX_USERS_CONNECTED)	Maximum number of user connections established within an interval	HI	ulong	No	master.sysperfinfo. user connections	sys.dm_os_performance_counters.User connections
Net Reads/sec (NET_NETWORK_READS_PER_SEC)	This field is reserved and cannot be used.	AVG	--	--	--	
Net Writes/sec (NET_NETWORK_WRITES_PER_SEC)	This field is reserved and cannot be used.	AVG	--	--	--	
Page Reads/sec (IO_PAGE_READS_PER_SEC)	Total number of physical page read operations executed ^{#2}	AVG	double	No	master.sysperfinfo. page reads/sec	sys.dm_os_performance_counters.page reads/sec
Page Writes/sec (IO_PAGE_WRITES_PER_SEC)	Total number of physical page write operations executed ^{#2}	AVG	double	No	master.sysperfinfo. page writes/sec	sys.dm_os_performance_counters.page writes/sec
RA Pages Fetched into Cache/sec (RA_PAGES_FETCHED_INTO_CACHE_PER_SEC)	Total number of pages prefetched into the cache by Read Ahead Manager ^{#2}	AVG	double	No	master.sysperfinfo. readahead pages/sec	sys.dm_os_performance_counters.readahead pages/sec
RA Pages Found in Cache/sec (RA_PAGES_FOUND_IN_CACHE_PER_SEC)	This field is reserved and cannot be used.	AVG	--	--	--	
RA Physical Reads/sec (RA_PHYSICAL_READS_PER_SEC)	Total number of physical read operations issued by Read Ahead Manager. (A single read operation involves 8 pages, each of which is 8 kilobytes) ^{#2}	AVG	double	No	master.sysperfinfo. page reads/sec	sys.dm_os_performance_counters.page reads/sec
RA Slots Used (RA_SLOTS_USED)	This field is reserved and cannot be used.	COPY	--	--	--	
Reads Pending (IO_OUTSTANDING_READS)	This field is reserved and cannot be used.	AVG	--	--	--	
Record Time (RECORD_TIME)	Interval end time (GMT format) ^{#1}	COPY	time_t	No	Agent Collector	
Record Type (INPUT_RECORD_TYPE)	Record type (always SERV) ^{#1}	COPY	char(8)	No	Agent Collector	
Start Time (START_TIME)	Interval start time (GMT format) ^{#1}	COPY	time_t	No	Agent Collector	

View name (Manager name)	Description	Summary	Format	Delta	Data source	
					SQL Server version 2014 or earlier	SQL Server version 2016 or later
Trans/sec (IO_TRANSACTI ONS_PER_SEC)	Total number of Transact-SQL command batches executed ^{#2}	AVG	double	No	master..sysperfinfo. batch requests/sec	sys.dm_os_perform ance_counters.batch requests/sec
User Conns (USER_CONNEC TIONS)	Number of client connections ^{#1}	COP Y	ulong	No	master..sysperfinfo. user connections	sys.dm_os_perform ance_counters.User connections
Writes Pending (IO_OUTSTANDI NG_WRITES)	This field is reserved and cannot be used.	AVG	--	--	--	--

Server Overview 2 (PI_SRV2)

Function

The Server Overview 2(PI_SRV2) record indicates overall information related to Microsoft SQL Server, such as rate of cache hits and I/O. The Server Overview 2(PI_SRV2) record acquires from the Microsoft SQL Server the values of the fields which store the cumulative values for "/sec" counters and uses those values to calculate the per-sec value. Only one record is created.

Default and changeable values

Item	Default value	Changeable
Collection Interval	60	Y
Collection Offset	0	Y
Log	No	Y
LOGIF	(Blank)	Y
Over 10 Sec Collection Time	No	N

ODBC key field

None

Lifetime

From the start until stop of a Microsoft SQL Server instance

Record size

- Fixed part: 1,169 bytes
- Variable part: 0 bytes

Fields

View name (Manager name)	Description	Summary	Format	Delta	Data source	
					SQL Server version 2014 or earlier	SQL Server version 2016 or later
Avg Cache Scan (CACHE_AVG_FREE_PAGE_SCAN)	This field is reserved and cannot be used.	AVG	--	--	--	
Avg Latch Waits Time (AVG_LATCH_WAIT_TIME)	Average latch wait time (milliseconds) ^{#2}	AVG	double	Yes ^{#5}	LATCH_WAIT_TIME / LATCH_WAIT_SEC	
Cache Buffers Free (CACHE_NUMBER_OF_FREE_BUFFERS)	Number of data cache buffers inside a free pool at the time of data collection. For Microsoft SQL Server 2012 or later, this item is always 0. ^{#2}	AVG	ulong	No	master..sysperfnf.free pages	sys.dm_os_performance_counters.free pages

View name (Manager name)	Description	Summary	Format	Delta	Data source	
					SQL Server version 2014 or earlier	SQL Server version 2016 or later
Cache Hit % (CACHE_HIT_RATIO)	Rate at which data pages were found inside the data cache ^{#2}	AVG	double	No	master..sysperfinfo. buffer cache hit ratio / buffer cache hit ratio base * 100	sys.dm_os_perform ance_counters.buffe r cache hit ratio / buffer cache hit ratio base * 100
Command Queue Length (NET_COMMAND_QUEUE_LENGTH)	This field is reserved and cannot be used.	AVG	--	--	--	--
Compilations/sec (COMPILE_SEC)	Number of SQL compilations per second ^{#2}	AVG	double	Yes ^{#5}	master..sysperfinfo.s ql compilations/sec	sys.dm_os_perform ance_counters.sql compilations/sec
Compilations % (COMPILE_RATIO)	Ratio of SQL compilation processes to Transact-SQL command batches executed ^{#2}	AVG	double	Yes ^{#5}	COMPILE_SEC / IO_TRANSACTIONS_PER_SEC * 100	
Full Scans/sec (FULL_SCAN_SEC)	Number of full scans per second (base table full scan or full index full scan) ^{#2}	AVG	double	Yes ^{#5}	master..sysperfinfo.f ull scans/sec	sys.dm_os_perform ance_counters.full scans/sec
Index Searches/sec (INDEX_SEARCH_SEC)	Number of index searches per second ^{#2}	AVG	double	Yes ^{#5}	master..sysperfinfo.i ndex searches/sec	sys.dm_os_perform ance_counters.index searches/sec
Index Searches Efficiency (INDEX EFFICIENCY)	Number of index scans executed during one full scan ^{#2}	AVG	double	Yes ^{#5}	INDEX_SEARCH_SEC / FULL_SCAN_SEC	
Latch Waits/sec (LATCH_WAIT_SEC)	Number of latch waits per second ^{#2}	AVG	double	Yes ^{#5}	master..sysperfinfo.l atch waits/sec	sys.dm_os_perform ance_counters.latch waits/sec
Latch Wait Time (LATCH_WAIT_TIME)	Latch wait time within an interval (milliseconds) ^{#2}	AVG	double	Yes ^{#5}	master..sysperfinfo.t otal latch wait time (ms)	sys.dm_os_perform ance_counters.total latch wait time (ms)
Lazy Writes/sec (IO_LAZY_WRITES_PER_SEC)	Number of pages per second flushed by Lazy Writer to a disk within an interval (1 page equals 8 kilobytes) ^{#2}	AVG	double	Yes ^{#5}	master..sysperfinfo. Lazy writes/sec	sys.dm_os_perform ance_counters.lazy writer buffers/sec
Log Writes/sec (IO_LOG_WRITES_PER_SEC)	Number of log pages per second physically written onto a disk within an interval ^{#2}	AVG	double	Yes ^{#5}	master..sysperfinfo.l og flushes/sec	sys.dm_os_perform ance_counters.log flushes/sec
Max Cache Scan (CACHE_MAX_FREE_PAGE_SCAN)	This field is reserved and cannot be used.	HI	--	--	--	--
Max Tempdb Space Used Mbytes	Maximum value of the space used in tempdb within an interval (in megabytes)	HI	double	No	master..sysperfinfo. data file(s) size (kb) / 1024	sys.dm_os_perform ance_counters.data file(s) size (kb) / 1024

View name (Manager name)	Description	Summary	Format	Delta	Data source	
					SQL Server version 2014 or earlier	SQL Server version 2016 or later
(MAX_TEMPDB_SPACE_USED_MB)	Maximum value of the space used in tempdb within an interval (in megabytes)	HI	double	No	master..sysperfinfo. data file(s) size (kb) / 1024	sys.dm_os_performance_counters.data file(s) size (kb) / 1024
Max Users Conn'd (MAX_USERS_CONNECTED)	Maximum number of user connections established within an interval	HI	ulong	No	master..sysperfinfo. user connections	sys.dm_os_performance_counters.User connections
Net Reads/sec (NET_NETWORK_READS_PER_SEC)	This field is reserved and cannot be used.	AVG	--	--	--	--
Net Writes/sec (NET_NETWORK_WRITES_PER_SEC)	This field is reserved and cannot be used.	AVG	--	--	--	--
Page Reads/sec (IO_PAGE_READS_PER_SEC)	Number of physical pages read per second within an interval ^{#2}	AVG	double	Yes ^{#5}	master..sysperfinfo. page reads/sec	sys.dm_os_performance_counters.page reads/sec
Page Writes/sec (IO_PAGE_WRITES_PER_SEC)	Number of physical pages written per second within an interval ^{#2}	AVG	double	Yes ^{#5}	master..sysperfinfo. page writes/sec	sys.dm_os_performance_counters.page writes/sec
RA Pages Fetched into Cache/sec (RA_PAGES_FETCHED_INTO_CACHE_PER_SEC)	Number of pages per second prefetched into the cache by Read Ahead Manager within an interval ^{#2}	AVG	double	Yes ^{#5}	master..sysperfinfo.r eadahead pages/sec	sys.dm_os_performance_counters.reada head pages/sec
RA Pages Found in Cache/sec (RA_PAGES_FOUND_IN_CACHE_PER_SEC)	This field is reserved and cannot be used.	AVG	--	--	--	--
RA Physical Reads/sec (RA_PHYSICAL_READS_PER_SEC)	Number of physical read operations per second issued by Read Ahead Manager within an interval. (A single read operation involves 8 pages, each of which is 8 kilobytes) ^{#2}	AVG	double	Yes ^{#5}	master..sysperfinfo. page reads/sec	sys.dm_os_performance_counters.page reads/sec
RA Slots Used (RA_SLOTS_USED)	This field is reserved and cannot be used.	COPY	--	--	--	--
Reads Pending (IO_OUTSTANDING_READS)	This field is reserved and cannot be used.	AVG	--	--	--	--
Record Time (RECORD_TIME)	Interval end time (GMT format) ^{#1}	COPY	time_t	No	Agent Collector	
Record Type	Record type (always SERV) ^{#1}	COPY	char(8)	No	Agent Collector	

View name (Manager name)	Description	Summary	Format	Delta	Data source	
					SQL Server version 2014 or earlier	SQL Server version 2016 or later
(INPUT_RECORD_TYPE)	Record type (always SERV) ^{#1}	COPY	char(8)	No	Agent Collector	
Start Time (START_TIME)	Interval start time (GMT format) ^{#1}	COPY	time_t	No	Agent Collector	
Trans/sec (IO_TRANSACTI ONS_PER_SEC)	Number of Transact-SQL command batches per second executed within an interval ^{#2}	AVG	double	Yes ^{#5}	master..sysperfinfo. batch requests/sec	sys.dm_os_perform ance_counters.batch requests/sec
User Conns (USER_CONN CTIONS)	Number of client connections ^{#1}	COPY	ulong	No	master..sysperfinfo. user connections	sys.dm_os_perform ance_counters.User connections
Writes Pending (IO_OUTSTANDI NG_WRITES)	This field is reserved and cannot be used.	AVG	--	--	--	

#5

The delta is calculated based on the changed amount of data acquired from SQL Server data base.

Server Space Detail (PD_SS)

Function

The Server Space Detail (PD_SS) record indicates information related to the size of the disk space used by Microsoft SQL Server. One record is created for each Microsoft SQL Server instance.

Default and changeable values

Item	Default value	Changeable
Collection Interval	60	Y
Collection Offset	0	Y
Log	No	Y
LOGIF	(Blank)	Y
Over 10 Sec Collection Time	No	N

ODBC key field

None

Lifetime

From the creation until deletion of an instance

Record size

- Fixed part: 753 bytes
- Variable part: 0 bytes

Fields

View name (Manager name)	Description	Summary	Format	Delta	Data source	
					SQL Server version 2014 or earlier	SQL Server version 2016 or later
DB Size (SIZE)	Size of the entire database (in megabytes)	--	double	No	dbo.sysfiles	sys.database_files
Data Mbytes (DATA)	Size of the database being used (in megabytes)	--	double	No	sys.partitions, sys.allocation_units, sys.internal_tables	
Free % (PERC_FREE)	Free space as a percentage of the size of the entire database, including data files and transaction log files	--	double	No	dbo.sysfiles, sys.partitions, sys.allocation_units, sys.internal_tables	sys.database_files, sys.partitions, sys.allocation_units, sys.internal_tables
Free Mbytes (FREE_SPACE)	Size of the free space in the area allocated to the entire database, including data files and transaction log files (in megabytes)	--	double	No	dbo.sysfiles, sys.partitions, sys.allocation_units, sys.internal_tables	sys.database_files, sys.partitions, sys.allocation_units, sys.internal_tables
Index Mbytes (IDX)	Size of index space being used (in megabytes)	--	double	No	sys.partitions, sys.allocation_units, sys.internal_tables	

View name (Manager name)	Description	Summary	Format	Delta	Data source	
					SQL Server version 2014 or earlier	SQL Server version 2016 or later
Log Mbytes (LOG)	Size of log space being used (in megabytes)	--	double	No	DBCC SQLPERF(LOGSPACE)	
Record Time (RECORD_TIME)	Interval end time (GMT format)	--	time_t	No	Agent Collector	
Record Type (INPUT_RECORD_TYPE)	Record type (always SS)	--	char(8)	No	Agent Collector	
Rsvd Mbytes (RESERVED)	Size of space already allocated (in megabytes)	--	double	No	sys.partitions, sys.allocation_units, sys.internal_tables	
Start Time (START_TIME)	Interval start time (GMT format)	--	time_t	No	Agent Collector	
Unused % (PERC_USED)	Unused space as a percentage of total allocated space	--	double	No	sys.partitions, sys.allocation_units, sys.internal_tables	
Unused Mbytes (UNUSED)	Size of allocated but unused space (in megabytes)	--	double	No	sys.partitions, sys.allocation_units, sys.internal_tables	

Server Space Interval (PI_SI)

Function

The Server Space Interval (PI_SI) record indicates interval information related to the size of the disk space used by Microsoft SQL Server. One record is created for each Microsoft SQL Server instance.

Default and changeable values

Item	Default value	Changeable
Collection Interval	60	Y
Collection Offset	0	Y
Log	No	Y
LOGIF	(Blank)	Y
Over 10 Sec Collection Time	No	N

ODBC key field

None

Lifetime

From the creation until deletion of an instance

Record size

- Fixed part: 777 bytes
- Variable part: 0 bytes

Fields

View name (Manager name)	Description	Summary	Format	Delta	Data source	
					SQL Server version 2014 or earlier	SQL Server version 2016 or later
DB Size (SIZE)	Size of the entire database (in megabytes) ^{#1}	COPY	double	No	dbo.sysfiles	sys.database_files
Data Mbytes (DATA)	Size of database being used (in megabytes) ^{#1}	COPY	double	No	sys.partitions, sys.allocation_units, sys.internal_tables	
Free % (PERC_FREE)	Free space as a percentage of the size of the entire database, including data files and transaction log files ^{#2}	AVG	double	No	dbo.sysfiles, sys.partitions, sys.allocation_units, sys.internal_tables	sys.database_files, sys.partitions, sys.allocation_units, sys.internal_tables
Free Mbytes (FREE_SPACE)	Size of the free space in the area allocated to the entire database, including data files and transaction log files (in megabytes)	LO	double	No	dbo.sysfiles, sys.partitions, sys.allocation_units, sys.internal_tables	sys.database_files, sys.partitions, sys.allocation_units, sys.internal_tables
Index Mbytes (IDX)	Size of index space being used (in megabytes) ^{#1}	COPY	double	No	sys.partitions, sys.allocation_units, sys.internal_tables	

View name (Manager name)	Description	Summary	Format	Delta	Data source	
					SQL Server version 2014 or earlier	SQL Server version 2016 or later
Log Mbytes (LOG)	Size of log space being used (in megabytes) ^{#1}	COPY	double	No	DBCC SQLPERF(LOGSPACE)	
Record Time (RECORD_TIME)	Interval end time (GMT format) ^{#1}	COPY	time_t	No	Agent Collector	
Record Type (INPUT_RECORD_TYPE)	Record type (always SI) ^{#1}	COPY	char(8)	No	Agent Collector	
Rsvd Mbytes (RESERVED)	Size of space already allocated (in megabytes) ^{#1}	COPY	double	No	sys.partitions, sys.allocation_units, sys.internal_tables	
Start Time (START_TIME)	Interval start time (GMT format) ^{#1}	COPY	time_t	No	Agent Collector	
Unused % (PERC_USED)	Unused space as a percentage of total allocated space ^{#2}	AVG	double	No	sys.partitions, sys.allocation_units, sys.internal_tables	
Unused Mbytes (UNUSED)	Size of allocated but unused space (in megabytes) ^{#1}	COPY	double	No	sys.partitions, sys.allocation_units, sys.internal_tables	

SQL Text (PD_SQL)

Function

The SQL Text (PD_SQL) record indicates the execution information on the last query issued by a process. The number of records created equals the number of queries that the process last issued. This is a multi-instance record.

The SQL Plan and SQL Text fields of this record use a `DBCC INPUTBUFFER` statement for acquiring data. To execute this statement, you must have a fixed server role `sysadmin` member account for Microsoft SQL Server.

Because this record is available only in real-time, it cannot be displayed in the Properties window of Performance Reporter by clicking an Agent icon on the Agents window and then clicking the Properties method.

Notes:

In a Simplified-Chinese Windows environment, when an SQL statement includes a non- GBK character, the value of the SQL Plan field cannot be collected correctly. Non- GBK characters appear as ? or other unreadable characters.

ODBC key field

PD_SQL_SPID

Lifetime

None

Record size

- Fixed part: 681 bytes
- Variable part: 30,464 bytes

Fields

View name (Manager name)	Description	Summary	Format	Delta	Data source	
					SQL Server version 2014 or earlier	SQL Server version 2016 or later
Command (COMMAND)	The last command executed	--	string(33)	No	master..sysprocesses .cmd	dm_exec_requests. Command
Record Time (RECORD_TIME)	Interval end time (GMT format)	--	time_t	No	Agent Collector	
Record Type (INPUT_RECORD_TYPE)	Record type (always SQL)	--	char(8)	No	Agent Collector	
SID (SID)	User's security ID	--	string(171)	No	master..syslogins.sid	sys.databases.owner _sid
SPID (SPID)	Process ID	--	word	No	master..sysprocesses .spid	sys.dm_exec_sessions. session_id
SQL Plan (SQL_PLAN)	Displays the execution information for an SQL statement.	--	string(30001)	No	Result obtained when SET SHOWPLAN_ALL ON and SET NOEXEC ON are specified for executing the SQL Text statement	

View name (Manager name)	Description	Summary	Format	Delta	Data source	
					SQL Server version 2014 or earlier	SQL Server version 2016 or later
SQL Text (SQL_TEXT)	Displays the last statement sent by this process.	--	string(30001)	No	DBCC INPUTBUFFER(m aster..sysprocesses.s pid)	DBCC INPUTBUFFER(sy s.dm_exec_sessions .session_id)
Start Time (START_TIME)	Interval start time (GMT format)	--	time_t	No	Agent Collector	
User (USER)	Logon name of the user who issued the command	--	string(257)	No	master..sysprocesses .loginame	sys.dm_exec_sessio ns.login_name

Transaction Log Overview (PI_TLOG)

Function

The Transaction Log Overview (PI_TLOG) record indicates information related to transaction log space. One record is created for each database transaction log. This is a multi-instance record.

Default and changeable values

Item	Default value	Changeable
Collection Interval	60	Y
Collection Offset	0	Y
Log	No	Y
LOGIF	(Blank)	Y
Over 10 Sec Collection Time	No	N

ODBC key field

PI_TLOG_DB_NAME

Lifetime

From the creation until deletion of a database

Record size

- Fixed part: 681 bytes
- Variable part: 313 bytes

Fields

View name (Manager name)	Description	Summary	Format	Delta	Data source
DB Name (DB_NAME)	Database name ^{#1}	COPY	string(257)	No	DBCC SQLPERF(LOGSPACE)
Log Size Mbytes (LOG_SIZE_MB)	Size of space allocated to transaction log (in megabytes) ^{#2}	AVG	double	No	DBCC SQLPERF(LOGSPACE)
Log Space Used % (LOG_SPACE_USED_ PCT)	Percentage of transaction log space being used by transaction log ^{#2}	AVG	double	No	DBCC SQLPERF(LOGSPACE)
Max Log Space Used % (MAX_LOG_SPACE_ USED_PCT)	Maximum percentage of log space used within an interval	HI	double	No	DBCC SQLPERF(LOGSPACE)
Max Log Space Used Mbytes (MAX_LOG_SPACE_ USED_MB)	Maximum size of log space allocated within an interval (in megabytes)	HI	double	No	DBCC SQLPERF(LOGSPACE)
Record Time (RECORD_TIME)	Interval end time (GMT format) ^{#1}	COPY	time_t	No	Agent Collector

View name (Manager name)	Description	Summary	Format	Delta	Data source
Record Type (INPUT_RECORD_TYPE)	Record type (always TLOG) #1	COPY	char(8)	No	Agent Collector
Start Time (START_TIME)	Interval start time (GMT format) #1	COPY	time_t	No	Agent Collector

User-Defined Counter Overview (PI_UCTR)

Function

The User-Defined Counter Overview (PI_UCTR) record indicates information related to each user-defined counter. Only one record is created.

Default and changeable values

Item	Default value	Changeable
Collection Interval	60	Y
Collection Offset	0	Y
Log	No	Y
LOGIF	(Blank)	Y
Over 10 Sec Collection Time	No	N

ODBC key field

None

Lifetime

From the time each counter is defined until the time the definition is canceled

Record size

- Fixed part: 761 bytes
- Variable part: 0 bytes

Fields

View name (Manager name)	Description	Sum mary	Format	Delta	Data source	
					SQL Server version 2014 or earlier	SQL Server version 2016 or later
Record Time (RECORD_TIME)	Interval end time (GMT format) #1	COP Y	time_t	No	Agent Collector	
Record Type (INPUT_RECOR D_TYPE)	Record type (always UCTR)#1	COP Y	char(8)	No	Agent Collector	
SQL User Counter 1 (COUNTER_1)	Microsoft SQL Server user definition counter 1#1	COP Y	double	No	master..sysperfinfo. User counter1	sys.dm_os_perform ance_counters.User counter1
SQL User Counter 2 (COUNTER_2)	Microsoft SQL Server user definition counter 2#1	COP Y	double	No	master..sysperfinfo. User counter2	sys.dm_os_perform ance_counters.User counter2
SQL User Counter 3 (COUNTER_3)	Microsoft SQL Server user definition counter 3#1	COP Y	double	No	master..sysperfinfo. User counter3	sys.dm_os_perform ance_counters.User counter3

View name (Manager name)	Description	Summary	Format	Delta	Data source	
					SQL Server version 2014 or earlier	SQL Server version 2016 or later
SQL User Counter 4 (COUNTER_4)	Microsoft SQL Server user definition counter 4 ^{#1}	COPY	double	No	master..sysperfinfo. User counter4	sys.dm_os_performance_counters.User counter4
SQL User Counter 5 (COUNTER_5)	Microsoft SQL Server user definition counter 5 ^{#1}	COPY	double	No	master..sysperfinfo. User counter5	sys.dm_os_performance_counters.User counter5
SQL User Counter 6 (COUNTER_6)	Microsoft SQL Server user definition counter 6 ^{#1}	COPY	double	No	master..sysperfinfo. User counter6	sys.dm_os_performance_counters.User counter6
SQL User Counter 7 (COUNTER_7)	Microsoft SQL Server user definition counter 7 ^{#1}	COPY	double	No	master..sysperfinfo. User counter7	sys.dm_os_performance_counters.User counter7
SQL User Counter 8 (COUNTER_8)	Microsoft SQL Server user definition counter 8 ^{#1}	COPY	double	No	master..sysperfinfo. User counter8	sys.dm_os_performance_counters.User counter8
SQL User Counter 9 (COUNTER_9)	Microsoft SQL Server user definition counter 9 ^{#1}	COPY	double	No	master..sysperfinfo. User counter9	sys.dm_os_performance_counters.User counter9
SQL User Counter 10 (COUNTER_10)	Microsoft SQL Server user definition counter 10 ^{#1}	COPY	double	No	master..sysperfinfo. User counter10	sys.dm_os_performance_counters.User counter10
Start Time (START_TIME)	Interval start time (GMT format) ^{#1}	COPY	time_t	No	Agent Collector	

User Process Detail (PD_USER)

Function

The User Process Detail (PD_USER) record indicates information related to each logged-on user. One record is created for each user process. This is a multi-instance record.

Default and changeable values

Item	Default value	Changeable
Collection Interval	60	Y
Collection Offset	0	Y
Log	No	Y
LOGIF	(Blank)	Y
Over 10 Sec Collection Time	No	N

ODBC key field

- PD_USER_SID
- PD_USER_SPID

Lifetime

From the time a process starts until the time it stops

Record size

- Fixed part: 681 bytes
- Variable part: 791 bytes

Fields

View name (Manager name)	Description	Summary	Format	Delta	Data source	
					SQL Server version 2014 or earlier	SQL Server version 2016 or later
CPU Time (CPU_TIME)	Total time the CPU was busy for the user Correct values cannot be collected for this field.	--	utime	No	master..sysprocesses .cpu	sys.dm_exec_sessions.cpu_time, sys.dm_exec_requests.cpu_time
Locks held (LOCKS_HELD)	Number of locks held by user connection	--	ulong	No	master..syslockinfo. req_spid	sys.dm_tran_locks.request_session_id
Login Name (LOGIN_NAME)	Actual name of the user	--	string(257)	No	master..syslogins. loginname	sys.server_principals.name
Mem Pages (MEMORY)	SQL Server 2014 or earlier Amount of memory allocated to user connection (1 page equals 8 kilobytes)	--	ulong	No	master..sysprocesses .memusage	sys.dm_exec_sessions.memory_usage

View name (Manager name)	Description	Summary	Format	Delta	Data source	
					SQL Server version 2014 or earlier	SQL Server version 2016 or later
Mem Pages (MEMORY)	SQL Server 2016 or later Number of pages of memory used for user connection	--	ulong	No	master..sysprocesses .memusage	sys.dm_exec_sessions.memory_usage
Physical I/O (PHYSICAL_IO)	Total number of disk read and write operations by the user	--	double	No	master..sysprocesses .physical_io	sys.dm_exec_sessions.reads, sys.dm_exec_sessions.writes, sys.dm_exec_requests.reads, sys.dm_exec_requests.writes
Record Time (RECORD_TIME)	Interval end time (GMT format)	--	time_t	No	Agent Collector	
Record Type (INPUT_RECORD_TYPE)	Record type (always USER)	--	char(8)	No	Agent Collector	
Role (ROLE)	Fixed server role to which the user belongs. Options are delimited by commas.	--	string(80)	No	master..syslogins	sys.server_principals
SID (SID)	Security ID of the user. Hexadecimal. If information cannot be obtained from the syslogins system table of Microsoft SQL Server, it is obtained from the sysprocesses system table.	--	string(171)	No	master..syslogins.sid or master..sysprocesses.sid	sys.databases.owner_sid or sys.dm_exec_sessions.security_id
SPID (SPID)	Connection process ID of the user	--	word	No	master..sysprocesses .spid	sys.dm_exec_sessions.session_id
Start Time (START_TIME)	Interval start time (GMT format)	--	time_t	No	Agent Collector	
User (USER_ID)	User ID SQL Server 2014 or earlier If information cannot be obtained from the syslogins system table of Microsoft SQL Server, it is obtained from the sysprocesses system table. If the logon name used is 61 characters or longer, the part exceeding 61 characters is cut off. SQL Server 2016 or later If information cannot be obtained from the sys.server_principals system table of Microsoft SQL Server, it is obtained from the dm_exec_sessions system table.	--	string(257)	No	master..sysprocesses.sid, master..syslogins.name or master..sysprocesses.sid, master..sysprocesses.loginame	sys.dm_exec_requests.session_id, sys.server_principals.name or sys.dm_exec_sessions.security_id, sys.dm_exec_sessions.login_name

View name (Manager name)	Description	Summary	Format	Delta	Data source	
					SQL Server version 2014 or earlier	SQL Server version 2016 or later
User (USER_ID)	If the logon name used is 61 characters or longer, the part exceeding 61 characters is cut off.	--	string(257)	No	master..sysprocesses .sid, master..syslogins.name or master..sysprocesses .sid, master..sysprocesses .loginame	sys.dm_exec_requests.session_id, sys.server_principals.name or sys.dm_exec_sessions.security_id, sys.dm_exec_sessions.login_name

6

Messages

This chapter describes the message format used by PFM - Agent for Microsoft SQL Server, lists the locations to which messages are output, shows which messages are output to the Windows event log, and describes the messages in detail.

6.1 Message format

This section shows the format of messages that are issued by PFM - Agent for Microsoft SQL Server, and the notations used in this manual to explain the messages.

6.1.1 Format of output messages

This subsection explains the format of the messages issued by PFM - Agent for Microsoft SQL Server. Each message consists of the message ID, followed by the message text. The message format is as follows:

```
KAVFnnnnn-Y message-text
```

The message ID indicates the following:

K

System identifier.

AVF

Indicates a PFM - Agent for Microsoft SQL Server message.

nnnnn

Serial number of the message. PFM - Agent for Microsoft SQL Server message numbers are in the format 21xxx.

Y

Type of message:

- E: Error
Message issued when the system cancels processing.
- W: Warning
Message issued when the system resumes processing after message output.
- I: Information
Message in which the system provides the user with information.
- Q: Query
Message in which the system prompts the user for a response.

The following is the correspondence of the message types to the Windows event log types:

-E

- Level: Error
- Description: Error message

-W

- Level: Warning
- Description: Warning message

-I

- Level: Information
- Description: Additional information message

-Q

(Not output)

6.1.2 Format of message explanation

This section describes the format used to explain messages in this manual. The portion of message text that is shown in bold represents information that is variable depending on the situation. The manual lists the messages in the order of the message IDs. The following illustrates the format of a message explanation:

message-ID

message-text

Explanation of the message

(S)

Explains the processing performed by the system.

(O)

Explains the action the operator should take when the message is displayed.



Note

Reference note:

When contacted by an operator, see [7. Error Handling Procedures](#), collect the log information, and conduct initial checking. When you conduct initial checking to determine the cause of a problem, examine all applicable log information, such as the log information for the OS (Windows event log) and the log information output by PFM - Agent for Microsoft SQL Server. This log information enable you to understand the details of the problem, take appropriate action, and prevent the problem from occurring in the future. You should also make a record of the operations that led to the problem and determine whether or not the problem is likely to recur.

6.2 Message output destinations

This section shows the output destinations of the messages issued by PFM - Agent for Microsoft SQL Server.

In the following table, Y and N have the following meanings:

Legend:

Y: Message is output.

N: Message is not output.

Table 6–1: Output destinations of PFM - Agent for Microsoft SQL Server messages

Message ID	Output destination					
	Windows event log	Common message log	Agent log		JP1 system event#1	Agent event#2
			Normal log	Error log		
KAVF21001	Y	Y	N	N	N	N
KAVF21002	Y	Y	N	N	N	N
KAVF21003	Y	Y	N	N	N	N
KAVF21004	Y	Y	N	N	N	N
KAVF21200	N	Y	N	N	N	N
KAVF21400	N	Y	N	N	N	N
KAVF21401	N	Y	N	N	Y	N
KAVF21402	N	Y	N	N	N	N
KAVF21403	N	Y	N	N	N	N
KAVF21404	N	Y	N	N	N	N
KAVF21405	N	Y	N	N	N	N
KAVF21406	N	Y	N	N	N	N
KAVF21407	N	Y	N	N	N	N
KAVF21408	N	Y	N	N	N	N
KAVF21409	N	Y	N	N	N	N
KAVF21410	N	Y	N	N	N	N
KAVF21411	N	Y	N	N	N	N
KAVF21600	N	Y	N	N	N	N
KAVF21601	Y	Y	N	N	N	N
KAVF21602	Y	Y	N	N	N	N
KAVF21603	Y	Y	N	N	N	N
KAVF21604	Y	Y	N	N	N	N
KAVF21605	Y	Y	N	N	N	N
KAVF21606	Y	Y	N	N	N	N
KAVF21607	Y	Y	N	N	N	N

Message ID	Output destination					
	Windows event log	Common message log	Agent log		JP1 system event#1	Agent event#2
			Normal log	Error log		
KAVF21608	N	Y	N	N	N	N
KAVF21609	Y	Y	N	N	N	N
KAVF21610	Y	Y	N	N	N	N
KAVF21611	Y	Y	N	N	N	N
KAVF21612	Y	Y	N	N	N	N
KAVF21613	Y	Y	N	N	N	N
KAVF21614	N	Y	N	N	N	N
KAVF21700	N	Y	N	N	N	N
KAVF21800	N	N	Y	N	N	N
KAVF21801	N	N	Y	N	N	N
KAVF21802	N	N	Y	N	N	N
KAVF21803	N	N	Y	N	N	N
KAVF21804	N	N	Y	N	N	N
KAVF21805	N	N	Y	N	N	N
KAVF21806	N	N	Y	N	N	N
KAVF21807	N	N	Y	N	N	N
KAVF21808	N	N	Y	N	N	N
KAVF21809	N	N	Y	N	N	N
KAVF21810	N	N	N	Y	N	N
KAVF21811	N	N	N	Y	N	N
KAVF21812	N	N	N	Y	N	N
KAVF21813	N	N	N	Y	N	N
KAVF21814	N	N	N	Y	N	N
KAVF21815	N	N	N	Y	N	N
KAVF21816	N	N	N	Y	N	N
KAVF21817	N	N	N	Y	N	N
KAVF21818	N	N	Y	N	N	N
KAVF21819	N	N	Y	N	N	N
KAVF21820	N	N	N	Y	N	N
KAVF21821	N	N	N	Y	N	N
KAVF21822	N	N	N	Y	N	N
KAVF21823	N	N	Y	N	N	N
KAVF21824	N	N	N	Y	N	N

Message ID	Output destination					
	Windows event log	Common message log	Agent log		JP1 system event#1	Agent event#2
			Normal log	Error log		
KAVF21825	N	N	Y	N	N	N
KAVF21826	N	N	N	Y	N	N
KAVF21827	N	N	Y	N	N	N
KAVF21828	N	N	N	Y	N	N
KAVF21829	N	N	N	Y	N	N
KAVF21830	N	N	N	Y	N	N
KAVF21831	N	N	N	Y	N	N
KAVF21832	N	N	N	Y	N	N
KAVF21833	N	N	N	Y	N	N
KAVF21834	N	N	N	Y	N	N
KAVF21835	N	N	N	Y	N	N
KAVF21836	N	N	N	Y	N	N
KAVF21837	N	N	N	Y	N	N
KAVF21838	N	N	N	Y	N	N
KAVF21839	N	N	N	Y	N	N
KAVF21840	N	N	N	Y	N	N
KAVF21841	N	N	N	Y	N	N
KAVF21842	N	N	N	Y	N	N
KAVF21843	N	N	N	Y	N	N
KAVF21844	N	N	N	Y	N	N
KAVF21845	N	Y	N	N	N	N
KAVF21846	N	N	N	Y	N	N
KAVF21847	N	N	Y	N	N	N
KAVF21848	N	N	N	Y	N	N
KAVF21849	N	N	N	Y	N	N
KAVF21850	N	N	N	Y	N	N
KAVF21851	N	N	Y	N	N	N

#1

P1 system events are the events to notify JP1/IM of status change of the agent. For details about JP1 system events, see the chapter on how to coordinate Performance Management programs and JP1/IM programs and conduct operation monitoring in the *JP1/Performance Management User's Guide*.

Table 6–2: Prerequisite programs to issue JP1 system events

Hosts	Prerequisite program	Version
PFM - Manager host	PFM - Manager	09-00 or later

Hosts	Prerequisite program	Version
PFM - Web Console host	PFM - Web Console	08-00 or later
PFM - Agent host	PFM - Agent for Microsoft SQL Server	08-00 or later (To issue an event output by PFM - Agent, the version must be 09-00 or later.)
	PFM - Manager or PFM - Base	09-00 or later
	JP1/Base	08-50 or later

#2

Agent events are the events to notify PFM - Manager of status change of the agent. For details about agent events, see the chapter on displaying the events in the *JP1/Performance Management User's Guide*.

Table 6-3 shows the prerequisite programs to issue agent events

Table 6–3: Prerequisite programs to issue agent events

Hosts	Prerequisite programs	Version
PFM - Manager host	PFM - Manager	09-00 or later
PFM - Web Console host	PFM - Web Console	08-00 or later
PFM - Agent host	PFM - Manager or PFM - Base	09-00 or later

6.3 Messages output to the Windows event log

This section lists the messages that PFM - Agent for Microsoft SQL Server outputs to the Windows event log.

The Windows event log is displayed as the application log in the Event Viewer window.

Note

Reference note:

To open the Event Viewer window, from the Windows **Start** menu, select **Administrative Tools** and then **Event Viewer**.

An event issued by PFM - Agent for Microsoft SQL Server is indicated in the **Source** column of the Event Viewer window by the identifier PFM-SQL.

Table 6-4 lists the messages that PFM - Agent for Microsoft SQL Server outputs to the Windows event log.

Table 6–4: Messages output to the Windows event log

Message ID	Windows event log	
	Event ID	Type
KAVF21001	21001	Information
KAVF21002	21002	Error
KAVF21003	21003	Information
KAVF21004	21004	Error
KAVF21601	21601	Error
KAVF21602	21602	Error
KAVF21603	21603	Error
KAVF21604	21604	Error
KAVF21605	21605	Error
KAVF21606	21606	Error
KAVF21607	21607	Error
KAVF21609	21609	Error
KAVF21610	21610	Error
KAVF21611	21611	Error
KAVF21612	21612	Error
KAVF21613	21613	Error

6.4 Messages

This section explains the messages issued by PFM - Agent for Microsoft SQL Server, and the corresponding actions to be taken. The individual messages issued by PFM - Agent for Microsoft SQL Server are explained as follows.

KAVF21001-I

Agent Collector has stopped. (host=*host-name*, service=*service-ID*)

Agent Collector service stopped normally.

(S)

Stops Agent Collector service processing.

KAVF21002-E

Agent Collector has failed to start.

Agent Collector service startup failed.

(S)

Stops Agent Collector service processing.

(O)

Check the immediately preceding message that was issued to the common message log and take appropriate action.

KAVF21003-I

Agent Collector has started. (host=*host-name*, service=*service-ID*)

Agent Collector service startup was completed.

(S)

Starts Agent Collector service performance data collection processing.

KAVF21004-E

Agent Collector has stopped abnormally.

Agent Collector service stopped abnormally.

(S)

Stops Agent Collector service processing.

(O)

Check the immediately preceding message that was output to the event log and common message log and take appropriate action.

KAVF21200-I

The connection to the SQL Server has been recovered.

Connection to Microsoft SQL Server was recovered during record collection processing.

(S)

Continues Agent Collector service record collection processing.

KAVF21400-W

An attempt to connect to the SQL Server has failed.

A connection to the monitoring target Microsoft SQL Server could not be established.

(S)

Continues Agent Collector service processing.

(O)

Ensure that the Microsoft SQL Server has been started. Also ensure that the following items entered during the creation of the monitoring target were correct:

- *Microsoft SQL Server instance name*
- `SQL_HOST` (*monitored host-name*)
- `SQL_USER` (*user-name*)
- `SQL_PASSWORD` (*password*)

If the Instance-name of Microsoft SQL Server is incorrect, cancel setup of the instance environment, and then set up the instance environment again with a correct instance name. If other items are incorrectly specified, update the instance environment with correct values.

KAVF21401-W

Data collection for record-name has failed.

The data necessary for creating the record indicated by *record-name* could not be collected.

(S)

Continues Agent Collector service processing.

(O)

If this message is continuously output, ensure that the system environment settings for the monitoring target system are correct. If you cannot determine the cause of the problem, collect maintenance information and contact the system administrator. For details about how to collect maintenance information, see the chapter that describes troubleshooting in the *JPI/Performance Management User's Guide*.

KAVF21402-W

Agent Collector has failed in opening the SQL Server log file. (path=*log-file-path*)

An attempt to open the Microsoft SQL Server error log file failed.

(S)

Continues Agent Collector service processing.

(O)

Ensure that the following item entered during the creation of the instance environment was correct:

- `SQL_ERRORLOG` (*error log file name*)

If this item is incorrectly specified, update the instance environment with a correct setting.

KAVF21403-W

Agent Collector has failed to open registry key *registry-name*, with error code *maintenance-code*.

An attempt to open the registry indicated by *registry-name* failed. *maintenance-code* is a Win32 system error code.

(S)

Continues Agent Collector service processing.

(O)

Ensure that the OS resource is sufficient and that no error has occurred in the OS itself.

KAVF21404-W

Agent Collector has failed to get the value of registry key *registry-name*, with error code *maintenance-code*.

An attempt to load the registry indicated by *registry-name* failed. *maintenance-code* is a Win32 system error code.

(S)

Continues Agent Collector service processing.

(O)

Ensure that Microsoft SQL Server has been installed correctly and that no error has occurred in the OS itself.

KAVF21405-W

No entry for *setting-item* in the service startup initialization file. The default value is *default-value*.

The value indicated by *setting-item* could not be obtained from the service startup initialization file.

(S)

Uses the default value for the setting item.

(O)

On the **Agents** page of PFM - Web Console, make sure that the items under **Agent Configuration** are set correctly as agent properties.

KAVF21406-W

The specified file *file-name* is not an error log file of SQL Server.

Because the specified error log file is not an error log file of Microsoft SQL Server, data on the Microsoft SQL Server error log could not be collected.

(S)

Data for the Microsoft SQL Server error logs is not collected, and processing for the Agent Collector service continues.

(O)

On the Agents page of PFM - Web Console, make sure that the value of Errorlog under Agent Configuration are set correctly as agent properties. If it is incorrect, update the instance by specifying the correct information.

KAVF21407-W

The version of the specified error log file *file-name* of SQL Server is not supported.

Because the specified error log file is an error log file of Microsoft SQL Server not supported by PFM - Agent for Microsoft SQL Server, data on the Microsoft SQL Server error log could not be collected.

(S)

Data for the Microsoft SQL Server error logs is not collected, and processing for the Agent Collector service continues.

(O)

Ensure that the monitoring target Microsoft SQL Server is a version supported by PFM - Agent for Microsoft SQL Server.

KAVF21408-W

Agent Collector could not collect the record for the SQL Server Log due to the wrong format of jpcagt.ini file.

The record for the Microsoft SQL Server error log could not be collected because the `jpcagt.ini` file was invalid.

(S)

Data for the Microsoft SQL Server error logs is not collected, and processing for the Agent Collector service continues.

(O)

First, check the following and take the appropriate action:

- Is access permission to the `jpcagt.ini` file granted?
If not, assign access permission to the `jpcagt.ini` file.
- Is the `jpcagt.ini` file write-enabled?
If not, write-enable the `jpcagt.ini` file.

If neither of the above is applicable, the `jpcagt.ini` file is damaged. To repair the file:

1. Stop the service of the PFM - Agent for Microsoft SQL Server instance environment.

2. Copy the `jpcagt.ini.model` file to the `jpcagt.ini` file.

Copy source: `installation-folder\agtq\agent\instance-name\jpcagt.ini.model`

Copy destination: `installation-folder\agtq\agent\instance-name\jpcagt.ini`

3. Start the service of PFM - Agent for Microsoft SQL Server.

4. Set up record collection.

On the **Agents** page of PFM - Web Console, make sure that the items under **Agent Configuration** are set correctly as agent properties.

KAVF21409-W

Agent property *setting-item* has been set to the minimum value *minimum-value* since the specified value exceeded the lower limit of the property.

Because a value smaller than the range of specifiable values was specified as an Agent Collector property, the allowed minimum value was set.

(S)

Ignores the specified value, sets the minimum value, and continues processing.

(O)

Check whether the specified value is acceptable. If it is not, re-specify an appropriate value.

KAVF21410-W

Agent property *setting-item* has been set to the maximum value *maximum-value* since the specified value exceeded the upper limit of the property.

Because a value greater than the range of specifiable values was specified as an Agent property, the allowed maximum value was set.

(S)

Ignores the specified value, sets the maximum value, and continues processing.

(O)

Check whether the specified value is acceptable. If it is not, re-specify an appropriate value.

KAVF21411-W

A non-numeral character is specified to the Agent property field.

Because a non-numerical value was specified in the Agent property field that requires a numerical value, the item value could not be updated.

(S)

Ignores the specified value and continues processing using the existing value.

(O)

Make sure that only a numerical value is specified.

KAVF21600-E

Initialization of the trace log is failed due to: *cause*

An attempt to initialize log output processing failed.

(S)

Stops Agent Collector service processing.

(O)

Ensure that no error has occurred in the OS itself.

KAVF21601-E

Initialization of Agent Collector has failed.

The service startup initialization file could not be loaded during Agent Collector service startup processing.

(S)

Stops Agent Collector service processing.

(O)

Ensure that the service startup initialization file (*jpcagt.ini*) is located under *installation-folder\agtq\agent\instance-name*

KAVF21602-E

No entry for the SQL Server instance name in the service startup initialization file.

The instance name of the monitoring target Microsoft SQL Server could not be obtained from the service startup initialization file during Agent Collector service startup processing.

(S)

Stops Agent Collector service processing.

(O)

Check whether the following item specified during setup of the instance is correct:

- Microsoft SQL Server instance name

If this item is incorrectly specified, cancel setup of the instance environment, and then set up the instance environment again with a correct instance name.

KAVF21603-E

No login ID for instance *instance-name* in the service startup initialization file.

The account name (user name) of the monitoring target Microsoft SQL Server could not be obtained from the service startup initialization file during Agent Collector service startup processing.

(S)

Stops Agent Collector service processing.

(O)

Check whether the following item specified during setup of the instance is correct:

- SQL_USER (*user-name*)

If it is incorrect, update the instance by specifying the correct information.

KAVF21604-E

No password entry for instance *instance-name* in the service startup initialization file.

The account name (password) of the monitoring target Microsoft SQL Server could not be obtained from the service startup initialization file during Agent Collector service startup processing.

(S)

Stops Agent Collector service processing.

(O)

Check whether the following item specified during setup of the instance is correct:

- SQL_PASSWORD (*password*)

If it is incorrect, update the instance by specifying the correct information.

KAVF21605-E

No log file path to the SQL Server for instance *instance-name* in the service startup initialization file.

The account name (log file path) of the monitoring target Microsoft SQL Server could not be obtained from the service startup initialization file during Agent Collector service startup processing.

(S)

Stops Agent Collector service processing.

(O)

Check whether the following item specified during setup of the instance is correct:

- `SQL_ERRORLOG` (*error log file path*)

If it is incorrect, update the instance by specifying the correct information.

KAVF21606-E

An error occurred during initialization of the SQL Server API.

An attempt to initialize the database access API failed.

(S)

Stops Agent Collector service processing.

(O)

Ensure that no error has occurred in the OS itself.

KAVF21607-E

Initialization of TCP/IP has failed, with error code *maintenance-code*.

Initialization of TCP/IP failed during Agent Collector service startup processing.

(S)

Stops Agent Collector service processing.

(O)

Ensure that the network settings are correct.

KAVF21608-E

The execution of the SQL query has failed, with error code *maintenance-code*.

Execution of SQL query failed during data collection.

(S)

Continues Agent Collector service processing.

(O)

If this message is continuously output, ensure that the system environment settings for the monitoring target system are correct. If you cannot determine the cause of the problem, collect maintenance information and contact the system administrator.

For details about how to collect maintenance information, see the chapter that describes troubleshooting in the *JPI/Performance Management User's Guide*.

KAVF21609-E

No host name for instance *instance-name* in the service startup initialization file.

The host name of the monitoring target Microsoft SQL Server could not be obtained from the target information file during Agent Collector service startup processing.

(S)

Stops Agent Collector service processing.

(O)

Check whether the following item specified during setup of the instance is correct:

- `SQL_HOST` (*monitored host-name*)

If it is incorrect, update the instance by specifying the correct information.

KAVF21610-E

Agent Collector could not connect to the SQL Server due to the SQL Server Authentication failure.

Connection to the Microsoft SQL Server could not be established using the SQL Server authentication mode.

(S)

Stops Agent Collector service processing.

(O)

Check whether the following item specified during setup of the instance is correct:

- `SQL_HOST` (*monitored host-name*)
- `SQL_USER` (*user-name*)
- `SQL_PASSWORD` (*password*)

If it is incorrect, update the instance by specifying the correct information.

KAVF21611-E

Agent Collector could not connect to the SQL Server due to the Windows Authentication failure.

Connection to the Microsoft SQL Server could not be established using the Windows authentication mode.

(S)

Stops Agent Collector service processing.

(O)

Check whether the following item specified during setup of the instance is correct:

- `SQL_HOST` (*monitored host-name*)
- `SQL_USER` (*user-name*)

If it is incorrect, update the instance by specifying the correct information.

KAVF21612-E

While executing *function-name* function *called-function-name* failed.

An error occurred during the execution of the function indicated by *function-name*.

(S)

Stops Agent Collector service processing.

(O)

Collect maintenance information and contact the system administrator. For details about how to collect maintenance information, see the chapter that describes troubleshooting in the *JPI/Performance Management User's Guide*.

KAVF21613-E

"*exception-name*" exception raised. (details = "*detailed-information*")

The *exception-name* exception occurred.

(S)

Stops Agent Collector service processing.

(O)

Collect maintenance information and contact the system administrator. For details about how to collect maintenance information, see the chapter that describes troubleshooting in the *JPI/Performance Management User's Guide*.

KAVF21614-E

Failed to output to Agent log. "*OS-function*" failed. Error code = "*error-code*"

An attempt to output information to the agent log has failed. The OS function indicated by *OS-function* failed due to the error indicated by *error-code*.

(S)

Continues Agent Collector service processing. The system stops collecting agent log information until the error has been corrected.

(O)

Check the destination path, access permissions, and other information related to the agent log.

KAVF21700-E

Memory allocation for object *object-name* has failed.

An attempt to allocate memory for the object indicated by *object-name* failed.

(S)

Stops Agent Collector service processing.

(O)

Increase the available memory.

KAVF21800-I

Server: "*computer-name*", User: "*user-name*", Errorlog: "SQL Server error log file path"

The system will log information that the Agent Collector service sends to Microsoft SQL Server.

(S)

Starts Agent Collector service processing.

KAVF21801-I

Agent Collector started : "*status*"

The Agent Collector service is being started. One of the following character strings is set in *status*:

- Now starting

- TCP/IP Initialization Successful
- Initializing

(S)

Starts the Agent Collector service.

KAVF21802-I

Agent Collector ended.

The Agent Collector service is being terminated.

(S)

Terminates the Agent Collector service.

KAVF21803-I

Records collection started.

Record collection started.

(S)

Starts record collection processing by the Agent Collector service.

KAVF21804-I

Connection to SQL Server started. Authentication : "*authentication-method*"

Connection to Microsoft SQL Server will start.

(S)

Starts processing to connect to Microsoft SQL Server.

KAVF21805-I

Connection to SQL Server ended normally.

Connection to Microsoft SQL Server has been completed.

(S)

Completes connection to Microsoft SQL Server, and continues processing.

KAVF21806-I

The process of the record started = "*record-name*"

Processing of the record indicated by *record-name* will start.

(S)

Starts processing of the indicated record by the Agent Collector service.

KAVF21807-I

Getting record ended = "*record-name*" -> Storing started [count = "*number-of-records*"]

Collection of data for the record indicated by *record-name* terminated.

(S)

Terminates collection of data for the indicated record, and starts saving the data in the Stored database.

KAVF21808-I

The Process of the record ended = "*record-name*"

Processing of the record indicated by *record-name* will terminate.

(S)

Terminates processing of the indicated record by the Agent Collector service.

KAVF21809-I

Records collection ended.

Record collection terminated.

(S)

Terminates record collection processing by the Agent Collector service.

KAVF21810-E

An attempt to connect to SQL Server failed. ("*Microsoft-SQL-Server-detailed-error-information*")

An error occurred during an attempt to connect to Microsoft SQL Server. The Microsoft SQL Server detailed error information is an error code returned by Microsoft SQL Server. If Microsoft SQL Server also returns a message for the error code, the message is also displayed.

(S)

Continues Agent Collector service processing.

(O)

Check the following items:

- Microsoft SQL Server has been started.
- The following items entered during setup of the instance are correct.
 - Microsoft SQL Server instance name
 - SQL_HOST (*monitored host-name*)
 - SQL_USER (*user-name*)
 - SQL_PASSWORD (*password*)

If this item is incorrectly specified, cancel setup of the instance environment, and then set up the instance environment again with a correct instance name.

If the items entered during setup of the instance are incorrect, update the instance by specifying the correct information.

- If an *alias* is specified on the PFM - Agent host by using SQL Server Client Network Utility or any other tool, make sure that the following settings are made:
 - The *alias* settings are correct.
 - A 64-bit *alias* is specified.

For details about *alias* setting, see [3.3.2\(5\) Notes when a non-default Microsoft SQL Server port number or the named pipe protocol is used to connect with Microsoft SQL Server](#).

If the *alias* settings and all items specified during setup of Microsoft SQL Server are correct, correct the error indicated by the error code. For details about Microsoft SQL Server error codes, see your Microsoft SQL Server documentation.

KAVF21811-E

An error occurred in OS function "*Win32-API-function-name*". (rc = "*maintenance-code*")

An error occurred in the function indicated by *Win32-API-function-name*. *maintenance-code* is a Win32 system error code.

(S)

Stops Agent Collector service processing.

(O)

Ensure that the OS resource is sufficient and that no error has occurred in the OS itself. If this message is continuously output, ensure that the system environment settings for the monitoring target system are correct. If you cannot determine the cause of the problem, collect maintenance information and contact the system administrator.

For details about how to collect maintenance information, see the chapter that describes troubleshooting in the *JPI/Performance Management User's Guide*.

KAVF21812-E

SQL Server(connection driver)returned an error.

(rc = "*Microsoft-SQL-Server-error-code*", msg = "*Microsoft-SQL-Server-error-message*")

An error was returned when an attempt was made to access Microsoft SQL Server.

(S)

Continues Agent Collector service processing.

(O)

Make sure that Microsoft SQL Server is started, and correct the error indicated by *Microsoft-SQL-Server-error-code*. If Microsoft SQL Server has also returned an error message for the error mode, the error message is also output.

For details about Microsoft SQL Server error codes, see your Microsoft SQL Server documentation.

KAVF21813-E

SQL Server(ADO)returned an error. (rc = "*Microsoft-SQL-Server-error-code*", method = "*ADO-method-name*", msg = "*Microsoft-SQL-Server-error-message*")

An error was returned when an attempt was made to access Microsoft SQL Server via ADO (Microsoft ActiveX data object).

(S)

Continues Agent Collector service processing.

(O)

Make sure that Microsoft SQL Server is started, and correct the error indicated by *Microsoft-SQL-Server-error-code*. If Microsoft SQL Server has also returned an error message for the error mode, the error message is also output.

For details about Microsoft SQL Server error codes, see your Microsoft SQL Server documentation.

KAVF21814-E

An attempt to open an SQL Server log file failed. (rc = *maintenance-code*, path = *log-file-path*)

An attempt to open the Microsoft SQL Server error log file failed.

(S)

Continues Agent Collector service processing. *maintenance-code* indicates the Win32 system error code.

(O)

Make sure that the following item entered during the creation of the instance environment is correct:

- `SQL_ERRORLOG` (*error log file name*)

If this item is incorrectly specified, update the instance environment

KAVF21815-E

An error occurred: "*error-details*"

An error occurred during Agent Collector service processing.

(S)

Stops Agent Collector service processing.

(O)

Ensure that the OS resource is sufficient and that no error has occurred in the OS itself. If this message is continuously output, ensure that the system environment settings for the monitoring target system are correct. If you cannot determine the cause of the problem, collect maintenance information and contact the system administrator.

For details about how to collect maintenance information, see the chapter that describes troubleshooting in the *JPI/Performance Management User's Guide*.

KAVF21816-E

An exception occurred: "*exception-error-details*"

An exception error occurred during Agent Collector service processing.

(S)

Continues Agent Collector service processing.

(O)

Ensure that the OS resource is sufficient and that no error has occurred in the OS itself. If this message is continuously output, ensure that the system environment settings for the monitoring target system are correct. If you cannot determine the cause of the problem, collect maintenance information and contact the system administrator.

For details about how to collect maintenance information, see the chapter that describes troubleshooting in the *JP1/Performance Management User's Guide*.

KAVF21817-W

A warning-level error occurred: "*warning-error-details*"

A warning error occurred during Agent Collector service processing.

(S)

Continues Agent Collector service processing.

(O)

Check the following items:

- OS resources are sufficient.
- No errors have occurred anywhere in the OS.
- The system environment settings of the monitoring target are correct.

KAVF21818-I

Process "*process-name*" started.

The Agent Collector service started the process indicated by *process-name*.

(S)

The Agent Collector service started the process indicated by *process-name*.

KAVF21819-I

Process "*process-name*" ended.

The Agent Collector service terminated the process indicated by *process-name*.

(S)

The Agent Collector service terminated the process indicated by *process-name*.

KAVF21820-E

Process "*process-name*" failed.

The Agent Collector service detected an error in the process indicated by *process-name*.

(S)

Continues Agent Collector service processing.

KAVF21821-W

The value of the agent property "*property-name*" is either invalid or outside the allowable range. (Allowable range: "*range-value*")

An invalid value or a value outside the allowable range is specified for the Agent Collector service property indicated by *property-name*.

(S)

Ignores the specified value and continues processing. The value is not changed.

(O)

Check whether the specified value is the cause of the problem. If it is, change the value to an appropriate one.

KAVF21822-W

Connection to SQL Server will be retried.

Because an attempt to connect to Microsoft SQL Server failed, connection to Microsoft SQL Server will be retried.

(S)

Retries connection to Microsoft SQL Server.

KAVF21823-I

Agent Collector has stopped. (host=*host-name*, service= *host-name*<SQL>)

Agent Collector service stopped normally.

(S)

Stops Agent Collector service processing.

KAVF21824-E

Agent Collector has failed to start.

Agent Collector service startup failed.

(S)

Stops Agent Collector service processing.

(O)

Check the immediately preceding message that was issued to the common message log and take appropriate action.

KAVF21825-I

Agent Collector has started. (host=*host-name*, service= *host-name*<SQL>)

Agent Collector service startup was completed.

(S)

Starts Agent Collector service performance data collection processing.

KAVF21826-E

Agent Collector has stopped abnormally.

Agent Collector service stopped abnormally.

(S)

Agent Monitor Collector service processing.

(O)

Check the immediately preceding message that was output to the event log and common

KAVF21827-I

The connection to the SQL Server has been recovered.

Connection to Microsoft SQL Server was recovered during record collection processing.

(S)

Continues Agent Collector service record collection processing.

KAVF21828-W

Agent Collector has failed in opening the SQL Server log file. (path=*log-file-path*)

An attempt to open the Microsoft SQL Server error log file failed.

(S)

Continues Agent Collector service processing.

(O)

Make sure that the following item entered during the creation of the instance environment is correct:

- `SQL_ERRORLOG` (*error log file name*)

If this item is incorrectly specified, update the instance environment with a correct setting.

KAVF21829-W

Agent Collector has failed to open registry key *registry-name*, with error code *maintenance-code*.

An attempt to open the registry indicated by *registry-name* failed. *maintenance-code* is a Win32 system error code.

(S)

Continues Agent Collector service processing.

(O)

Ensure that the OS resource is sufficient and that no error has occurred in the OS itself.

KAVF21830-W

Agent Monitor Collector has failed to get the value of registry key *registry-name*, with error code *maintenance-code*.

An attempt to load the registry indicated by *registry-name* failed. *maintenance-code* is a Win32 system error code.

(S)

Continues Agent Collector service processing.

(O)

Ensure that Microsoft SQL Server has been installed correctly and that no error has occurred in the OS itself.

KAVF21831-W

No entry for *setting-item* in the service startup initialization file. The default value is *default-value*.

The value indicated by *setting-item* could not be obtained from the service startup initialization file.

(S)

Uses the default value for the setting item.

(O)

On the **Agents** page of PFM - Web Console, make sure that the items under **Agent Configuration** are set correctly as agent properties.

KAVF21832-W

The specified file *file-name* is not an error log file of SQL Server.

Because the specified error log file is not an error log file of Microsoft SQL Server, data on the Microsoft SQL Server error log could not be collected.

(S)

Data for the Microsoft SQL Server error logs is not collected, and processing for the Agent Collector service continues.

(O)

On the Agents page of PFM - Web Console, make sure that the value of Errorlog under Agent Configuration are set correctly as agent properties. If it is incorrect, update the instance by specifying the correct information.

KAVF21833-W

The version of the specified error log file *file* of SQL Server is not supported.

Because the specified error log file belongs to a version of Microsoft SQL Server not supported by PFM - Agent for Microsoft SQL Server, data in the Microsoft SQL Server error log could not be collected.

(S)

Does not collect data in the Microsoft SQL Server error log, and continues the processing of the Agent Collector service.

(O)

Make sure that the version of the monitoring target Microsoft SQL Server is supported by PFM - Agent for Microsoft SQL Server.

KAVF21834-E

Initialization of the trace log is failed due to: *cause*

An attempt to initialize log output processing failed.

(S)

Stops Agent Collector service processing.

(O)

Ensure that no error has occurred in the OS itself.

KAVF21835-E

No login ID for instance *instance-name* in the target information file.

The account name (user name) of the monitoring target Microsoft SQL Server could not be obtained from the target information file during Agent Collector service startup processing.

(S)

Stops Agent Collector service processing.

(O)

Check whether the following item specified during setup of the instance is correct:

- `SQL_USER` (*user-name*)

If it is incorrect, update the instance by specifying the correct information.

KAVF21836-E

No password entry for instance *instance-name* in the service startup initialization file.

The password for the monitoring target Microsoft SQL Server could not be obtained from the target information file during Agent Collector service startup processing.

(S)

Stops Agent Collector service processing.

(O)

Check whether the following item specified during setup of the instance is correct:

- `SQL_PASSWORD` (*password*)

If it is incorrect, update the instance by specifying the correct information.

KAVF21837-E

No log file path to the SQL Server for instance *instancename* in the service startup initialization file.

An attempt to obtain the log file path of the monitored Microsoft SQL Server instance from the service startup initialization file failed during startup processing for Agent Collector.

(S)

Stops Agent Collector service processing.

(O)

Check whether the following item specified during setup of the instance is correct:

- `SQL_ERRORLOG` (*error log file name*)

If it is incorrect, update the instance by specifying the correct information.

KAVF21838-E

Initialization of TCP/IP has failed, with error code *maintenance-code*.

Initialization of TCP/IP failed during Agent Collector service startup processing.

(S)

Stops Agent Collector service processing.

(O)

Ensure that the network settings are correct.

KAVF21839-E

The execution of the SQL query has failed, with error code *maintenance-code*.

Execution of SQL query failed during data collection.

(S)

Continues Agent Collector service processing.

(O)

If this message is continuously output, ensure that the system environment settings for the monitoring target system are correct. If you cannot determine the cause of the problem, collect maintenance information and contact the system administrator.

For details about how to collect maintenance information, see the chapter that describes troubleshooting in the *JPI/Performance Management User's Guide*.

KAVF21840-E

No host name for instance *instance-name* in the target information file.

The host name of the monitoring target Microsoft SQL Server could not be obtained from the target information file during Agent Collector service startup processing.

(S)

Stops Agent Collector service processing.

(O)

Check whether the following item specified during setup of the instance is correct:

- SQL_HOST (*monitored host-name*)

If it is incorrect, update the instance by specifying the correct information.

KAVF21841-E

While executing *function-name* function *called-function-name* failed.

An error occurred during the execution of the function indicated by *function-name*.

(S)

Stops Agent Collector service processing.

(O)

Collect maintenance information and contact the system administrator. For details about how to collect maintenance information, see the chapter that describes troubleshooting in the *JPI/Performance Management User's Guide*.

KAVF21842-E

"*exception-name*" exception raised. (details = "*detailed-information*")

An *exception-name* exception occurred.

(S)

Stops Agent Collector service processing.

(O)

Collect maintenance information and contact the system administrator. For details about how to collect maintenance information, see the chapter that describes troubleshooting in the *JPI/Performance Management User's Guide*.

KAVF21843-E

Memory allocation for object *object-name* has failed.

An attempt to allocate memory for the object indicated by *object-name* failed.

(S)

Stops Agent Collector service processing.

(O)

Increase the available memory.

KAVF21844-E

The version of target SQL Server is not supported. (Ver= "*version-of-target-SQL-Server*")

The specified Microsoft SQL Server version is not supported.

(S)

Stops Agent Collector service processing.

(O)

Make sure that PFM - Agent for Microsoft SQL Server supports the version of the monitored Microsoft SQL Server.

KAVF21845-I

Agent log. path = "*agent-log-output-folder-path*"

The path to the agent log output folder for the Agent Collector service is recorded.

(S)

Continues Agent Collector service processing.

KAVF21846-W

Getting record error ("*record-name*"). This record is only in drilldown reports.

The record indicated by *record-name* could not be acquired. This record is available only in drilldown reports.

(S)

Continues Agent Collector service processing.

(O)

Set a drilldown report that is associated with the record that has the specific ODBC key for the record indicated by *record-name*. For details about drilldown reports, see the chapter on creating reports used for operation analysis in the *JPI/Performance Management User's Guide*.

KAVF21847-I

Because the fact that free space size rate(percent) of the database is smaller than 0 percent is inspected, size rate was revised. before = ("*percentage-of-free-space-before-setup*"); after = ("*percentage-of-free-space-after-setup*"); dbname= ("*database-name*").

Because the percentage of free space in the database is less than 0, the value for free space percentage is set to the value of DB_FREE_PERC_NUMBER that was specified when the `jpccconf inst setup` command was executed.

(S)

Continues processing the Agent Collector service.

KAVF21848-W

The specified number of maximum collection records was exceeded.
(record="*record-name*", maximum number="*maximumnumber-of-records-that-canbe-collected*")

The specified maximum number of records that can be collected was exceeded.

(S)

Collects data until the maximum number, and then continues processing the Agent Collector service.

KAVF21849-W

An attempt to connect to SQL Server failed, when PD_IA record is collected. ("*Microsoft-SQL-Server-detailed-error-information*")

An attempt to connect to the SQL Server failed when the PD_IA record was collected. ("*Microsoft-SQL-Server-error-details*")

(S)

Continues Agent Collector service processing.

(O)

If the monitored host is a Microsoft SQL Server, check the startup status of the monitored host.

KAVF21850-W

The specified number of maximum collection records was exceeded.
(record="*record-name*", collection number="*number-of-records-that-collected*", target number="*target-number-of-records*")

The specified maximum number of records that can be collected was exceeded.

(S)

Collects data for the number of records that can be collected, and then continues processing the Agent Collector service.

(O)

Use the monitored Microsoft SQL Server to handle the error.

KAVF21851-I

Because the fact that data unallocate space size rate(percent) of the database is smaller than 0 percent is inspected, size rate was revised. before = ("*percentage-of-free-data-space-before-revision*") : after = ("*percentage-of-free-data-space-after-revision*") : dbname = ("*database-name*").

Because the data unallocate space size rate (percentage) of the database was smaller than 0 percent, the size rate was set to the value specified for DB_FREE_PERC_NUMBER when the jpcconf target setup command was executed.

(S)

Continues processing the Agent Collector service.

7

Error Handling Procedures

This chapter describes how to troubleshoot problems in Performance Management operation, focusing mainly on problems that occur in PFM - Agent for Microsoft SQL Server. For details about how to deal with issues affecting the Performance Management system as a whole, see the chapter on troubleshooting in the *JP1/Performance Management User's Guide*.

7.1 When an error occurs

If an error occurs in Performance Management, follow the steps below.

Check events

Check the following:

- What events occur when the problem is encountered
- The content of messages (if output)
- Log information such as the common message log

For details about the causes of messages and the action to take, see [6. Messages](#). For details about the logs that are output by Performance Management, see [7.3 Log information](#).

Collect data

You need to collect data to determine the cause of the problem. See [7.4 Required troubleshooting information](#) and [7.5 Collecting troubleshooting information](#) to collect the necessary information.

Investigate the problem

Identify the cause of the problem based on the collected data. Isolate the problem or all the areas affected by the problem.

7.2 Troubleshooting procedures

This section describes how to troubleshoot Performance Management. If a problem occurs while you are using Performance Management, first check for any of the events described in this section.

The following table shows the main types of problems that may occur in Performance Management.

Table 7–1: Table Problems that occur in Performance Management

Category	Description	Reference
Problems relating to the start and setup of services	<ul style="list-style-type: none"> • A Performance Management program service does not start. • There is a delay from the time the start request is issued until the service starts. • Communication fails when another program starts a service immediately after a Performance Management program service is stopped. • The following message is output and the Master Store or Agent Store service stops: <code>The disk capacity is insufficient.</code> • Agent Collector service of the PFM - Agent does not start. 	See the chapter that explains troubleshooting in the <i>JPI/Performance Management User's Guide</i> .
Problems relating to command execution	<ul style="list-style-type: none"> • The name of an inactive service is output when you execute the <code>jpctool service list</code> command. • The data output by the <code>jpctool db dump</code> command is not the Store data you specified. 	
Problems relating to report definitions	<ul style="list-style-type: none"> • During a certain period, the collected data is not shown in the historical report. 	
Problems relating to alarm definitions	<ul style="list-style-type: none"> • A program defined in an action does not operate correctly. • Alarm events are not displayed. • Although the alarm threshold has been exceeded, the color of the alarm icon shown in the Alarm Status window of the Agents tree remains green. 	
Problems relating to collection and management of performance data	<ul style="list-style-type: none"> • The PFM - Agent for Microsoft SQL Server Store database remains large despite setting a short retention period. • The following message is output to the common message log: <code>Illegal data was detected in the Store database.</code> 	
	<ul style="list-style-type: none"> • Performance data is not collected after PFM - Agent for Microsoft SQL Server startup. 	7.2.1

7.2.1 Problems relating to the collection and management of performance data

This subsection describes how to correct errors related to the collection and management of performance data in Performance Management. For details about how to correct other types of errors, see the *JPI/Performance Management User's Guide*.

(1) Performance data is not collected after PFM - Agent for Microsoft SQL Server startup

Take the following action:

- Check the startup status of the Microsoft SQL Server and start it if it is inactive.
- Check the instance environment settings.

Execute the `jpcconf inst setup` command to specify the correct value for each item. For details about the `jpcconf inst setup` command, see the chapter that describes commands in the manual *JP1/Performance Management Reference*.

- If PFM - Agent for Microsoft SQL Server runs on a logical host and port numbers for Microsoft SQL Server are set to other than standard, you need to set 64-bit name for [Aliases] by using, for example, an SQL Server configuration manager.

In PFM - Agent for Microsoft SQL Server version 11-50 or later, specify a 64-bit alias by using SQL Server Client Network Utility or any other tool.

In version 11-10 or earlier, you need to specify a 32-bit alias, but in version 11-50 or later, the settings have been changed. For this reason, special attention is required for upgrading version 11-10 or earlier.

For details about alias setting, see 3.3.2(5) Notes when a non-default Microsoft SQL Server port number.

7.2.2 Other problems

Check what events occur when the problem is encountered. If a message has been output, check the contents of the message. For details about the log information output by Performance Management, see *7.3 Log information*.

If the actions described in chapter on troubleshooting in the *JP1/Performance User's Guide* and sections *7.2.1 Problems relating to the collection and management of performance data* do not resolve the problem, or the problem arises in a different scenario, collect information to determine the cause of the problem, and contact the system administrator.

For details about the data you need to collect and how to collect it, see *7.4 Required troubleshooting information* and *7.5 Collecting troubleshooting information*.

7.3 Log information

You can determine what action to take when a problem occurs in Performance Management by reviewing the log information. Five types of log information are output during Performance Management operation:

- System log
- Common message log
- Operation status log
- Trace log
- Agent log

This section explains each type of log information.

7.3.1 Types of log information

(1) System log

A system log contains log information that describes the system status and reports errors in the system. System logs are output to the following log files:

- In Windows
Event log file

For details about the output format, see the chapter on log information in the manual *JPI/Performance Management Reference*.

Cautionary note on logical host use

In addition to the system log for Performance Management, logs for the cluster software are required. Use these logs to check the instructions issued to Performance Management by the cluster software.

(2) Common message log

The common message log contains log information that describes the system status and reports errors in the system. The common message log contains information that is more detailed than that in the system log. For details about the output file name and file size of the common message log, see [7.3.2 List of log files and directories](#). For details about the output format of the common message log, see the chapter on log information in the manual *JPI/Performance Management Reference*.

Cautionary note on logical host use

When Performance Management is set up for logical host use, the common message log is output to a shared disk and inherited at failover. This means that the messages are recorded in the same log file before and after failover.

(3) Operation status log

The operation status log contains log information output by PFM - Web Console. For details about the output file name and file size of the operation status log, see the chapter on troubleshooting in the *JPI/Performance User's Guide*. For details about the output format of the operation status log, see the chapter on log information in the manual *JPI/Performance Management Reference*.

(4) Trace log

A trace log contains log information that helps you investigate the status of the system leading up to the problem, and measure the processing time for each process.

Trace logs are output to the log files belonging to each Performance Management service.

Cautionary note on logical host use:

When Performance Management is set up for logical host use, trace logs are output to the shared disk and inherited at failover. This means that the messages are recorded in the same log file before and after failover.

(5) Agent log

An agent log that is output by PFM - Agent for Microsoft SQL Server contains log information about the processing executed to acquire records. If a problem occurs, collect agent logs to acquire detailed information about the processing.

Agent logs are output to separate files according to its type: normal log or error log. For details about output destinations, see [7.3.2\(3\) Agent log](#).

Format:

The format of an output agent log is as follows:

```
yyyy/mm/dd hh:mm:ss.sss agtq PID inf1 inf2 inf3 MessageID Message
```

The following explains the output items.

Table 7–2: Agent log items

Item	Description
<i>yyyy/mm/dd</i>	Date on which the log was output (<i>yyyy</i> : year, <i>mm</i> : month, and <i>dd</i> : day)
<i>hh:mm:ss.sss</i>	Local time at which the log was output (<i>hh</i> : hour, <i>mm</i> : minute, <i>ss</i> : second, and <i>sss</i> : millisecond)
<i>agtq</i>	Name of the process that output the log (<i>agtq</i> is the process name of PFM - Agent for Microsoft SQL Server).
<i>PID</i>	Output process ID
<i>inf1 to inf3</i>	Maintenance information
<i>MessageID</i>	Message ID [#]
<i>Message</i>	Message [#]

#

For details about the message contents, see [6. Messages](#).

Notes

- Do not change the time set on the Agent host or the update time of an agent log file. Since information about the last update date and time is used to output agent logs, the agent logs may not be output correctly if these times are changed.
- When Performance Management is set up for logical host use, specify a path on the shared disk so that the agent log output destination is the same for both the executing node and the standby node.

7.3.2 List of log files and directories

This subsection describes the log information output by a Performance Management program. Performance Management outputs the following log information:

For details about the output file name and file size of the operation status log, see the chapter on troubleshooting in the *JPI/Performance Management User's Guide*.

(1) Common message log

This subsection describes the common message log output by Performance Management. The following tables show the name of the service or command that outputs the log, the name of the log file, and the disk space used by each file, for each OS.

Table 7–3: Common message log file names

Type of log	Output source	File name	Disk usage ^{#1} (KB)
Common message log	Performance Management	<i>installation-folder</i> \log\jpclog{01 02} ^{#2}	2,048 (x2)
		<i>installation-folder</i> \log\jpclogw{01 02} ^{#2}	2,048 (x2)
Common message log (logical host use)	Performance Management on logical host	<i>environment-directory</i> ^{#3} \jplpc\log\jpclog{01 02} ^{#2}	2,048 (x2)
		<i>environment-directory</i> ^{#3} \jplpc\log\jpclogw{01 02} ^{#2}	2,048 (x2)

#1

The number enclosed in brackets indicates the number of log files created for the service. For example, if the disk usage is 2,048 (x2), Performance Management creates one or two log files, each taking up a maximum of 2,048 kilobytes of disk space. In this case, the total disk usage will be 4,096 KB.

#2

Common message log files are suffixed with 01 or 02.

When using sequential files (jpclog)

Initially, log information is output to a log file with the suffix 01. When the log file reaches the maximum size, its suffix is changed from 01 to 02, and a new log file is created with the suffix 01. Subsequent log information is output to the new log file. If a log file with the suffix 02 already exists, it is overwritten. The latest log information is always output to the log file with the suffix 01.

When using wraparound files (jpclogw)

Initially, log information is output to a log file with the suffix 01. When the log file reaches the maximum size, a new log file is created with the suffix 02. Subsequent log information is output to the new log file. If a log file with the suffix 02 already exists, the entire contents of the file are deleted, and new log information is added from the top of the file. Performance Management then alternates between the two files as each fills with data.

For details about the output format of the log files, see the chapter on detecting errors in Performance Management in the *JPI/Performance Management User's Guide*.

#3

The environment directory is the directory you specified on the shared disk when creating the logical host.

(2) Trace log

This subsection describes the trace logs output by Performance Management. The following tables list the name of the service or command that outputs trace logs for PFM - Agent for Microsoft SQL Server and the directory where the logs are stored, for each OS.

Table 7–4: Trace log storage folders

Type of log	Output source	Folder name
Trace log	Action Handler service	<i>installation-folder</i> \bin\action\log\
	Performance Management command	<i>installation-folder</i> \tools\log\
	Agent Collector service	<i>installation-folder</i> \agtq\agent\ <i>instance-name</i> \log\
	Agent Store service	<i>installation-folder</i> \agtq\store\ <i>instance-name</i> \log\
	Status Server service	<i>installation-folder</i> \bin\statsvr\log\
Trace log (logical host use)	Action Handler service	<i>environment-directory</i> #\jp1pc\bin\action\log\
	Performance Management command	<i>environment-directory</i> #\jp1pc\tools\log\
	Agent Collector service	<i>environment-directory</i> #\jp1pc\agtq\agent\ <i>instance-name</i> \log\
	Agent Store service	<i>environment-directory</i> #\jp1pc\agtq\store\ <i>instance-name</i> \log\

#

The environment directory is the directory you specified on the shared disk when creating the logical host.

(3) Agent log

This subsection describes the agent logs output by Performance Management. The following tables list the name of the service or command that outputs agent logs for PFM - Agent for Microsoft SQL Server, the name of the log file, and the disk space used by each file.

Table 7–5: Agent log files

Type of log	Output source	Default output destination ^{#1}	File name	Default Disk usage ^{#1} (MB)
Normal log	PFM - Agent for Microsoft SQL Server	<i>installation-folder</i> \agtq\agent\ <i>instance-name</i> \log\	agtqinf{01 02} ^{#2}	16
Error log			agtqerr{01 02} ^{#2}	
Normal log (logical host use)	PFM - Agent for Microsoft SQL Server	<i>environment-directory</i> ^{#3} \jp1pc\agtq\agent\ <i>instance-name</i> \log\	agtqinf{01 02} ^{#2}	16
Error log (logical host use)			agtqerr{01 02} ^{#2}	

#1

You can use the following methods to check and change the output destination of agent logs and the maximum file size:

- `jpcconf inst setup` command
- Agent Configuration property in the PFM - Web Console window

For details about how to use the `jpcconf inst setup` command to change the settings, see [2.4.2 Updating an instance environment](#).

#2

Agent logs are output using two sequential files. The file names are suffixed with 01 or 02, which have the following meanings:

- 01: Current file
- 02: Backup file

For details about sequential files, see *When using sequential files (jpclog) in (1) Common message log*.

#3

The environment directory is on the shared disk specified when the logical host was created.

7.4 Required troubleshooting information

If the actions described in *7.2 Troubleshooting procedures* do not resolve the problem, collect information to determine the cause of the problem, and then contact the system administrator. This section describes the information you need to collect when an error occurs.

Performance Management provides the `jpcras` command to collect the required information in a batch. Use this command to collect information about PFM - Agent for Microsoft SQL Server. In the following tables, the information that can be collected by the `jpcras` command is indicated as such.

Note:

The data collected by the `jpcras` command depends on the options specified when the command was executed. For details about the command options and the data that can be collected, see the chapter on commands in the manual *JP1/Performance Management Reference*.

Cautionary notes on logical host use:

- When running in a logical host environment, Performance Management outputs logs to a shared disk. If the shared disk is online when you execute the `jpcras` command, the logs on the shared disk are also collected.
- To investigate the cause of a problem that occurred during failover, you will need information from before and after the failover. For this reason, you must collect information from both the executing node and the standby node.
- When Performance Management is running in a logical host environment, you must also collect information for the cluster software. Because Performance Management is started and stopped by the cluster software in a logical host environment, collecting this information allows you to check the behavior of Performance Management against the behavior of the cluster software.

7.4.1 In Windows

(1) Log information about the OS

Collect the information about the OS. Table 7-6 lists the information about the OS.

Table 7–6: Information about the OS

Type of information	Details	Default file name	Collected by jpcras command
System log	Windows event log	--	Y
Process information	List of processes	--	Y
System file	hosts file	<i>system-folder</i> \system32\drivers\etc\hosts	Y
	services file	<i>system-folder</i> \system32\drivers\etc\services	Y
OS information	System information	--	Y
	Network status	--	Y

Type of information	Details	Default file name	Collected by jpcras command
OS information	Host name	--	Y
	Windows firewall information	--	Y
Dump information	Problem Reports and Solutions log file	<i>user-mode-process-dump-output-folder\program-name.process-ID.dmp</i> Example: <i>jpcagtq.exe.2420.dmp</i>	N

Legend:

Y: Can be collected

N: Cannot be collected

--: Not applicable

#

If you set up Dr. Watson to output log files to a different folder, collect the information from that folder.

(2) Performance Management information

Collect the log information about Performance Management. If the problem relates to a network connection, also collect information from the machine that is the connection target. Table 7-7 lists the log information about the Performance Management:

Table 7–7: Log information about Performance Management

Type of information	Details	Default file name	Collected by jpcras command
Common message log	Message log output by Performance Management (sequential files)	<i>installation-folder\log\jpclog{01 02}#1</i>	Y
	Message log output by Performance Management (wraparound files)	<i>installation-folder\log\jpclogw{01 02}#1</i>	Y
Configuration information	Configuration information files	--	Y
	Output of <code>jpc tool service list</code> command	--	Y
Version information	Product versions	--	Y
	Log information	--	Y
Database information	Agent Store service	<ul style="list-style-type: none"> For Store 1.0 <i>installation-folder\agtq\store*.DB</i> <i>installation-folder\agtq\store*.IDX</i> For Store 2.0 <i>installation-folder\agtq\store\instance-name\STPD</i> <i>installation-folder\agtq\store\instance-name\STPI</i> folder: <i>*.DB</i> 	Y

Type of information	Details	Default file name	Collected by jpcras command
Database information	Agent Store service	*.IDX	Y
Trace log	Trace information for Performance Management services	..#2	Y
Agent log	Normal log for processing related to acquisition of PFM - Agent for Microsoft SQL Server records	<i>installation-folder</i> \agtq\agent\ <i>instance-name</i> \log\agtqinf{01 02}#3	Y#4
	Error log for processing related to acquisition of PFM - Agent for Microsoft SQL Server records	<i>installation-folder</i> \agtq\agent\ <i>instance-name</i> \log\agtqerr{01 02}#3	Y#4
Install log#5	Message logs from installation	The following files under the <i>system-folder</i> \TEMP\HCDINST folder: <ul style="list-style-type: none"> • HCDMAIN.LOG and HCDMAINn.LOG#6 • HCDINST.LOG and HCDINSTn.LOG#6 • <i>product-model-name</i>.LOG 	N

Legend:

- Y: Can be collected
- N: Cannot be collected
- : Not applicable

#1

For details about the output format of the log files, see the chapter on detecting errors in Performance Management in the *JPI/Performance Management User's Guide*.

#2

For details about the trace log storage destination folder, see [7.3.2\(2\) Trace log](#).

#3

For details about the output format of an agent log and how to change the storage folder, see [7.3.2\(3\) Agent log](#).

#4

The `jpcras` command collects agent log information only from the currently specified output destination folder. If you change the output destination folder for agent logs, you need to manually collect data from the agent log files that were output before the change.

#5

Collect this information if installation failed.

#6

n indicates number

(3) Operation information

Collect the following information about the operation that was being performed when the problem occurred:

- Details of the operation

- Time when the error occurred
- Machine configuration (version of each OS, host name, configuration of PFM - Manager and PFM - Agent for Microsoft SQL Server)
- Whether the error is reproducible
- Name of any Performance Management user who logged in from PFM - Web Console
- The argument specified for the command if the error occurred during command execution

(4) Error information on the screen

Collect hard copies of the following:

- Windows on the screen when the application error occurred
- The error dialog boxes (Also copy the detailed information if a dialog box contains a **Details** button.)
- Information in the Command Prompt window or **Administrator Console** window when an error occurs during command execution

(5) User mode process dump

If a Performance Management process stops due to an application error, obtain a user mode process dump.

(6) Collecting problem reports

If a Performance Management process stops due to an application error, obtain a problem report.

(7) Other information

The following types of information are also necessary:

- Contents of **System** and **Application** in the Windows Event Viewer window
- Content of **System Information** under **System Tools** under **Accessories**

7.5 Collecting troubleshooting information

This section describes how to collect information when an error occurs.

7.5.1 In Windows

(1) Collecting dump information

To collect dump information:

1. Open Task Manager.
2. Select the process tab.
3. Right-click the process name for which you want to collect dump information, and then select **Create Dump File**.
Dump files are stored in the following folder:

```
system-drive\Users\user-name\AppData\Local\Temp
```

4. Obtain the dump file from the folder created in step 3.
If you have changed the environment variable settings so that dump files are output to a different folder, obtain the dump file from that folder.

(2) Execute the data collection command

To collect data for investigating the cause of the error, you use the `jpccras` command. The procedure for executing the data collection command is described below. Note that the operations explained here must be executed by a user who has the Administrators permission as an OS user.

To collect data:

1. Log onto the host on which the service whose data is to be collected is installed.
2. At the command prompt, execute the following command and enable the command extended function of the command interpreter.

```
cmd /E:ON
```

3. Specify the data to be collected and the folder for storing it, and execute the `jpccras` command.
In the example shown below, all information that can be collected using the `jpccras` command is stored in the folder `c:\tmp\jpc\agt`.

```
jpccras c:\tmp\jpc\agt all all
```

When the `jpccras` command is executed, the `jpctool service list -id * -host *` command is executed internally to obtain a list of PFM services and to confirm whether the services are running. Execution of this internal command might take a long time if a firewall exists between the host that executes the command and a host in another Performance Management system or if the system configuration is large. In either case, you can set the `JPC_COLCTRLNOHOST` environment variable to 1 to suppress processing of the `jpctool service list -id * -host *` command to shorten the command execution time.

For details about the `jpccras` command, see the chapter on commands in the manual *JPI/Performance Management Reference*.

(3) Execute the data collection command (for logical host use)

When you run Performance Management in a logical host environment, the data is stored on a shared disk. In this case, collect data from both the executing node and the standby node.

Use the `jpccras` command to collect the information needed to investigate an error. The following procedure shows how to execute the data collection command. Note that you must perform these operations as an OS user who belongs to the Administrators group.

To execute the data collection command in a logical host environment:

1. Bring the shared disk online.

For logical hosts, data is stored on a shared disk. On the executing node, make sure that the shared disk is online before collecting data.

2. Execute the `jpccras` command on both the executing node and the standby node, specifying the data to collect and the folder in which to store it.

For example, to have the `jpccras` command store all collectible data in the folder `c:\tmp\jpc\agt`, specify the command as follows:

```
jpccras c:\tmp\jpc\agt all all
```

If you execute the `jpccras` command without specifying the `lhost` argument, data relating to Performance Management is collected from all physical and logical hosts on that node. If any Performance Management programs are running in a logical host environment, the log files will be collected from the shared disk.

If the shared disk is offline for the node on which you execute the `jpccras` command, you will be unable to acquire the files on the shared disk. However, the command will end normally without generating an error.

Note

You need to collect data from both the executing node and standby node by executing the data collection command on each node. Data from both nodes is required to investigate the status of the system leading up to and following failover.

When the `jpccras` command is executed, the `jpctool service list -id * -host *` command is executed internally to obtain a list of PFM services and to confirm whether the services are running. Execution of this internal command might take a long time if a firewall exists between the host that executes the command and a host in another Performance Management system or if the system configuration is large. In either case, you can set the `JPC_COLCTRLNOHOST` environment variable to 1 to suppress processing of the `jpctool service list -id * -host *` command to shorten the command execution time.

For details about the `jpccras` command, see the chapter on commands in the manual *JPI/Performance Management Reference*.

3. Collect data about the cluster software.

This data is required to determine whether a problem is caused by Performance Management or the cluster software. Collect data from which you can determine the results of any instructions, such as start and stop requests that the cluster software issued to Performance Management.

(4) Obtaining the Windows event log

Get the contents of **System** and **Application** in the Windows Event Viewer window.

(5) Check the operation information

If an error occurs while an operation is being performed, check and record information about the operation. Check the following information:

- Details of the operation
- The time when the error occurred
- Machine configuration (version of each OS, host name, configuration of PFM - Manager and PFM - Agent for Microsoft SQL Server)
- Whether the error is reproducible
- Name of any Performance Management user who logged in from PFM - Web Console
- The argument specified for the command if the error occurred during command execution

(6) Collect error information displayed on the screen

Collect hard copies of the following:

- Windows on the screen when the application error occurred
- The error dialog boxes
Also copy the detailed information if the dialog box contains a **Details** button.
- Hard copy of the **Command Prompt** window or **Administrator Console** window if a problem occurred during command execution

To obtain a hard copy of the **Command Prompt** window specify the following in the **Command Prompt Properties** window:

- **Edit Options** under the **Options** tab
Select **Quick Edit Mode**.
- **Layout** tab
Set **Height** under **Screen Buffer Size** to 500.

(7) Collecting other information

Information to be collected for all OSs

Contents of the dialog box displayed by choosing **Accessories**, **System Tools**, and then **System Information**

7.6 Detecting errors in Performance Management

Performance Management provides a status management facility that allows you to check the status of Performance Management itself when an error occurs. This facility monitors the operating status of PFM - Agent for Microsoft SQL Server and PFM - Agent host and reports these operating statuses on the PFM - Web Console.

By using PFM service automatic restart facility, you can automatically restart PFM services when PFM services abnormally end, or you can regularly restart PFM services.

When you monitor the operating status of PFM - Agent for Microsoft SQL Server or automatically restart PFM services, use *the status management facility*, which checks the detailed status of Performance Management services. As a result, it is required that the version number of PFM - Agent for Microsoft SQL Server you are using supports the status maintenance facility and that you enable it. Note that there are no prerequisites for monitoring the PFM - Agent hosts.

Alternatively, you can use JP1/Base, an integrated system monitor, to monitor the log file of Performance Management so that you can detect errors in Performance Management. By using these facilities, the system administrator can detect errors when they occur, identify the cause of them, and then take the appropriate action to recover from them.

For details about detecting errors in Performance Management itself, see the chapter on error detection in Performance Management in the *JP1/Performance Management User's Guide*.

7.7 Recovering from errors in Performance Management system

When an error occurs on a Performance Management server, you must use backup files to restore the system to a normal state before the error occurred.

For details about how to do so, see the chapter on troubleshooting in the *JP1/Performance Management User's Guide*.

Appendixes

A. Estimating System Requirements

We recommend that you estimate in advance whether the computer to be configured in your PFM - Agent for Microsoft SQL Server system has sufficient processing capacity to run the program.

A.1 Memory requirements

Memory requirements depend on how PFM - Agent for Microsoft SQL Server is set up and used.

For details about the formula for estimating memory requirements, see the *Release Notes*.

A.2 Disk space requirements

Disk space requirements depend on the number of records used to collect performance data. When estimating the amount of disk space required, note that the estimated disk space required for the entire system is a function of the estimated disk space required for the Store database (version 1.0 or 2.0). For the equations to use to estimate disk space requirements, see the Release Notes.

A.3 Disk space requirements for operation in a cluster system

The disk space requirements for operation in a cluster system are estimated in the same way as for operation on a single node. For details about the disk space requirements, see the *Release Notes*.

A.4 Calculating the number of instances for records

The following table shows how to calculate the number of instances for each record collected by PFM - Agent for Microsoft SQL server.

Use `sqlcmd` or a similar program to access the Microsoft SQL Server to be monitored, and execute an SQL statement to obtain the number of instances. If a calculation method for the target record is provided in the table, use that method.

To use `osql` to obtain the number of instances:

1. Start `sqlcmd`.
2. As a user who has the following privilege, connect to the Microsoft SQL Server to be monitored:
- `sysadmin`
3. For the record for which you want to check the number of instances, execute the SQL statement shown in Table A-1.



Important

Note

The number of instances is used as dynamic information about the monitored Microsoft SQL Server. Since the number of instances dynamically changes due to factors such as the number of connections

with the monitored Microsoft SQL Server, use the maximum of the obtained values for your estimate.

Table A–1: Calculating the number of instances for records

Record	SQL statements that obtains the number of instances, and calculation method
PI	The number of instances is 1.
PI_PI2	The number of instances is 1.
PI_DI	SQL Server version 2014 or earlier: <pre>SELECT count (*) FROM master..sysdatabases</pre> SQL Server version 2016 or later: <pre>SELECT count (*) FROM master.sys.databases</pre>
PI_ESI#1	The number of instances is 0.
PI_GENI#1	The number of instances is 0.
PI_RPDB	Number of the environment setting options shown in the result set when you execute the sp_replcounters system stored procedure.
PI_SERV	The number of instances is 1.
PI_SRV2	The number of instances is 1.
PI_SI	The number of instances is 1.
PI_TLOG	Number of the environment setting options shown in the result set when you execute the DBCC SQLPERF (LOGSPACE) statement.
PI_UCTR	The number of instances is 1.
PD	The number of instances is 1.
PD_CD	Number of the environment setting options shown in the result set when you execute the sp_configure system stored procedure.
PD_DD	SQL Server version 2014 or earlier: <pre>SELECT count (*) FROM master..sysdatabases</pre> SQL Server version 2016 or later: <pre>SELECT count (*) FROM master.sys.databases</pre>
PD_DS	SQL Server version 2014 or earlier: <pre>SELECT count (*) FROM master..sysdatabases</pre> SQL Server version 2016 or later: <pre>SELECT count (*) FROM master.sys.databases</pre>
PD_EE	Number of the following messages that are written to the SQL Server error log at the collection interval specified for the PD_EE record: <ul style="list-style-type: none"> • - Japanese Windows, English Windows, Shimplied Chinese Windows: • The word is equal to Error in each language • - Other language Windows: • The number of instances is 0. • The number of errors by the collecion method of PD_EE record is as follows. • - When collect historical or evaluate an alarm: • The value of instance information "LIMIT_PD_EE_NUMBER" and the number of errors written in at error log of SQL Server after last collection time either small one. • - When display real-time report:

Record	SQL statements that obtains the number of instances, and calculation method
PD_EE	<ul style="list-style-type: none"> The number of errors written in at error log of SQL Server. The SQL Server error log is the error log file for the monitored SQL Server instance specified in <code>SQL_ERRORLOG</code>.
PD_ES	The number of instances is 1.
PD_GEND#1	The number of instances is 0.
PD_IA	The number of instances is 1.
PD_JH	<pre>SELECT count(*) FROM msdb..sysjobhistory a LEFT JOIN msdb..sysjobsteps b ON a.job_id = b.job_id AND a.step_id = b.step_id</pre>
PD_LD	<p>SQL Server version 2014 or earlier:</p> <pre>SELECT count(*) FROM master..syslockinfo</pre> <p>SQL Server version 2016 or later:</p> <pre>SELECT count(*) FROM master.sys.dm_tran_locks</pre>
PD_LIC	The number of instances is 1.
PD_LOCK	The number of instances is 1.
PD_PCAC	The number of instances is 1.
PD_PDES	The number of instances is 0.
PD_PDET	<p>SQL Server version 2014 or earlier:</p> <pre>SELECT count(*) FROM (master..sysprocesses a LEFT JOIN master..syslogins b ON a.sid = b.sid) LEFT JOIN master..sysusers c ON a.sid = c.sid</pre> <p>SQL Server version 2016 or later:</p> <pre>SELECT count(*) FROM master.sys.dm_exec_sessions a LEFT JOIN master.sys.server_principals b ON a.security_id = b.sid</pre>
PD_RD	<p>Execute the following SQL statement:</p> <pre>USE distribution EXEC sp_tables MSdistribution_history, dbo</pre> <ul style="list-style-type: none"> - If the error "Message 911, Level 16" occurs, the number of instances is 0. - If the SQL statement executed successfully and the result is 0, the number of instances is 0. - If the SQL statement executed successfully and the result is 1, the number of instances is the execution result of the following statement: <p>SQL Server version 2014 or earlier:</p> <pre>SELECT count(*) FROM master..sysdatabases</pre> <p>SQL Server version 2016 or later:</p> <pre>SELECT count(*) FROM master.sys.databases</pre>
PD_RH#1	The number of instances is 0.
PD_RS	<p>Execute the following SQL statement:</p> <pre>1. USE distribution EXEC sp_tables MSdistribution_history, dbo</pre> <ul style="list-style-type: none"> - If the error "message 911, level 16" occurs, the number of instances is 0. - If the SQL statement executed successfully and the result is 0, the number of instances is 0. - If the SQL statement executed successfully and the result is 1, the number of instances is 1.

Record	SQL statements that obtains the number of instances, and calculation method
PD_SQL ^{#2}	The number of instances is 0.
PD_SS	The number of instances is 1.
PD_USER	<p>SQL Server version 2014 or earlier:</p> <pre>SELECT count (*) FROM (master..sysprocesses a LEFT JOIN master..syslogins b ON a.sid = b.sid) LEFT JOIN master..sysusers c ON a.sid = c.sid</pre> <p>SQL Server version 2016 or later:</p> <pre>SELECT count (*) FROM master.sys.dm_exec_sessions a LEFT JOIN master.sys.server_principals b ON a.security_id = b.sid</pre>

#1

This record is a reserved record and cannot be used.

#2

This record can only be used in real time.

B. List of Identifiers

When you operate PFM - Agent for Microsoft SQL Server or extract performance data from its Store database, you may require an identifier of PFM - Agent for Microsoft SQL Server. The following table describes the PFM - Agent for Microsoft SQL Server identifiers.

Table B–1: List of PFM - Agent for Microsoft SQL Server identifiers

Use	Name	Identifier	Description
Command	Product ID	Q	The product ID is part of the service ID required when using a command to check the Performance Management system configuration or to back up performance data. For details about service IDs, see the naming rules described in the appendix in the <i>JP1/Performance Management Planning and Configuration Guide</i> .
	Service key	agtq or SQL	A service key is required when using a command to start or stop PFM - Agent for Microsoft SQL Server. For details about service keys, see the naming rules described in the appendix in the <i>JP1/Performance Management Planning and Configuration Guide</i> .
Help	Help ID	pcaq	The help ID indicates that the help is for PFM - Agent for Microsoft SQL Server.

C. List of Processes

This appendix describes the processes of PFM - Agent for Microsoft SQL Server.

The following table lists the PFM - Agent for Microsoft SQL Server process. The value following the process name is the number of processes that can be started concurrently.

Note:

The process and limit numbers are identical whether PFM - Agent for Microsoft SQL Server on a physical host or logical host.

Table C–1: Processes of PFM - Agent for Microsoft SQL Server

Process name (Process count)	Function
jpcagtq.exe(n)	The process of the Agent Collector service. One process is started for each instance of PFM - Agent for Microsoft SQL Server.
jpcsto.exe(n)	The process of the Agent Store service. One process is started for each instance of PFM - Agent for Microsoft SQL Server.
stpqlpr.exe(1) [#]	The process for backup or export of the Store database

#

This process is a child process of the `jpcsto.exe` process.

D. List of Port Numbers

This appendix lists the port numbers used by PFM - Agent for Microsoft SQL Server.

For details about the port numbers and firewall routing in PFM - Manager and PFM - Base, see the appendixes in the manual *JPI/Performance Management Reference*.

The port numbers can be changed to suit the user environment.

For details about changing a port number, see the chapter on installation and setup in the *JPI/Performance Management Planning and Configuration Guide*. The TCP/IP protocol is used.

Note:

Performance Management supports network address translation in static mode (Basic NAT), which provides one-to-one address mapping.

Performance Management does not support dynamic NAT or NATP containing port translations (IP Masquerade and NAT+).

D.1 Port numbers for PFM - Agent for Microsoft SQL Server

The following table shows the port numbers used by PFM - Agent for Microsoft SQL Server.

Table D–1: Port numbers used by PFM - Agent for Microsoft SQL Server

Port number	Service name	Parameter	Use
Automatic ^{#1}	Agent Store service	jp1pcstoq[<i>nnn</i>] ^{#2}	Used for recording performance data or acquiring a historical report
Automatic ^{#1}	Agent Collector service	jp1pcagtq[<i>nnn</i>] ^{#2}	Used for binding an alarm or acquiring a real-time report

#1

A port number not already being used by the system is assigned automatically every time the service is restarted.

#2

When multiple instances are created, a sequential number (*nnn*) is appended to the second and subsequent instances. The first instance does not have a sequential number.

D.2 Routing through a firewall

If PFM - Manager and PFM - Agent for Microsoft SQL Server communicate across a firewall, set fixed port numbers for all PFM - Manager and PFM - Agent for Microsoft SQL Server ports. Set the port numbers in the directions shown in the table below so that all the services can route through the firewall.

For more details, see the section describing the firewall passage direction in the manual *JPI/Performance Management Reference*.

E. PFM - Agent for Microsoft SQL Server Properties

This appendix lists the properties of the Agent Store and Agent Collector services of PFM - Agent for Microsoft SQL Server that are displayed on PFM - Web Console.

E.1 List of Agent Store service properties

The following table lists the properties for the Agent Store service of PFM - Agent for Microsoft SQL Server.

Table E–1: List of Agent Store service properties of PFM - Agent for Microsoft SQL Server

Folder name	Property name	Description
--	First Registration Date	Displays the date and time on which the service was first recognized by PFM - Manager.
	Last Registration Date	Displays the date and time on which the service was last recognized by PFM - Manager.
General	--	Stores information such as the host name and directories. The properties in this folder cannot be changed.
	Directory	Displays the name of the current directory where the service runs.
	Host Name	Displays the name of the physical host on which the service runs.
	Process ID	Displays the process ID of the service.
	Physical Address	Displays the IP address and port number of the host on which the service runs when IPv6 communication is disabled.
	Physical Address(IPv4)	Displays the IP address (IPv4) of the host on which the service runs when IPv6 communication is enabled.
	Physical Address(IPv6)	Displays the IP address (IPv6) of the host on which the service runs when IPv6 communication is enabled.
	Port Number	Displays the port number on which the service runs when IPv6 communication is enabled.
	User Name	Displays the name of the user who executed the service process.
	Time Zone	Displays the time zone in which the service was used.
System	--	Stores information about the OS under which the service runs. The properties in this folder cannot be changed.
	CPU Type	Displays the CPU type.
	Hardware ID	Displays the hardware ID.
	OS Type	Displays the type of OS.
	OS Name	Displays the name of the OS.
	OS Version	Displays the version of the OS.
Network Services	--	Stores information about the common library for Performance Management communication. The properties in this folder cannot be changed.
	Build Date	Displays the date on which the Agent Store service was created.
	INI File	Displays the directory containing the <code>jpcons.ini</code> file.

Folder name		Property name	Description
Network Services	Service	--	Stores information about the service. The properties in this folder cannot be changed.
		Description	Displays the host name in the following format: <i>instance-name_host-name</i>
		Local Service Name	Displays the service ID.
		Remote Service Name	Displays the service ID of the Master Manager service on the connection-target PFM - Manager host.
		EP Service Name	Displays the service ID of the Correlator service on the connection-target PFM - Manager host.
Retention	--	Sets the data retention period when the Store version is 1.0. For details, see the chapter on management of operation monitoring data in the <i>JP1/Performance Management User's Guide</i> .	
	Product Interval - Minute Drawer	Specifies the minute-by-minute record retention period for PI-type records. One of the following can be selected: <ul style="list-style-type: none"> • Minute • Hour • Day • 2 Day • 3 Day • 4 Day • 5 Day • 6 Day • Week • Month • Year 	
	Product Interval - Hour Drawer	Specifies the hourly record retention period for PI-type records. One of the following can be selected: <ul style="list-style-type: none"> • Hour • Day • 2 Day • 3 Day • 4 Day • 5 Day • 6 Day • Week • Month • Year 	
	Product Interval - Day Drawer	Specifies the daily record retention period for PI-type records. One of the following can be selected: <ul style="list-style-type: none"> • Day • 2 Day • 3 Day • 4 Day • 5 Day • 6 Day • Week • Month • Year 	

Folder name		Property name	Description
Retention		Product Interval - Week Drawer	Specifies the weekly record retention period for PI-type records. One of the following can be selected: <ul style="list-style-type: none"> • Week • Month • Year
		Product Interval - Month Drawer	Specifies the monthly record retention period for PI-type records. One of the following can be selected: <ul style="list-style-type: none"> • Month • Year
		Product Interval - Year Drawer	Specifies the yearly record retention period for PI-type records. Fixed to Year.
		Product Detail - record-ID-of-PD-record-type	Specifies the number of records retained for each PD-type record. An integer in the range from 0 to 2,147,483,647 can be specified. Note: If an invalid numerical value or a character such as a letter is specified, an error message is displayed.
Retention Ex		--	Sets the data retention period when the Store version is 2.0. For details, see the chapter that describes management of operation monitoring data in the <i>JPI/Performance Management User's Guide</i> .
Retention Ex	Product Interval - record-ID-of-PI-record-type	--	Sets the retention period for records of the PI record type.
		Period - Minute Drawer (Day)	Sets the retention period for records of the PI record type per minute. Values from 0 to 366 days can be specified, on a daily basis.
		Period - Hour Drawer (Day)	Sets the retention period for records of the PI record type per hour. Values from 0 to 366 days can be specified, on a daily basis.
		Period - Day Drawer (Week)	Sets the retention period for records of the PI record type per day. Values from 0 to 522 weeks can be specified, on a weekly basis.
		Period - Week Drawer (Week)	Sets the retention period for records of the PI record type per week. Values from 0 to 522 weeks can be specified, on a weekly basis.
		Period - Month Drawer (Month)	Sets the retention period for records of the PI record type per month. Values from 0 to 120 months can be specified, on a monthly basis.
		Period - Year Drawer (Year)	Sets the retention period for records of the PI record type per year. This is fixed at 10.
	Product Detail - record-ID-of-PD-record-type	Period (Day)	Sets the retention period for each ID for records of the PD record type. Retention periods can be set as an integer from 0 to 366, in days.
Disk Usage		--	This folder contains information for disk space used by each database. The values in this folder are those current at the time the properties are displayed. The properties in this folder cannot be changed.
		Product Interval	Displays the disk space used by the records of PI record type
		Product Detail	Displays the disk space used by the records of PD record type
		Product Alarm	Displays the disk space used by the records of PA record type. This property is not used in PFM - Agent for Microsoft SQL Server.
		Product Log	Displays the disk space used by the records of PL record type. This property is not used in PFM - Agent for Microsoft SQL Server.
		Total Disk Usage	Displays the total disk space used by the entire database.

Folder name	Property name	Description
Configuration	--	Displays the property of the Agent Store service.
	Store Version	Shows the Store database version. <ul style="list-style-type: none"> • For Store version 1.0: <ul style="list-style-type: none"> • 1.0 • For Store version 2.0: <ul style="list-style-type: none"> • 2.0
Multiple Manager Configuration	Primary Manager	Displays the host name of the monitoring manager specified as the primary manager for multiple monitoring. You cannot change this property.
	Secondary Manager	Displays the host name of the monitoring manager specified as the secondary manager for multiple monitoring. You cannot change this property.

Legend:

--: Not applicable

E.2 List of Agent Collector service properties

The following table lists the properties for the Agent Collector service of PFM - Agent for Microsoft SQL Server.

Table E–2: List of Agent Collector service properties of PFM - Agent for Microsoft SQL Server

Folder name	Property name	Description
--	First Registration Date	Displays the date and time on which the service was first recognized by PFM - Manager.
	Last Registration Date	Displays the date and time on which the service was last recognized by PFM - Manager.
	Data Model Version	Displays the version of the data model.
General	--	Stores information such as the host name and directories. The properties in this folder cannot be changed.
	Directory	Displays the name of the current directory where the service runs.
	Host Name	Displays the name of the physical host on which the service runs.
	Process ID	Displays the process ID of the service.
	Physical Address	Displays the IP address and port number of the host on which the service runs when IPv6 communication is disabled.
	Physical Address(IPv4)	Displays the IP address (IPv4) of the host on which the service runs when IPv6 communication is enabled.
	Physical Address(IPv6)	Displays the IP address (IPv6) of the host on which the service runs when IPv6 communication is enabled.
	Port Number	Displays the port number on which the service runs when IPv6 communication is enabled.
	User Name	Displays the name of the user who executed the service process.
Time Zone	Displays the time zone in which the service is used.	

Folder name		Property name	Description
System		--	Stores information about the OS under which the service runs. The properties in this folder cannot be changed.
		CPU Type	Displays the CPU type.
		Hardware ID	Displays the hardware ID.
		OS Type	Displays the type of OS.
		OS Name	Displays the name of the OS.
		OS Version	Displays the version of the OS.
Network Services		--	Stores information about the common library for Performance Management communication. The properties in this folder cannot be changed.
		Build Date	Displays the date on which the Agent Collector service was created.
		INI File	Displays the name of the directory containing the <code>jpcons.ini</code> file.
Network Services	Service	--	Stores information about the service. The properties in this folder cannot be changed.
		Description	Displays the host name in the following format: <i>instance-name_host-name</i>
		Local Service Name	Displays the service ID.
		Remote Service Name	Displays the service ID of the Agent Store service to which the Agent Collector service connects.
		AH Service Name	Display the service ID of the connection target Correlator service.
JP1 Event Configurations		--	Specify the condition under which JP1 event is issued.
		Each service	The user selects Yes or No from a list (Agent Collector service, Agent Store service, Action Handler service, and Status Server service) to specify whether each service issues JP1 system event.
		JP1 Event Send Host	Specify the connection target JP1/Base event server. Note that you can specify the event server on the same logical or physical host that the Action Handler service is running. The value you specify must consist of alphanumeric characters, ".", and "-", and must not exceed 255 bytes. If you exceed 255 bytes, the value you specify is discarded. If you exceed 255 bytes or do not specify this value, the host on which Action Handler service is running is used as the event issuing host. If you specify localhost , the physical host is set to this property.
		Monitoring Console Host	Specify the PFM - Web Console host, if you open a PFM - Web Console login page by using JP1/IM - Manager monitor startup function. The value you specify must consist of alphanumeric characters, ".", and "-", and must not exceed 255 bytes. If you exceed 255 bytes, the value you specify is discarded. If you exceed 255 bytes or do not specify this value, the connection target PFM - Manager host is set to this value.
		Monitoring Console Port	Specify the port number (HTTP request port number). The range of the value is from 1 to 65535. If the value you specify is out of the range, the value is discarded. If the value is out of the range or you do not specify this value, 20358 is set to this value.
		Monitoring Console Https	Specifies whether to use HTTPS-encrypted communication to access PFM - Web Console when PFM - Web Console is started by JP1/IM - Manager monitor startup. By default, this property is set to No. <ul style="list-style-type: none"> • Yes: Use encrypted communication. • No: Do not use encrypted communication.

Folder name		Property name	Description
JP1 Event Configurations	Alarm	JP1 Event Mode	Specify which type of events to issue when the alarm status changes. <ul style="list-style-type: none"> JP1 User Event: issuing JP1 user Event. JP1 System Event: issuing JP1 system event.
Detail Records		--	Stores the properties of a record of PD record type. The record ID of the collected record is shown in bold type.
Detail Records	<i>record-ID</i> ^{#1}	--	Stores the properties of a record.
		Description	Displays a description of the record. This property cannot be changed.
		Log	The user selects Yes or No from a list to specify whether to save the record to the Store database. The record is saved when this value is Yes and the value of Collection Interval is greater than zero.
		Log(ITSLM)	Displays Yes or No to indicate whether to save the records to the Store database of PFM - Agent for Microsoft SQL Server from JP1/SLM - Manager. For this property, No (fixed value) is displayed.
		Monitoring(ITSLM)	Displays Yes or No to indicate the JP1/SLM - Manager setting for whether to send records to JP1/SLM - Manager. For this property, No (fixed value) is displayed.
		Collection Interval	Specifies the data collection interval. The value is in seconds, and can be from 0 to 2,147,483,647. When zero is specified, no data is collected.
		Collection Offset	Specifies the offset value to apply before the first collection cycle. The value is in seconds, and can be from 0 to 32,767, but must be less than the value specified in Collection Interval . The time at which the collected data is recorded matches the collection interval time, regardless of the offset value.
		LOGIF	Specifies conditions for saving the record to the database. Only records that satisfy the conditions are saved. This property shows the conditional expression (character string) specified in the LOGIF Expression Editor window, which opens when the user clicks LOGIF in the bottom frame of the Properties pane in the PFM - Web Console's Services page.
		Over 10 Sec Collection Time	This property is only displayed if collection of historical data takes precedence over the display processing of real-time reports (if the functionality that prioritizes the collection of historical data is enabled). ^{#2} Whether record collection might require 10 seconds or more is indicated by Yes or No . <ul style="list-style-type: none"> Yes: Might require 10 seconds or more. No: Does not require 10 seconds. The value of this property cannot be changed.
		Realtime Report Data Collection Mode	This property is displayed only when historical data collection takes priority over real-time report display processing. (The history collection priority function is enabled.) <ul style="list-style-type: none"> Reschedule: Reschedule mode Temporary Log: Temporary log mode Note that you must specify the temporary log mode (Temporary Log) for records for which Over 10 Sec Collection Time is set to Yes.
Interval Records		--	Stores the properties of a record of PI record type. The record ID of the collected record is shown in bold type.
Interval Records	<i>record-ID</i> ^{#1}	--	Stores the properties of the record.
		Description	Displays a description of the record. This property cannot be changed.

Folder name		Property name	Description
Interval Records	<i>record-ID</i> ^{#1}	Log	The user selects Yes or No from a list to specify whether to save the record to the Store database. The record is saved when this value is Yes and the value of Collection Interval is greater than zero.
		Log(ITSLM)	Displays Yes or No to indicate whether to save the records to the Store database of PFM - Agent for Microsoft SQL Server from JP1/SLM - Manager. For this property, No (fixed value) is displayed.
		Monitoring(ITSLM)	Displays Yes or No to indicate the JP1/SLM - Manager setting for whether to send records to JP1/SLM - Manager. For this property, No (fixed value) is displayed.
		Collection Interval	Specifies the data collection interval. The value is in seconds, and can be from 0 to 2,147,483,647. When zero is specified, no data is collected.
		Collection Offset	Specifies the offset value to apply before the first collection cycle. The value is in seconds, and can be from 0 to 32,767, but must be less than the value specified in Collection Interval . The time at which the collected data is recorded matches the collection interval time, regardless of the offset value.
		LOGIF	Specifies conditions for saving the record to the database. Only records that satisfy the conditions are saved. This property shows the conditional expression (character string) specified in the LOGIF Expression Editor window, which opens when the user clicks LOGIF in the bottom frame of the Properties pane in the PFM - Web Console's Services page.
		Over 10 Sec Collection Time	This property is only displayed if collection of historical data takes precedence over the display processing of real-time reports (if the functionality that prioritizes the collection of historical data is enabled). ^{#2} Whether record collection might require 10 seconds or more is indicated by Yes or No . <ul style="list-style-type: none"> • Yes: Might require 10 seconds or more. • No: Does not require 10 seconds. The value of this property cannot be changed.
		Realtime Report Data Collection Mode	This property is displayed only when historical data collection takes priority over real-time report display processing. (The history collection priority function is enabled.) <ul style="list-style-type: none"> • Reschedule: Reschedule mode • Temporary Log: Temporary log mode Note that you must specify the temporary log mode (Temporary Log) for records for which Over 10 Sec Collection Time is set to Yes.
Log Records	--	Stores the properties of a record of PL record type. This folder is not used because PFM - Agent for Microsoft SQL Server does not use this record.	
Restart Configurations	--	Sets the condition for automatically restarting the PFM service. The condition can be set when the version of PFM - Manager or PFM - Base is 09-00 or later. For details about the PFM service Auto-restart functionality, see the chapter explaining the Performance Management functions in the JP1/Performance Management Planning and Configuration Guide.	
	Restart when Abnormal Status	Specifies whether to automatically restart a service when the Status Server service cannot obtain the status of the Action Handler service, Agent Collector service, and Agent Store service in a normal state.	
	Restart when Single Service Running	Specifies whether to automatically restart a service when only either the Agent Collector service or the Agent Store service is running.	

Folder name		Property name	Description
Restart Configurations	Action Handler	Auto Restart	Specifies whether to use automatic restart for the Action Handler service.
		Auto Restart - Interval (Minute)	Specifies the interval for checking the operating status of a service when automatic restart is used. You can specify a value from 1 through 1,440 (minutes).
		Auto Restart - Repeat Limit	Specifies the number of consecutive times restart is attempted when automatic restart is used. You can specify an integer value from 1 through 10.
		Scheduled Restart	Selects Yes or No from the list items to specify whether to use the normal restart procedure for the Action Handler service.
		Scheduled Restart - Interval	Specifies the restart interval when the normal restart procedure is used. You can specify an integer value from 1 through 1,000.
		Scheduled Restart - Interval Unit	Selects Hour , Day , Week , or Month from the list items to specify the unit for the restart interval when the normal restart procedure is used.
		Scheduled Restart - Origin - Year	Specifies the year when restart is performed. You can specify an integer value from 1971 through 2035.
		Scheduled Restart - Origin - Month	Specifies the month when restart is performed. You can specify an integer value from 1 through 12.
		Scheduled Restart - Origin - Day	Specifies the day when restart is performed. You can specify an integer value from 1 through 31.
		Scheduled Restart - Origin - Hour	Specifies the time (hour) when restart is performed. You can specify an integer value from 0 through 23.
		Scheduled Restart - Origin - Minute	Specifies the time (minute) when restart is performed. You can specify an integer value from 0 through 59.
	Agent Collector	Auto Restart	Specifies whether to use automatic restart for the Agent Collector service.
		Auto Restart - Interval (Minute)	Specifies the interval for checking the operating status of a service when automatic restart is used. You can specify a value from 1 through 1,440 (minutes).
		Auto Restart - Repeat Limit	Specifies the number of consecutive times restart is attempted when automatic restart is used. You can specify an integer value from 1 through 10.
		Scheduled Restart	Select Yes or No from the list items to specify whether to use the normal restart procedure for the Agent Collector service.
		Scheduled Restart - Interval	Specifies the restart interval when the normal restart procedure is used. You can specify an integer value from 1 through 1,000.
		Scheduled Restart - Interval Unit	Selects Hour , Day , Week , or Month from the list items to specify the unit for the restart interval when the normal restart procedure is used.
		Scheduled Restart - Origin - Year	Specifies the year when restart is performed. You can specify an integer value from 1971 through 2035.
		Scheduled Restart - Origin - Month	Specifies the month when restart is performed. You can specify an integer value from 1 through 12.
		Scheduled Restart - Origin - Hour	Specifies the time (hour) when restart is performed. You can specify an integer value from 0 through 23.

Folder name		Property name	Description
Restart Configurations	Agent Collector	Scheduled Restart - Origin - Minute	Specifies the time (minute) when restart is performed. You can specify an integer value from 0 through 59.
	Agent Store	Auto Restart	Specifies whether to use automatic restart for the Agent Store service.
		Auto Restart - Interval (Minute)	Specifies the interval for checking the operating status of a service when automatic restart is used. You can specify a value from 1 through 1,440 (minutes).
		Auto Restart - Repeat Limit	Specifies the number of consecutive times restart is attempted when automatic restart is used. You can specify a value from 1 through 10.
		Scheduled Restart	Select Yes or No from the list items to specify whether to use the normal restart procedure for the Agent Store service.
		Scheduled Restart - Interval	Specifies the restart interval when the normal restart procedure is used. You can specify an integer value from 1 through 1000.
		Scheduled Restart - Interval Unit	Selects Hour , Day , Week , or Month from the list items to specify the unit for the restart interval when the normal restart procedure is used.
		Scheduled Restart - Origin - Year	Specifies the year when restart is performed. You can specify an integer value from 1971 through 2035.
		Scheduled Restart - Origin - Month	Specifies the month when restart is performed. You can specify an integer value from 1 through 12.
		Scheduled Restart - Origin - Day	Specifies the day when restart is performed. You can specify an integer value from 1 through 31.
		Scheduled Restart - Origin - Hour	Specifies the time (hour) when restart is performed. You can specify an integer value from 0 through 23.
		Scheduled Restart - Origin - Minute	Specifies the time (minute) when restart is performed. You can specify an integer value from 0 through 59.
		ITSLM Connection Configuration	
ITSLM Connection Configuration	ITSLM Connection	--	Displays information about the connection-target JP1/SLM - Manager.
		ITSLM Host	Displays the host name of the connected JP1/SLM - Manager. If a connection with JP1/SLM - Manager has not been established, this property is not displayed.
		ITSLM Port	Displays the port number of the connected JP1/SLM - Manager. If a connection with JP1/SLM - Manager has not been established, this property is not displayed.
	MANAGE ITSLM CONNECTION	--	Specifies whether to end the connection with JP1/SLM - Manager.
		DISCONNECT ITSLM CONNECTION	Selects from the list items the JP1/SLM - Manager host name that is to be disconnected. If (empty string) is selected from the list items, nothing is done. If a connection with JP1/SLM - Manager has not been established, only (empty string) is displayed in the list items.
Multiple Manager Configuration		Primary Manager	Displays the host name of the monitoring manager specified as the primary manager for multiple monitoring. You cannot change this property.
		Secondary Manager	Displays the host name of the monitoring manager specified as the secondary manager for multiple monitoring. You cannot change this property.
Agent Configuration		--	Stores the properties for settings specific to PFM - Agent for Microsoft SQL Server.
		Product	Displays the product ID, Q.

Folder name	Property name	Description
Agent Configuration	Instance	Displays the instance name of the monitored Microsoft SQL Server, which was specified by using the <code>jpconf inst setup</code> command (If the default settings are used for the instance environment, default is displayed).
	SQL_Host	Displays the name of the host on which the monitored Microsoft SQL Server is running.
	User	Displays the user name that is used to log in to the monitored Microsoft SQL Server (The user name is encrypted when it is stored in the <code>jpconf.ini</code> file). When Windows authentication is used, the user name will not be displayed.
	Errorlog	Displays the name of the error log file of the monitored Microsoft SQL Server instance, which was specified by using the <code>jpconf inst setup</code> command. The file name is displayed in a full path format.
	Timeout	Displays the timeout value (in seconds) for queries to the database, which was specified by using the <code>jpconf inst setup</code> command. The default value is 60. To change this property, specify from 1 to 3600. This property can be changed. ^{#2}
	STARTUP_PENDING	Displays the pending time (in seconds), from when PFM - Agent for Microsoft SQL Server had started until it transferred to normal operation, which was specified by using the <code>jpconf inst setup</code> command. The default value is 0. Pending is not performed when 0 is specified. To change this property, specify from 1 to 3600. This property can be changed. ^{#2}
	LOG_PATH	Displays the output folder for agent log files, which was specified by using the <code>jpconf inst setup</code> command. This property can be changed. ^{#2}
	LOG_SIZE	Displays the maximum size (in MB) of an agent log file, which was specified by using the <code>jpconf inst setup</code> command. The default value is 16. To change this property, specify from 1 to 32. This property can be changed. ^{#2}
	LOGIN_TIMEOUT	Displays the timeout value (in seconds) for connecting to the database, which was specified by using the <code>jpconf inst setup</code> command. The default value is 20. To change this property, specify from 1 to 3600. This property can be changed. ^{#2}
	TOPN_SQL	This property is used for a reserved record, and cannot be changed.
	DISK_READS_PER_EXECUTION	This property is used for a reserved record, and cannot be changed.
	DB_FREE_PERC_OPTION	Specifies the operation to be performed if the value of the Free % field of the Database Space Detail (PD_DS) record is negative. This property can be changed. ^{#2}
	DB_FREE_PERC_NUMBER	Specifies a value to replace with the value of the Free% field of the Database Space Detail (PD_DS) record if the value is negative. This property is valid if Y is specified for the DB_FREE_PERC_OPTION property. This property can be changed. ^{#2}
	LIMIT_PD_LD_NUMBER	Displays the maximum number of Lock Detail (PD_LD) records that can be collected. The default value is 1000. To change this property, specify from 0 to 900000. This property can be changed. ^{#2}
LIMIT_PD_EE_NUMBER	Displays the maximum number of Errorlog Error Detail (PD_EE) records that can be collected. This property is valid if you collect histories or monitor operations by using alarms. The default value is	

Folder name	Property name	Description
Agent Configuration	LIMIT_PD_EE_NUM BER	1000. To change this property, specify from 100 to 100000. This property can be changed.#2

Legend:

--: Not applicable.

#1

The folder name is shown as the record ID excluding the database ID. For details about the record ID of each type of record, see [5. Records](#).

#2

To reflect updated values, restart the Agent Collector service.

F. List of Files and Folders

This appendix lists the files and folders of PFM - Agent for Microsoft SQL Server.

Performance Management can be installed in any folder. The default installation folder is:

- *system-drive*\Program Files(x86)\Hitachi\jplpc\

F.1 PFM - Agent for Microsoft SQL Server files and directories

The following table lists the files and folders of PFM - Agent for Microsoft SQL Server.

Table F–1: List of files and folders for PFM - Agent for Microsoft SQL Server

Folder name	File name	Description
<i>installation-folder</i> \agtq\	--	Base folder of PFM - Agent for Microsoft SQL Server
	jpcagtras.bat	Maintenance information collection program
	jpcagtras.exe	Maintenance information collection program
	Readme_ja.txt	README file (Japanese)
	Readme_en.txt	README file (English)
	VERSION.TXT	VERSION.TXT
	multilingual.dat	Maintenance data file
<i>installation-folder</i> \agtq\agent\	--	Base folder of the Agent Collector service
	jpcagtq.exe	Service executing program of Agent Collector
<i>installation-folder</i> \agtq\agent\ <i>instance-name</i> \	--	Base folder of Agent Collector service (for each instance) ^{#1}
	COSLMMI.DB	Data file for the JP1/SLM linkage setting
	COSLMMI.IDX	Index file for the data file for the JP1/SLM linkage setting
	COSLMMI.LCK	Lock file for the data file for the JP1/SLM linkage setting
	jpcagt.ini	Service startup initialization file of Agent Collector (for each instance) ^{#1}
	jpcagt.ini.model	Model file for the service startup initialization file of Agent Collector service (for each instance) ^{#1}
<i>installation-folder</i> \agtq\agent\ <i>instance-name</i> \log\	--	Storage folder for internal log file of the Agent Collector service (for each instance) ^{#1}
<i>installation-folder</i> \agtq\lib\	--	Message catalog installation folder
<i>installation-folder</i> \agtq\sql	--	SQL script storage folder
	sp_drop.sql	SQL script file for deleting an Microsoft SQL Server Database object

Folder name	File name	Description
<i>installation-folder</i> \agtq\sql	sp_inst.sql	SQL script file for registering an Microsoft SQL Server Database object
<i>installation-folder</i> \agtq\store\	--	Base folder of Agent Store service
	*.DAT	Data model definition file
<i>installation-folder</i> \agtq\store\ <i>instance-name</i> \	--	Base folder of Agent Store service (for each instance) ^{#1}
	*.DB	Performance data file (for each instance) ^{#2}
	*.IDX	Performance data index file (for each instance) ^{#2}
	*.LCK	Performance data lock file (for each instance) ^{#2}
	jpcsto.ini	Agent Store (for each instance) ^{#1}
	jpcsto.ini.model	Model file for the service startup initialization file of Agent Store (for each instance) ^{#1}
	*.DAT	Data model definition file (for each instance) ^{#1}
<i>installation-folder</i> \agtq\store\ <i>instance-name</i> \backup\	--	Default database backup destination folder (for each instance) ^{#1}
<i>installation-folder</i> \agtq\store\ <i>instance-name</i> \dump\	--	Default database export destination folder (for each instance) ^{#1}
<i>installation-folder</i> \agtq\store\ <i>instance-name</i> \log\	--	Storage folder for internal log file of Agent Store service (for each instance) ^{#1}
<i>installation-folder</i> \auditlog\	--	Action log file output folder
	jpcaudit <i>n</i> .log# 3	Action log file
<i>installation-folder</i> \patch_files\agtq\	--	Folder for storing patch files (for agents)
<i>installation-folder</i> \setup\	--	Setup file storage folder
	jpcagtqu.Z	Archive file for PFM - Agent for Microsoft SQL Server setup (UNIX)
	jpcagtw.EXE	Archive file for PFM - Agent for Microsoft SQL Server setup (Windows)
<i>system-folder</i> \system32	--	System folder
	mfc100.dll	Microsoft Visual C++ MFC runtime file
	mfc100u.dll	Microsoft Visual C++ MFC runtime file
	mfc100.dll	Microsoft Visual C++ MFC runtime file
	mfc100u.dll	Microsoft Visual C++ MFC runtime file
	mfc100chs.dll	Microsoft Visual C++ MFCLOC resource file
	mfc100cht.dll	Microsoft Visual C++ MFCLOC resource file

Folder name	File name	Description
<i>system-folder</i> \system32	mfc100deu.dll	Microsoft Visual C++ MFCLOC resource file
	mfc100enu.dll	Microsoft Visual C++ MFCLOC resource file
	mfc100esn.dll	Microsoft Visual C++ MFCLOC resource file
	mfc100fra.dll	Microsoft Visual C++ MFCLOC resource file
	mfc100ita.dll	Microsoft Visual C++ MFCLOC resource file
	mfc100jpn.dll	Microsoft Visual C++ MFCLOC resource file
	mfc100kor.dll	Microsoft Visual C++ MFCLOC resource file
	mfc100rus.dll	Microsoft Visual C++ MFCLOC resource file

Legend:

--: Not applicable

#1

Created by execution of the `jpccconf inst setup` command.

#2

Created when the Agent Store service is started.

#3

n is numeric value. The number of log files can be changed in the `jpccomm.ini` file.

G. Migration Procedure and Notes on Migration

To upgrade PFM - Agent for Microsoft SQL Server, you need to perform overwrite installation on PFM - Agent for Microsoft SQL Server. For details about the installation procedure, see [2. Installation and Setup](#).

For details about notes on upgrading the versions of Performance Management programs, see the section describing the notes on version upgrading in the chapter and appendix that explain installation and setup in the *JPI/Performance Management Planning and Configuration Guide*.

This appendix shows the notes on upgrading the version of PFM - Agent for Microsoft SQL Server.

- Do not uninstall the old version of PFM - Agent for Microsoft SQL Server during upgrading. If you uninstall it, performance data created in the old version is deleted and will no longer be available in the new version.
- When you perform overwrite installation on a PFM - Agent for Microsoft SQL Server program, the following information is updated automatically:
 - Store database files of Agent Store service
 - `ini` file
 - Instance environment of PFM - Agent for Microsoft SQL Server
- In Performance Management programs of version 08-00 or newer, the locations of the Store executing programs (`jpcto.exe` and `stpqlpr.exe`) have been changed. When PFM - Manager and PFM - Agent are upgraded to version 08-00 or newer, the Store executing programs at the older locations are deleted.
- In a logical host environment, when port numbers for Microsoft SQL Server are set to other than standard, in version 11-10 or earlier you need to specify a 32-bit alias by using SQL Server Client Network Utility on the PFM - Agent host or any other tool, but in version 11-50 or later you need to specify a 64-bit alias.

If the *alias* settings are incorrect, the KAVF21810-E message is output to the agent log error file and connection to Microsoft SQL Server will fail.

For details about alias settings, see 3.3.2(5) Notes when a non-default Microsoft SQL Server port number.

Note that you do not need to specify a 32-bit *alias*. If the 32-bit *alias* is not used except PFM - Agent for Microsoft SQL Server, there are no problems even if you delete it.

- If you upgrade version 11-10 or earlier to version 11-50 or later, object permissions required to monitor Microsoft SQL Server are added. If you specify object permissions for user accounts that are used for monitoring, add object permissions shown in the following table. For details about required object permissions, see 2.1.4(2)(c) Login permissions of the Microsoft SQL Server.

Table G–1: Object permissions added in 11-50 or later

Records	Object permissions granted to users required for collecting records	
	If SQL Server version 2014 or earlier	If SQL Server version 2016 or later
PD_DD, PI_DI	Grant the SELECT permission for the following objects in the master database: <ul style="list-style-type: none"> • <code>sysperfinfo</code> 	Grant the SELECT permission for the following objects in the master database: <ul style="list-style-type: none"> • <code>sys.dm_os_performance_counters</code>

If the permissions are not sufficient, the following message is output to the agent log error file.

- If SQL Server version 2014 or earlier
KAVF21812-E SQL Server (ADO) returned an error.
(`rc = 0x80040e09, msg = SELECT permission was denied on the object 'sysperfinfo', database 'mssqlsystemresource', schema '<the-user-account-used-for-monitoring>'.`)
- If SQL Server version 2016 or later

KAVF21812-E SQL Server (ODBC) returned an error.

(rc = 42000, msg = [Microsoft][ODBC SQL Server Driver][SQL Server]SELECT permission was denied on the object 'dm_os_performance_counters', database, 'mssqlsystemresource', schema '<the-user-account-used-for-monitoring>'.)

H. Version Compatibility

For PFM - Agent for Microsoft SQL Server, there are different data model versions as well as products.

The data model version remains unchanged. Because data models are upward-compatible, the report and alarm definitions created by an older version are available in a newer data model version.

The table below shows the correspondence between the versions of PFM - Agent for Microsoft SQL Server.

Table H–1: Correspondence between PFM - Agent for Microsoft SQL Server versions

PFM - Agent for Microsoft SQL Server version	Data model version	Version of the monitoring template alarm table
06-70	3.0	6.70
07-00	3.0	7.00
07-50	3.0	7.50
08-00	4.0	8.00
08-10	5.0	8.10
08-50	5.0	8.50
09-00	6.0	09.00
10-00	6.0	09.00
11-00	6.0	09.00
11-10	7.0	11.10
11-50	8.0	11.50

For details about version compatibility, see the information in the appendixes of the manual *JP1/Performance Management Planning and Configuration Guide*.

I. Deleting the A4QHITACHIPROCSPDATABASES Stored Procedure

This appendix describes how to delete the A4QHITACHIPROCSPDATABASES stored procedure.

The A4QHITACHIPROCSPDATABASES stored procedure is required to acquire a list of database names and sizes from Microsoft SQL Server when the monitored Microsoft SQL Server instance includes a database that is 2 TB or larger.

For details about how to register the A4QHITACHIPROCSPDATABASES stored procedure, see [2.1.4\(3\) Registering the A4QHITACHIPROCSPDATABASES Stored Procedure](#).

I.1 Procedure for deleting A4QHITACHIPROCSPDATABASES

You can delete the A4QHITACHIPROCSPDATABASES stored procedure by using the `sp_drop.sql` script provided by PFM - Agent for Microsoft SQL Server.

To delete A4QHITACHIPROCSPDATABASES:

1. Set up an environment in which the `sqlcmd` utility of Microsoft SQL Server can be executed.

The `sqlcmd` utility is provided by Microsoft. For details about the environment settings for Microsoft SQL Server, see your Microsoft SQL Server documentation.

2. Move to the folder in which the `sp_drop.sql` script is located.

The script is located in the following folder:

```
installation-folder\agtq\agent\sql
```

3. Execute the script with the monitored Microsoft SQL Server instance specified.

The command line for executing the `sp_drop.sql` script depends on the type of the monitored Microsoft SQL Server instance and the method of authentication used for connecting to Microsoft SQL Server. The following shows the command line for each condition.

- When the default instance of Microsoft SQL Server is being monitored

Authentication	Command line for executing the <code>sp_drop.sql</code> script
SQL Server	<code>sqlcmd -S host-name -U user-name -P password -d master -i sp_drop.sql #</code>
Windows	<code>sqlcmd -S host-name -E -d master -i sp_drop.sql #</code>

- When a named instance of Microsoft SQL Server is being monitored

Authentication	Command line for executing the <code>sp_drop.sql</code> script
SQL Server	<code>sqlcmd -S host-name\instance-name -U user-name -P password -d master -i sp_drop.sql #</code>
Windows	<code>sqlcmd -S host-name\instance-name -E -d master -i sp_drop.sql #</code>

#

The following describes the items that the user specifies:

host-name: Name of the host on which the monitored Microsoft SQL Server instance operates

instance-name: Name of the monitored Microsoft SQL Server instance

user-name: `sa` or a user account having the permissions equivalent to `sa` (account of a member of the `sysadmin` fixed server role)

password: Password for the specified user name

J. Outputting Action Log Information

Action log information of Performance Management is output in conjunction with the alarm function related to an exceeded threshold for information, such as system load.

For example, when PFM services start or stops or when the connection status with PFM - Manager changes, action logs are output.

Action logs are output if the version of PFM - Manager or PFM - Base is 08-10 or later.

An action log is a CSV text file. By saving action logs periodically and converting them with spreadsheet software, you can use the action logs as analysis data.

Output of action logs is specified in the `jpccomm.ini` file. This appendix describes the contents of the action log output by PFM - Agent and PFM - Base, and how to specify the setting for outputting the action log.

J.1 Event types output to the action log

The following table shows the event types output to the action log and the times at which PFM - Agent for Microsoft SQL Server and PFM - Base output information to the action log. The event types are the identifiers used within the action log to classify the events output to the action log.

Table J–1: Event types output to the action log

Event type	Explanation	PFM - Agent for Microsoft SQL Server and PFM - Base output the action log when:
ExternalService	Events indicating the result of communication between a JP1 product and an external service. This event type also indicates that an abnormal communication has occurred.	The status of a connection with PFM - Manager has changed.
ManagementAction	Events indicating that an important program action has been executed. This event type also indicates that the action was executed in response to another audit category.	An automated action is executed.

J.2 Format for saving the action log files

This section explains the format for saving the action log files.

Action log information is output to a specified file (current output file). When the current output file becomes full, the action log information in that file is saved to another file (shift file). The procedure for switching the file for storing action log information is as follows:

1. Action log information is output sequentially to the current output file `jpcaudit.log`.
2. When the current output file becomes full, the action log information is saved in a shift file. The name of a shift file is the current output file name suffixed with a number. Each time the current output file becomes full, each shift file is renamed by incrementing the suffix by 1. Therefore, the file whose name has the largest number is the oldest log file.

Example:

When the current output file `jpcaudit.log` becomes full, the contents of the file are saved to the shift file `jpcaudit1.log`.

When the current output file becomes full again, the information is moved to `jpcaudit1.log`, and the existing shift file `jpcaudit1.log` is renamed to `jpcaudit2.log`.

Note that when the number of log files exceeds the number of saved log files (specified in the `jpccomm.ini` file), the oldest log file is deleted.

3. The current output file is initialized, and new action log information is written.

Whether action log information is to be output, the output destination, and the number of output files are specified in the `jpccomm.ini` file. For details about how to specify the `jpccomm.ini` file, see [J.4 Settings for outputting action logs](#).

J.3 Action log output format

Information related to audit events is output to the Performance Management action log. One action log information file is output for one host (physical host and logical host). The action log file is output to either of the following hosts:

- When a service is executed: The file is output to the host on which the service runs.
- When a command is executed: The file is output to the host on which the command was executed.

The following describes the format of the action log, the output destination, and the items that are output.

(1) Output format

```
CALFHM x.x, output-item-1=value-1, output-item-2=value-2, ..., output-item-  
n=value-n
```

(2) Output destination

On physical hosts

```
installation-folder\auditlog\
```

On logical hosts

```
environment-folder\jplpc\auditlog\
```

The action log output destination can be changed in the `jpccomm.ini` file. For details about how to specify the `jpccomm.ini` file, see [J.4 Settings for outputting action logs](#).

(3) Output items

There are two types of output items:

- Common output item
An item that is always output by all JP1 products that output action logs
- Fixed output item
An item that is optionally output by a JP1 product that outputs action logs

(a) Common output items

The following table lists and describes the common output items and their values. This table also includes the items and information output by PFM - Manager.

Table J–2: Common output items in action logs

No.	Output item		Value	Explanation
	Item name	Output attribute name		
1	Common specification identifier	--	CALFHM	Indicates the action log format.
2	Common specification revision number	--	x.x	Revision number for managing action logs
3	Serial number	seqnum	<i>serial-number</i>	Serial number of the action log record
4	Message ID	msgid	KAVE xxxxx-x	Message ID of the product
5	Date and time	date	YYYY-MM-DDThh:mm:ss.sssTZD#	Date, time, and time zone indication identifying when the action log was output
6	Program name	progid	JP1PFM	Name of the program for which the event occurred
7	Component name	compid	<i>service-ID</i>	Name of the component for which the event occurred
8	Process ID	pid	<i>process-ID</i>	Process ID of the process for which the event occurred
9	Location	ocp:host	<ul style="list-style-type: none"> <i>host-name</i> <i>IP-address</i> 	Location where the event occurred
10	Event type	ctgry	<ul style="list-style-type: none"> StartStop Authentication ConfigurationAccess ExternalService AnomalyEvent ManagementAction 	Category name used to classify the event output to the action log
11	Event result	result	<ul style="list-style-type: none"> Success Failure Occurrence 	Result of the event
12	Subject identification information	subj:pid	<i>process-ID</i>	One of the following: <ul style="list-style-type: none"> Process ID of a process running as a user operation Process ID of the process that caused the event Name of the user who caused the event Identification information in a one-to-one correspondence with the user
		subj:uid	<i>account-identifier</i> (PFM user/JP1 user)	
		subj:euid	<i>effective-user-ID</i> (OS user)	

Legend:

--: None

#

T is a separator between the date and the time.

TZD is the time zone specifier. One of the following values is output.

+*hh:mm*: The time zone is *hh:mm* ahead of UTC.

-*hh:mm*: The time zone is *hh:mm* behind UTC.

z: The time zone is same as UTC.

(b) Fixed output items

The following table lists and describes the fixed output items and their values. This table also includes the items and information output by PFM - Manager.

Table J–3: Fixed output items in action logs

No.	Output item		Value	Explanation
	Item name	Output attribute name		
1	Object information	obj	<ul style="list-style-type: none"> • <i>PFM - Agent-service-ID</i> • <i>added-deleted-or-updated-user-name</i> (PFM user) 	Intended object for the operation
		obj:table	<i>alarm-table-name</i>	
		obj:alarm	<i>alarm-name</i>	
2	Action information	op	<ul style="list-style-type: none"> • Start • Stop • Add • Update • Delete • Change Password • Activate • Inactivate • Bind • Unbind 	Information about the action that caused the event
3	Permissions information	auth	<ul style="list-style-type: none"> • Administrator • Management • General user Ordinary • Windows Administrator • UNIX SuperUser 	Permissions information of the user who executed the command or service
		auth:mode	<ul style="list-style-type: none"> • PFM authentication mode pfm • JP1 authentication mode jp1 • OS user os 	Authentication mode of the user who executed the command or service
4	Output source	outp:host	<i>PFM - Manager-host-name</i>	Host that output the action log

No.	Output item		Value	Explanation
	Item name	Output attribute name		
5	Instruction source	subjp:host	<ul style="list-style-type: none"> • <i>login-host-name</i> • <i>execution-host-name</i> (only when the <code>jpctool alarm</code> command is executed) 	Host that issued the instruction for the operation
6	Free description	msg	<i>message</i>	Message that is output when an alarm occurs or when an automated action is executed

Whether the fixed output items are output and what they contain differ depending on when the action log is output. The following describes the message ID and output information for each case.

■ A PFM service is started or stopped (StartStop)

- Output host: The host on which the service is running
- Output component: The service that was started or stopped

Item name	Attribute name	Value
Message ID	msgid	Started: KAVE03000-I Stopped: KAVE03001-I
Action information	op	Started: Start Stopped: Stop

■ Stand-alone mode is started or terminated (StartStop)

- Output host: PFM - Agent host
- Output component: Agent Collector service and Agent Store service

Item name	Attribute name	Value
Message ID	msgid	Stand-alone mode has started: KAVE03002-I Stand-alone mode has terminated: KAVE03003-I

#1

No fixed output items are output.

#2

When PFM - Agent for Microsoft SQL Server is started, PFM - Agent for Microsoft SQL Server services connect to the PFM - Manager host, register node information, and obtain the latest alarm definition information. If a connection with the PFM - Manager host cannot be established, PFM - Agent for Microsoft SQL Server starts in stand-alone mode, in which only part of its functionality, such as collection of operating information, is enabled. In addition, `KAVE03002-I` is output to indicate that PFM - Agent for Microsoft SQL Server has started in stand-alone mode. From this point, the PFM - Agent for Microsoft SQL Server services periodically attempt to connect to PFM - Manager. When the services are able to successfully register node information or obtain definition information, PFM - Agent for Microsoft SQL Server leaves stand-alone mode and `KAVE03003-I` is output. In this way, the action log enables you to understand that PFM - Agent for Microsoft SQL Server was running in an imperfect condition for the period from the output of `KAVE03002-I` to the output of `KAVE03003-I`.

■ The status of the connection with PFM - Manager changes (ExternalService)

- Output host: PFM - Agent host
- Output component: Agent Collector service and Agent Store service

Item name	Attribute name	Value
Message ID	msgid	Sending of an event to PFM - Manager failed (queuing was started): KAVE03300-I

Item name	Attribute name	Value
Message ID	msgid	An event was resent to PFM - Manager: KAVE03301-I Stand-alone mode has started: KAVE03302-I Restore from stand-alone: KAVE03303-I

#1

No fixed output items are output.

#2

When sending of an event to PFM - Manager fails, Agent Store service starts queuing events. The maximum capacity of the queue is 3 events. KAVE03300-I is output when sending of an event to PFM - Manager fails and queuing starts. After the connection with PFM - Manager restores and the queued events are resent, KAVE03301-I is output. From this sequence of the log, you can judge that the period when an event-sending to PFM - Manager is not real time is specifiable.

#3

The Agent Collector service normally sends events to PFM - Manager via the Agent Store service. The Agent Collector service directly sends events to PFM - Manager only when the Agent Store service stops for any reason. If the Agent Collector service fails to send events directly to PFM - Manager, KAVE03300-I is output. In this case, KAVE03301-I is no output because the queuing does not start. From this sequence of the log, you can judge that there are events that are not sent to PFM - Manager.

■ An automated action is executed (ManagementAction)

- Output host: The host on which the action was executed
- Output component: Action Handler service

Item name	Attribute name	Value
Message ID	msgid	The command execution process was created successfully: KAVE03500-I. An attempt to create a command execution process failed: KAVE03501-W. E-mail was send successfully: KAVE03502-I. Sending of e-mail failed: KAVE03503-W
Free description	msg	Command execution: cmd= <i>executed-command-line</i> . E-mail sending: mailto= <i>destination-email-address</i> .

Note:

KAVE03500-I is output when the command execution process is successfully created. After KAVE03500-I is output, whether the command is successfully executed or not and the execution result are not output to the action log.

(4) Output example

The following is an example of action log output.

```
CALFHM 1.0, seqnum=1, msgid=KAVE03000-I, date=2007-01-18T22:46:49.682+09:00,
progid=JP1PFM, compid=QA1host01, pid=2076,
ocp:host=host01, ctgry=StartStop, result=Occurrence,
subj:pid=2076,op=Start,
```

J.4 Settings for outputting action logs

The settings for outputting action logs are defined in the `jpccomm.ini` file. If no settings are specified, no action logs are output. The following describes the settings required to output the action logs, and how to specify the settings.

(1) Setting procedure

To specify the settings for outputting action log information:

1. Stop all PFM services on the host.
2. Using a text editor, edit the `jpccomm.ini` file.
3. Save and close the `jpccomm.ini` file.

(2) Details about the `jpccomm.ini` file

The following describes the `jpccomm.ini` file in detail.

(a) Storage folder

installation-folder

(b) Format

In the `jpccomm.ini` file, define the following information:

- Whether or not to output action log information
- Output destination of the action log
- Number of action logs that can be saved
- File size of the action log

The specification format is as follows:

"item-name"=value

The following table shows the items that you specify.

Table J–4: Items specified in the `jpccomm.ini` file and their initial values

No.	Item	Explanation
1	[Action Log Section]	The section name, which cannot be changed.
2	Action Log Mode	Specify whether or not to output action log information. You must specify this item. <ul style="list-style-type: none">• Initial value 0 (Information not output)• Specifiable value 0 (Information not output) or 1 (Information output) If any other value is specified, an error message is output and action log information will not be output.
3	Action Log Dir#	Specify the action log output destination. In a logical host environment, specify a directory on the shared disk. If the directory you specify is not on the shared disk, Performance Management will output action logs to each physical host that forms the basis for the logical host. If a path longer than the limit is specified or if access to the directory fails, an error message is output to the command log and action log information will not be output. <ul style="list-style-type: none">• Initial value None set• Default value used when no specification is made On physical hosts:

No.	Item	Explanation
3	Action Log Dir#	<p><i>installation-folder</i>\auditlog\ On logical hosts: <i>environment-folder</i>\jplpc\auditlog\ • Specifiable value A character string of 1 to 185 bytes</p>
4	Action Log Num	<p>Specify the upper limit on the total number of log files (number of saved files). Specify the sum of the number of current output file and shift files.</p> <ul style="list-style-type: none"> • Initial value • None set • Default value used when no specification is made: • 5 • Specifiable value <p>An integer in the range from 2 to 10</p> <p>If a character string containing a non-numeric value is specified, an error message is output and the default value 5 is set. If a numeric value outside the valid range is specified, an error message is output and an integer nearest the specified value in the range from 2 to 10 is set.</p>
5	Action Log Size	<p>Specify the log file size in kilobytes.</p> <ul style="list-style-type: none"> • Initial value • None set • Default value used when no specification is made: • 2048 • Specifiable value <p>An integer in the range from 512 to 2096128</p> <p>If a character string containing a non-numeric value is specified, an error message is output and the default value 2048 is set. If a numeric value outside the valid range is specified, an error message is output and an integer nearest the specified value in the range from 512 to 2096128 is set.</p>

#

When you use the `jpcconf ha setup` command to set up a logical host after you configure action log output on the physical host, the settings in the `jpccomm.ini` file of the physical host apply to the logical host. When using Performance Management on a logical host and a physical host at the same time, make sure that both hosts do not output action logs to the same directory.

K. Linking with JP1/SLM

The capability of PFM - Agent for Microsoft SQL Server to monitor operating status can be enhanced through linkage with JP1/SLM.

PFM - Agent for Microsoft SQL Server provides default monitoring items specific to JP1/SLM for PFM - Manager to enable monitoring on JP1/SLM.

The default monitoring items provided by PFM - Agent for Microsoft SQL Server for PFM - Manager are described in the following table.

In addition, PFM - Agent for Microsoft SQL Server collects records corresponding to the value specified as the key for multi-instance records. For the corresponding collection key, see the collection result for each record.

Table K–1: Default monitoring items provided by PFM - Agent for Microsoft SQL Server for PFM - Manager

Display name in JP1/SLM	Description	Record (Record ID)	Key (PFM-Manager name)	Field name
Cache Hit rate	Monitors the ratio of requests found in the data cache to disk read operations	Server Overview (PI_SERV)	--	CACHE_HIT_RATIO
CPU usage rate	Monitors the ratio of CPU consumption by the current session.	Global Server Summary (PI)	--	PERC_BUSY
Database free space rate	Monitors the percentage of free space in each database.	Database Space Detail (PD_DS)	DB_NAME, DBID	PERC_FREE
Log space usage rate	Monitors the percentage of transaction log space that is being used by the transaction log	Transaction Log Overview (PI_TLOG)	DB_NAME	LOG_SPACE_USED_PCT

To provide the default monitoring items for PFM - Manager, you need to copy the setup file and execute the setup command. For details, see [2.1.4\(1\) Registering PFM - Agent for Microsoft SQL Server](#).

L. About Communication in IPv4 Environments and IPv6 Environments



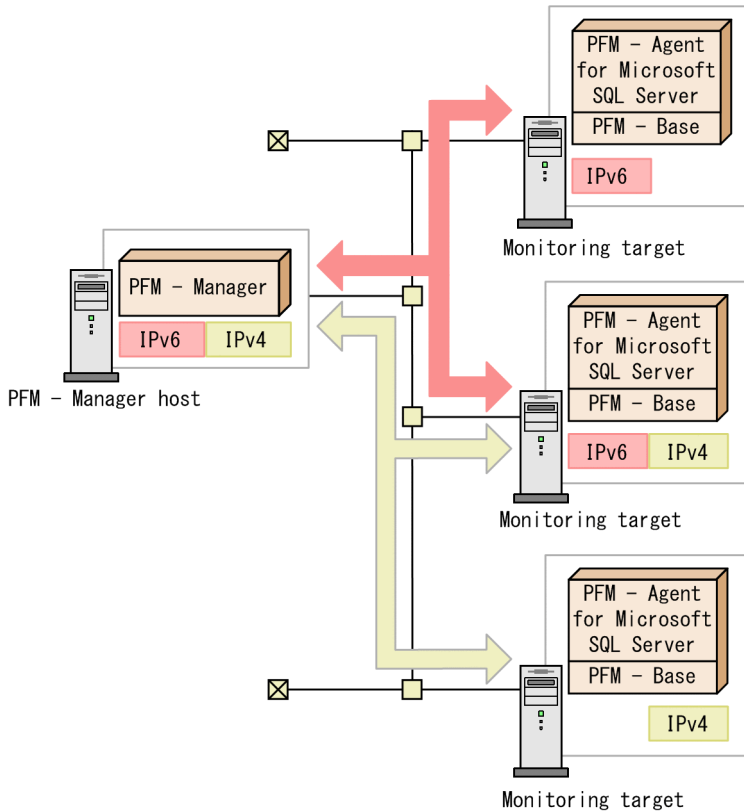

Performance Management supports IPv6 environments in addition to IPv4 environments as a network configuration. Therefore, Performance Management can operate even in a network configuration in which both an IPv4 environment and IPv6 environment are used.

Note that this explanation applies only when the OS of a host on which PFM - Agent for Microsoft SQL Server is installed is Windows, and the OS of a host on which PFM - Manager is installed is Windows or Linux.

Figure L-1: Scope of communication when an IPv4 environment and an IPv6 environment are used

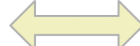

Legend:

-  : Indicates a program provided by Performance Management
-  : IPv4 environment
-  : IPv6 environment
-  : IPv4 communication
-  : IPv6 communication

To enable communication in an IPv6 environment, you must execute the `jpccconf ipv6 enable` command. For details about the `jpccconf ipv6 enable` command, see the chapter that describes commands in the manual *JPI/Performance Management Reference*. For the conditions and timing for executing the `jpccconf ipv6 enable` command, see the chapter that describes network configuring examples in an IPv6 environment in the *JPI/Performance Management Planning and Configuration Guide*.

M. Version Revisions

This appendix shows the changes that have been made to each version of the manual.

M.1 Revisions in 11-50

- For the following record, the required permissions for each object which PFM - Agent for Microsoft SQL Server uses when collecting records were added:
 - Database Detail
 - Database Interval
- Notes indicating that when a non-default Microsoft SQL Server port number is used to connect with Microsoft SQL Server, a 64-bit *alias* is required were added.
- The version of the data model has been changed from 7.0 to 8.0, and the version of the alarm table has been changed from 11.10 to 11.50.
- With the change of data model, the versions of the following reports that use fields for which the type of their data model was changed in version 8.0 or that refer to such reports were changed:
 - Blocked Sessions
 - Blocking Locks
 - Cache Usage
 - Cache Usage Trend(Multi-Agent)
 - CPU Usage - Top 10 Sessions
 - Database Detail
 - Database Summary
 - Lock Detail
 - Lock Overview
 - Lock Usage - Top 10 Sessions
 - Log I/O Activity
 - Log I/O Activity 2
 - Memory Usage - Top 10 Sessions
 - Pending I/O
 - Physical I/O - Top 10 Sessions
 - Physical Write Activity
 - Physical Write Activity 2
 - Session Detail
 - Sessions
 - System Overview
- The sizes of the following records were changed:
 - Database Detail (PD_DD)
 - Database Interval (PI_DI)

- Server Overview (PI_SERV)
- Server Overview 2 (PI_SRV2)
- Fields were added to the following records:
 - Database Detail (PD_DD)
 - Database Interval (PI_DI)
 - Server Overview (PI_SERV)
 - Server Overview 2 (PI_SRV2)
- The following messages have been changed:
 - KAVF21810-E
- The folder name of Redistributable Files of PFM - Agent for Microsoft SQL Server was changed.
- Notes on migration were added.

M.2 Revisions in 11-10

- The following OSs are now supported:
 - Microsoft(R) Windows Server(R) 2016 Datacenter
 - Microsoft(R) Windows Server(R) 2016 Standard
- The following has been added as databases that can be monitored.
 - Microsoft SQL Server 2016
- The required permissions for collecting the performance information of Microsoft SQL Server Database were added for each version of the database.
- The version of the data model has been changed from 6.0 to 7.0, and the version of the alarm table has been changed from 09.00 to 11.10.
- The version of the data model (7.0) was added to the related reports of the alarm:
 - Blocked Sessions
 - Cache Usage
 - CPU Usage
 - Database Space
 - Server Status
- The version (7.0) was added to the following reports that use fields for which the type of their data model was changed in version 7.0 due to the change in the data models, or that refer to such reports:
 - Blocked Sessions
 - Blocking Locks
 - Cache Usage
 - CPU Usage - Top 10 Sessions
 - Database Detail
 - Database Space Usage
 - Database Space Usage Detail
 - Database Summary

- Lock Detail
- Lock Overview
- Lock Usage - Top 10 Sessions
- Memory Usage - Top 10 Sessions
- Physical I/O - Top 10 Sessions
- Server Space Usage
- Session Detail
- Sessions
- System Overview
- The fields in the following reports now have a separate description for SQL Server 2014 or earlier and SQL Server 2016 or later:
 - Database Detail
 - Database Summary
 - Memory Usage - Top 10 Sessions
 - Session Detail
 - Sessions
- The sizes of the following records were changed:
 - Database Detail (PD_DD)
 - Database Interval (PI_DI)
 - Database Replication Detail (PD_RD)
 - Database Space Detail (PD_DS)
 - Job History Detail (PD_JH)
 - Lock Detail (PD_LD)
 - Process Detail (PD_PDET)
- The fields of the following records now have a separate description and data source for SQL Server 2014 or earlier and SQL Server 2016 or later:
 - Database Detail (PD_DD)
 - Database Interval (PI_DI)
 - Database Replication Detail (PD_RD)
 - Database Space Detail (PD_DS)
 - Global Server Summary (PI)
 - Global Server Summary 2 (PI_PI2)
 - Licensing Detail (PD_LIC)
 - Lock Detail (PD_LD)
 - Process Detail (PD_PDET)
 - Server Detail (PD)
 - Server Locks Detail (PD_LOCK)
 - Server Overview (PI_SERV)

- Server Overview 2 (PI_SRV2)
- Server Space Detail (PD_SS)
- Server Space Interval (PI_SI)
- SQL Text (PD_SQL)
- User-Defined Counter Overview (PI_UCTR)
- User Process Detail (PD_USER)
- Fields were added to the following records. The figure to show the relationship among the added fields and existing fields was also added:
 - Database Space Detail (PD_DS)
- Fields were added to the following records:
 - Job History Detail (PD_JH)
- The following messages have been added.
 - KAVF21851-I
- The following messages have been changed:
 - KAVF21810-E, KAVF21812-E
- The following records now have a separate description about how to calculate the number of instances in SQL Server 2014 or earlier and SQL Server 2016 or later:
 - Database Interval (PI_DI)
 - Database Detail (PD_DD)
 - Database Space Detail (PD_DS)
 - Lock Detail (PD_LD)
 - Process Detail (PD_PDET)
 - Database Replication Detail (PD_RD)
 - User Process Detail (PD_USER)

M.3 Revisions in 11-00

- Windows Server 2003 was deleted from the OSs on which PFM - Agent for Microsoft SQL Server runs.
- The default value of `LIMIT_PD_LD_NUMBER`, which is a monitoring item of PFM - Agent for Microsoft SQL Server, was changed.
- The following languages can now be used with Performance Management:
 - Chinese (Simplified characters)
 - Korean
 - Spanish
 - German
 - French
 - Russian
- Monitoring Console Https is now included as one of the Agent Collector service properties.

- The product name was changed from PFM - Agent for OpenTP1 to PFM - Agent for Transaction System.
- The product name was changed from JP1/ITSLM to JP1/SLM.

M.4 Revisions in 10-00

- The following has been added as databases that can be monitored:
 - Microsoft SQL Server 2012
 - Microsoft SQL Server 2014
- LIMIT_PD_LD_NUMBER has been added to the instance information.
- LIMIT_PD_EE_NUMBER has been added to the instance information.
- Information about monitoring items for monitoring services through linkage with JP1/IT Service Level Management has been added. Also, a description of the following monitoring items has been added:
 - Cache Hit rate
 - CPU usage rate
 - Database free space rate
 - Log space usage rate
- Performance data can be collected in an IPv6 environment.
- The following messages have been added:
 - KAVF19848-W
 - KAVF19849-W

M.5 Revisions in 09-00

- The name solution set has changed to monitoring template.
- The following reports have been added:
 - Log I/O Activity 2
 - Physical Write Activity 2
- The following records have been added:
 - Global Server Summary 2 (PI_PI2)
 - Server Overview 2 (PI_SRV2)

With the addition of new-format commands compatible with 08-51 or earlier commands, the commands for 09-00 or later is now indicated as follows:

command-for-09-00-or-later (command-for-08-51-or-earlier)

- The setup command was changed so that it can be executed in non-interactive mode.

N. Reference Material for This Manual

This appendix provides reference information, including various conventions, for this manual.

N.1 Related publications

This manual is part of a related set of manuals. The manuals in the set are listed below (with the manual numbers):

Manuals associated with JP1/Performance Management:

- *JP1 Version 11 Performance Management: Getting Started (Operation and Performance Management)* (3021-3-A36(E))
- *JP1/Performance Management Planning and Configuration Guide* (3021-3-A37(E))
- *JP1/Performance Management User's Guide* (3021-3-A38(E))
- *JP1/Performance Management Reference* (3021-3-A39(E))

Manuals associated with JP1:

- *Job Management Partner 1/Software Distribution Administrator's Guide Volume 1* (3020-3-S81(E)), for Windows systems
- *Job Management Partner 1/Software Distribution Manager Description and Administrator's Guide* (3000-3-841(E))
- *Job Management Partner 1/Software Distribution SubManager Description and Administrator's Guide* (3020-3-L42(E)), for UNIX systems
- *Job Management Partner 1/Software Distribution Client Description and User's Guide* (3020-3-S85(E)), for UNIX systems

N.2 Conventions: Abbreviations for product names

This manual uses the following abbreviations for product names:

Abbreviation		Full name or meaning
AIX		AIX V6.1
		AIX V7.1
		AIX V7.2
HP-UX	HP-UX 11i	HP-UX 11i V3 (IPF)
IPF		Itanium(R) Processor Family
JP1/IM	JP1/IM - Manager	JP1/Integrated Management - Manager
	JP1/IM - View	JP1/Integrated Management - View
JP1/ITSLM (10-50 and earlier)	JP1/ITSLM - Manager	JP1/IT Service Level Management - Manager
	JP1/ITSLM - UR	JP1/IT Service Level Management - User Response
JP1/SLM	JP1/SLM - Manager	JP1/Service Level Management - Manager
	JP1/SLM - UR	JP1/Service Level Management - User Response

Abbreviation			Full name or meaning
JP1/NETM/DM			JP1/NETM/DM Client
			JP1/NETM/DM Manager
			JP1/NETM/DM SubManager
Linux	CentOS	CentOS 6 (x64)	CentOS 6.1 (x64) or later
		CentOS 7	CentOS 7.1 or later
	Linux 6 (x64)		Red Hat Enterprise Linux(R) Server 6.1 (64-bit x86_64) or later
	Linux 7		Red Hat Enterprise Linux(R) Server 7.1 or later
	Oracle Linux	Oracle Linux 6 (x64)	Oracle Linux(R) Operating System 6.1 (x64) or later
		Oracle Linux 7	Oracle Linux(R) Operating System 7.1 or later
	SUSE Linux	SUSE Linux 12	SUSE Linux(R) Enterprise Server 12
Performance Management			JP1/Performance Management
PFM - Agent	PFM - Agent for Cosminexus [#]		JP1/Performance Management - Agent Option for uCosminexus Application Server
	PFM - Agent for DB2		JP1/Performance Management - Agent Option for IBM DB2
	PFM - Agent for Domino		JP1/Performance Management - Agent Option for IBM Lotus Domino
	PFM - Agent for Enterprise Applications		JP1/Performance Management - Agent Option for Enterprise Applications
	PFM - Agent for Exchange Server [#]		JP1/Performance Management - Agent Option for Microsoft(R) Exchange Server
	PFM - Agent for HiRDB [#]		JP1/Performance Management - Agent Option for HiRDB
	PFM - Agent for IIS [#]		JP1/Performance Management - Agent Option for Microsoft(R) Internet Information Server
	PFM - Agent for JP1/AJS [#]	PFM - Agent for JP1/AJS2	JP1/Performance Management - Agent Option for JP1/AJS2
		PFM - Agent for JP1/AJS3	JP1/Performance Management - Agent Option for JP1/AJS3
	PFM - Agent for Microsoft SQL Server		JP1/Performance Management - Agent Option for Microsoft(R) SQL Server
	PFM - Agent for Oracle		JP1/Performance Management - Agent Option for Oracle
	PFM - Agent for Platform	PFM - Agent for Platform(UNIX)	JP1/Performance Management - Agent Option for Platform(UNIX)
		PFM - Agent for Platform(Windows)	JP1/Performance Management - Agent Option for Platform(Windows)
	PFM - Agent for Service Response		JP1/Performance Management - Agent Option for Service Response
PFM - Agent for Transaction System [#]		JP1/Performance Management - Agent Option for Transaction System	

Abbreviation		Full name or meaning	
PFM - Agent	PFM - Agent for WebLogic Server [#]	JP1/Performance Management - Agent Option for BEA WebLogic Server	
		JP1/Performance Management - Agent Option for Oracle(R) WebLogic Server	
	PFM - Agent for WebSphere Application Server [#]	JP1/Performance Management - Agent Option for IBM WebSphere Application Server	
	PFM - Agent for WebSphere MQ [#]	JP1/Performance Management - Agent Option for IBM WebSphere MQ	
PFM - Base		JP1/Performance Management - Base	
PFM - Manager		JP1/Performance Management - Manager	
PFM - RM	PFM - RM for Microsoft SQL Server		JP1/Performance Management - Remote Monitor for Microsoft(R) SQL Server
	PFM - RM for Oracle		JP1/Performance Management - Remote Monitor for Oracle
	PFM - RM for Platform	PFM - RM for Platform(UNIX)	JP1/Performance Management - Remote Monitor for Platform(UNIX)
		PFM - RM for Platform(Windows)	JP1/Performance Management - Remote Monitor for Platform(Windows)
	PFM - RM for Virtual Machine		JP1/Performance Management - Remote Monitor for Virtual Machine
PFM - Web Console		JP1/Performance Management - Web Console	
Solaris	Solaris 10	Solaris 10 (SPARC)	
	Solaris 11	Solaris 11 (SPARC)	

- PFM - Manager, PFM - Agent, PFM - Base, PFM - Web Console, and PFM - RM may be referred to collectively as *Performance Management*.
- HP-UX, Solaris, AIX, and Linux may be referred to collectively as *UNIX*.

#

This product only runs in a Japanese environment.

N.3 Conventions: Acronyms

This manual also uses the following acronyms:

Acronym	Full name or meaning
API	Application Programming Interface
DHCP	Dynamic Host Configuration Protocol
DNS	Domain Name System
FQDN	Fully Qualified Domain Name
GUI	Graphical User Interface
HA	High Availability
HTML	HyperText Markup Language
HTTP	HyperText Transfer Protocol

Acronym	Full name or meaning
IPv4	Internet Protocol Version 4
IPv6	Internet Protocol Version 6
LAN	Local Area Network
NAPT	Network Address Port Translation
NAT	Network Address Translation
MFC	Microsoft Foundation Class
ODBC	Open DataBase Connectivity
OS	Operating System
SP	Service Pack
UAC	User Account Control
WRP	Windows Resource Protection

N.4 Conventions: Product names, service IDs, and service keys

Performance Management version 09-00 or later can display the product name as the service ID and service key by enabling the product name display functionality.

Identifiers	Product name display functionality	
	Disabled	Enabled
Service ID	QS1 hostname	hostname <SQL>(Store)
	QA1 hostname	hostname <SQL>
Service Key	agtq	SQL

Hereafter in this manual, service IDs and service keys are shown in the format when the product name display functionality is enabled.

Note that you can enable the product name display functionality only when you satisfy the two conditions listed below:

- The version number of the prerequisite programs (PFM - Manager or PFM - Base) is 09-00 or later.
- The version number of PFM - Web Console and connection-target PFM - Manager is 09-00 or later.

N.5 Conventions: Installation folder

In this manual, the installation folder for the Windows version of Performance Management is indicated by *installation-folder*. The installation directory for the UNIX version of Performance Management is indicated by *installation-directory*.

The default installation folder for the Windows version of Performance Management is as follows.

Installation-folder for PFM - Base:

```
system-drive\Program Files(x86)\Hitachi\jplpc
```

This manual uses the term *installation folder* for the PFM - Base installation folder.

Installation-folder for PFM - Management:

`system-drive\Program Files (x86)\Hitachi\jplpc`

Installation-folder for PFM - Web Console:

`system-drive\Program Files (x86)\Hitachi\jplpcWebCon`

The default installation directory for the UNIX version of Performance Management is as follows:

Installation-directory for PFM - Base:

`/opt/jplpc`

Installation-directory for PFM - Manager:

`/opt/jplpc`

Installation-directory for PFM - Web Console:

`/opt/jplpcwebcon`

N.6 Conventions: KB, MB, GB, and TB

This manual uses the following conventions:

- 1 KB (kilobyte) is 1,024 bytes.
- 1 MB (megabyte) is 1,024² bytes.
- 1 GB (gigabyte) is 1,024³ bytes.
- 1 TB (terabyte) is 1,024⁴ bytes.

O. Glossary

action

An action executed automatically by Performance Management when the data being monitored reaches a threshold value. The following actions are supported:

- Sending an email
- Executing a command
- Issuing an SNMP trap
- Issuing a JP1 event

Action Handler

A PFM - Manager or PFM - Base service that executes actions.

alarm

Information that defines an action or event message that is triggered when the data being monitored reaches a threshold value.

alarm table

A table containing the following definition information about one or more alarms:

- Monitored object (process, TCP, Web service, and so on)
- Monitored information (CPU usage, number of bytes received per second, and so on) Monitored condition (threshold value)

Agent

The PFM - Agent service that collects performance data.

Agent Collector

One of the PFM - Agent services. It is a service for collecting performance data and evaluating performance data based on a threshold value that is set in an alarm.

Agent Store

One of the PFM - Agent services. It is a service for storing performance data. The Agent Store service uses a database for recording performance data. Each PFM - Agent has its own Agent Store service.

binding

The process of associating alarms with an agent. Binding enables the user to be notified when the performance data collected by the agent reaches a threshold value defined in an alarm.

cluster system

A single system configured from multiple linked server systems. There are two major types of cluster systems: an HA (High Availability) cluster system and a load-balancing cluster system.

In this manual, a *cluster system* means an HA cluster system.

→ *HA cluster system*

→ *Load-balancing cluster system*

Correlator

A PFM - Manager service that controls event distribution between services. This service evaluates the alarm status, and sends an alarm event or agent event to the Trap Generator service and to PFM - Web Console if the alarm status exceeds a threshold value.

database ID

An ID attached to each record in PFM - Agent, indicating the database in which the record is stored and the record type. The database ID may be either of the following:

- PI
Indicates that the database contains records of the PI record type.
- PD
Indicates that the database contains records of the PD record type.

data model

A generic term for the records and fields contained in a PFM - Agent. Data models are versioned.

drilldown report

A report related to another report or to the fields in the report. A drilldown report can be used to display detailed information or related information for a report.

executing node

Of the server systems in a cluster system, the node that is currently executing applications (node whose logical host is active).

failover

The process by which the standby node takes over processing if a failure occurs on the node that is executing applications in a cluster system.

field

Individual operation information entries in a record. Each field serves as a monitoring item for Performance Management.

Function ID

A one-byte identifier indicating the function type of a service of Performance Management programs. This is part of the service ID.

HA cluster system

A cluster system designed to implement high availability by continuing operation even if one system fails. If a failure occurs on the server currently executing applications, a separate standby server takes over and continues the processing of applications. Accordingly, because application processing is not interrupted when a failure occurs, availability improves.

In this manual, a *cluster system* means an HA cluster system.

historical report

A report that tracks the status of an object being monitored from a point in the past to the present.

instance

In this manual, the term *instance* is used as follows.

- To indicate the format of a record:
A record written on one line is known as a *single-instance record*. A record spanning multiple lines is known as a *multi-instance record*, each line of which is known as an *instance*.
- To indicate the number of PFM - Agent:
A single agent that monitors all the target objects on a host is known as a *single-instance agent*. Agents that share the monitoring of target objects on a host are known collectively as a *multi-instance agent*. Each of these agent services of a multi-instance agent is called an *instance*.

instance number

An identifier for management number used for internal processing. An instance number is part of the service ID.

JP1/SLM

A product that performs monitoring from the viewpoint of performance as experienced by the service users of a business system, and that supports service-level maintenance. Linkage with JP1/SLM can enhance monitoring of the operating status.

lifetime

The length of time that the consistency of the performance data collected in each record is retained.

load-balancing cluster system

A system that distributes the processing load over multiple nodes to improve throughput. Because processing switches to another node if an executing node stops due to a failure, this system also improves the availability of the system.

logical host

A logical server that provides the JP1 execution environment for operation in a cluster system. If a failure occurs on the executing node, the logical host is switched to the standby node. Each logical host has a unique IP address. At failover, the IP address is inherited by the standby node. Thus, when the physical server is failed over, clients can still access the logical host using the same IP address. To the clients, it appears that one server is operating continuously.

management tool

Any command or GUI-based function used to verify the status of a service or to manipulate performance data. Management tools allow you to:

- Display the configuration and status of a service
- Save and restore performance data
- Export performance data to a text file
- Delete performance data

Master Manager

A PFM - Manager service. This is the main service of PFM - Manager.

Master Store

A PFM - Manager service that manages the alarm events issued from each PFM - Agent. This service uses a database to store the event data.

monitoring template

A set of predefined alarms and reports provided by PFM - Agent. The monitoring template facilitates preparation for monitoring of the PFM - Agent operation status without the user having to enter complex definitions.

multi-instance record

A record spanning multiple lines. This type of record has unique ODBC key fields.

→ *instance*

Non-interactive (command)

Command execution method in which operator input required for command execution are provided by values in option specifications or in definition files.

Executing a command non-interactively saves work when configuring an operation monitoring system and can reduce user workload.

ODBC key field

These fields display the primary keys that are necessary to use the data retrieved from records stored in the Store database on either PFM - Manager or PFM - Base. Some ODBC key fields are common to all records; others are record-specific.

PD record type

→ *Product Detail record type*

performance data

Data about the operation status of a resource, collected from the system being monitored.

Performance Management

A generic term for a family of software products used to monitor and analyze problems related to system performance. Performance Management consists of the following five program products:

- PFM - Manager
- PFM - Web Console
- PFM - Base
- PFM - Agent
- PFM - RM

PFM - Agent

One of the program products in the Performance Management family. PFM - Agent is responsible for system monitoring. Several types of PFM - Agent are available, depending on the applications, database, and OS to be monitored. PFM - Agent provides the following features:

- Performance monitoring of target objects
- Collection and recording of data from monitored objects

PFM - Base

One of the program products in the Performance Management family. PFM - Base provides the core functionality for operation monitoring in Performance Management. It is a prerequisite product for running PFM - Agent and provides the following features:

- Commands and other management tools
- Common functions for linking Performance Management with another system

PFM - Manager

One of the program products in the Performance Management family. PFM - Manager performs supervisory functions and provides the following features:

- Management of the Performance Management program products
- Event management

PFM - Manager name

A field name that identifies the field in the Store database that stores the reference data. Use this name, for example, when you execute any command with the field name in the Store database.

PFM - View name

Alias name for PFM - Manager name. PFM - View name is more intuitive than PFM - Manager name. For example, "INPUT_RECORD_TYPE" (PFM - Manager name) is "Record Type" (PFM - View name). Use this field name, for example, when you specify the field name in the PFM - Web Console windows.

PFM - Web Console

One of the program products in the Performance Management family. PFM - Web Console operates as a Web application server to enable centralized monitoring of the Performance Management system via a web browser. It provides the following features:

- Display in a graphical user interface
- Integrated monitoring and management
- Definition of reports and alarms

physical host

An environment unique to each server in a cluster system. When a failover occurs, the environment of the physical host is not inherited by the other server.

PI record type

→ *Product Interval record type*

process

A unit that represents a specific user connection in Microsoft SQL Server. Every process has a unique identifier named *SQL Server Process ID (SPID)*. A new identifier is assigned whenever a user connection is established.

A *process* in this context defers from a so-called process, which is created when a Windows application program runs.

Product Detail record type

A type of record for storing performance data indicating the system status at a specific point in time, such as detail information about the currently running process. PD records can be used to acquire system statuses such as the following at a specific point in time:

- System operation status
- Amount of file system capacity currently in use

product ID

A one-byte ID indicating the Performance Management program product to which the service of the Performance Management program belongs. A product ID is part of the service ID.

Product Interval record type

A type of record for storing performance data at set intervals, such as a process count every minute. PI records can be used to analyze such time-based changes and trends in the system status such as the following:

- Number of system calls generated within a set time period
- Changes in the amount of file system capacity used

real-time report

A report that shows the current status of an object being monitored.

record

A group of operation information entries categorized by their purpose. A monitoring agent collects operation information from each record. The types of records that can be collected vary depending on the agent program.

report

Information defined for graphical display of the performance data collected by PFM - Agent. The main types of information you can define are as follows:

- The records to be displayed in a report
- The performance data items to be displayed
- The display format of performance data (table, graph, and so on)

service ID

A unique ID assigned to each service of the Performance Management programs. You must specify the service ID when you execute a command to check the Performance Management system configuration or to back up performance data of an agent, for example. The format of the service ID differs depending on the setting of the product name display functionality. For details about the format of the service ID, see the

chapter on Performance Management functionalities in the *JP1/Performance Management Planning and Configuration Guide*.

single-instance record

A record written on a single line. This type of record does not have any unique ODBC key fields.

→ *instance*

stand-alone mode

A PFM - Agent activated as a stand-alone program. If either of the PFM - Manager services Master Manager or Name Server is disabled due to a failure or another problem, you can still collect performance data by starting PFM - Agent.

standby node

Of the server systems in a cluster system, a node that is waiting to take over applications if the executing node fails.

Store database

A database containing performance data collected by the Agent Collector service.

Index

A

A4QHITACHIPROCSPDATABASES Stored Procedure
 setup (in cluster system) 96
abbreviations for products 347
About service dependencies 110
acronyms 349
action 19, 352
Action Handler 352
Agent Collector 352
Agent Collector service
 properties 316
Agent log 292, 294
Agent Store 352
Agent Store service
 properties 313
alarm 20, 352
Alarm
 Blocked Sessions 117
 Cache Usage 118
 CPU Usage 119
 Database Space 120
 Log Space Usage 121
 Network Error 122
 Server Status 123
alarm table 20, 352

B

Backup 76
Backup and restoration 76
Before editing the jpcsto.ini file 64
binding 20, 352

C

Calculating the number of instances for records 306
Canceling setup of an instance environment 59
Cancel setup of the logical host environments for other Performance Management programs 104
Cancel setup of the logical host environments for PFM - Agent for Microsoft SQL Server 103
Change the size of log files 97
Changing the operation of PFM - Agent for Microsoft SQL Server 62
Changing the size of log files 55

Changing the storage location of performance data 56, 62
Changing the system configuration of PFM - Agent for Microsoft SQL Server 61, 107
Clear the port number settings 103
cluster software
 setting up environment (Windows) 100
cluster system 352
 Disk space requirements 306
 installation and setup 33
 overview 81
Collecting troubleshooting information 300
Common message log 291, 293
conventions
 diagrams 8
 fonts and symbols 8
 mathematical expressions 10
 version numbers 10
Correlator 353
CPU usage ratio per session 24

D

database ID 353
data model 19, 353
Data model 171
DB_FREE_PERC_NUMBER 42
DB_FREE_PERC_OPTION 42
Delete an instance environment 59
Delete settings from PFM - Manager 106
Detecting errors in Performance Management 303
determining baseline 23
diagram conventions 8
Disk space requirements 306
drilldown report 353
Drilldown reports (field level) 124
Drilldown reports (report level) 124

E

Editing the jpcsto.ini file 64
Effects when PFM - Manager stops 87
Error Handling Procedures 287
Estimating System Requirements 306
example of performance monitoring using PFM - Agent for Microsoft SQL Server 23
executing node 353

F

- failover 353
 - processing during 85
- Failover in the mirroring configuration 71
- Failover when a failure occurs on a PFM - Agent host 85
- features of PFM - Agent for Microsoft SQL Server 18
- Federated database server 83
- field 19, 124, 353
- Fields added only when data is stored in the Store database 181
- Fields output when data stored in the Store database is exported 182
- Flow for installation and setup 88
- font conventions 8
- Format of alarm explanations 114
- Format of message explanation 259
- Format of output messages 258
- Format of report explanations 124
- function ID 353

G

- GB meaning 351

H

- HA cluster system 81, 353
- historical report 18, 354
- Host name in the collected performance data 110

I

- increase in the number of locks 25
- installation 27, 28
 - in cluster system 33
 - methods 36
 - notes on installing multiple Performance Management programs on one host 34
 - order 36
 - preparation 29
 - procedure 36
 - workflow 28
- installation
 - notes on environmental variable 34
- installation (in cluster system)
 - preparation (Windows) 90
 - Windows 88
- installation folder conventions 350
- Installation procedure 94

- instance 354
- instance environment
 - setting (in cluster system) (Windows) 96
 - setting up 40
- instance number 354
- instance validity 26
- insufficient database space 25
- insufficient data cache 24
- insufficient log space 24
- IP address settings 29

J

- JP1/SLM 354
- jpccconf agent setup command 38
- jpccconf inst list command 59, 67
- jpccconf inst setup command 67
- jpccconf inst unsetup command 59
- jpccctrl delete command 60
- jpccctrl list command 58
- jpchosts file 97
- jpcnshostname command 56
- jpcras command 300

K

- KB meaning 351

L

- lifetime 354
- LIMIT_PD_EE_NUMBER 42
- LIMIT_PD_LD_NUMBER 42
- List of alarms 116
- List of Files and Folders 324
- List of Identifiers 310
- List of log files and directories 293
- List of ODBC key fields 175
- List of Port Numbers 312
- List of Processes 311
- List of reports 127
- load-balancing cluster system 354
- LOG_PATH 41
- LOG_SIZE 41
- logical host 354
- logical-host environment definition file
 - copying to standby node (Windows) 98, 105
 - export and import 109
- LOGIN_TIMEOUT 41

Log information 291
Log output for a cluster system 110

M

management tool 354
Master Manager 355
Master Store 355
mathematical expressions
 conventions 10
MB meaning 351
Memory requirements 306
Message format 258
Message List 265
Message output destinations 260
Messages 257
Messages output to the Windows event log 264
Microsoft SQL Server instance name 40
migration
 notes on 327
 procedure 327
Monitoring after a failover occurs in databases in the mirroring configuration 73
Monitoring after failover in the SQL Server AlwaysOn Availability Group configuration 75
Monitoring databases in the mirroring configuration 71
Monitoring during failover in the SQL Server AlwaysOn Availability Group configuration 74
Monitoring in the SQL Server AlwaysOn Availability Group configuration 74
monitoring template 20, 113, 355
Monitoring Template 112
Monitoring while a failover occurs in databases in the mirroring configuration 72
multi-instance record 355

N

network environment settings 29
network load 26
network settings, specifying
 in cluster system (Windows) 97
Note on network configuration 58
Note on OS user permission required to uninstall PFM - Agent 58
Notes of alarms 115
Notes on operating PFM - Agent for Microsoft SQL Server in a cluster system 110
Notes on programs 58
Notes on services 58

O

ODBC key field 355
Online manuals 78
Operating PFM - Agent for Microsoft SQL Server in a Cluster System 80
Operation status log 291
Organization of report folders 125
OS requirements 29
other cautionary notes 35
Outputting Action Log Information 332
Outputting the action logs 57
overview
 monitoring template 113
overview of PFM - Agent for Microsoft SQL Server 17

P

PD 227
PD_CD 187
PD_DD 189
PD_DS 197
PD_EE 200
PD_ES 202
PD_IA 210
PD_JH 212
PD_LD 215
PD_LIC 214
PD_LOCK 233
PD_PCAC 218
PD_PDET 220
PD_RD 195
PD_RS 225
PD_SQL 248
PD_SS 244
PD_USER 254
PD record type 355
performance data 355
 collection procedure 22
 management procedure 22
 overview of collecting and managing 22
Performance Management 355
Performance Management programs 33
permission for installing PFM - Agent for Microsoft SQL Server 31
PFM - Agent 356
PFM - Agent for Microsoft SQL Server
 example of performance monitoring 23

- features [18](#)
- overview [17](#)
- registering [37](#)
- PFM - Agent for Microsoft SQL Server files and directories [324](#)
- PFM - Base [356](#)
- PFM - Manager [356](#)
 - setting as connection target (in cluster system) (Windows) [96](#)
- PFM - Manager name [356](#)
- PFM - View name [356](#)
- PFM - Web Console [356](#)
- physical host [356](#)
- PI [204](#)
- PI_DI [193](#)
- PI_PI2 [207](#)
- PI_RPDB [223](#)
- PI_SERV [236](#)
- PI_SI [246](#)
- PI_SRV2 [240](#)
- PI_TLOG [250](#)
- PI_UCTR [252](#)
- PI record type [356](#)
- port number settings [31](#)
- Port numbers for PFM - Agent for Microsoft SQL Server [312](#)
- prerequisite programs [31](#)
- Procedure for deleting A4QHITACHIPROCSPDATABASES [330](#)
- process [357](#)
- Product Detail record type [357](#)
- product ID [357](#)
- Product Interval record type [357](#)
- product names conventions [350](#)
- programs that can be monitored [32](#)
- properties [313](#)
 - Agent Collector service [316](#)
 - Agent Store service [313](#)

R

- real-time report [18, 357](#)
- record [19, 124, 170, 357](#)
 - Config Detail (PD_CD) [187](#)
 - Database Detail (PD_DD) [189](#)
 - Database Interval (PI_DI) [193](#)
 - Database Replication Detail (PD_RD) [195](#)
 - Database Space Detail (PD_DS) [197](#)

- Errorlog Error Detail (PD_EE) [200](#)
- Errorlog Summary Detail (PD_ES) [202](#)
- explanation format [172](#)
- Field values [179](#)
- Global Server Summary (PI) [204](#)
- Global Server Summary 2 (PI_PI2) [207](#)
- Instance Availability (PD_IA) [210](#)
- Job History Detail (PD_JH) [212](#)
- Licensing Detail (PD_LIC) [214](#)
- List [185](#)
- List of data types [178](#)
- Lock Detail (PD_LD) [215](#)
- Notes [183](#)
- Procedure Cache Detail (PD_PCAC) [218](#)
- Process Detail (PD_PDET) [220](#)
- Replication Published Database Overview (PI_RPDB) [223](#)
- Replication Summary Detail (PD_RS) [225](#)
- Server Detail (PD) [227](#)
- Server Locks Detail (PD_LOCK) [233](#)
- Server Overview (PI_SERV) [236](#)
- Server Overview 2 (PI_SRV2) [240](#)
- Server Space Detail (PD_SS) [244](#)
- Server Space Interval (PI_SI) [246](#)
- SQL Text (PD_SQL) [248](#)
- Summary rules [176](#)
- Transaction Log Overview (PI_TLOG) [250](#)
- User-Defined Counter Overview (PI_UCTR) [252](#)
- User Process Detail (PD_USER) [254](#)
- record type
 - PD record type [19](#)
 - PI record type [19](#)
 - Product Detail record type [19](#)
 - Product Interval record type [19](#)
- Recovering from errors in Performance Management system [304](#)
- registering PFM - Agent for Microsoft SQL Server [37](#)
- Registering the A4QHITACHIPROCSPDATABASES Stored Procedure [54](#)
- Register PFM - Agent for Microsoft SQL Server [95](#)
 - report [18, 357](#)
 - Cache Usage Trend(Multi-Agent) [133](#)
- Report
 - Blocked Sessions [129](#)
 - Blocking Locks [131](#)
 - Cache Usage [132](#)
 - Cache Usage Trend(Multi-Agent) [134](#)

- CPU Usage - Top 10 Sessions 135
- Database Detail 136
- Database Space Usage 138
- Database Space Usage Detail 139
- Database Summary 140
- Errorlog Detail 142
- Errorlog Overview 143
- Lock Detail 144
- Lock Overview 145
- Lock Overview by Lock Type 146
- Lock Usage - Top 10 Sessions 147
- Log I/O Activity 148
- Log I/O Activity 2 149
- Log Space Usage - Top 10 Databases 150
- Memory Usage - Top 10 Sessions 151
- Network Activity 152
- Network Activity Trend 153, 154
- Pending I/O 155
- Physical I/O - Top 10 Sessions 156
- Physical Write Activity 157
- Physical Write Activity 2 158
- Server Configuration Status 159
- Server CPU Trend 160, 161
- Server Space Trend(Multi-Agent) 162, 163
- Server Space Usage 164
- Session Detail 165
- Sessions 167
- System Overview 168
- Required troubleshooting information 296
- Restoration 77
- Routing through a firewall 312

S

- service ID 357
- service ids conventions 350
- service keys conventions 350
- Setting items in jpcsto.ini 63
- Setting the connection-target PFM - Manager of PFM - Agent for Microsoft SQL Server 56
- setting up
 - instance environment 40
- Setting up an instance environment 40
- Setting up the action log 97
- setup 27, 28
 - canceling 58
 - copying setup files 39

- executing setup command on PFM - Manager host 39
- executing setup command on PFM - Web Console host 40
- in cluster system 33
- notes on setting up multiple Performance Management programs on one host 34
- preparation 29
- procedure 37
- procedure for canceling 59
- workflow 28
- setup (in cluster system)
 - Changing the operation of PFM - Agent for Microsoft SQL Server 108
 - checking whether services can be started and stopped from cluster software (Windows) 100
 - exporting logical-host environment definition file (Windows) 98
 - importing logical-host environment definition file (Windows) 98
 - preparation (Windows) 90
 - registering PFM - Agent in cluster software (Windows) 99
 - Windows 88
- setup cancellation
 - cautionary notes 58
- setup cancellation (in cluster system)
 - exporting logical-host environment definition file (Windows) 104
 - importing logical-host environment definition file (Windows) 105
 - unregistering PFM - Agent from cluster software (Windows) 105
 - workflow (Windows) 101
- setup cancellation (Windows) 101
- Setup cancellation procedure 102
- setup command
 - PFM - Manager host 39
 - PFM - Web Console host 40
- Setup procedure 94
- Set up the logical host environment for other Performance Management programs 97
- Set up the logical host environment for PFM - Agent for Microsoft SQL Server 95
- shared disk
 - bringing online 95, 103
 - taking offline 98, 105
- single-instance record 358
- Specifying network settings 55

- SQL_ERRORLOG 41
- SQL_HOST 40
- SQL_PASSWORD 41
- SQL_USER 40
- stand-alone mode 358
- standby node 358
- Starting the command prompt 70
- STARTUP_PENDING 41
- Stop services from the cluster software 103
- storage location of performance data
 - setup (in cluster system) 97
- Store database 19, 358
- stored procedure
 - R4QHITACHIPROCSPDATABASES, deleting 330
- Store Version 41
- symbol conventions 8
- syntax conventions 9
- System log 291

T

- TB meaning 351
- the status management facility 303
- TIMEOUT 41
- Timeout 111
- Trace log 292, 294
- Troubleshooting procedures 289

U

- uninstallation 58
 - cautionary notes 58
 - Procedure for uninstallation 60
- uninstallation (in cluster system)
 - Windows 101
 - workflow (Windows) 101
- Uninstallation procedure 106
- update
 - instance environment 108
- Updating an instance environment 65
- Updating the Store version to 2.0 67
- upgrading PFM - Agent for Microsoft SQL Server
 - notes 35

V

- Version Compatibility 329
- version number conventions 10

 **Hitachi, Ltd.**

6-6, Marunouchi 1-chome, Chiyoda-ku, Tokyo, 100-8280 Japan
